



GLOBAL
FIRE EQUIPMENT

J-NET-INT-RS485

Data Loop

RS-485 Interface

DATA SHEET
&
INSTALLATION
MANUAL

The J-NET-INT-RS485 interface module allows GFE's range of panels to be interfaced to repeaters and/or sub-panels using a 4-core data communication cable suitable for RS-422/RS-485 data transmission using a common data communication loop in a ring topology. These units can also use a double-redundant data communication loop for extra security and reliability when used in conjunction with a Juno Net or Junior main panel by creating a bi-directional communication flow. In this case if the Juno Net or Junior panel is unable to communicate with a repeater or sub-panel due to a cable cut or short circuit, it will try to establish communication via the 2nd loop. A communication fault will be signalled by the Juno Net main panel when communication is lost with any sub-panels or repeater panel equipped with a loop card. Please note that Junior panels can only be interfaced with Mini-Repeaters.

This interface is used in the fire alarm control panel to provide a communications interface for the following:

- 1) An Orion conventional panel and its repeater(s).
- 2) A Junior, analogue addressable panel, and its mini-repeater(s).
- 3) A Juno Net panel and Juno Net Repeater(s), Mini-Repeater(s) and or Sub-Panels.

This interface is compatible with the following panels, repeaters and sub-panels:

- 1) Orion Conventional Panel 2, 4 and 8 zones.
- 2) Orion Repeater.
- 3) Junior, 1 loop analogue addressable panel, non-expandable.
- 4) Mini-Repeater.
- 5) Juno Net, expandable analogue addressable panel.
- 6) Juno Net Repeater
- 7) Sub-Panel.

This interface can be used in parallel with other similar modules using other interface technologies such as RS-232, Fibre Optics and TCP/IP, providing the installer with the tools to interface and create a network of panels, repeaters and sub-panels using mixed data communication technologies, catering for the most demanding applications and networking requirements.

Each panel, repeater and sub-panel will require one of these interface modules. The maximum distance between two nodes is 1.2Kms including the return path to the main panel.

Custom made versions of these modules can be produced for connection to GFE's proprietary MPX protocol to connect leds, mimic displays, relays and conventional sounder circuits to GFE's extensive range of conventional and analogue addressable panels. Please consult GFE for further information.

Supply Voltage	18-29 V DC (28 V DC nominal)
Current Consumption	14 mA
Hardware compatibility	Juno Net, Junior, Juno Net Repeater, Mini-Repeater and Sub-Panels all board versions. Orion version 1.4 and above.
Software compatibility	Juno Net, Junior, Juno Net Repeater, Mini-Repeater and Sub-Panels all software versions. Orion version 1.4 and above.
Maximum cable length	1.2 Kms between any 2 nodes including return path to main panel.
P.C.B. Dimensions	135.0 x 35.5 mm
Weight	47 grams

Warning: Disconnect all power sources including primary (electrical mains) and secondary (batteries) supplies, before connecting or disconnecting these interface modules and/or any other internal circuit boards.

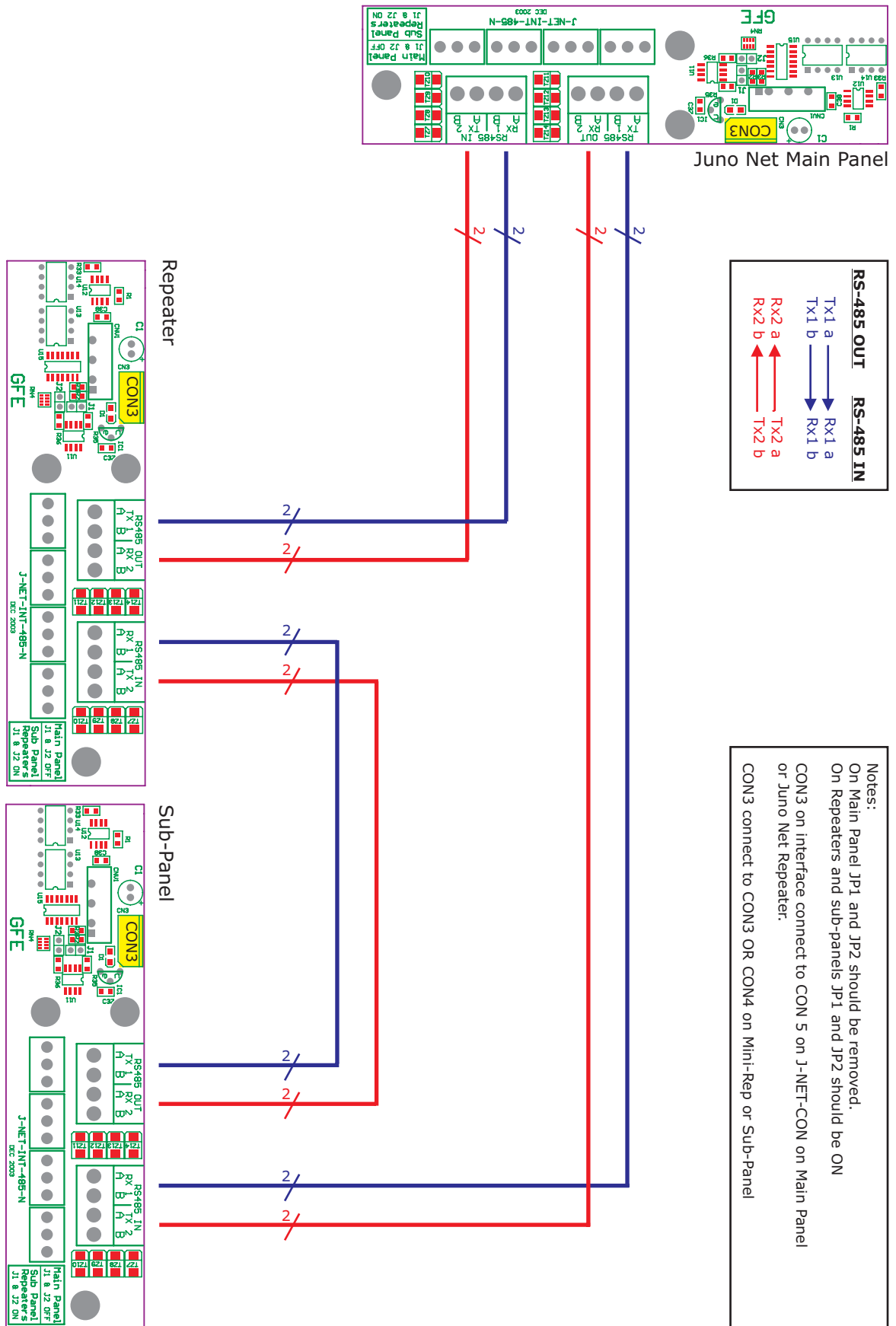

Figure 1 Juno Net Panel - Repeater - Sub-Panel - Data Loop Conections

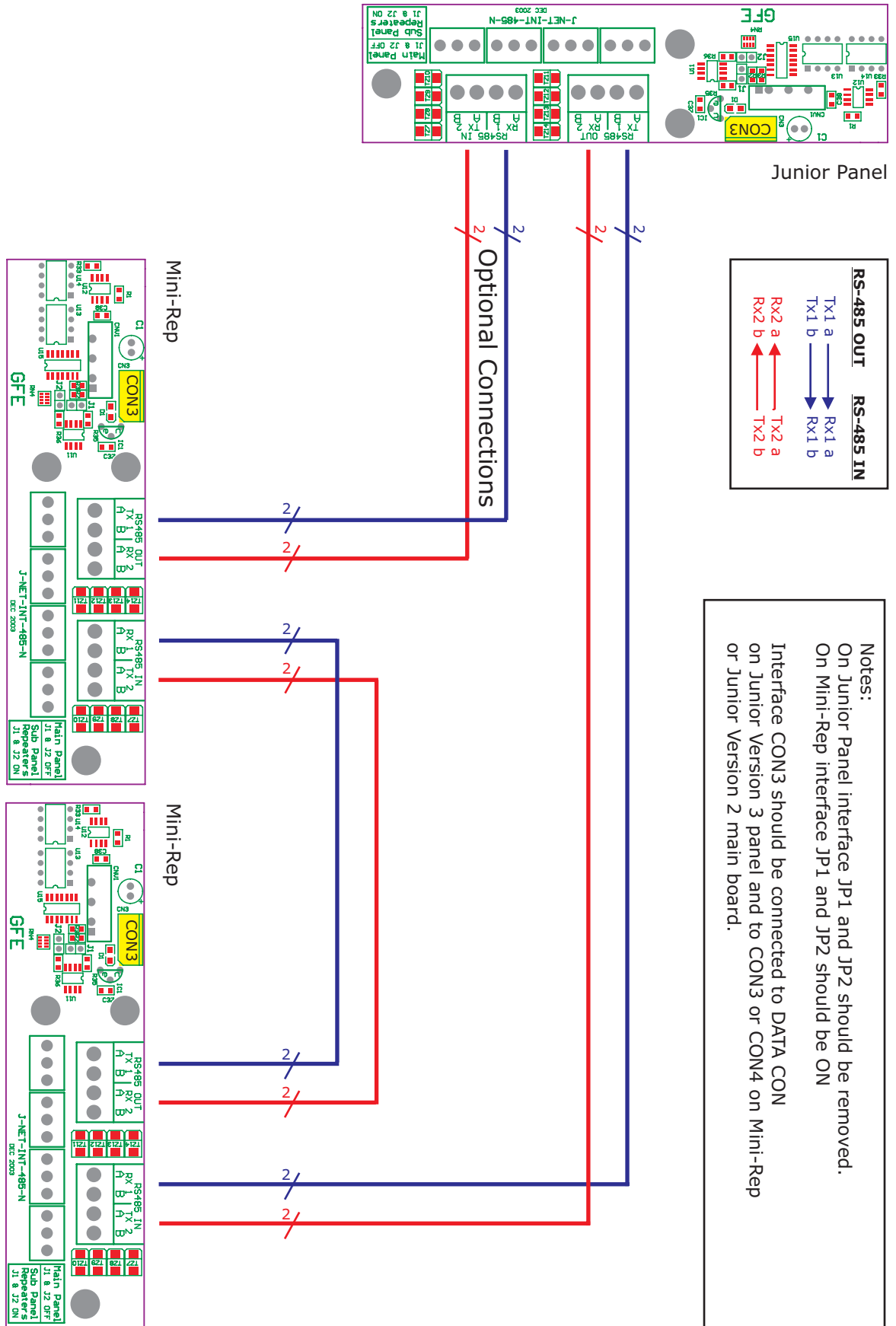

Figure 2 Junior Panel Multi - Mini-Repeater - Data Loop Connections

Notes:
 On Junior Panel interface JP1 and JP2 should be removed.
 On Mini-Rep interface JP1 and JP2 should be ON

Interface CON3 should be connected to DATA CON on Junior Version 3 panel and to CON3 or CON4 on Mini-Rep or Junior Version 2 main board.

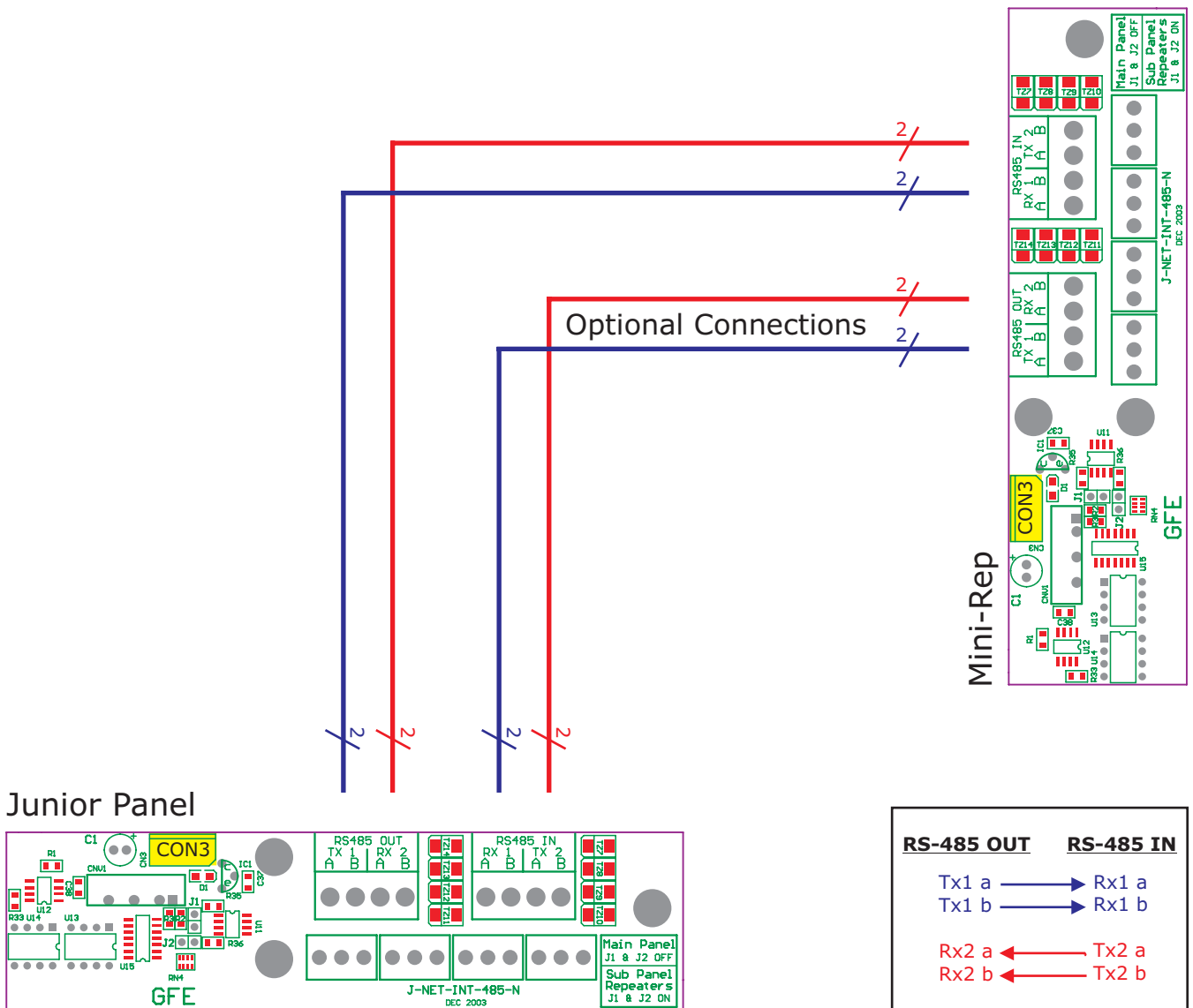

Figure 3 Junior Panel Mini-Repeater (Single) - Data Loop Conections

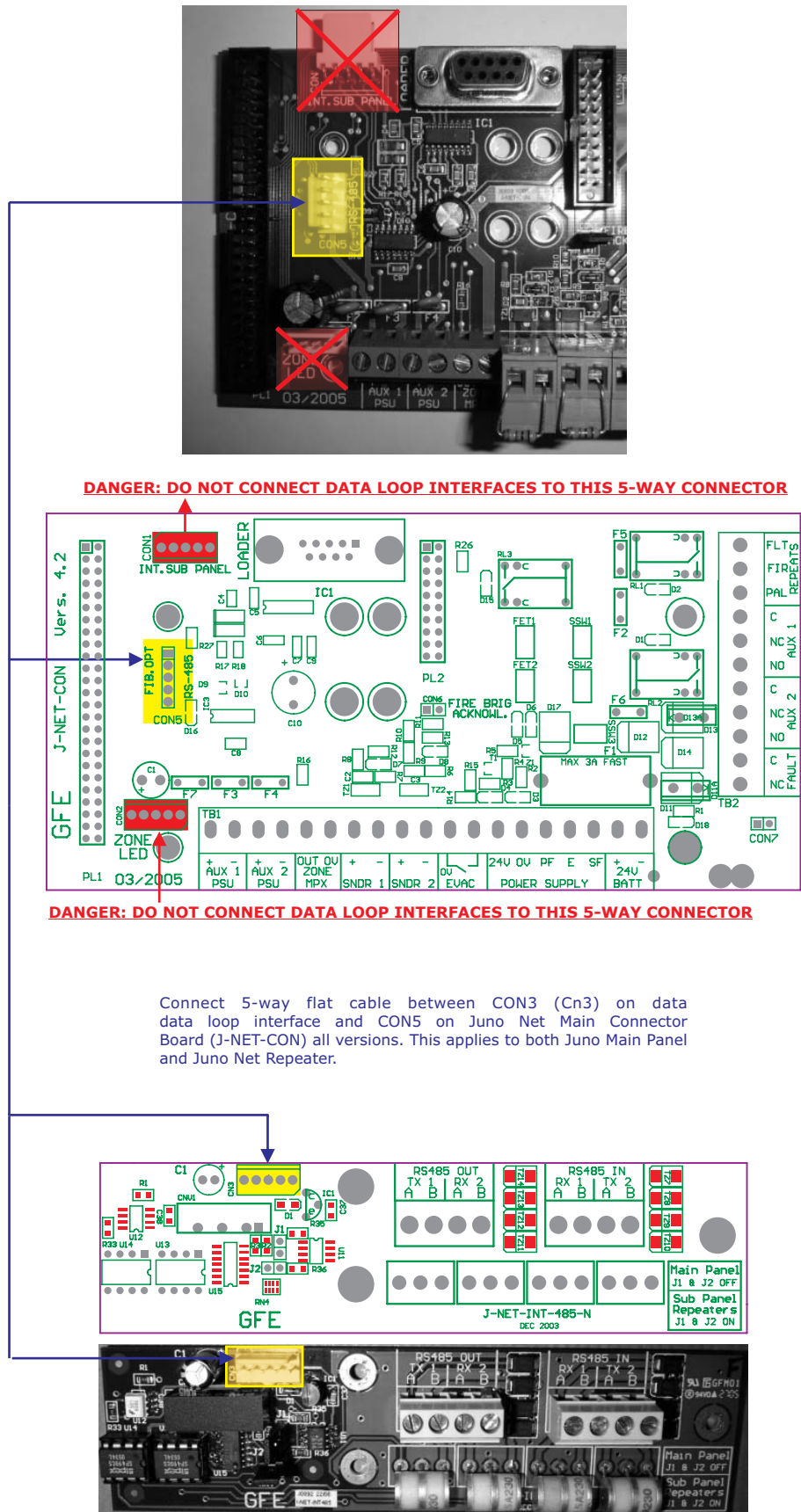

Figure 4 Juno Net (Main Panel or Repeater) Main Connector Board - Data Loop Interface Conections

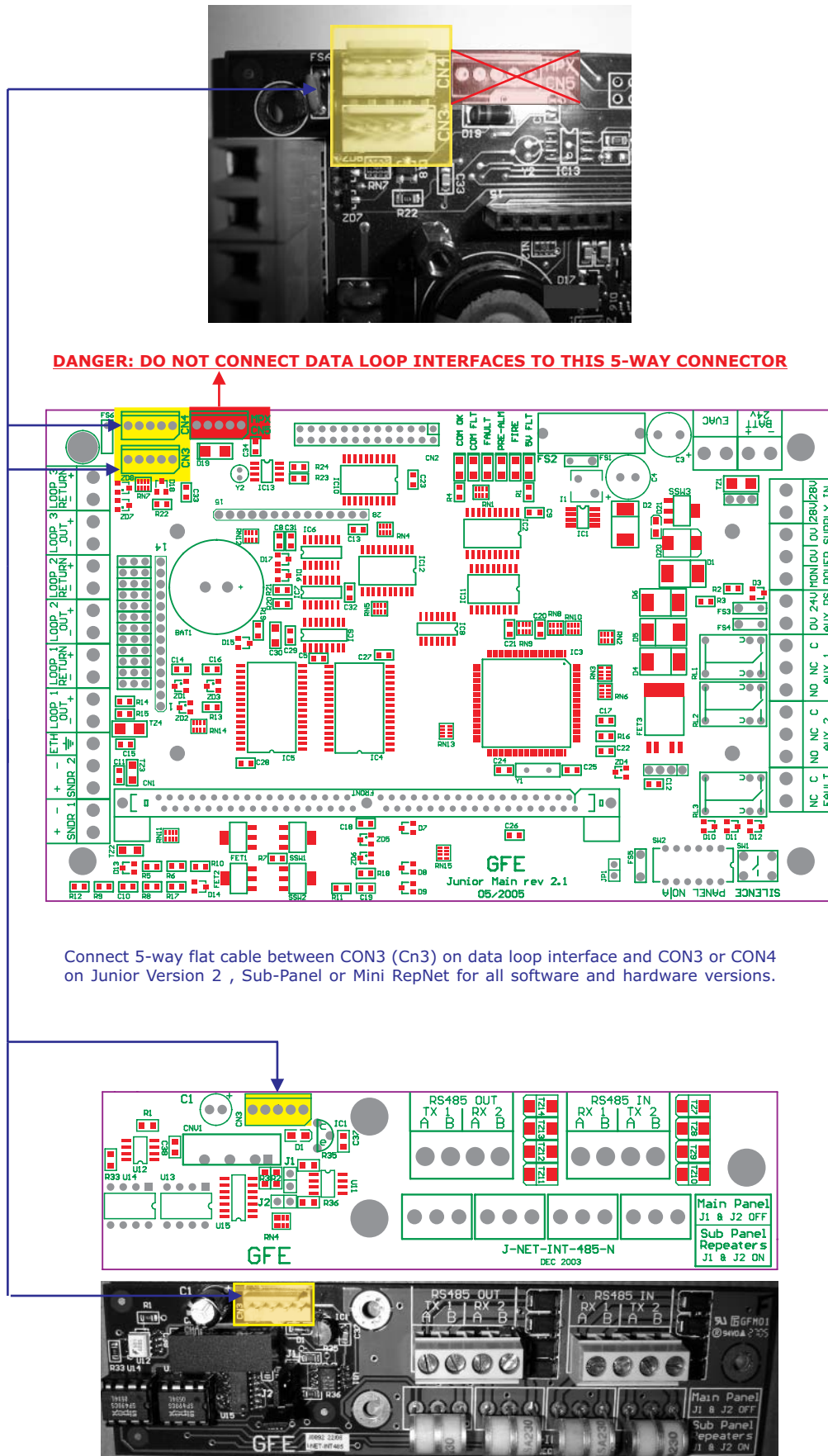
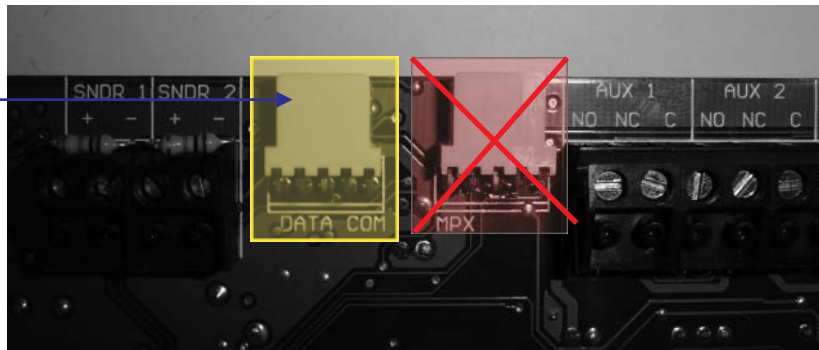
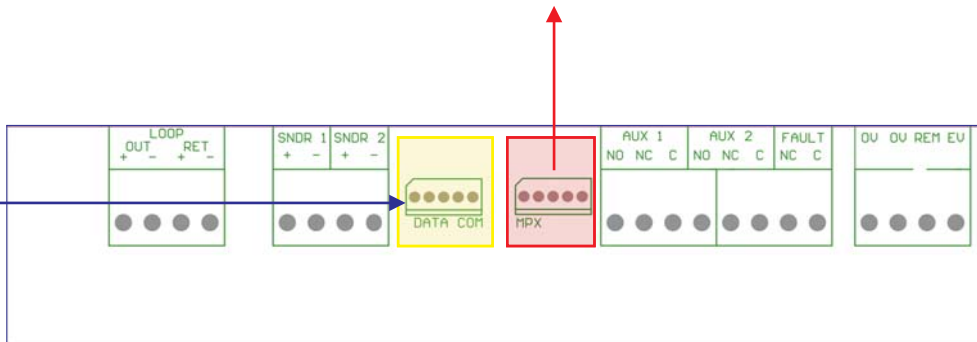

Figure 5 Junior Panel Version2, Sub-Panel or Mini-Rep - Data Loop Interface Conections



DANGER: DO NOT CONNECT DATA LOOP INTERFACES TO THIS 5-WAY CONNECTOR



Connect 5-way flat cable between CON3 (Cn3) on data loop interface and DATA COM connector on Junior Version 3 for all software and hardware versions.

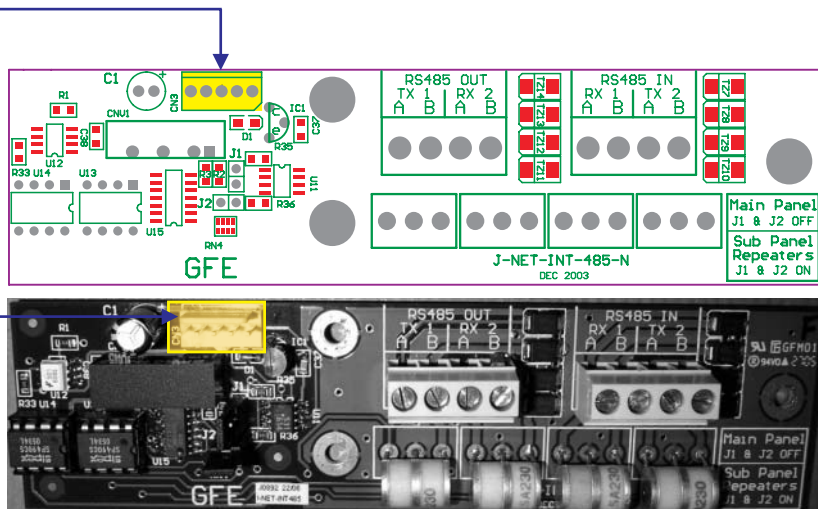

Figure 6 Junior Panel Version 3 - Mini-Rep - Data Loop Interface Conections