

The ETHM-1 Ethernet Module is a TCP/IP server. It enables the INTEGRA series control panels (program version 1.03 or later) to be operated via the Ethernet network. Data transmission in the network is coded by means of an advanced algorithm based on 192-bit key. The control panels can be operated via the Ethernet network with the use of PC computers or mobile phones.

When using the computer, the control panel can be operated from the DLOADX service program, GUARDX administrator program, as well as an Internet browser supporting the JAVA applications. The mobile phone uses a special JAVA application to operate the control panel.

Note: *The module enables only one user to be connected at a time. The next users will receive a message on busy status of the server.*

The module with firmware version 1.02 or later provides an option for the INTEGRA series control panels (program version 1.04 and next) to perform monitoring via the Ethernet network.

This manual refers to the ETHM-1 module with firmware version 1.02. Replacement of the module firmware is possible by means of the EtmFlash program, available on the website www.satel.pl

1. Description of electronics board

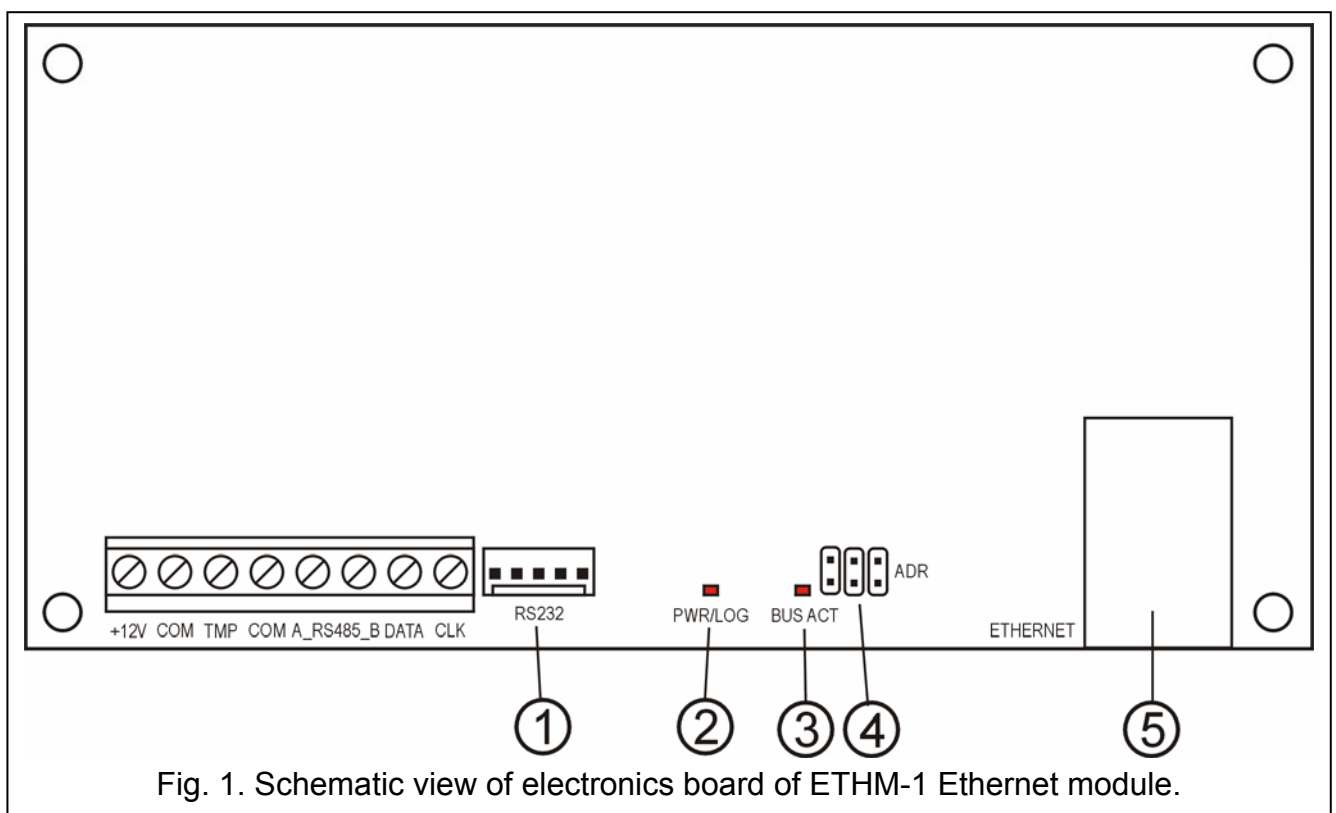

Legend:

- 1 – **RS-232 port** – enables the module to be connected to the control panel RS-232 port, so that the panel can be controlled via the Ethernet by means of the DLOADX program. Additionally, it makes possible to replace the module firmware. Connect the port to the

computer by means of the same cable that was used for programming the INTEGRA control panels from the computer, and then run the EthmFlash program.









- 2 – **PWR/LOG LED** – steady light indicates presence of the supply voltage; blinking LED indicates that the user has logged in to the server.
- 3 – **BUS ACT LED** – blinking LED indicates the process of communication between the panel and the module.
- 4 – **ADR pins for setting module address** (see MODULE ADDRESSING).
- 5 – **RJ-45 socket** – intended to connect Ethernet cable to the module. It is necessary to use a cable identical to that used to connect a computer to the network. The socket has two built-in LEDs. The green LED indicates connection to the network and transmission, and the yellow one – transmission rate in the network (10Mb/100Mb).

Description of terminals:

- +12V** – supply voltage input;
- COM** – common (ground);
- TMP** – input of module tamper circuit (NC) – connects the housing tamper contact; if not used, it should be **shorted to ground**;
- A_RS485_B** – RS-485 port terminals (not used);
- DATA, CLK** – communication bus – connects the module to the keypad bus of the control panel.

2. Module addressing

The address set on the module ADR pins must be different from those of the other modules, keypads, etc. connected to the control panel keypad bus. The address should be set as shown in Table 1.

Pins status	Module address
	0
	1
	2
	3
	4
	5
	6
	7



 – pins shorted
 – pins open

Table 1.

3. Installation

The module should be installed indoors, in spaces with normal air humidity. It is possible to install the module either in plastic (OPU-1 A) or metal (CA-64 OBU-EXA) housing.

Caution! Prior to hook up of the module to an existing security system, you must disconnect power supply of the whole system.

To install the ETHM-1 module in security system you should:

1. Set the module address by means of jumpers (see MODULE ADDRESSING).
2. Connect the module to the control panel keypad bus as shown in Table 2.

Module terminals	Mainboard terminals
+12V	+KPD
COM	COM
DATA	DTM
CLK	CKM

Table 2.

If necessary, the module supply (+12V) may be provided from an additional power supply unit installed in the system.

3. Connect the housing tamper contact to the TMP, COM terminals (or short the TMP terminal to the COM ground).
4. Connect the Ethernet cable to the RJ-45 socket.
5. If the control panel is to be operated via the network by means of the DLOADX program, connect the RS-232 ports of module and control panel with a cable made according to Fig. 2.

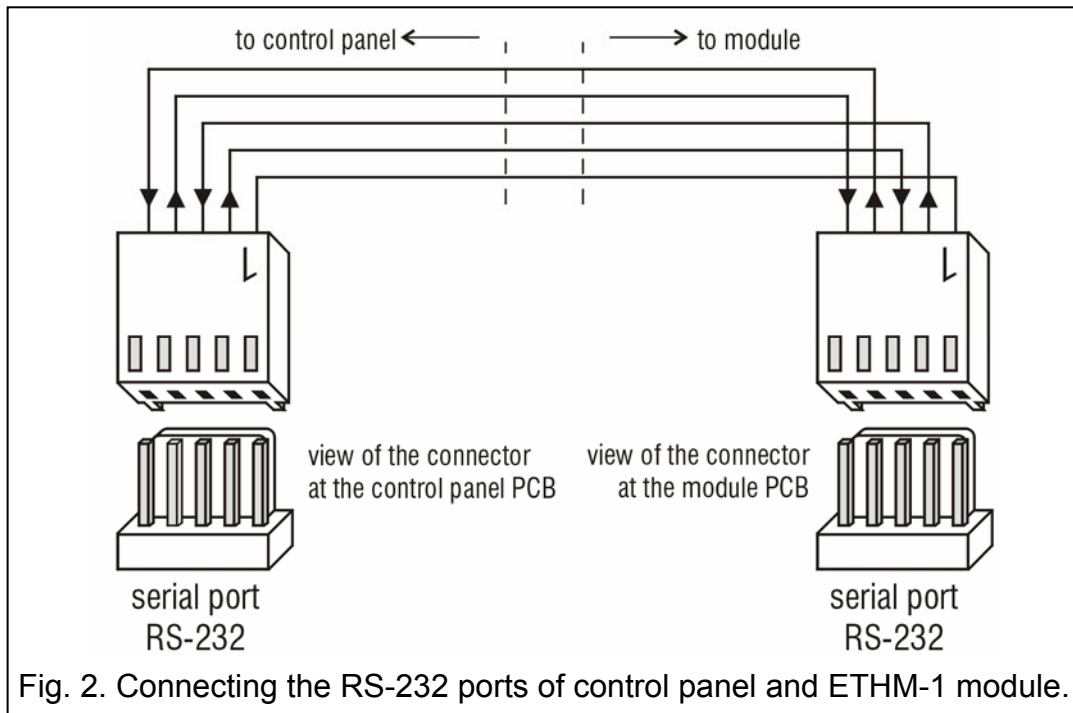

4. Starting the module

Note: In the systems having modules with own power supply, it is recommended that you start the panel first, and then, successively, the other system components.

1. Switch on power supply of the security system and the module (module power-up will be confirmed by the PWR/LOG LED going on).
2. Identify the new module in the security system by starting the LCD KEYPADS ID. service function in the keypad (→SERVICE MODE →STRUCTURE →HARDWARE →IDENTIFICATION). After successful identification, the "I" letter will be show on the keypad display under the module address.

Note: During the identification process, the control panel saves in module memory a special (16-bit) number, intended to check the module presence in the system. Replacement of the module with another one (even with the same address set on the jumpers) without a new identification will trigger the alarm (module tamper).

3. Program correct module settings (see DESCRIPTION OF SETTINGS) by means of the security system keypad in service mode, or using a computer with DLOADX program. If the module and the control panel are connected through RS-232 ports, disconnect the cable connecting the RS-232 ports of module and panel, and then connect the cable connecting the computer and the panel to the control panel RS-232 port.

Note: To obtain the network configuration data you should contact the network administrator.

4. Having configured the module operating settings, save the changes in the FLASH memory and terminate the DOWNLOADING function, if it has been started. If the cable connecting the module/panel RS-232 ports has been disconnected for the time of programming, it should be reconnected.

5. Description of settings

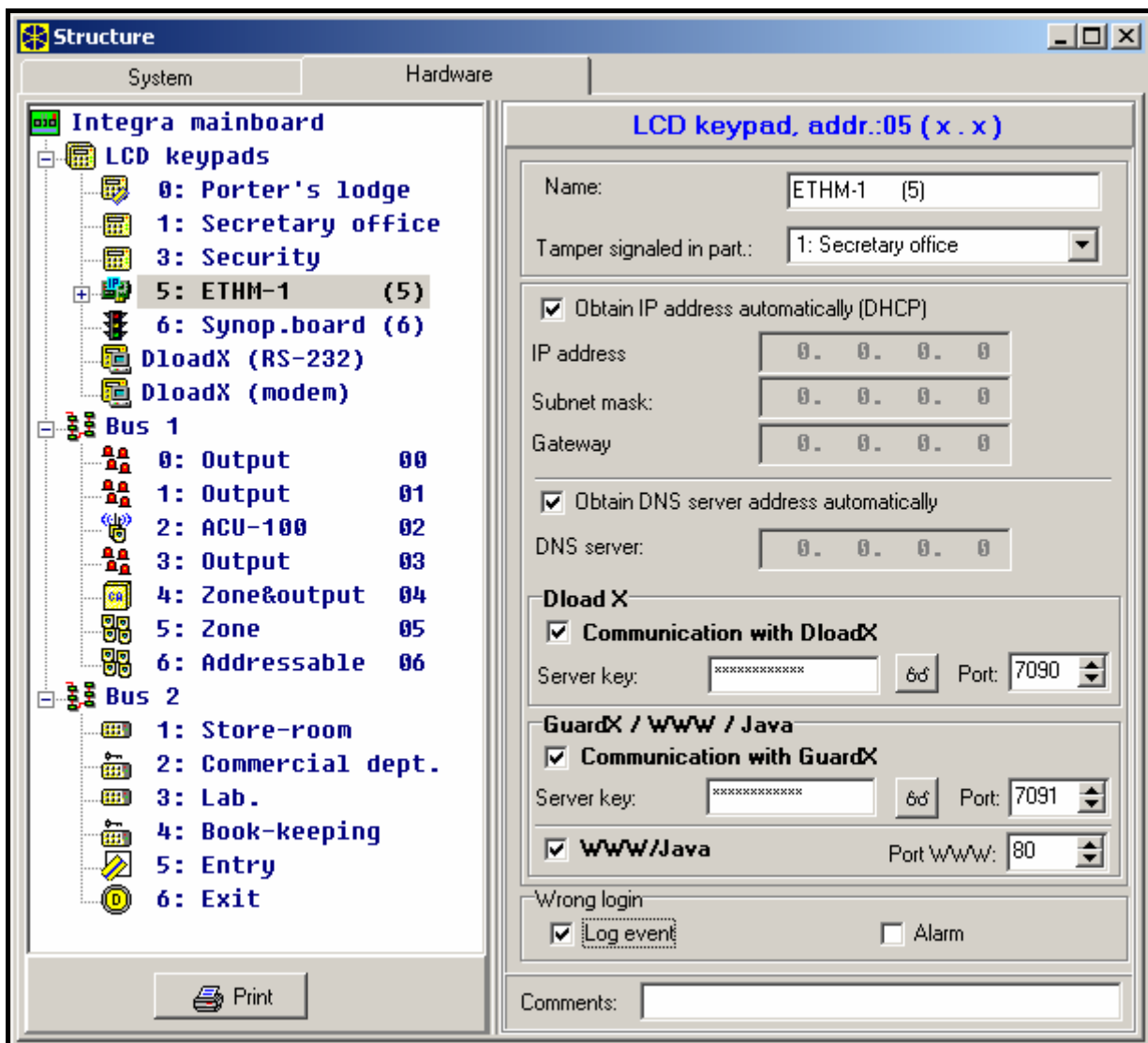

Fig. 3. Window of ETHM-1 module settings in DLOADX program.

The names of programmable options are given on the LCD keypad base. Additionally, descriptions of the DLOADX program options are shown in square brackets.

Use DHCP [Obtain IP address automatically (DHCD)] – if this option is activated, the module will automatically download data on IP address, subnet mask and gateway from DHCP server.

Note: *The IP address assigned to the module can be read by means of the IP/MAC ETHM-1 user function (→ TESTS). When establishing communication with the module, you must know the IP address. Hence it is recommended that the dynamically assigned IP address be always the same. By means of the same function it is possible to read module MAC number (after pressing ◀ or ▶ on the keypad).*

IP address – the IP address to be used by the module. The option is available when the function of automatic obtaining of the data from server is disabled.

Netmask [Subnet mask] – mask of the subnet the module operates in. The option is available when the function of automatic obtaining of the data from server is disabled.

Gateway – IP address of the network device that allows access to another computer or network. The option is available when the function of automatic obtaining of the data from server is disabled.

DHCP-DNS [Obtain DNS server address automatically] – with this option enabled, the module will automatically download DNS server address data from the DHCP server.

DNS [DNS server] – the DNS server to be used by the module. The function is available if the option of automatic server data downloading is disabled.

Port (WWW) – determines the number of network port on which the module login page in web browser will be displayed. By default, the port number is 80. However, if it is already taken up by another service (another web server), a different value must be entered. If the entered value is different from 80, then, when typing in the IP address of the ETHM-1 module in the browser, insert a colon and the port number at the end.

Port (DLOADX) – determines number of the port through which communication with the DLOADX program will take place.

Port (others) [GUARDX/WWW/JAVA] – determines number of the port through which communication with the other programs (GUARDX, JAVA application in the internet browser, JAVA application in the mobile phone) will take place.

Key (DLOADX) [DLOADX server key] – a sequence of 1 to 12 alphanumeric characters to define the key to code the data during communication with the DLOADX program.

Key GUARDX [GUARDX/WWW/JAVA server key] – a sequence of 1 to 12 alphanumeric characters to define the key to code the data during communication with the GUARDX program/JAVA application in internet browser/JAVA application in mobile phone.

Note: *For the best possible transmission security, it is recommended that you enter the key using the maximum number of characters.*

Connect DLOADX [Communication with DLOADX] – this option defines whether the control panel operation should be available from the DLOADX program.

Connect GUARDX [Communication with GUARDX] – this option defines whether the control panel operation should be available from the GUARDX program.

Connect Internet [WWW/JAVA] – this option defines whether the control panel operation should be available by means of the Internet/mobile phone JAVA applications.

Tamper [Tamper signaled in partition] – the option to indicate the partition where alarm will be triggered in the event of module tamper.

Fail. – event [Wrong login – Log event] – with this option selected, all unauthorized attempts to establish connection with the module will be saved in the events memory.

Fail. – alarm [Wrong login – Alarm] – with this option selected, all unauthorized attempts to establish connection with the module will trigger a tamper alarm. The option is available, when the “Fail. – event” [Wrong login – Log event] option is enabled.

6. Operating the control panel by means of DLOADX program

Note: The RS-232 port of the ETHM-1 module must be connected to the RS-232 port of the control panel.

In order to enable the control panel to be operated over the Ethernet by means of the DLOADX program, activate the following options in the control panel:

- MODEM ANSWERING
- EXTERNAL MODEM
- ISDN/GSM MODEM

The DOWNLOADING function in the control panel must be disabled.

The CONNECT DLOADX option must be enabled in the module settings.

In order to program the control panel via Ethernet using the DLOADX program, you should:

1. Launch the DLOADX program on the computer which is to communicate with the module over the Ethernet (the current DLOADX program can be downloaded from the website www.satel.pl).
2. Enter the following data in the "Account code and tel. numbers" window:
 - communication identifier of the INTEGRA control panel, corresponding to that saved in the panel;
 - communication identifier of the DLOADX program, corresponding to that saved in the panel;
 - IP address of the ETHM-1 module;
 - port – identical to that programmed in the module for communication with the DLOADX program;
 - server key – identical to that programmed in the module for communication with the DLOADX program.

Note: After three following connection attempts using an incorrect key, the module will block the communication with the computer for approx. 20 minutes.

The screenshot shows a dialog box titled "Account code and tel. no" with a close button (X) in the top right corner. It contains four sections, each with a blue header and a "Go" button (represented by a small icon):

- Panel Integra:** "Communication Identity:" (masked with asterisks) and "Panel's tel. no:" (empty text box).
- PC - DloadX:** "Communication Identity:" (masked with asterisks) and "PC phone number:" (empty text box).
- PC - GuardX:** "Communication Identity:" (masked with asterisks) and "PC phone number:" (empty text box).
- TCP/IP connection:** "IP address" (192.168.1.174), "Port:" (7090), and "Server key:" (masked with asterisks).

At the bottom center, there is an "OK" button with a green checkmark icon.

Fig. 4. Window showing an example of communication settings in DLOADX program.

3. Select "TCP/IP" in the "Connection" menu. The "TCP/IP connection" window will open. Press the "Connect" button.

Establishment of a successful connection with the control panel will be confirmed by display of a suitable message. Having read the control panel settings, you can proceed to programming new ones.

Note: *If the ETHM-1 module settings are changed during programming, connection with the control panel may be lost.*

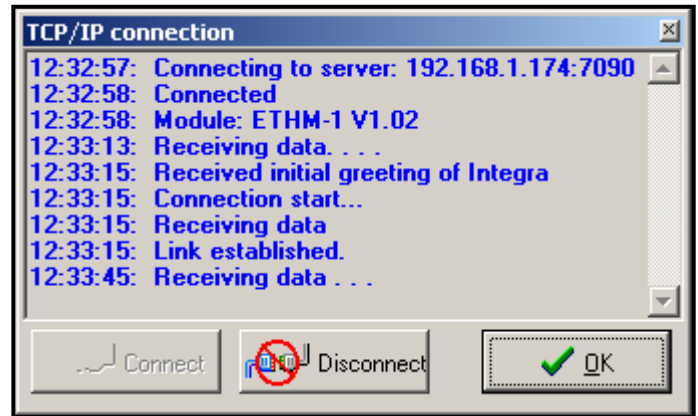

Fig. 5. "TCP/IP connection" window in the DLOADX program, with messages displayed when establishing communication with the panel.

7. Operating the control panel by means of GUARDX program

The CONNECT GUARDX option must be enabled in the module settings.

In order to operate the control panel over Ethernet by means of the GUARDX program, you should:

1. Start the GUARDX program on the computer which is to communicate with the module via Ethernet (you can download the current GUARDX program from the website www.satel.pl).
2. The program window will appear. Select "TCP/IP connection" in the "Connection" field.

3. Press the "Configuration" button. Enter the following data in the window that will appear:

- INTEGRA communication identifier, corresponding to that saved in the control panel;
- IP address of the ETHM-1 module;
- port – identical to that programmed in the module for communication with the GUARDX program;
- server key – identical to that programmed in the module for communication with the GUARDX program.

Note: *After three following connection attempts using an incorrect key, the module will block the communication with the computer for approx. 20 minutes.*



Fig. 6. Window with an example of configuration of TCP/IP connection in GUARDX program.

4. Close the connection configuration window and press the "Start" button.

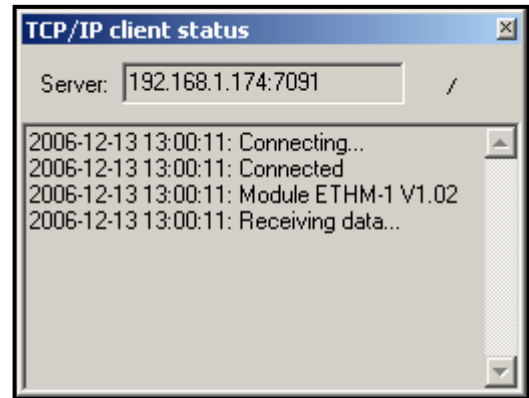

Fig. 7. GUARDX program window to inform about status of communication with the module.

5. After communication with the control panel is established, a window will appear in which you should enter a password with suitable authority level to get access to the control panel operation. When a valid password is entered, a message will appear that connection with the control panel has been established. Then you can proceed to operating the alarm control panel.

8. Operating the control panel by means of website JAVA application

The CONNECT INTERNET [WWW/JAVA] option must be enabled in the module settings.

The JAVA application requires that the JAVA Virtual Machine be installed on the computer. The program can be downloaded from the website www.sun.com.

In order to operate the alarm control panel via Ethernet by means of the website JAVA application, you should:

1. Start the web page browser.
2. In the address field, enter the IP address of the ETHM-1 module.
3. Enter the following information on the page to appear in the browser:
 - server key – identical to that programmed in the module for communication with the Web;

Note: After three following connection attempts using an incorrect key, the module will block the communication with the computer for approx. 20 minutes.

- port – identical to that programmed in the module for communication with the GUARDX program and JAVA application (in LCD keypad is described as PORT (OTHERS)).

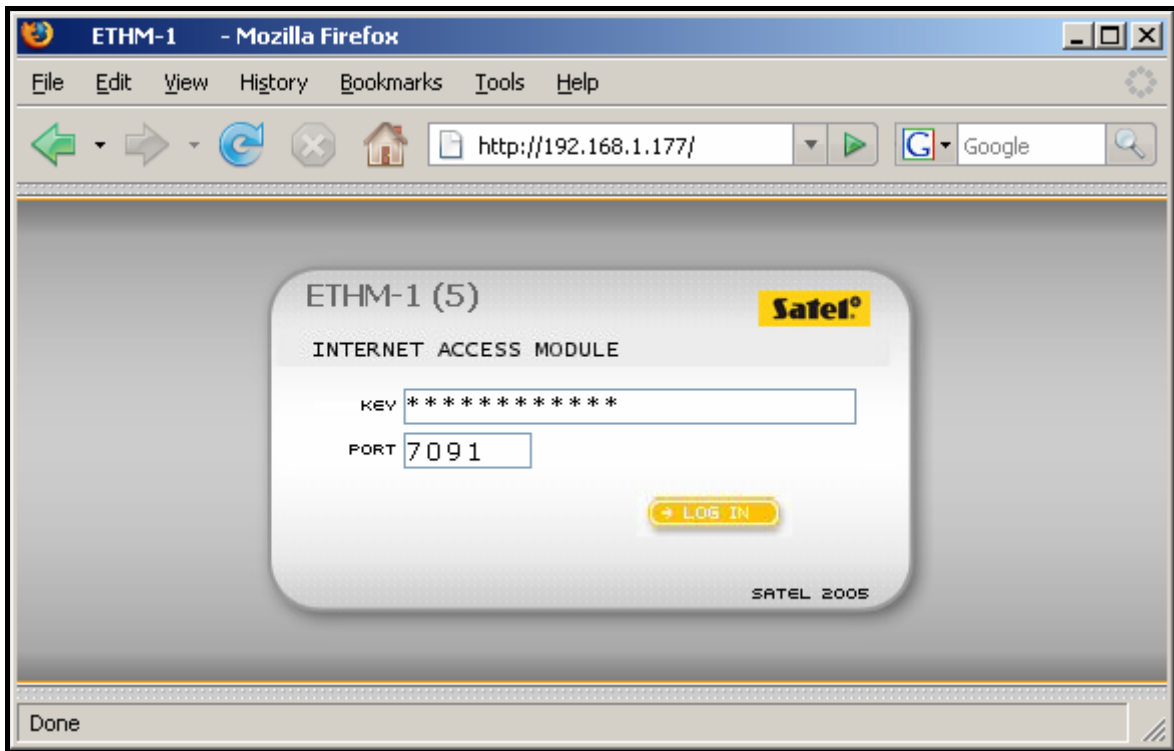

Fig. 8. Window of internet browser with the ETHM-1 module login page. Having entered the data, click on the "Log in" button.

4. A virtual keypad will appear in the window, thus allowing you to operate the control panel similarly as with the LCD keypad. You can use the LCD keypad either by means of your mouse or by pressing the appropriate keys on the keyboard.

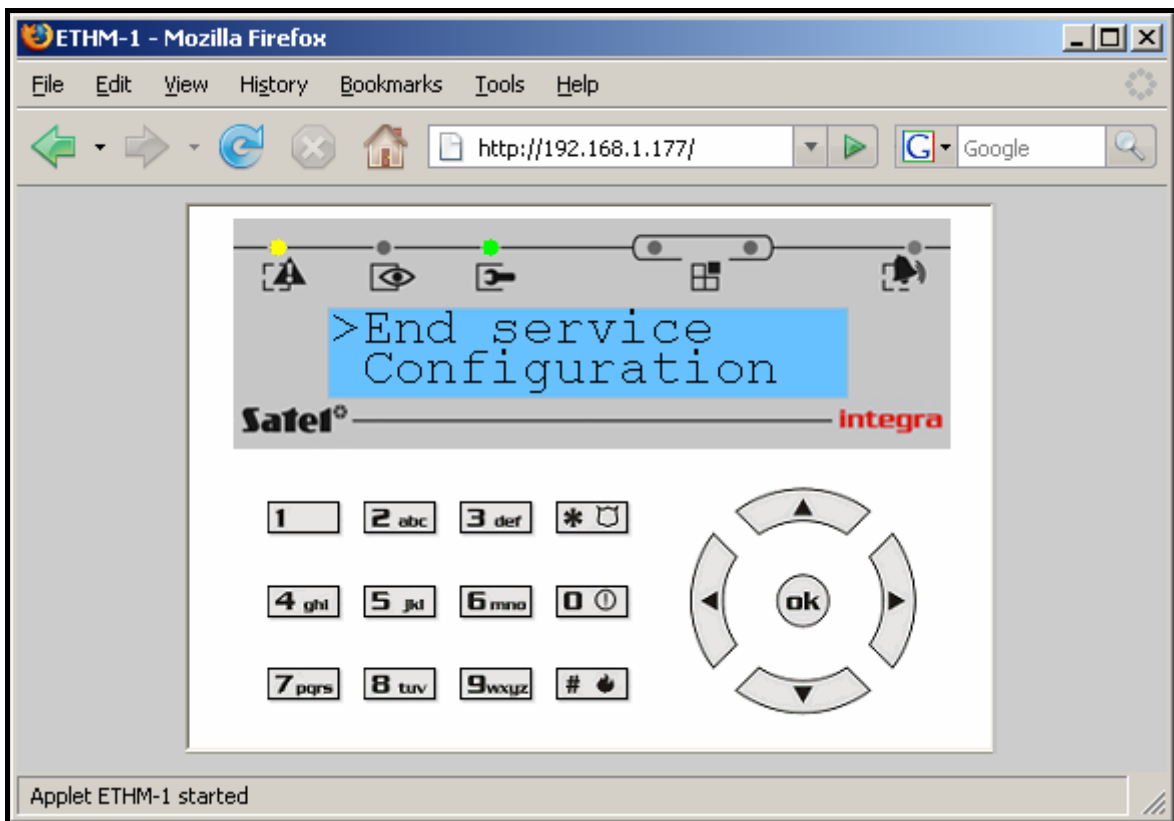

Fig. 9. Virtual keypad to enable the security system to be operated from web page.

9. Operating the control panel by means of mobile phone JAVA application

The CONNECT INTERNET [WWW/JAVA] option must be enabled in the module settings.

The mobile phone from which the control panel is to be operated must have access to the Internet and be JAVA compatible.

The JAVA application for operating the control panel should be downloaded from the website www.satel.pl. The application must be suitably selected to match the mobile.

To operate the control panel from a mobile phone by means of the JAVA application, you should:

1. Set the connection profile to be used by the application.
2. When the application is run for the first time, a screen is displayed where you can enter information on the security system you wish to be connected to:
 - name for the security system (to facilitate its later identification);
 - IP address of the ETHM-1 module;
 - port – identical to that programmed in the module for communication with JAVA application;
 - key – identical to that programmed in the module for communication with JAVA application.

Note: After three following connection attempts using an incorrect key, the module will block the communication with the phone for approx. 20 minutes.

All the fields being filled up, the system data can be saved in the telephone memory (Options →Save) to make next connection easier. Having saved the data in the phone memory, the application will automatically proceed to the list of saved systems. At subsequent starts, the application will immediately display the list of saved systems. The data saved in the phone memory can be modified (Options →Edit) or deleted (Options →Delete). You can also add new system data at any time (Options →New).

3. Having entered the data (without saving) or having selected data from the list, you can connect to the security system by means of the module (Options →Start).
4. After connection is established with the security system, the current time downloaded from the system should be displayed. You can proceed to operating the security system, using the telephone keypad in the same way as the LCD keypad.



Fig. 10. View of the cellular phone with JAVA application running.

10. Technical data

Rated supply voltage	12V DC \pm 15%
Average current consumption	112mA
Operating temperature range.....	0 \div 55°C
Electronics board dimensions	68x140 mm
Weight.....	64g

The latest EC declaration of conformity and certificates are available for downloading on our website www.satel.pl



SATEL sp. z o.o.
ul. Schuberta 79
80-172 Gdańsk
POLAND
tel. + 48 58 320 94 00
info@satel.pl
www.satel.pl