

# FAAC

---

## FAAC CITY

---

**Automatic concealed bollards  
275 H600 and 275 H800  
with pit**

---



## Technical installation manual

- **CE Declaration of conformity**
- **Warnings for the installer**
- **Bollard technical data**
- **Preparing and installing the bollard**
- **Electric connection of bollard to 462DF equipment and relevant settings**
- **Installation of safety inductive loops**
- **Manual lowering operation**
- **Maintenance procedures**



## **CE DECLARATION OF CONFORMITY FOR MACHINES** **(DIRECTIVE 98/37/CE)**

**Manufacturer:** FAAC S.p.A.

**Address:** Via Benini, 1 - 40069 Zola Predosa BOLOGNA - ITALIA

**Declares that:** The FAAC CITY model operator

- is built to be incorporated into a machine or to be assembled with other machinery to create a machine under the provisions of Directive 98/37/CE;
- conforms to the essential safety requirements of the other following EEC directives:

73/23/EEC and subsequent amendment 93/68/EEC.  
89/336/EEC and subsequent amendment 92/31/CEE and 93/68/EEC

Furthermore, the manufacturer declares that the machinery must not be put into service until the machine into which it will be incorporated or of which it will become a part has been identified and its conformity to the conditions of Directive 98/37/CE has been declared.

Bologna, 01 January 2005

The Managing Director  
A. Bassi

A handwritten signature in black ink, appearing to be 'A. Bassi', written over a light grey circular stamp.



## WARNINGS FOR THE INSTALLER - GENERAL SAFETY OBLIGATIONS

1	<b>IMPORTANT! To ensure the safety of people, it is important that all the instructions be carefully observed. Incorrect installation or incorrect use of the product could cause serious harm to people.</b>	14	Make sure that the earthing system is workmanlike built and connect the metal parts to it.
2	<u>Carefully read the instructions</u> before beginning to install the product.	15	The automated system consists of an intrinsic anti-crushing safety device controlling the torque. However, you must check its action threshold as mentioned in the Regulations in point 10.
3	Packing materials (plastic, polystyrene, etc.) must not be left within the reach of children, because these materials are potential danger sources.	16	Safety devices (EN 12978 standard) protect possible danger areas against <b>Mechanical movement risks</b> . e.g. crushing, carrying away and shearing.
4	Keep the instructions for future reference.	17	Use of at least one warning light is recommended for every system (e.g. a built-in flashing light on the bollard head), a warning sign, in addition to the devices mentioned in point "16".
5	This product was designed and built exclusively for the use indicated in this documentation. Any other use not expressly indicated could compromise the integrity of the product and/or be a source of danger.	18	For maintenance, strictly use original FAAC S.p.A. parts.
6	FAAC S.p.A. declines any responsibility due to improper use or use other than the use for which the automated system is intended.	19	FAAC S.p.A. declines all responsibility on the safety and efficient operation of the automated system, if system components not produced by FAAC S.p.A. are used.
7	Do not install the equipment in an explosive atmosphere. the presence of gas or inflammable fumes is a serious danger to safety.	20	Do not in any way modify the components of the FAAC CITY automated system.
8	For non-EU countries, to achieve an adequate safety level, the above mentioned standards must be observed in addition to the national standard references.	21	The installer must supply to the user Customer, all the information about the manual lowering of the bollard in case of an emergency, and must hand over to the System User the warning handbook which accompanies the product.
9	FAAC S.p.A. is not responsible for the non-observance of good workmanship in installing FAAC CITY products and the relevant accessories, or for any deformation which may occur through use.	22	Do not allow children or persons to stay near the bollard, especially while it is in operation.
10	The installation must be carried out by observing the current regulations in force.	23	Keep radio controls or other pulse generators away from children, to prevent the automated system from being activated involuntarily.
11	Before attempting any action on the system, cut out the electrical power supply.	24	The FAAC CITY bollard must be transited over only when the device is completely lowered.
12	Install an all-pole switch on the electricity supply line for the automated system, with contact opening distance of 3 mm or more. We advise you to use a 6A differential thermal breaker with all-pole switching.	25	The User must not in any way attempt to repair or to take direct action and must contact qualified authorised personnel only.
13	Make sure that a differential switch with a threshold of 0.03A is installed upstream of the system.	26	<b>Anything not expressly specified in these instructions is not permitted.</b>



## TECHNICAL SPECIFICATIONS FOR FAAC CITY 275 H600 AND 275 H800

Motion criterion	<b>Hydraulic</b>
Driven cylinder	<b>Fe37<sup>*1</sup> steel - thickness 6 mm</b>
Treatment of drive cylinder	<b>Polyester powder paint, dark grey metallised colour<sup>*2</sup></b>
Driven cylinder diameter	<b>275 mm.</b>
Driven cylinder stroke	<b>600mm (275 H600) and 800 mm. (275 H800)</b>
Cylinder top part (head)	<b>Anticorodal case hardened aluminium</b>
Cylinder surface treatment	<b>Polyester powder paint, light grey metallised colour</b>
Descent time	<b>9 sec. (275 H600) - 12 sec. (275 H800)</b>
Rise time	<b>9 sec. (275 H600) - 12 sec. (275 H800)</b>
Hydraulic pump	<b>Power supply 230V +6/-10% 50Hz</b>
Protection class	<b>IP 67</b>
Capacitor for pump	<b>16 µF</b>
Absorption	<b>220W</b>
Work frequency	<b>Intensive use</b>
Refracting adhesive band	<b>Standard height 80 mm</b>
Operating temperature	<b>- 40°C + 70°C<sup>*3</sup></b>
Total weight with pit	<b>Kg. 180</b>
Manual lowering operation	<b>YES<sup>*4</sup></b>
Impact resistance	<b>6,000 joule (FE37 steel - thickness 6 mm.)</b>
Dimensions of pit to be walled in	<b>560 x 560 x 1020 (275 H600) 560 x 560 x 1220 (275 H800)</b>
Standard length of connected cable	<b>10 mt.<sup>*5</sup></b>

\*<sup>1</sup> optional article: FE37 10 mm thick steel or 6 mm thick AISI 304 stainless steel

\*<sup>2</sup> optional article: customised sprayed paint in RAL colour scale

\*<sup>3</sup> optional article: heating elements (recommended for temperatures below -15°C to limit ice forming on the cylinder)

\*<sup>4</sup> optional article: automatic lowering device in case of a black-out

\*<sup>5</sup> optional article: lengths up to 30 mt to order.



**AUTOMATIC BOLLARDS WITH PIT**  
**FAAC CITY 275 H600 and 275 H800**  
**INSTALLATION LAY-OUT**

- 1) Make sure that the installation point of the FAAC CITY bollard is not in a valley zone. In a situation of this kind, the FAAC CITY bollard must be partially protected, by surrounding it with a drainage channel, equipped with a covering grating.
- 2) Excavate down to a depth of about **1.30 m** (275 H600) or about **1.50 m** (275 H800); the cross-section must have a side of about **1 m** (fig. 1 and fig. 2).
- 3) Make sure that the soil has good drainage capacity: pour about 40 litres of water in the excavation and check if it empties within 30 minutes. If it does not, construct the rain water discharge by using a 60 mm diameter pipe connected to the sewage system or, alternatively, connected to a pit, equipped with an emptying system (an electric pump for example) of greater depth than the FAAC CITY pit, which collects and discharges rain water.
- 4) Distribute gravel (with grain diameter of about 8 - 20 mm) to a thickness of about **30 cm**, taking care to compact it well, to avoid future "settling shrinkage".
- 5) Lay the metal pit complete with sub-frame, taking care to place it perfectly vertical. The top level of the sub-frame must be positioned about 10 mm higher than the tread surface (to limit entry of rainwater into the pit). **Position the pit, checking the position of the reference on the sub-frame in relation to the transit direction (fig.1 and fig. 2).**
- 6) When the pit has been installed, lay a flexible sheath (with 45 mm inside diameter) from the electrical connection in the pit to the motion control station.
- 7) Distribute concrete all around the pit, up to about 10cm from the tread surface dimension, making sure that the rag-bolts supplied with the pit are appropriately positioned. When the pit has been installed, finish the road surface with the same type of material (fig. 3 and fig. 4).
- 8) Lay the pipes required for connecting the management station to any additional equipment (e.g. 'traffic lights' - inductive loops - card reader etc.) and to any other bollards present, and prepare the electrical and earthing connections (fig. 5).

**N.B.:** all pipes must be laid observing regulations in force.

FAAC CITY 275 H600 BOLLARD  
 INSTALLATION DIAGRAM FOR METAL ENCLOSURE

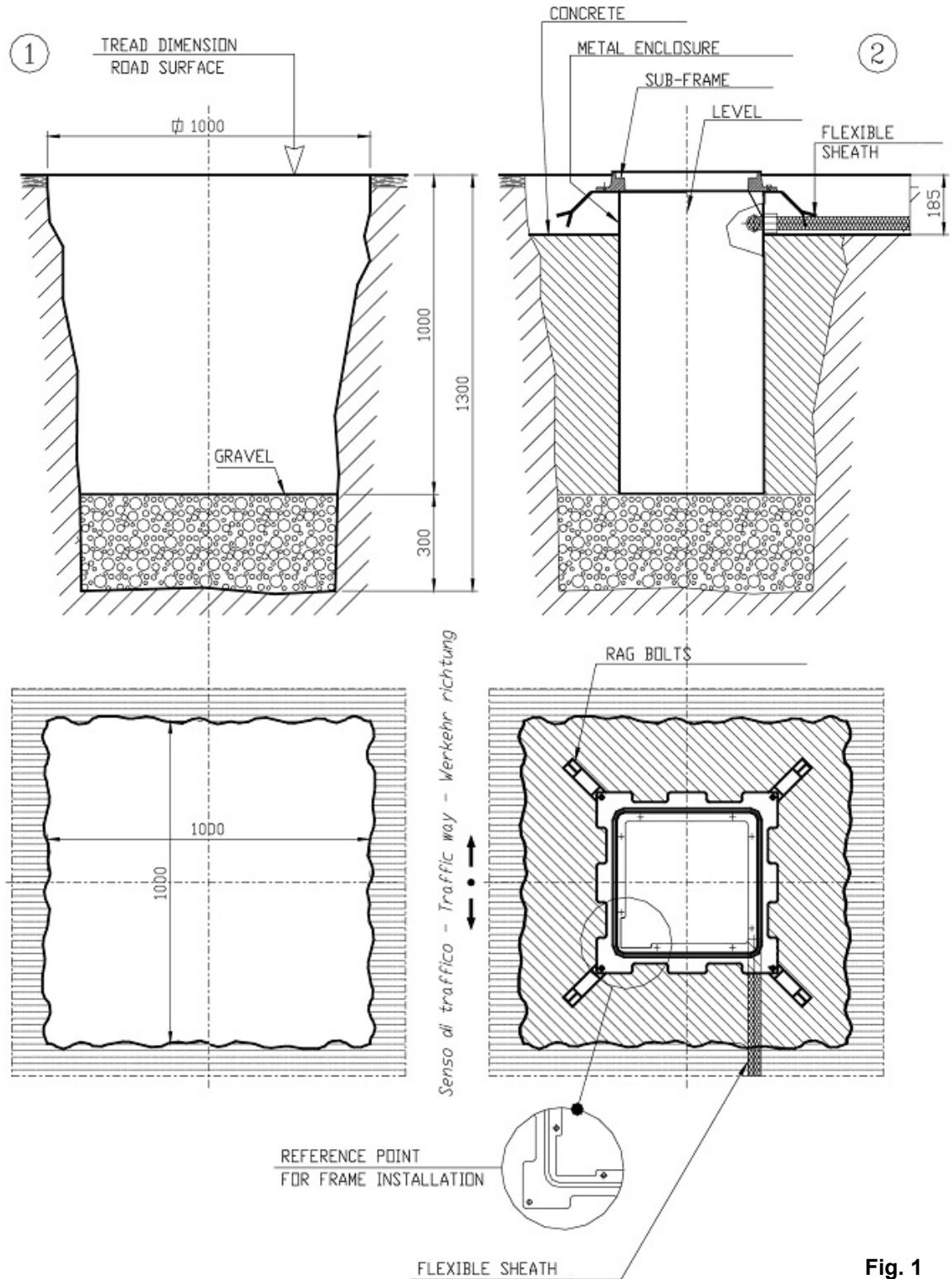

Fig. 1

FAAC CITY 275 H800 BOLLARD  
 INSTALLATION DIAGRAM FOR METAL ENCLOSURE

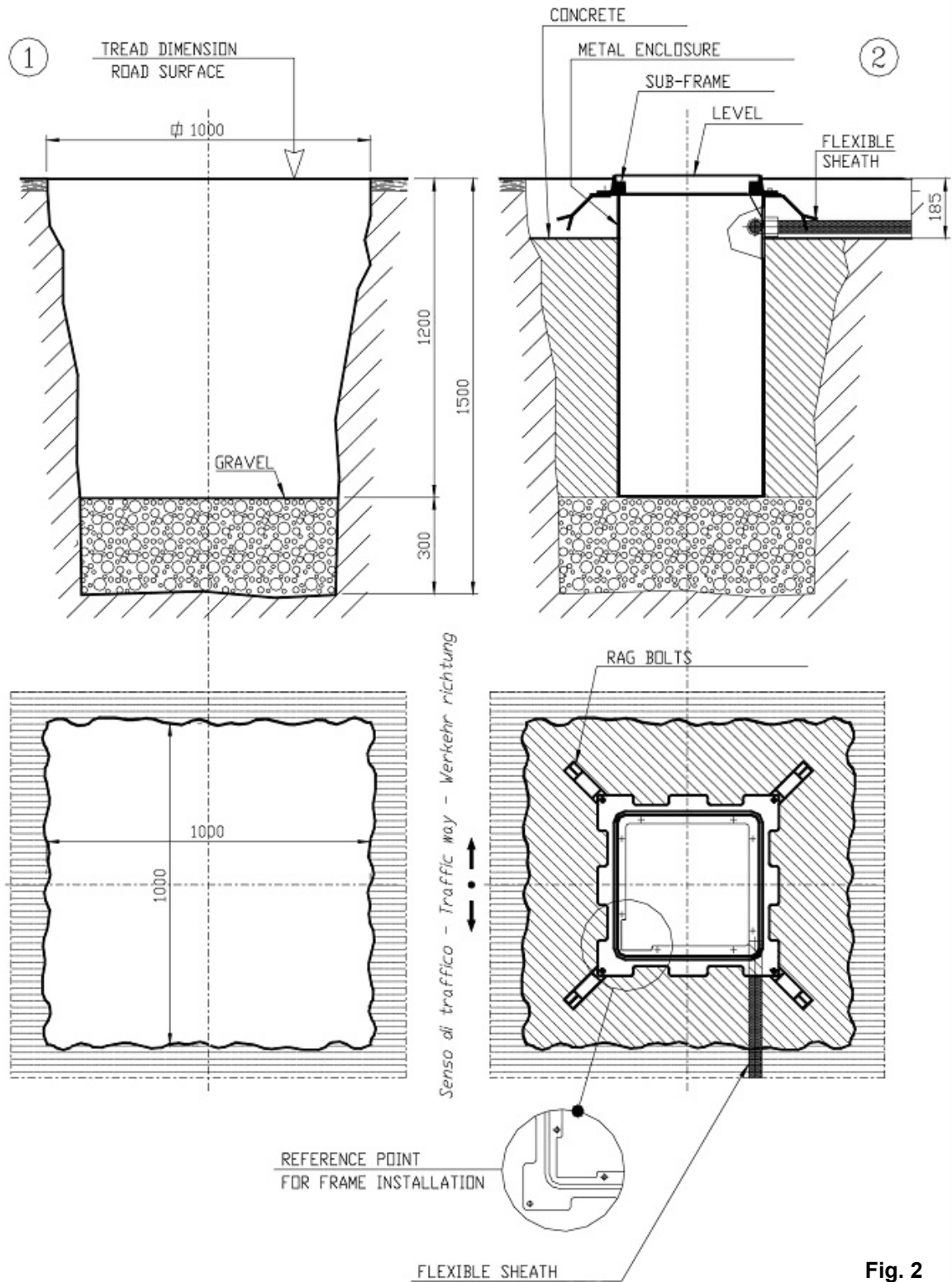

Fig. 2



FAAC CITY 275 H600 BOLLARD  
 INSTALLATION DIAGRAM FOR METAL ENCLOSURE

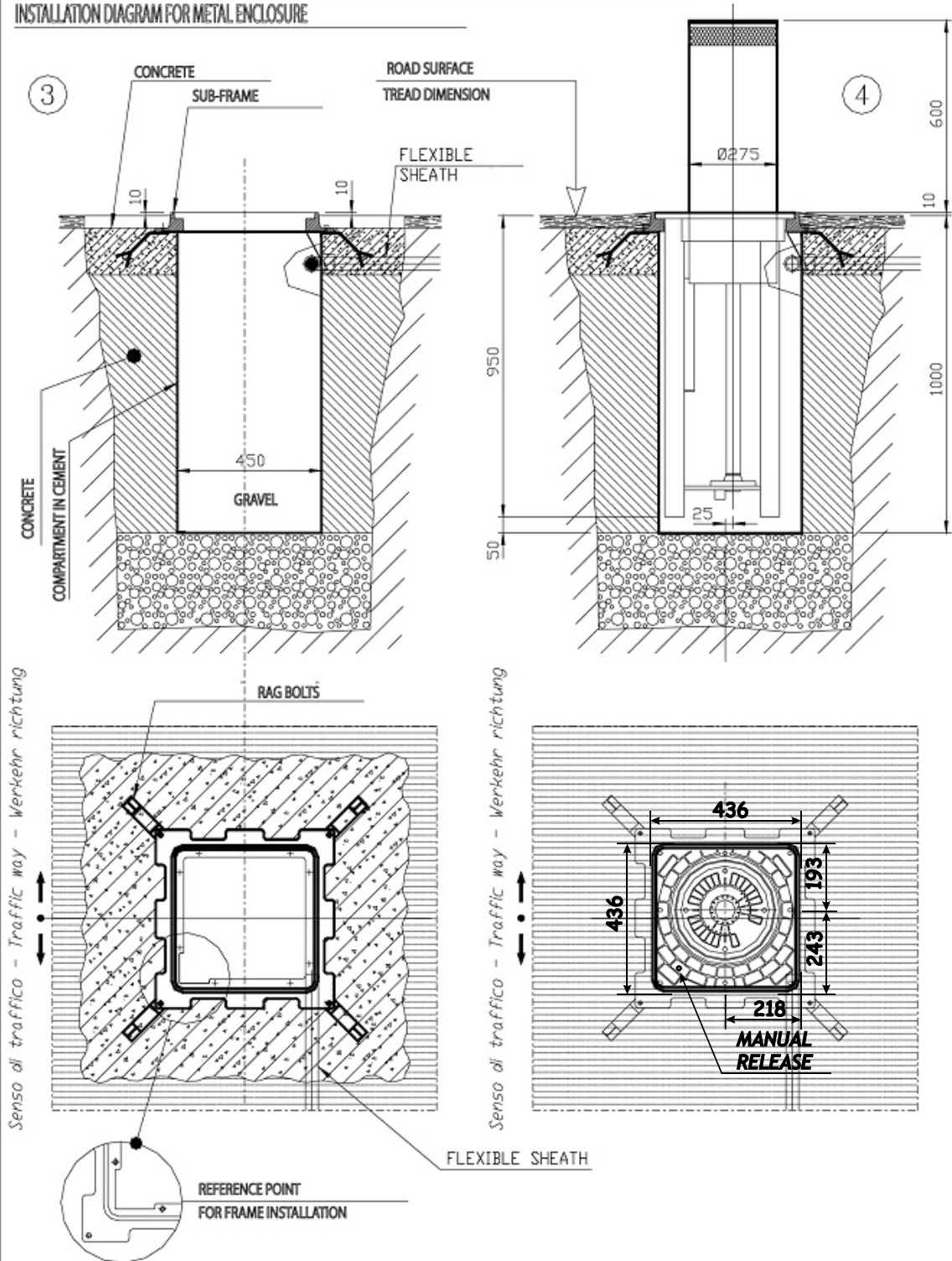

Fig. 3

FAAC CITY 275 H800 BOLLARD  
 INSTALLATION DIAGRAM FOR METAL ENCLOSURE

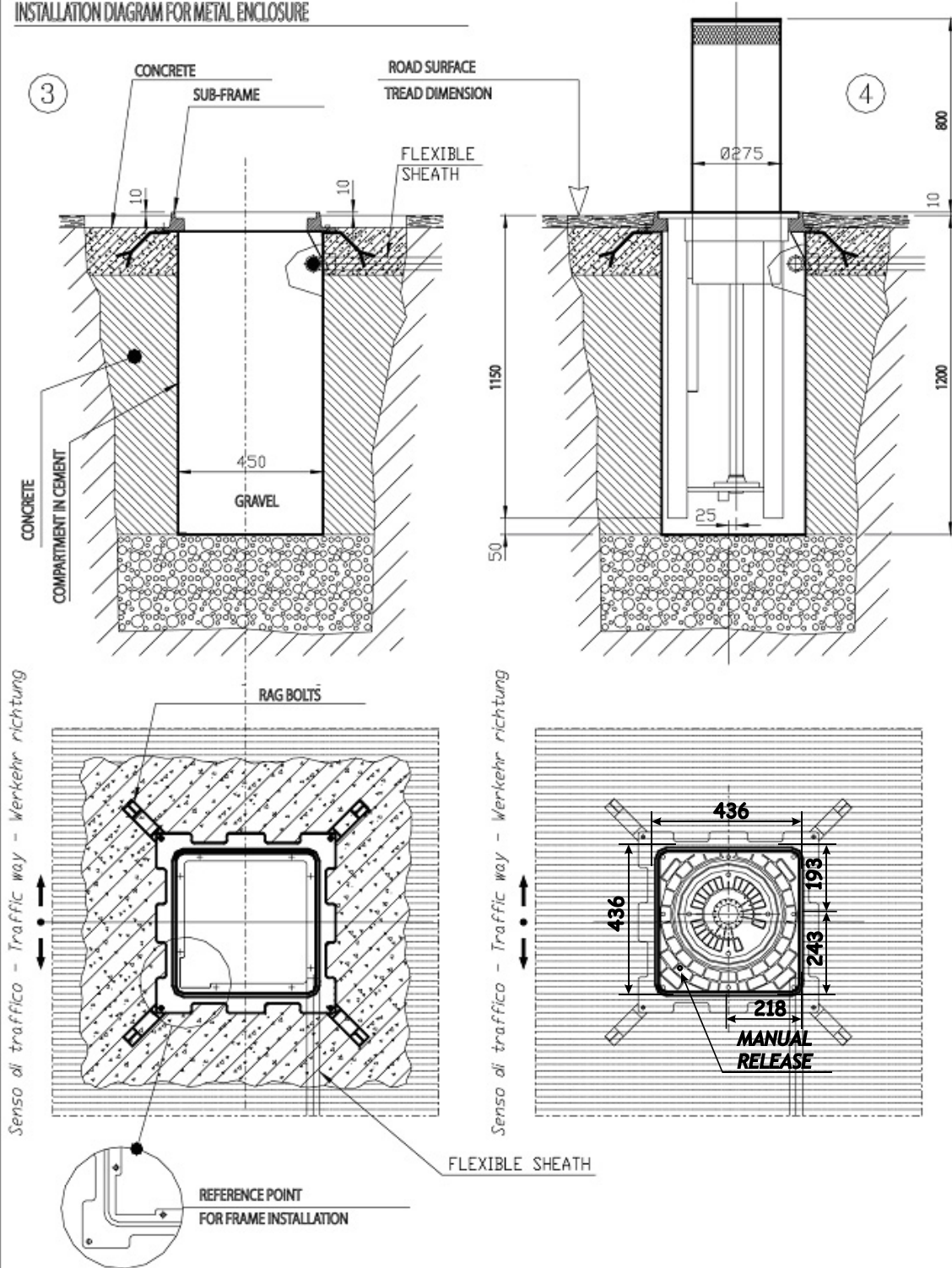

Fig. 4

FAAC CITY H600/H800 BOLLARD  
MULTIPLE INSTALLATION DIAGRAM

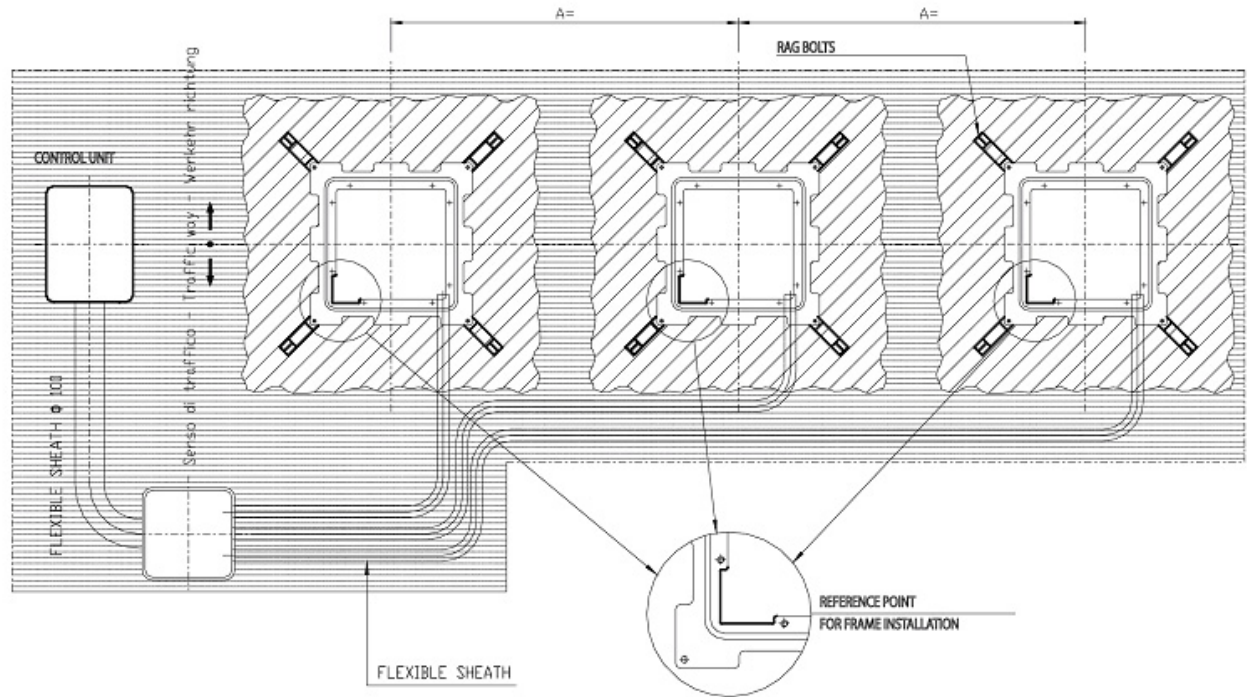

Fig. 5

## CONNECTION LAY-OUT FOR PIT - EQUIPMENT 462DF

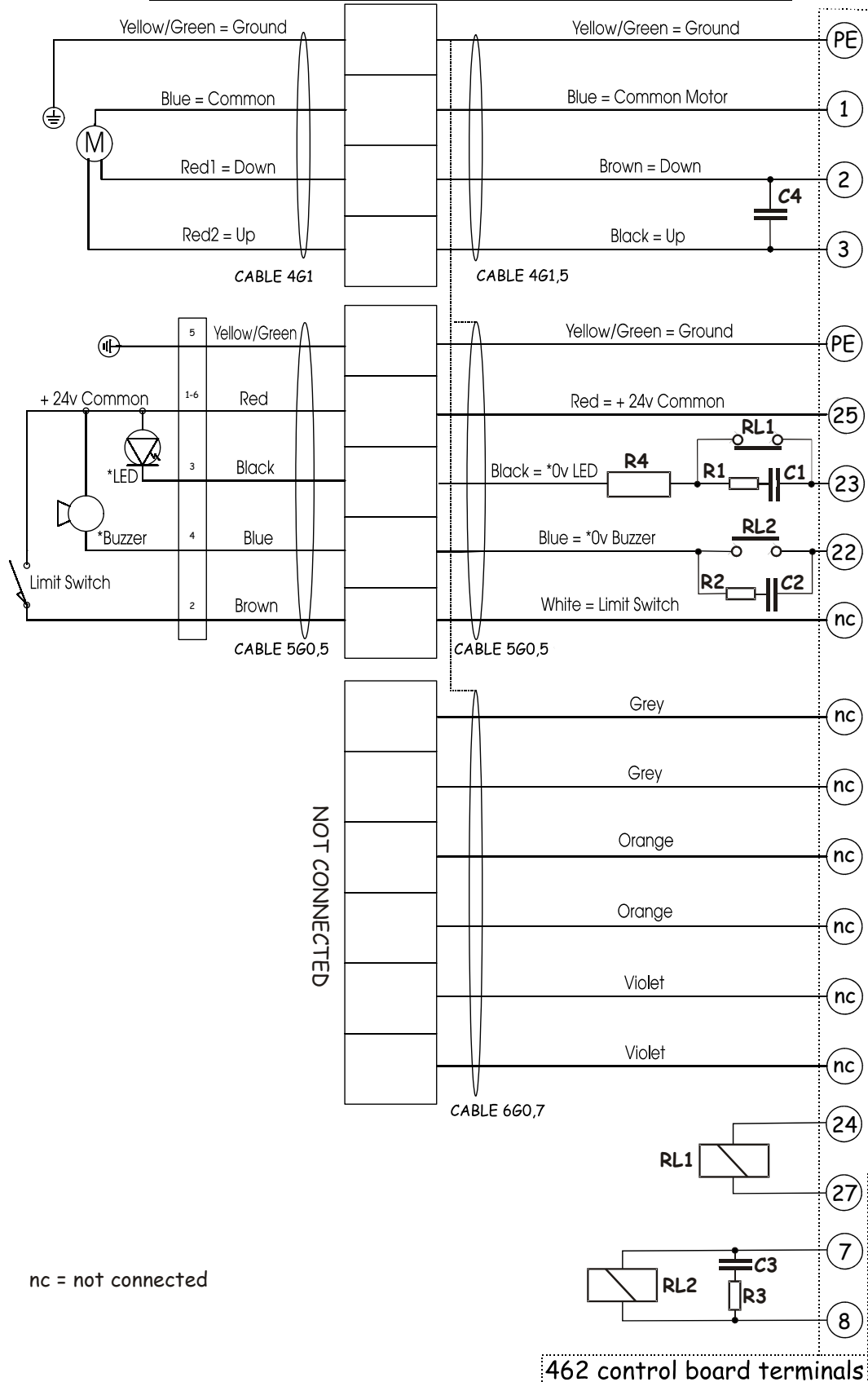

Fig. 6



## CONNECTION TO EQUIPMENT 462DF

To control FAAC City with 462DF, the external components indicated below (not supplied) must be connected, observing the lay-out of fig. 6:

R1 = R2 = R3 = 100ohm 1/4W

R4 = 68ohm 1W

C1 = C2 = C3 = 0,1µF 400Vac

C4 = Capacitor 16 µF 450Vac (supplied standard)

RL1 = Relay (24 Vdc coil) N.C. contact

RL2 = Relay (230Vac coil) N.O. contact

The following registers must be modified on the 462DF equipment:

REG. 14 = hex: 0001XXXX - special indicator light function - (XXXX = the value of these bits depends on other functions)

REG. 46 = 2 - Pre-flashing before raising - (optional)

To connect the accessories and for programming, consult the instructions for 462DF and the Faactotum programmer.

## HOW TO POSITION THE SAFETY INDUCTIVE LOOPS

Any inductive loops on the system must be laid according to specific instructions for the detector. Two laying examples are shown in the following figures.

Fig. 7 shows the laying of a loop providing perimetric protection of the bollard.

Fig. 8 shows the laying of two loops for protecting a very large gate.

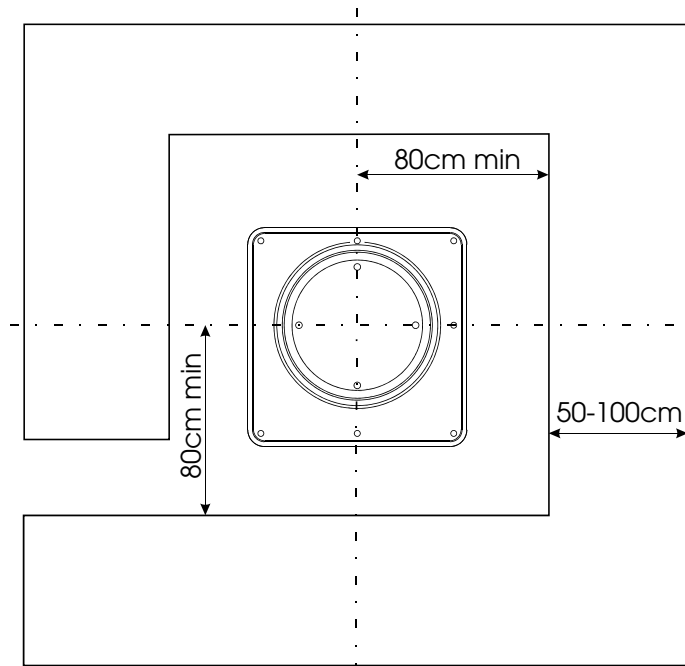
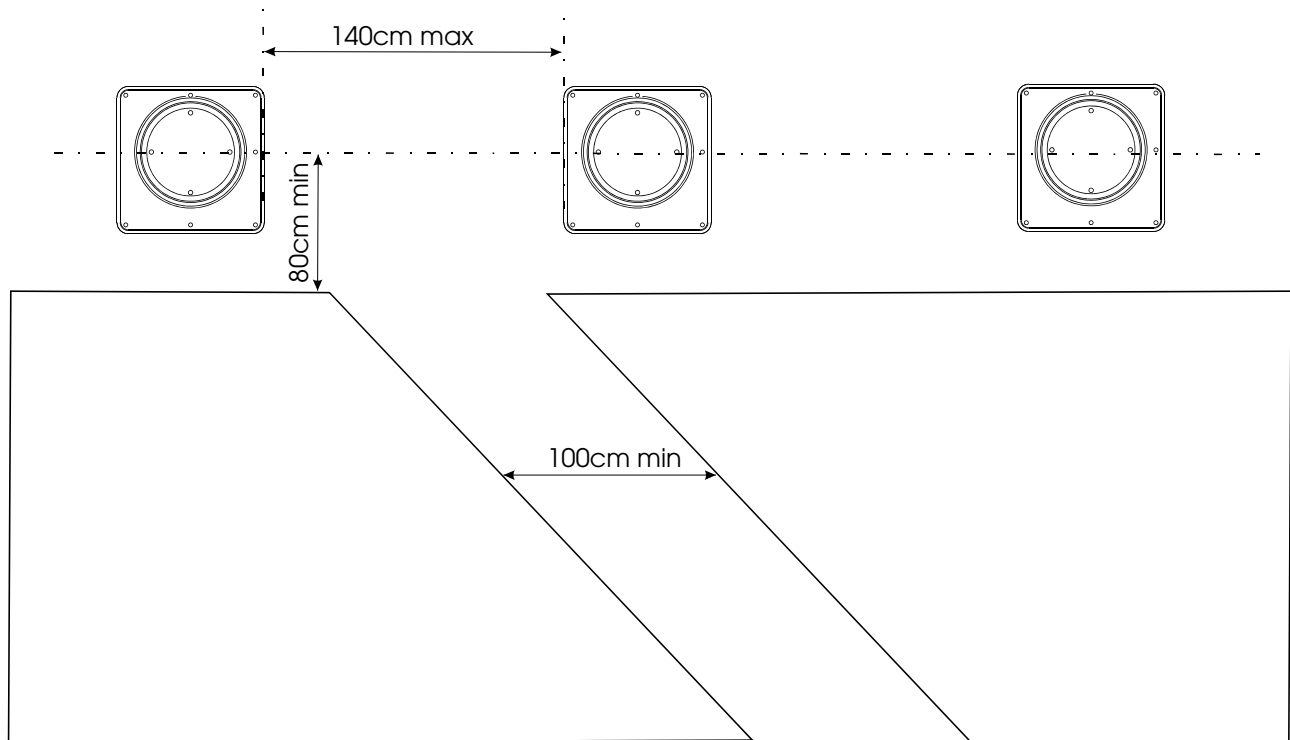

Fig. 7



**Fig. 8**

### **MANUAL LOWERING OPERATION**

In case of an emergency or fault, manually controlled bollard lowering is possible with the following procedure:

- Unfasten the Allen screw located on the base, until you remove it from its seat.
- Press the key under the screw's seat, using the Allen wrench. The bollard descends for as long as you hold the key down.
- When the bollard has been lowered, re-fasten the screw on the base.

The manual lowering device is not supplied on FAAC CITY models with the automatic lowering device.

### **FINAL OPERATIONS**

When you have finished the installation, check the efficiency of the bollard, especially as regards any safety devices which may be installed.



## **STANDARD 6-MONTHLY ROUTINE MAINTENANCE PROCEDURE FOR MOBILE CONCEALED BOLLARD FAAC CITY 275 H600 AND 275 H800:**

This is the standard routine maintenance sequence:

- Clean the pit, exhausting the deposited materials by suction
- Clean the water drainage discharge points on the bottom of the pit
- Clean and lubricate the central sliding guide
- Check (and replace if necessary) the lower contact point seals
- Check and, if necessary, remedy any oil leaks from the motion piston.
- Run a general tightness check of the bollard's screws
- Generally clean the driven cylinder and touch up the paint if necessary
- Check the hydraulic power-pack, top up with oil if necessary, and check the operating pressure setting.
- Check and, if necessary, set the efficiency of the safety pressure switch (40 Kg.)

### **ALSO RUN THE FOLLOWING CHECKS:**

- Check the efficiency of the flashing light incorporated into the bollard head
- Check the efficiency of the inductive safety loops
- Check the efficiency of the radio control receiver
- Visually check the electronic control unit



**FAAC S.p.A.**  
Via Benini, 1  
40069 Zola Predosa (BO) - ITALIA  
Tel.: 051/61724 - Fax: 051/758518  
[www.faac.it](http://www.faac.it)



**Distributor's Stamp:**

The descriptions and illustrations contained in the present manual are not binding. FAAC reserves the right, whilst leaving the main features of the equipments unaltered, to undertake any modifications it holds necessary for either technical or commercial reasons, at any time and without revising the present publication.