

## **SCHEMI DI TAGLIO**

- SCHEMI DI TAGLIO E RELATIVE TABELLE DI  
UTILIZZO ACCESSORI E GUARNIZIONI PER LE  
TIPOLOGIE PRINCIPALI



**CALCOLO INDICATIVO DEL PESO**  
 L (m) X ..... = KG ..... +  
 H (m) X ..... = KG ..... =  
 Peso totale = KG

**SCHEMI DI TAGLIO**      **TAV. 1A**

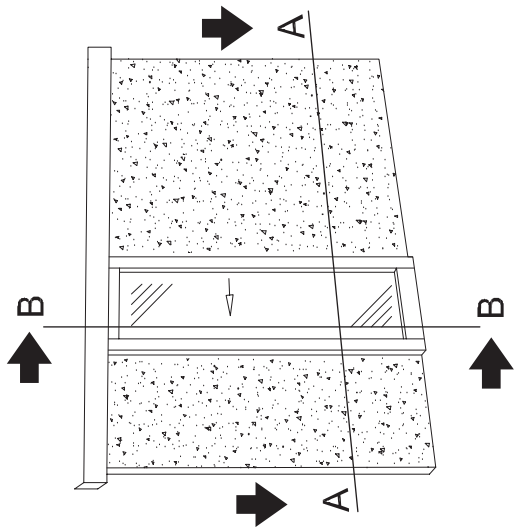
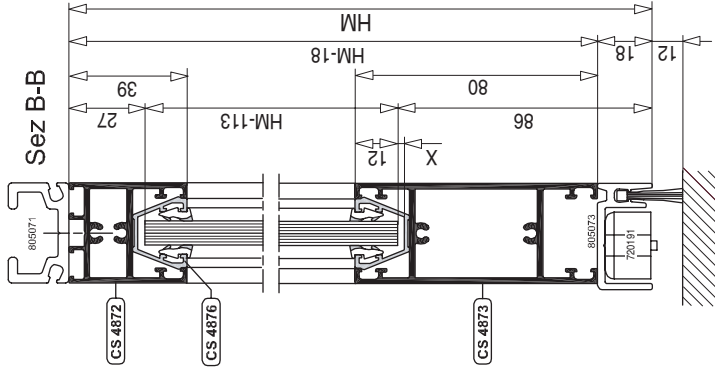

Scala 1:2.5  
 In chiusura

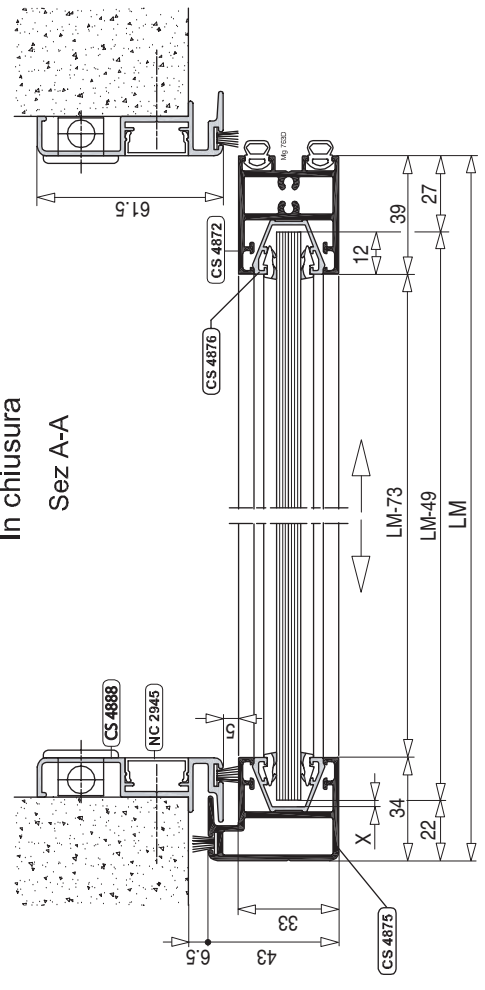

**LIGHT**      **PORTA ANTA SINGOLA**      **SOSTITUISCE TAVOLA DEL**      **DATA**      **01/01/2004**

## ANTA MOBILE SINGOLA LIGHT

SIGLA	PROFILATI	Nr. Pz.	TAGLIO
CS4872	Montante interno anta mobile	1	HM-18
CS4875	Montante esterno anta mobile	1	HM-18
CS4872	Traverso superiore anta mobile	1	LM-73
CS4876	Riduzione orizzontale	2	LM-73
CS4876	Riduzione verticale	2	HM-18
CS4873	Traverso inferiore anta mobile	1	LM-73
CS4888	Accop. muro anta mobile	2	HM+10
NC2945	Carter coprivite di fissaggio	2	HM+10

SIGLA	GUARNIZIONI	Nr. PEZZI	TAGLIO
	Gomma vetro interno	mm	4x(HM-113 + LM-49) +50
MG763D	Gomma battuta	mm	(HM-18)x2
MG205S	Spazzolino	1	HM-18
MG205S	Spazzolino	2	HM+10

**CALCOLO INDICATIVO DEL PESO**  
 L (m) X ..... = KG ..... +  
 H (m) X ..... = KG ..... =  
 Peso totale = KG

**SCHEMI DI TAGLIO**      **TAV. 2A**

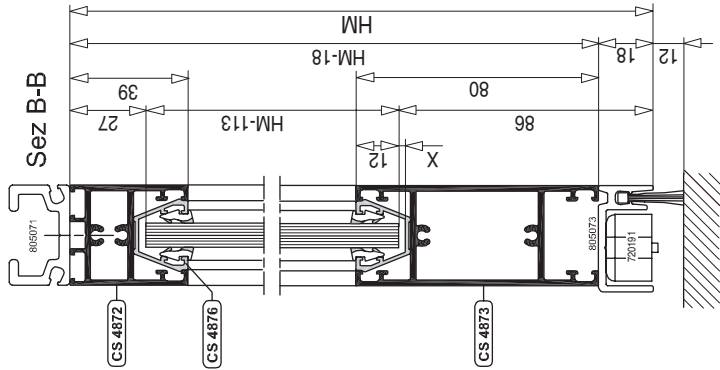
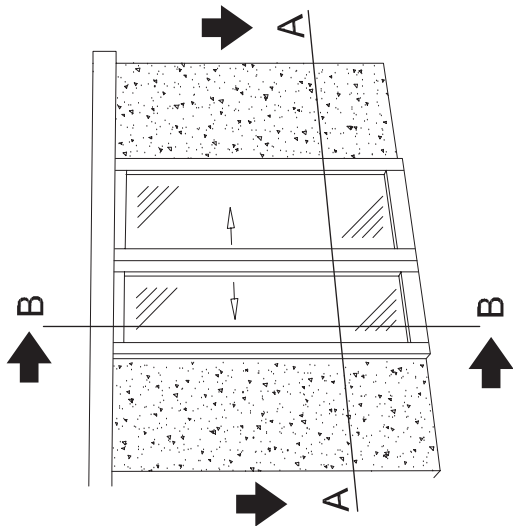

**Scala 1:2.5**  
**In chiusura**

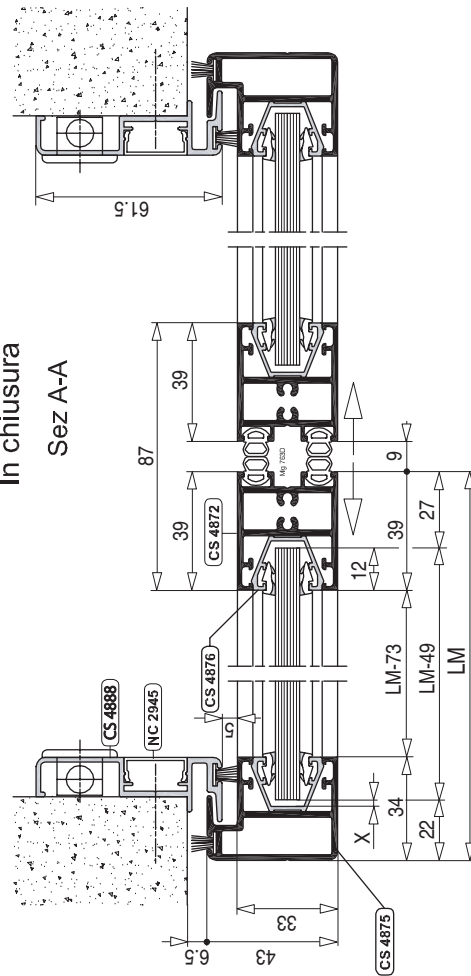

**LIGHT**

**PORTA ANTA DOPPIA**

SOSTITUISCE TAVOLA DEL

DATA

**01/01/2004**

## ANTA MOBILE DOPPIA LIGHT

SIGLA	PROFILATI	Nr. Pz.	TAGLIO
CS4872	Montante interno anta mobile	2	HM-18
CS4875	Montante esterno anta mobile	2	HM-18
CS4872	Traverso superiore anta mobile	2	LM-73
CS4876	Riduzione orizzontale	4	LM-73
CS4876	Riduzione verticale	4	HM-18
CS4873	Traverso inferiore anta mobile	2	LM-73
CS4888	Accop. muro anta mobile	2	HM+10
NC2945	Carter coprivite di fissaggio	2	HM+10

SIGLA	GUARNIZIONI	Nr. PEZZI	TAGLIO
	Gomma vetro interno	mm	8x(HM-113 + LM-49) +50
MG763D	Gomma battuta	mm	(HM-18)x4
MG205S	Spazzolino	2	HM-18
MG205S	Spazzolino	2	HM+10

**CALCOLO INDICATIVO DEL PESO**  
 L (m) X ..... = KG ..... +  
 H (m) X ..... = KG ..... =  
 Peso totale = KG

**SCHEMI DI TAGLIO**  
**TAV. 3A**

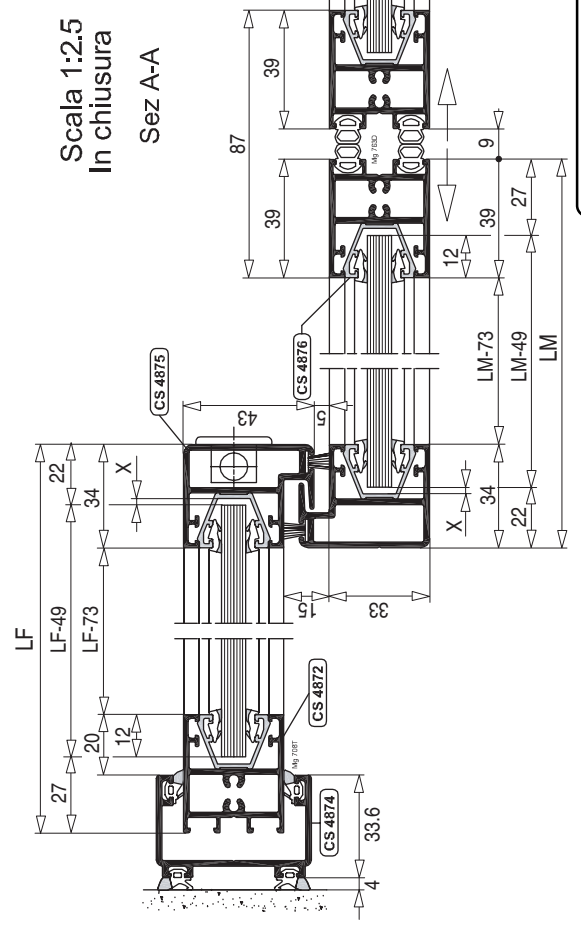
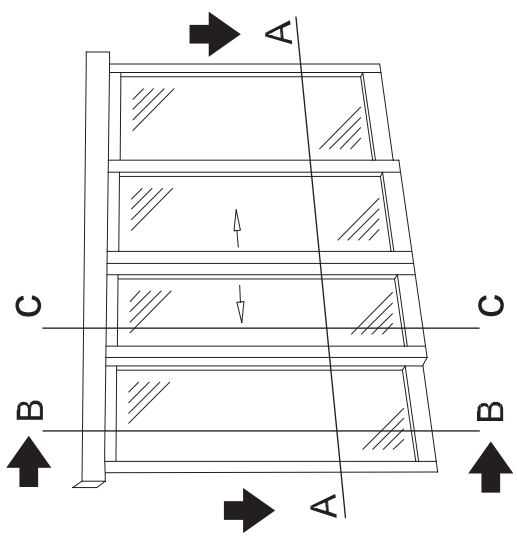
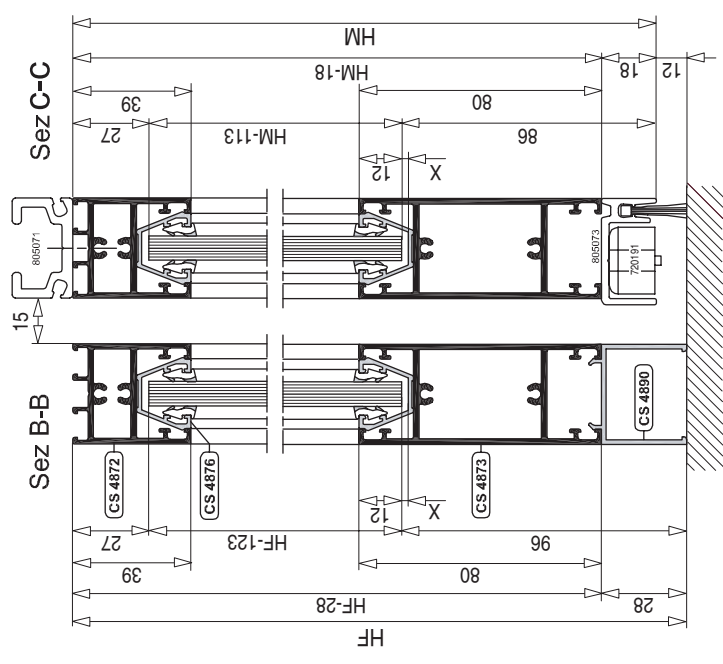

### ANTA FISSA LIGHT

SIGLA	PROFILATI	Nr. Pz.	TAGLIO
CS4872	Montante esterno anta fissa	2	HF-28
CS4875	Montante interno anta fissa	2	HF-28
CS4872	Traverso superiore anta fissa	2	LF-73
CS4876	Riduzione orizzontale	4	LF-73
CS4876	Riduzione verticale	4	HF-28
CS4873	Traverso inferiore anta fissa	2	LF-73
CS4890	Appoggio al suolo	2	LF
CS4874	Fissaggio a muro	2	HF

SIGLA	GUARNIZIONI	Nr. PEZZI	TAGLIO
	Gomma vetro	mm	8x(HF-123 + LF-49) +50
MG708T	Gomma fissag. a muro	mm	HFx8
MG205S	Spazzolino	2	HF-28

### ANTA MOBILE LIGHT

SIGLA	PROFILATI	Nr. Pz.	TAGLIO
CS4872	Montante interno anta mobile	2	HM-18
CS4875	Montante esterno anta mobile	2	HM-18
CS4872	Traverso superiore anta mobile	2	LM-73
CS4876	Riduzione orizzontale	4	LM-73
CS4876	Riduzione verticale	4	HM-18
CS4873	Traverso inferiore anta mobile	2	LM-73

SIGLA	GUARNIZIONI	Nr. PEZZI	TAGLIO
	Gomma vetro interno	mm	8x(HM-113 + LM-49) +50
MG763D	Gomma battuta	mm	(HM-18)x4
MG205S	Spazzolino	2	HM-18



**CALCOLO INDICATIVO DEL PESO**  
 L (m) X ..... = KG ..... +  
 H (m) X ..... = KG ..... =  
 Peso totale = KG

**SCHEMI DI TAGLIO**  
**TAV. 4A**

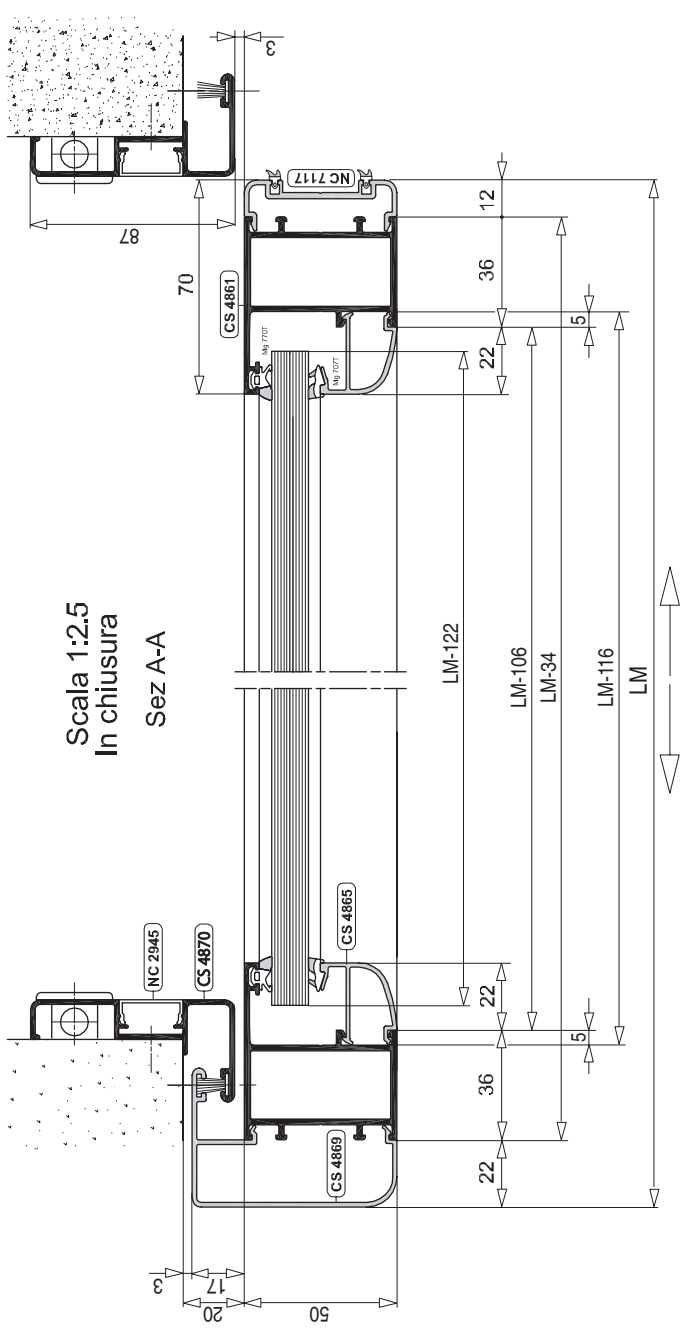
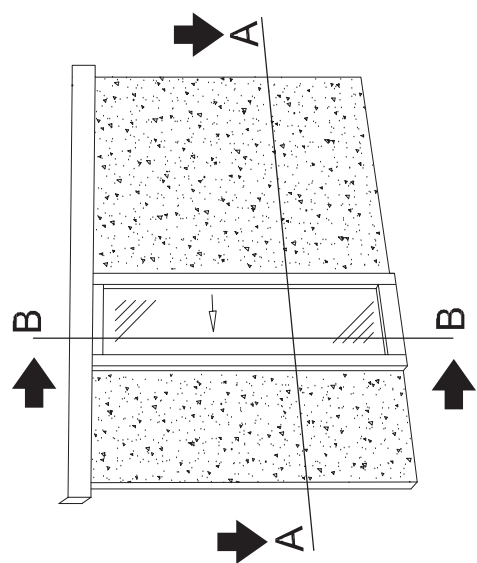
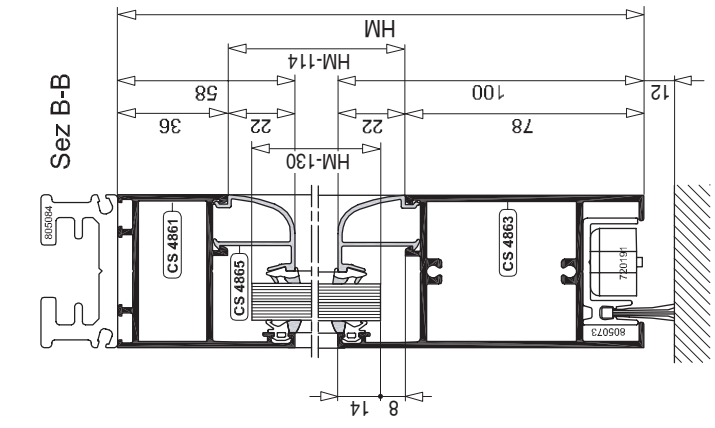

Scala 1:2.5  
 In chiusura

Sez A-A

**HEAVY**      **PORTA ANTA SINGOLA**      **DATA 01/01/2004**

## ANTA MOBILE SINGOLA HEAVY



SIGLA	PROFILATI	Nr. Pz.	TAGLIO
CS4861	Montante destro anta mobile	1	
CS4861	Montante sinistro anta mobile	1	
CS4861	Traverso anta mobile	1	
CS4865	Fermavetro orizz. sup. Sx	1	
CS4865	Fermavetro orizz. sup. Dx	1	
CS4865	Fermavetro orizz. sup. Centr.	1	
CS4865	Fermavetro orizzontale inf.	1	
CS4865	Fermavetro verticale	2	
CS4869	Aletta per montante	1	
NC7117	Carter battuta montante	1	
CS4863	Zoccolo anta mobile	1	
CS4870	Accop. muro anta mobile	2	
NC2945	Carter coprivite di fissaggio	2	

SIGLA	GUARNIZIONI	Nr. PEZZI	TAGLIO
	Gomma vetro interno	mm	2x(HM-130 + LM-122) +50
MG708T	Gomma vetro esterno	mm	2x(HM-130 + LM-122) +50
MG764D	Gomma battuta interna	mm	HMx2
MG205S	Spazzolino	1	HM+10

SIGLA	ACCESSORI	Nr. Pz.	TAGLIO
MA5502	Squadretta	2	
MA5520	Spessore vetro	8	
MA5550	Spine	4	

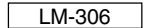
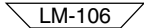

## ANTA MOBILE DOPPIA HEAVY

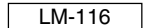
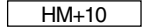
SIGLA	PROFILATI	Nr. Pz.	TAGLIO
CS4861	Montante destro anta mobile	2	
CS4861	Montante sinistro anta mobile	2	
CS4861	Traverso anta mobile	2	
CS4865	Fermavetro orizz. sup. Sx	2	
CS4865	Fermavetro orizz. sup. Dx	2	
CS4865	Fermavetro orizz. sup. Centr.	2	
CS4865	Fermavetro orizzontale inf.	2	
CS4865	Fermavetro verticale	4	
CS4869	Aletta per montante	2	
NC7117	Carter battuta montante	2	
CS4863	Zoccolo anta mobile	2	
CS4870	Accop. muro anta mobile	2	
NC2945	Carter coprivite di fissaggio	2	

SIGLA	GUARNIZIONI	Nr. PEZZI	TAGLIO
	Gomma vetro interno	mm	4x(HM-130 + LM-122) +50
MG708T	Gomma vetro esterno	mm	4x(HM-130 + LM-122) +50
MG764D	Gomma battuta interna	mm	HMx4
MG205S	Spazzolino	2	HM+10

SIGLA	ACCESSORI	Nr. Pz.	TAGLIO
MA5502	Squadretta	4	
MA5520	Spessore vetro	16	
MA5550	Spine	8	







## ANTA FISSA HEAVY

SIGLA	PROFILATI	Nr. Pz.	TAGLIO
CS4861	Montante destro anta fissa	2	
CS4861	Montante sinistro anta fissa	2	
CS4861	Traverso superiore anta fissa	2	
CS4865	Fermavetro orizz. sup. Sx	2	
CS4865	Fermavetro orizz. sup. Dx	2	
CS4865	Fermavetro orizz. sup. Centr.	2	
CS4865	Fermavetro orizzontale inf.	2	
CS4865	Fermavetro verticale	4	
CS4869	Aletta per montante	2	
CS4864	Zoccolo anta fissa	2	
CS4868	Fissaggio a muro	2	

SIGLA	GUARNIZIONI	Nr. PEZZI	TAGLIO
	Gomma vetro interno	mm	4x(HF-140 + LF-110) +50
MG708T	Gomma vetro esterno	mm	4x(HF-140 + LF-110) +50
MG708T	Gomma fissag. a muro	mm	HFx8
MG205S	Spazzolino	2	HF

SIGLA	ACCESSORI	Nr. Pz.	TAGLIO
MA5502	Squadretta	4	
MA5520	Spessore vetro	16	
MA5550	Spine	8	

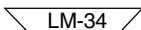
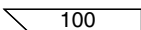
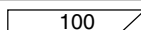
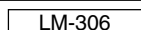
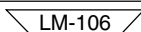
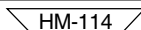
## ANTA MOBILE HEAVY

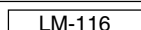
SIGLA	PROFILATI	Nr. Pz.	TAGLIO
CS4861	Montante destro anta mobile	2	
CS4861	Montante sinistro anta mobile	2	
CS4861	Traverso anta mobile	2	
CS4865	Fermavetro orizz. sup. Sx	2	
CS4865	Fermavetro orizz. sup. Dx	2	
CS4865	Fermavetro orizz. sup. Centr.	2	
CS4865	Fermavetro orizzontale inf.	2	
CS4865	Fermavetro verticale	4	
CS4869	Aletta per montante	2	
NC7117	Carter battuta montante	2	
CS4863	Zoccolo anta mobile	2	

SIGLA	GUARNIZIONI	Nr. PEZZI	TAGLIO
	Gomma vetro interno	mm	4x(HM-130 + LM-122) +50
MG708T	Gomma vetro esterno	mm	4x(HM-130 + LM-122) +50
MG764D	Gomma battuta interna	mm	HMx4

SIGLA	ACCESSORI	Nr. Pz.	TAGLIO
MA5502	Squadretta	4	
MA5520	Spessore vetro	16	
MA5550	Spine	8	



## ANTA FISSA HEAVY SFONDAMENTO 2 ANTE

SIGLA	PROFILATI	Nr. Pz.	TAGLIO
CS4887	Montante anta fissa	4	HF
CS4887	Traverso superiore anta fissa	2	LF-108
CS4865	Fermavetro orizz. sup. Sx	2	100
CS4865	Fermavetro orizz. sup. Dx	2	100
CS4865	Fermavetro orizz. sup. Centr.	2	LF-298
CS4865	Fermavetro orizzontale inf.	2	LF-98
CS4865	Fermavetro verticale	4	HF-134
CS4866	Carter per montante	2	HF
CS4864	Zoccolo anta fissa	2	LF-108
CS4868	Fissaggio a muro	2	HF

SIGLA	GUARNIZIONI	Nr. PEZZI	TAGLIO
	Gomma vetro interno	mm	4x(HF-150 + LF-114) +50
MG708T	Gomma vetro esterno	mm	4x(HF-150 + LF-114) +50
MG708T	Gomma fissag. a muro	mm	HFx8

SIGLA	ACCESSORI	Nr. Pz.	TAGLIO
MA5510	Cavalotto	2	
MA5520	Spessore vetro	8	
MA5571	Spine	2	

## ANTA MOBILE HEAVY SFONDAMENTO 2 ANTE

SIGLA	PROFILATI	Nr. Pz.	TAGLIO
NC7023	Montante esterno anta mobile	2	HM
CS4887	Montante interno anta mobile	2	HM
CS4887	Traverso anta mobile	2	LM-136
CS4865	Fermavetro orizz. sup. Sx	2	100
CS4865	Fermavetro orizz. sup. Dx	2	100
CS4865	Fermavetro orizz. sup. Centr.	2	LM-326
CS4865	Fermavetro orizzontale inf.	2	LM-126
CS4865	Fermavetro verticale	4	HM-124
NC7118	Carter per montante	2	HM
NC7117	Carter battuta montante	2	HM
CS4863	Zoccolo anta mobile	2	LM-136
NC5584	Carter per spazzolino	2	HM

SIGLA	GUARNIZIONI	Nr. PEZZI	TAGLIO
	Gomma vetro interno	mm	4x(HM-140 + LM-142) +50
MG708T	Gomma vetro esterno	mm	4x(HM-140 + LM-142) +50
MG764D	Gomma battuta interna	mm	HMx4
MG205S	Spazzolino	2	HM

SIGLA	ACCESSORI	Nr. Pz.	TAGLIO
MA5510	Cavalotto	2	
MA5520	Spessore vetro	8	
MA5571	Spine	2	



**CALCOLO INDICATIVO DEL PESO**  
 L (m) X ..... = KG ..... +  
 H (m) X ..... = KG ..... =  
 Peso totale = KG

**SCHEMI DI TAGLIO**  
**TAV. 8A**

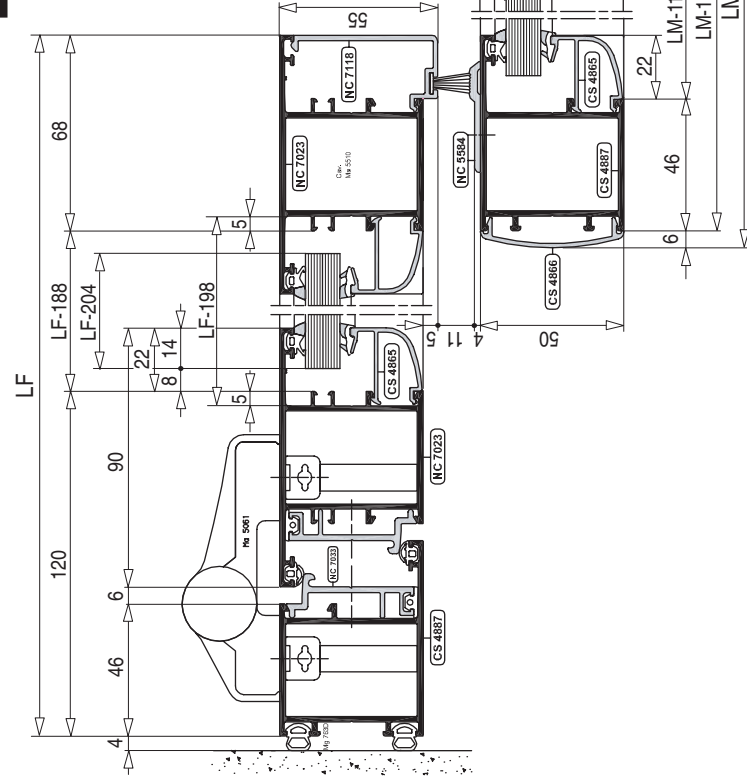
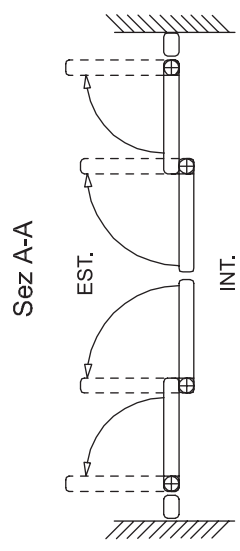
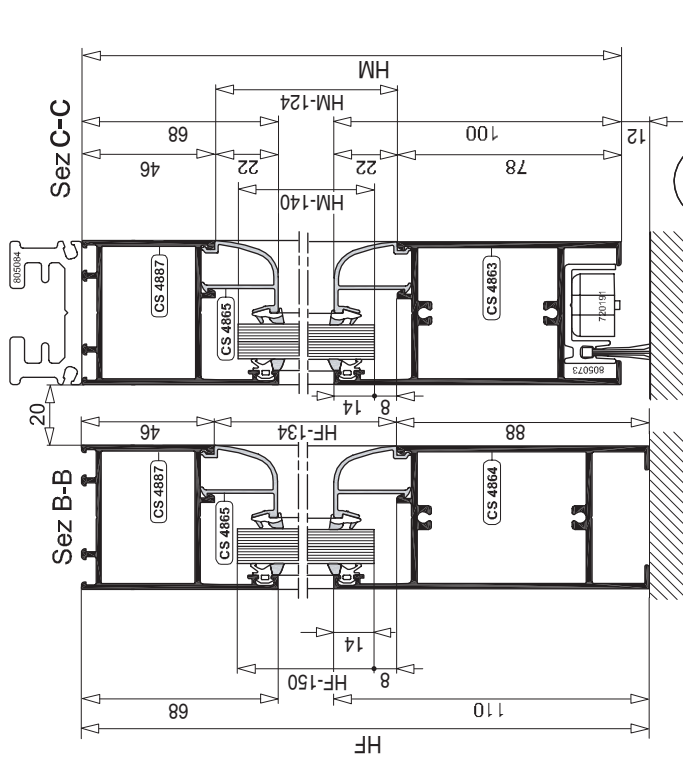
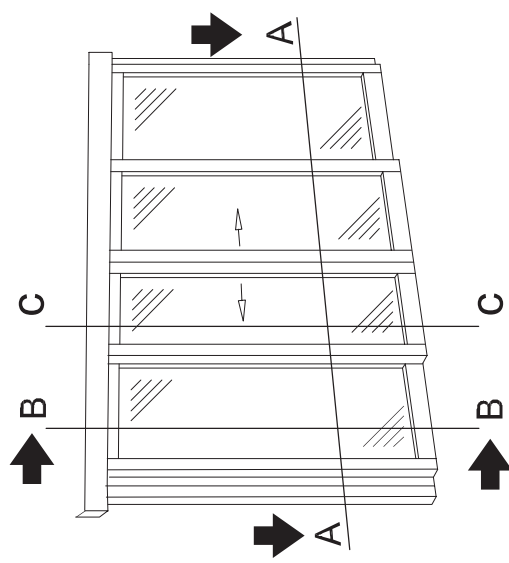

**Scala 1:2.6**  
**In chiusura**  
**Sez A-A**

**FAAC**

## ANTA FISSA HEAVY SFONDAMENTO 4 ANTE

SIGLA	PROFILATI	Nr. Pz.	TAGLIO
NC7023	Montante anta fissa	4	HF
CS4887	Traverso superiore anta fissa	2	LF-198
CS4865	Fermavetro orizz. sup. Sx	2	100
CS4865	Fermavetro orizz. sup. Dx	2	100
CS4865	Fermavetro orizz. sup. Centr.	2	LF-388
CS4865	Fermavetro orizzontale inf.	2	LF-188
CS4865	Fermavetro verticale	4	HF-134
NC7118	Carter per montante	2	HF
CS4864	Zoccolo anta fissa	2	LF-198
CS4887	Fissaggio a muro	2	HF
NC7033	Carter interno	4	HF

SIGLA	GUARNIZIONI	Nr. PEZZI	TAGLIO
	Gomma vetro interno	mm	4x(HF-150 + LF-204) +50
MG708T	Gomma vetro esterno	mm	4x(HF-150 + LF-204) +50
MG763D	Gomma accop. telai	mm	HFx4
MG205S	Spazzolino	2	HF
MG475D	Non fornito	mm	HFx4
MG766D	Non fornito	mm	HFx4

SIGLA	ACCESSORI	Nr. Pz.	TAGLIO
MA5510	Cavallotto	2	
MA5520	Spessore vetro	8	
MA5571	Spine	2	
MA5061A	Cerniera	2	
MA5071	Vite	4	

## ANTA MOBILE HEAVY SFONDAMENTO 4 ANTE

SIGLA	PROFILATI	Nr. Pz.	TAGLIO
CS4887	Montante anta mobile	4	HM
CS4887	Traverso anta mobile	2	LM-120
CS4865	Fermavetro orizz. sup. Sx	2	100
CS4865	Fermavetro orizz. sup. Dx	2	100
CS4865	Fermavetro orizz. sup. Centr.	2	LM-310
CS4865	Fermavetro orizzontale inf.	2	LM-110
CS4865	Fermavetro verticale	4	HM-124
CS4866	Carter per montante	2	HM
NC7117	Carter battuta montante	2	HM
CS4863	Zoccolo anta mobile	2	LM-120
NC5584	Carter per spazzolino	2	HM

SIGLA	GUARNIZIONI	Nr. PEZZI	TAGLIO
	Gomma vetro interno	mm	4x(HM-140 + LM-126) +50
MG708T	Gomma vetro esterno	mm	4x(HM-140 + LM-126) +50
MG764D	Gomma battuta interna	mm	HMx4

SIGLA	ACCESSORI	Nr. Pz.	TAGLIO
MA5510	Cavallotto	2	
MA5520	Spessore vetro	8	
MA5571	Spine	2	