

EC MACHINE DIRECTIVE COMPLIANCE DECLARATION

(DIRECTIVE 89/392 EEC, APPENDIX II, PART B)

Manufacturer: FAAC S.p.A.

Address: Via Benini, 1
40069 - Zola Predosa
BOLOGNA - ITALY

Hereby declares that: the 961 B-E automation system

- is intended to be incorporated into machinery, or to be assembled with other machinery to constitute machinery in compliance with the requirements of Directive 89/392 EEC, and subsequent amendments 91/368 EEC, 93/44 EEC and 93/68 EEC;
- complies with the essential safety requirements in the following EEC Directives:

73/23 EEC and subsequent amendment 93/68 EEC.
89/336 EEC and subsequent amendments 92/31 EEC and 93/68 EEC.

and furthermore declares that unit must not be put into service until the machinery into which it is incorporated or of which it is a component has been identified and declared to be in conformity with the provisions of Directive 89/392 EEC and subsequent amendments enacted by the national implementing legislation.

Bologna, 1 January 1997

Managing
Director

A. Bassi

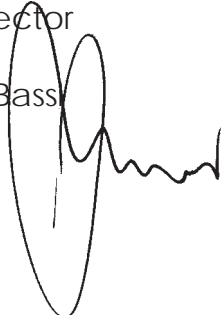
A handwritten signature in black ink, consisting of a large, stylized loop followed by a series of smaller, connected strokes.

IMPORTANT NOTICE FOR THE INSTALLER

GENERAL SAFETY REGULATIONS

- 1) **WARNING! FAAC strongly recommends to follow these instructions literally for the safety of persons. Improper installation or misuse of the product will cause very serious damages to persons.**
- 2) Packaging material (plastic, polystyrene etc.) is a potential hazard and must be kept out of reach of children.
- 3) Read the instructions carefully before installing the product.
- 4) Keep these instructions for future reference.
- 5) This product has been designed and manufactured only for the use stated in this manual. Any other use not expressly set forth will affect the reliability of the product and/or could be source of hazard.
- 6) FAAC S.p.A. cannot be held responsible for any damage caused by improper use or different from the use for which the automation system is destined to.
- 7) Do not use this device in areas subject to explosion: the presence of flammable gas or fumes is a serious hazard.
- 8) Mechanical constructive elements must comply with CEN pr EN 12650-1 and CEN pr EN 12650-2 standards.
Countries outside the EC shall follow the regulations above besides their national normative references in order to offer the utmost safety.
- 9) FAAC cannot be held responsible for failure to observe technical standards in the construction of gates and doors, or for any deformation of the gates which may occur during use.
- 10) Before carrying out any operations, turn off the system's main switch.
- 11) An omnipower switch shall be provided for the installation with an opening distance of the contacts of 3 mm or more. Alternatively, use a 6A thermomagnetic breaker with multi-pole switching.
- 12) Ensure that there is a differential switch up-line of the electrical system, with a trip threshold of 0.03A.
- 13) Check that the earthing plant is in perfect condition and connect it to the metallic parts. Also earth the yellow/green wire of the operator.
- 14) The automation is fitted with an anti-crush safety system that is a torque control device. In any case, further safety devices shall be installed.
- 15) The safety devices (e.g. photocells, safety edges, etc.) protect areas where there is a mechanical movement hazard, e.g. crushing, entrapment and cutting.
- 16) Each installation must be fitted with at least one warning plate suitably fixed to the gate, besides the safety devices as per point 15. above.
- 17) FAAC cannot be held responsible regarding safety and correct functioning of the automation in the event that parts other than FAAC original parts are used.
- 18) Use only FAAC original spare parts for maintenance operations.
- 19) Do not carry out any modifications to automation components.
- 20) The installer must supply all information regarding manual operation of the system in the event of an emergency and provide the end-user with the leaflet attached to the product.
- 21) Keep out of persons when the product is in operation.
- 22) Keep out of reach of children the remote radio controls and any control devices. The automation could be operated unintentionally.
- 23) The end-user must avoid any attempt to repair or adjust the automation personally. These operations must be carried out exclusively by qualified personnel.
- 24) **What is not explicitly stated in these instructions is not permitted.**

FAAC 961 B-E

The 961 B-E automatic unit for swing doors is a one-piece unit consisting of an electromechanical device that allows door opening to be controlled by means of a driving arm. The door is re-closed by a spring system.

The operator can be installed either on the lintel or on the door structure itself.

The stainless steel protective casing houses the electronic control unit used to program and control the operation of the system.

In the event of a power failure the door can be pushed (or pulled) open manually.

1. DESCRIPTION AND TECHNICAL CHARACTERISTICS

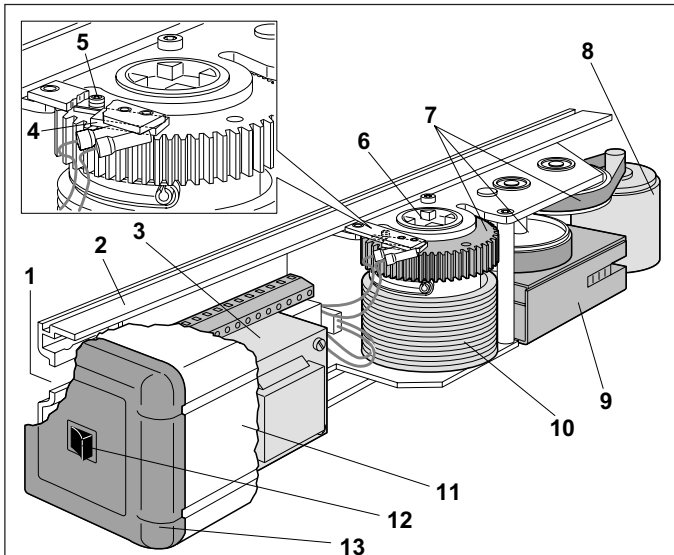

Fig. 1

- ① Cable hole
- ② Support profile
- ③ 960 MP electronic control unit
- ④ Position monitoring microswitch
- ⑤ Spring loading adjustment screw
- ⑥ Transmission shaft
- ⑦ Drive system
- ⑧ DC motor
- ⑨ 961 B-E programming unit
- ⑩ Closing spring
- ⑪ Protective casing
- ⑫ Operating function switch
- ⑬ End cover (2)

Table 1: Technical specifications of 961 B-E Operator

Power supply	230 Vac (+6 -10%) - 50 (60) Hz
Absorbed power	100 W
Current drawn	0.5 A
Electric motor	24 Vdc with encoder
Dimensions	530 x 100 x 104 (length x height x depth)
Weight	10 kg
Ambient temperature	-15 +70 °C
Housing protection	IP 23
Dimensions and max. weight of leaf	see Table 3 (section 1.1)
Duty cycle	continuous
Operation in event of power failure	Manual push/pull opening - Spring closure
Configuration of driving arms	<ul style="list-style-type: none"> • pushing articulated arm (version for jamb depth 0-125 mm) • pushing articulated arm - (version for jamb depth 126-250 mm) • pulling articulated arm • sliding arm
Anti-crushing device	standard
Opening angle	70-95°
Opening time	3.5 - 10 s (adjustable)
Closing time	6 - 13 s (adjustable)

Table 2: Technical specifications of 960MP Electronic Control Unit + 961 B-E Programming unit

Power supply	230 Vac (+6 -10%) - 50 (60) Hz
Accessories power supply	24 Vdc / 500 mA max.
Electric lock power supply (N.O./N.C.)	24 Vdc / 0.5 A max.
Standard operating functions (switch)	Open / Automatic / Manual (Night)
Adjustable functions (trimmer)	Opening speed - Closing speed Pulling force - Pause time
Selectable functions (microswitches)	Overclosing stroke Standard/non-standard initialisation procedure Push and Go - Function switch (pos. "0")
Terminal strip outputs	Door open/closed signal - Malfunction alarm signal - 24 Vdc electric lock power supply (N.O./N.C.) - 24 Vdc accessories power supply - Presence signal (gong) - PC connection signals - "Interlock" signals - "Double leaf door" signals
Terminal strip inputs	Function switch/CODIS (optional) - Internal / external / emergency / STOP safety device / CLOSURE safety device

1.1 APPLICATION LIMITS

Important: To ensure correct application of the FAAC 961 B-E unit the weight of the door must not exceed the value given in Table 3 corresponding to its length.

The maximum length of the leaf is 1400 mm.

The values of maximum weight vary according to the driving arm used.

For each driving arm there is also a different maximum value for the depth of the doorpost (Table 4) beyond which it is not possible to install the system correctly.

Table 3: Application limits of 961 B-E automatic unit

Length of leaf (mm)	Max. weight of leaf (kg)	Max. weight of leaf (kg)	Max. weight of leaf (kg)
	Pushing articulated arm	Pulling articulated arm	Sliding arm
700	367	286	-
750	320	249	-
800	281	219	-
850	249	194	194
900	222	173	173
950	199	155	155
1000	180	140	140
1050	163	127	127
1100	149	116	116
1150	136	106	106
1200	125	97	97
1250	115	90	90
1300	107	83	83
1350	99	77	77
1400	92	71	71

Table 4: Max. depth of doorpost

mm	Pushing articulated arm (Var. 01)	Pushing articulated arm (Var. 02)	Pulling articulated arm	Sliding arm
		0 - 125	126 - 250	0 - 160

2. ELECTRICAL SETUP (fig. 2a Standard system)

- ① 961 B-E operator
- ② Microwave radar / Passive infrared sensor
- ③ T20E external key-switch (KEY command)
- ④ Emergency Closing/Opening pushbutton
- ⑤ CODIS programming unit (optional)
- ⑥ CODIS inhibition switch (optional)
- ⑦ 24 Vdc electric lock
- ⑧ Junction box

If the operator is installed on the door, make the electrical connections using a junction box and suitable commercially available pipes/unions (fig. 2b).

- N.B.:**
- 1) For installation of electrical cables use suitable rigid or flexible piping.
 - 2) Always keep the low voltage accessory connection cables separate from the 230 V power cables. Use separate sheaths to avoid any interference.

3. INSTALLATION

3.1 PRELIMINARY CHECKS

To ensure correct operation of the automatic unit the structure of the existing door must meet the following requirements:

- length and weight as specified in Table 3 (section 1.1);
- max. doorpost depth as specified in Table 4;
- robust and rigid structure of the leaf;
- good condition of the existing hinges;
- smooth, uniform movement of the leaf with no abnormal friction at any point of its travel;
- "neutral" position of the door during its entire travel. If the door tends to close or open, check the alignment of the hinges.
- Presence of mechanical end stops.

3.2 MOUNTING THE OPERATOR

- 1) Remove the protective casing (fig. 3) and the end covers (fig. 4) from the operator.

Warning: Before removing the end cover with the function switch, remove the connector joining the switch to the 960MP electronic control unit.

- 2) As regards the mounting position of the operator (on the lintel or on the door) and the type of arm to use (pushing, pulling or sliding), refer to the relevant mounting table and drill the holes required to mount the operator and the pulling arm.

N.B.: The two intermediate operator fixing holes are not in a central position (see mounting tables). The holes are offset in order to ensure that the operator is mounted with the correct direction of rotation of the mechanism.

The mounting tables are the following:

Table A: LINTEL MOUNTING (PUSHING ARTICULATED ARM)
Outward opening

Table B: DOOR MOUNTING (PUSHING ARTICULATED ARM)
Inward opening

Table C: LINTEL MOUNTING (PULLING ARTICULATED ARM)
Inward opening

Table D: LINTEL MOUNTING (SLIDING ARM) Inward opening

- 3) Mount the operator using the six M6 screws and washers provided.

Warning:

- The structure of the lintel (or the door) at the operator mounting position must not exhibit any significant deformation.
- The operator must be mounted parallel to the floor.

N.B.: If the sliding arm is to be used, the driving arm must be mounted before the operator is fixed on the lintel (see section 3.3.3.).

3.3 MOUNTING THE DRIVING ARMS

3.3.1 MOUNTING THE PUSHING ARTICULATED ARM (fig. 5)

- 1) Close the door.
- 2) Free arms (1) and (2) by pulling apart the coupling (3) manually as shown in fig. 5.
- 3) Fit arm (1) on the operator transmission shaft by means of the extension and the screw (4) provided (fig. 5). The arm must be mounted perpendicular to the closed door.

N.B.: If a greater distance between the operator and the arm is required, use the higher extensions available as accessories (see Table A/B).

- 4) Mount plate (5) of arm (2) on the door or the lintel using the two M6 screws and the washers provided (fig. 5). The installation distances are given in Table A/B.
- 5) Slacken the fixing screw (6) and assemble the two arms by means of coupling (3) (fig. 5).
- 6) Turn arm (1) until arm (2) is perpendicular to the closed door or the lintel as shown in fig. 5 (a-b), sliding the spacer (7) along arm (2).
- 7) Tighten the fixing screw (6) between the two arms. The length of arm (2) is given in the relevant mounting tables. If necessary, cut off the section of the arm extending beyond the articulation and then cover the ends using the caps provided (fig. 5).
- 8) Check manually that the door is free to open and close fully and that it comes to rest against the mechanical end stops. If the door does not close correctly, adjust the return spring as described in section 10.

Important: The two driving arms must never touch.

N.B.: For 90° opening it is not necessary to install the mechanical opening stop (microswitch no. 2 in OFF position - see section 5).

3.3.2 MOUNTING THE PULLING ARTICULATED ARM (fig. 6)

- 1) Close the door.
- 2) Free arms (1) and (2) by pulling apart the coupling (3) manually as shown in fig. 6.
- 3) Fit arm (1) on the operator transmission shaft by means of the extension and the screw (5) provided (fig. 6). The arm must be mounted parallel to the closed door.

N.B.: If a greater distance between the operator and the arm is required, use the higher extensions available as accessories (see Table C).

- 4) Mount plate (6) of arm (4) on the door using the two M6 screws and the washers provided (fig. 6). The installation distances are given in Table C.
- 5) Slacken the screws (7) and slide the attachment (8) along arm (4) so as to position it at distance D given in Table C. Having done this, tighten screws (7).
- 6) Slacken screw (9) and assemble the two arms using the coupling (3) (fig. 6).
- 7) Turn arm (1) as shown in fig. 6(a) until it reaches a distance of 83 mm from the lintel. Having done this, tighten the fixing screw (9) between the two arms. If necessary, cut off the section of the arm extending beyond the articulation and then cover the ends using the caps provided (fig. 6).
- 8) Check manually that the door is free to open and close fully and that it comes to rest against the mechanical end stops. If the door does not close correctly, adjust the return spring as described in section 10.

Important: The driving arms must never touch.

3.3.3 MOUNTING THE SLIDING ARM (fig. 7)

- 1) Mount arm (1) on the operator transmission shaft by means of the extension and the screw (2) provided (fig. 7). The arm must be fitted pointing 45° outwards as shown in fig. 7(a).

N.B.: If a larger distance is required between the operator and the arm use the higher extensions available as accessories (see Table D).

Warning: Mount arm (1) on the transmission shaft before fitting

the operator on the lintel (fig. 7).

- 2) Insert the roller (3) inside the sliding guide (4) (fig. 7).
- 3) Pull arm (1) inwards manually as shown in fig. 7(b) and secure the sliding guide (4) by means of two M6 screws on the closed door as shown in Table D.
- 4) Check manually that the door is free to open and close fully and comes to rest against the mechanical end stops. If the door does not close correctly, adjust the return spring as described in section 10.

4. START-UP

- 1) Make the electrical connections to the 960 MP electronic control unit as described in section 6.
To gain access to the control unit, pass the cables through the special conduit (fig. 1 - ref. 1) as shown in fig. 8.
- 2) Fit the two end covers and connect up the function switch. The end cover with the switch may be fitted on the right or the left. For cable routing refer to fig. 8.
- 3) Turn the operating function switch (fig. 1 - ref. 12) to position I (**AUTOMATIC** logic).
- 4) Check that the programming unit microswitches (fig. 10) are all in the **OFF** position.

Important: When mounting the "pulling articulated" or "sliding" arms or for opening angles greater than 90°, turn **microswitch no. 2 to ON** before connecting power to the system.

- 5) Close the door.
- 6) Power up the operator. Powering is signalled by an acoustic signal from a buzzer.
- 7) Check that the 5V LED on the programming unit (fig. 9) lights up.

- 8) At the end of the initialisation procedure, check the status of the signalling LEDs on the programming unit as shown in Table 5.

Table 5: Operation of status LEDs

LED	ON	OFF
5 V	logic powered	logic not powered
OK	command active	command inactive
YES	safety devices active	safety devices inactive

N.B.: The status of the LEDs with the door closed at rest is shown in bold type.

4.1. INITIALISATION PROCEDURE

As soon as the system is powered up, it runs an initialisation procedure which includes setting the following parameters:

- measuring the mass of the door;
- determining the end stop positions;
- determining the point at which the STOP safety device intervenes (see section 6).

The door opens at low speed, then closes half way before switching back to opening.

Subsequent closure is performed by the return spring. The initialisation procedure is indicated by an intermittent acoustic signal (frequency 1 sec) emitted by a buzzer on the programming unit (table 6).

The process may be inhibited due to:

- function switch in the 0 (MANUAL) position;
- incorrect connection of the accessories (electric lock, control/safety devices);
- incorrect positioning of the programming unit microswitches.

N.B.: To repeat the initialisation procedure **hold down the RESET button** (fig. 11 - ref. 4) for more than 4 seconds.

5. 961 B-E PROGRAMMING UNIT

5.1 LAYOUT AND DESCRIPTION

- | | |
|--|---|
| ① Signalling LEDs (see Table 5) | with 960 MP electronic control unit |
| ② Signalling buzzer (see section 5.4.) | ⑥ Encoder |
| ③ Adjusting trimmer | ⑦ Connector (2 pole) for connection with 960 MP electronic control unit |
| ④ Programming microswitches | |
| ⑤ Connector (16 pole) for connection | |

5.2. SETTING THE ADJUSTING TRIMMERS

The programming unit features trimmers (fig. 9 - ref. 3) which regulate the following parameters:

Trimmer Vo to set the opening speed.
Setting 30 ÷ 100% of the initialisation value.
Standard setting 50%.

Trimmer Vc to set the closing speed.
Setting 30 ÷ 100% of the initialisation value.
Standard setting 50%.

N.B.: The speed initialisation values depend on the dimensions and the mass of the door.

Trimmer To to set the pause time (AUTOMATIC logic).
Setting from 1 to 30 seconds.
Standard setting 3 seconds.

Trimmer Fm to set the pulling force of the operator.
Setting 60 ÷ 100% of maximum value.
Standard setting 100%.

Turn the trimmers clockwise to increase the values of the settings.

Turn the trimmers anticlockwise to reduce the values of the settings.

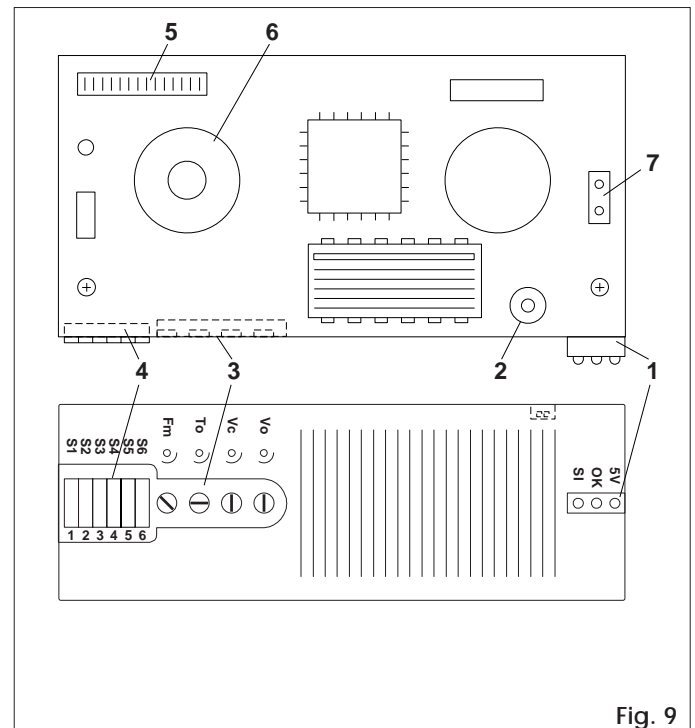

Fig. 9

5.3. PROGRAMMING THE MICROSWITCHES (fig. 10)

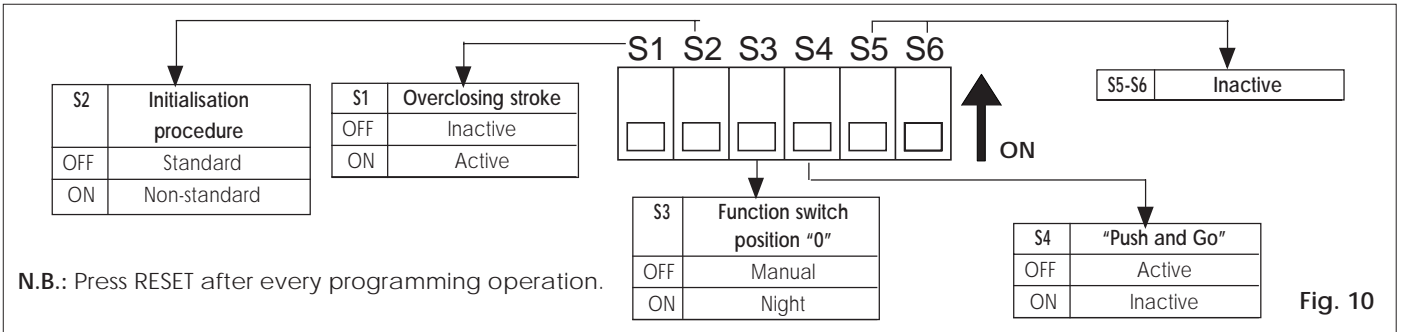

Fig. 10

The programming unit has a series of microswitches which allow the functions shown in fig. 10 to be selected. The system is supplied with all the microswitches in the OFF position.

5.3.1. OVERCLOSING STROKE

This function enables the closed position force to be increased by further loading the transmission system after the door has reached the mechanical closure end stop. It is advisable to use this function if the door is subject to pressure caused by atmospheric agents (e.g. gusts of wind) when closed.

5.3.2. INITIALISATION PROCEDURE

If pulling articulated arms or sliding arms are mounted or in the event of opening angles of more than 90°, the NON-STANDARD process must be selected. In this case an external mechanical stop must always be provided.

5.3.3. FUNCTION SWITCH ("0" POSITION)

This function allows the operating function to be selected with the switch in the "0" position (see section 7).

5.3.4. PUSH AND GO

When activated, this function enables the opening command to be given by pushing the closed door manually. It is sufficient to give the door an initial push in the opening direction.

5.4. SIGNALLING BUZZER

The programming unit incorporates a buzzer which emits sequences of acoustic signals corresponding to different statuses of the system. The statuses that have occurred and their identification sequence can be seen in Table 6.

Table 6: Acoustic signals

STATUS SIGNALLED	ACOUSTIC SEQUENCE
Connection to mains power supply	
Initialisation procedure	
Alarm: Error "A"	
Alarm: Error "B"	

The indication of error A does not inhibit the operation of the automation unit. The indication of error B inhibits the operation of the automation unit until the fault is eliminated. Table 8 (paragraph 8.4) contains a list of the malfunction conditions indicated by the system. To identify the fault, connect the CODIS external programming unit (optional).

6. 960 MP ELECTRONIC CONTROL UNIT

Warning: Always disconnect the electric power supply before carrying out any work on the control unit (connection, maintenance).

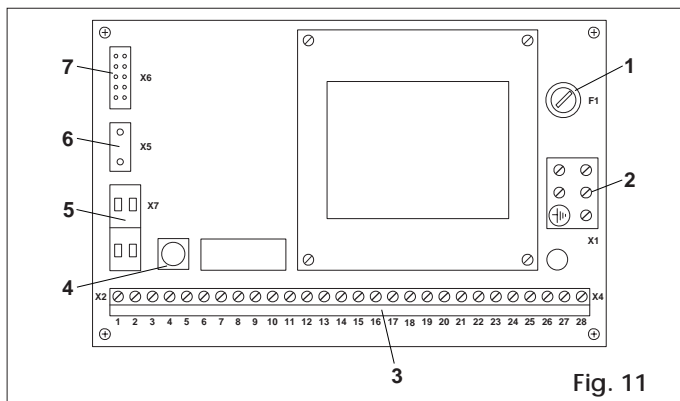

Fig. 11

- ① Fuse F1 1AT/230Vac - 5x20
- ② Terminal strip X1 (230 V) - fig. 12
- ③ Low voltage terminal strip X2 / X4

Description of the terminal strip

- 1. - 2. - 3. Connection of function switch (fig. 1 - ref. 12) as shown in fig. 13.
- Connection of CODIS programming unit (optional) as shown in fig. 14.
- Use a 2 x 0.5 mm² screened cable (bus communication)

for the connection. The screening must be fixed underneath the special screws (fig. 14 - ref. 1).

Important: The maximum permissible length of the connection cable is 50 m.

To inhibit operation of the CODIS, interrupt the jumper between terminals 3 and 4 and install a switch (fig. 14 - ref. 2).

Warning: If the CODIS is used on a continuous basis, function no. 7 must be activated at level III (see section 8).

Activation of input 3 (fig. 14) enables the NIGHT or ONE-WAY operating functions to be given priority over the function selected on the CODIS unit. To select the priority function, program the CODIS suitably at level III (function no. 2 - see section 8.3). The input can be activated by means of a timer.

- 4. **Electric lock - Common**
- 5. **Electric lock - N.C. contact (max. capacity 0.5 A/24 V) (fig. 15).** The output is suitable for commanding a magnetic closure system. If no power is supplied, the electric lock is not active. In the NIGHT function the electric lock is powered and hence active. In the event of an opening command (internal command or EMERGENCY OPENING), the power supply to the electric lock is temporarily cut off to allow the door to be opened.
- 6. **Electric lock - N.O. contact (max. capacity 0.5 A/24 V) (fig. 16).** If no power is supplied the electric lock is active and therefore guarantees-CLOSING mechanical locking. In the NIGHT function the electric lock is active even if no power is supplied. In the event of an opening command (internal command or EMERGENCY OPENING), the electric lock is temporarily powered to enable the door to be opened. In this case a reverse stroke command is also

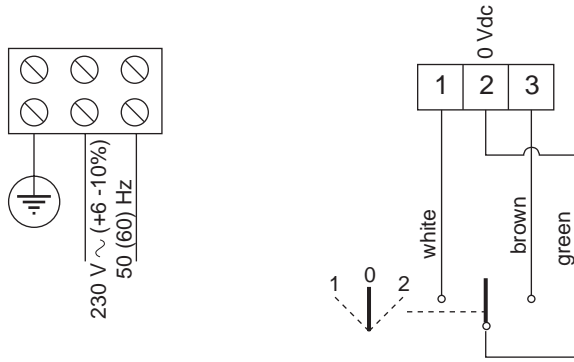

Fig. 12

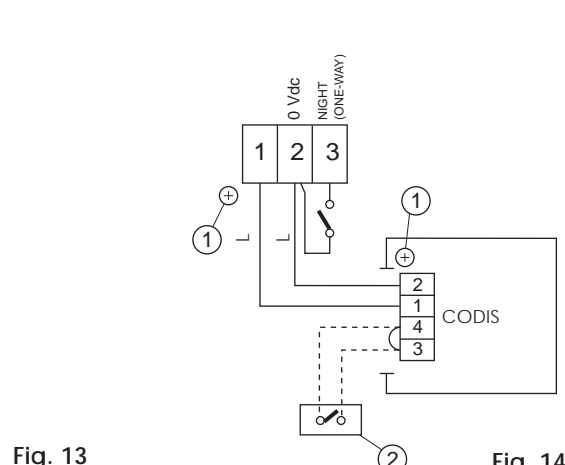

Fig. 13

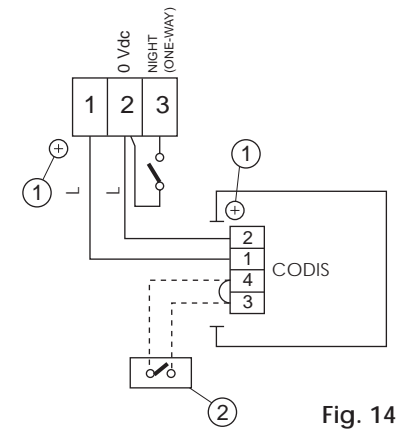

Fig. 14

L = screened cable 2 x 0.5 mm 2; 50 m max.

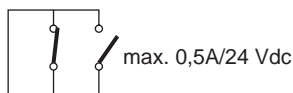

Fig. 15

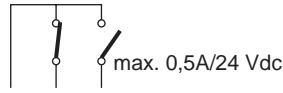

Fig. 16

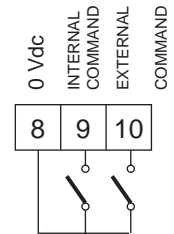
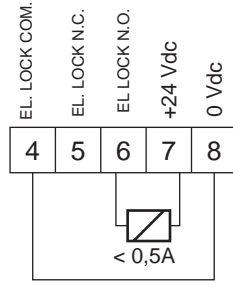
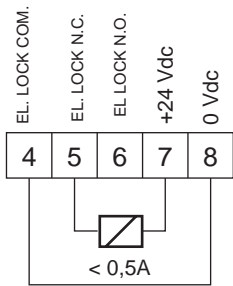

Fig. 17

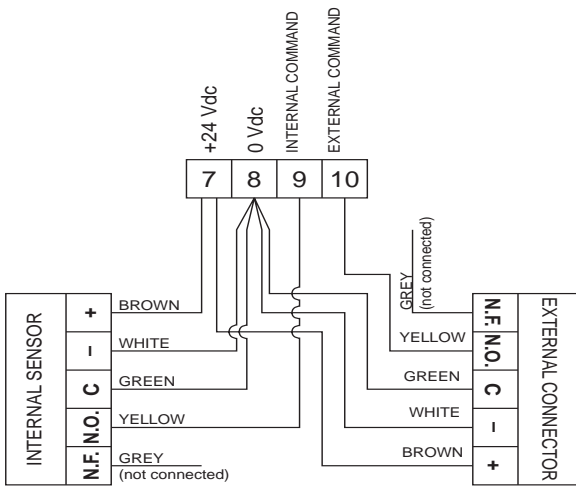

Fig. 18

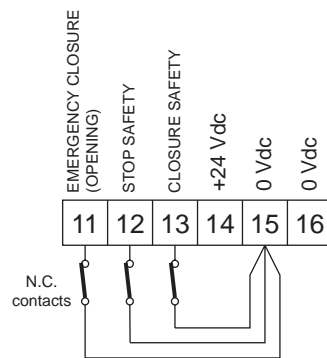

Fig. 19/a

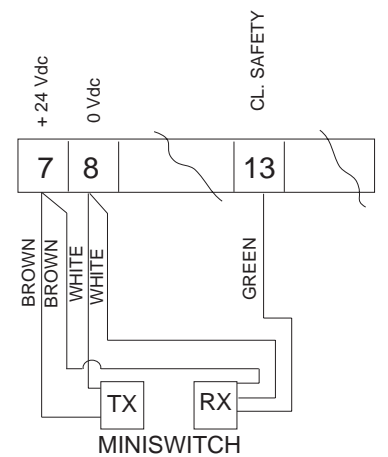

Fig. 19/b

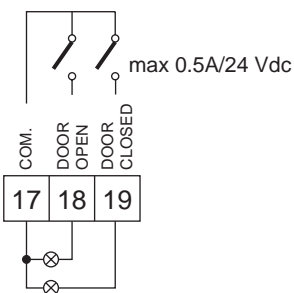

Fig. 20

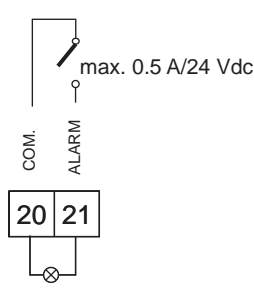

Fig. 21

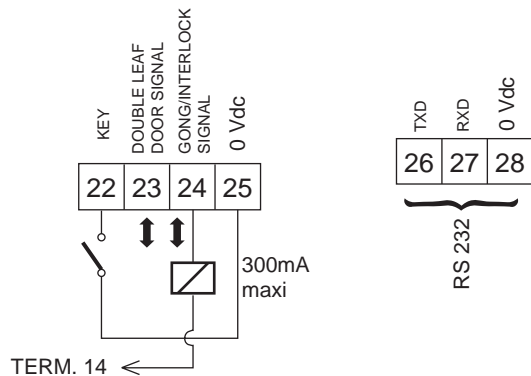

Fig. 22

Fig. 23

given to enable the mechanical release of the system.

- 7. **Accessories power supply (+24 Vdc)**
- 8. **Accessories power supply (0 Vdc)**
- 9. **Internal command:** any control device (pushbutton, photocell, sensor, etc.) which, by closing a contact, can command an opening cycle of the system from inside.
- 10. **External command:** any control device (pushbutton, photocell, sensor, etc.) which, by closing a contact, can command an opening cycle of the system from outside. Fig. 17 shows the control device connection. To install more than one internal/external control device, connect the N.O. contacts in parallel.
Connecting microwave radar / passive infrared sensors.
In the conventional configurations the control units are microwave radar and/or passive infrared sensors. To connect the FAAC sensors/radar units equipped with a 5-pole electrical cable, refer to fig. 18.
- 11. **Emergency control (fig. 19/a):** any control device (normally a pushbutton) which, by opening a contact, commands an emergency closure of the system. Alternatively this input can be used to command emergency opening by programming the system in a suitable manner using the CODIS programming unit (optional).
To install more than one emergency control device, connect the N.C. contacts in series.
N.B.: If emergency control devices are not connected, jumper inputs **11** and **15**.
Activating function no. 6 at CODIS programming level III enables the emergency control to be activated by closing a N.O. contact.
In this case, in order to install more than one emergency control device, connect the N.O. contacts in parallel.
- 12. **STOP safety control (fig. 19/a):** any device (safety sensor, photocell, etc.) which, by opening a contact, has a safety effect on the operating cycle. In particular, this safety device interrupts the opening/closing movement of the door.
When the safety device is disengaged, the door resumes its opening/closing movement and continues to the end of the cycle.
To install more than one STOP safety device, connect the N.C. contacts in series.
N.B.: If STOP safety devices are not installed, jumper inputs **12** and **15**.
- 13. **CLOSURE safety command (fig. 19/a):** any device (safety sensor, photocell, etc.) which, by opening a contact, has a safety function on the closing movement of the door. The safety device causes an immediate reversal of the closing movement of the door, but has no effect on the opening movement of the door.
To install more than one CLOSURE safety device, connect the N.C. contacts in series.
N.B.: If CLOSURE safety devices are not connected, jumper inputs **13** and **15**.
Connection of MINISWITCH photocells
The MINISWITCH photocells can be used as a safety device.

For connection, see **figure 19/b**.

- 14. **Accessories power supply (+24 Vdc)**
- 15. - 16. **Accessories power supply (0 Vdc)**
- 17. **Status signal output: Common (fig. 20)**
- 18. **Door open signal output** (max. contact capacity 0.5 A / 24 Vdc) (fig. 20)
- 19. **Door closed signal output** (max. contact capacity 0.5 A / 24 Vdc) (fig. 20).
Terminals 17/18 and 17/19 can be used to power two 24 Vdc (max. 0.5 A) warning lamps to provide door open and door closed signals respectively (fig. 20).
- 20. - 21. **Alarm signal output** (max. contact capacity 0.5 A / 24 Vdc).
Terminals 20 and 21 can be used to power a 24 Vdc (max. 0.5 A) warning lamp for remote signalling of an alarm condition (fig. 21).
The operator signals a malfunction by means of an acoustic alarm from a buzzer (see Table 6).
- 22. **"KEY" opening command (fig. 22):** any device which, by closing a contact for more than 3 seconds, commands door opening in any operating function selected.
To install more than one "KEY" command, connect the N.O. contacts in parallel.
- 23. **Output for "DOUBLE LEAF" application (fig. 22):** see section 9.2
- 24. **Output for GONG acoustic signal / Output for "INTERLOCK" application (fig. 22):**
When the CLOSURE safety device comes into operation, it activates the output between terminals 14 and 24 for one second at intervals of 0.5 seconds. The output is suitable for controlling an acoustic signal (GONG). The maximum load is 300 mA (fig. 22).
In the event of "INTERLOCK" operation, it is necessary to activate function no. 3 at CODIS level III and use outputs 24 and 25 for the connection between the two operators (see section 9.1).
- 25. **0 Vdc**
- 26. - 27. - 28. **PC connection:** These outputs allow for interfacing with a PC, which if necessary can control a number of doors from a single central unit (fig. 23).
For this application refer to the relevant technical manual.
- ④ **RESET button**
N.B.: To RESET, hold down the button for at least 4 seconds.
- ⑤ **Position monitoring microswitch connector (fig. 1 - ref. 4).**
- ⑥ **Programming unit connector (2 pole)**
- ⑦ **Programming unit connector (14 pole)**

7. FUNCTION SWITCH

The 961 B-E operator has a 3-position function switch (0-1-2) mounted on one of the end covers (fig. 1 - ref. 12). This cover can be fitted on the right or the left as required (fig. 8). The switch electrical connection is shown in fig. 13. The selectable operating functions are shown in fig. 24.

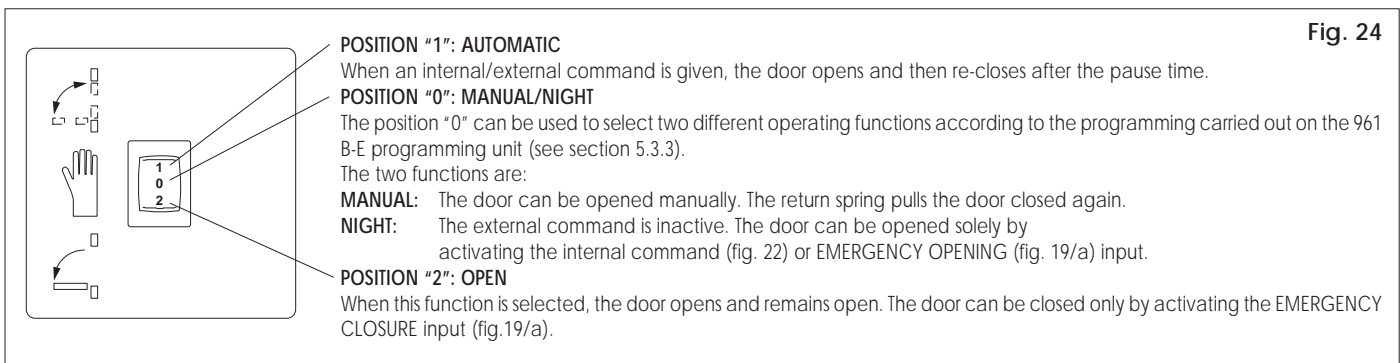

Fig. 24

8. "CODIS" EXTERNAL PROGRAMMING UNIT (OPTIONAL)

The 961 B-E automation unit can also be controlled by an external programming unit in place of the function selector and of the 961 B-E programming unit.

The CODIS (see figure 25) has four levels of operation, where the user can select the operating functions and set, programme and monitor the operation of the system.

If the CODIS is used permanently, it is necessary to activate function 7 at Level III (programming functions): see paragraph 8.3.

For the electrical connection of the CODIS, consult figure 14. The operation of the CODIS can be inhibited in the two following ways:

- by cutting the jumper between terminals 3 and 4 by means of a switch (fig. 14);
- by activating function 9 at Level III; in this case it is possible to operate the unit temporarily after having entered code "+ + - - + +" by means of the "+" and "-" pushbuttons.

After 2 minutes the CODIS will stop again automatically.

Note: the CODIS can also be used as a temporary programming unit. In this case, Level II (adjustable functions) is inactive.

When the programming of the system has been completed, the CODIS can be removed: all the programmed functions will remain unaltered.

After having removed the CODIS, perform a RESET or switch off the system.

8.1 LEVEL I - OPERATING FUNCTIONS

This is the level that is accessible to the user. By pressing either the "+" or the "-" pushbutton, the user can select the operating function.







Five operating functions are available. They are displayed on the left-hand side of the front panel of the CODIS.

When a function has been selected, the corresponding LED lights up on the front panel.

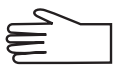
Press the "+" pushbutton to move the lighting of the LEDs one position up.

Press the "-" pushbutton to move the lighting of the LEDs one position down.

The five available functions displayed on the panel are:

-  o LED 6 **MANUAL**
The door is released and can be operated manually. The control devices are inactive.
-  o LED 5 **OPEN**
The door opens and remains open.
-  o LED 4 **AUTOMATIC**
The door opens when internal or external commands are active and re-closes after the pause time.
-  o LED 3 **AUTOMATIC (SPARE)**
-  o LED 2 **ONE-WAY**
Entry (or exit) inhibited; only one direction of exit (or entry); opening when internal (or external) command is active; closing after pause time. The external (or internal) control devices are inactive.
-  o LED 1 **NIGHT**
The door is locked shut by the electric lock. The external command is inactive. The door can be opened solely by activating the internal command or EMERGENCY OPENING input. The door closes after the night pause time.

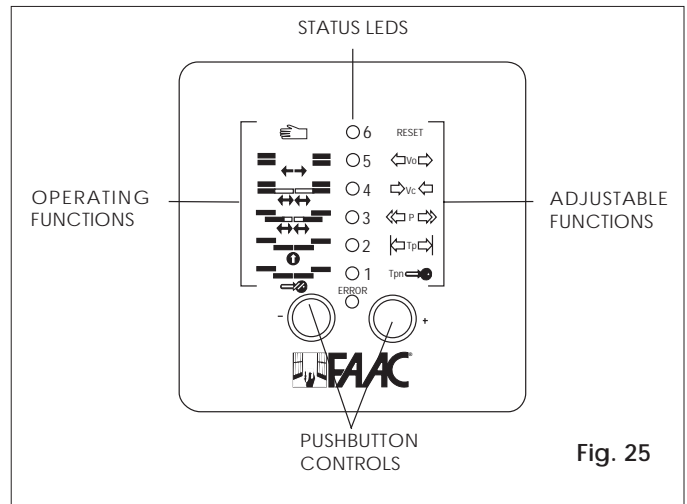







Fig. 25

8.2. LEVEL II - ADJUSTABLE FUNCTIONS

Important: Level II is active only if the CODIS is used permanently (function 7 of Level III activated). The CODIS programming unit has one adjusting level.

Six parameters can be set. They are displayed on the right-hand side of the CODIS front panel, with the relevant LEDs:

- RESET** LED 6 o **RESET:** repeat initialisation process (see paragraph 4.1).
-  LED 5 o **OPENING SPEED:** adjust to 30 ÷ 100% of initialisation value. The standard setting is 100%.
-  LED 4 o **CLOSING SPEED:** adjust to 30 ÷ 66% of initialisation value. The standard setting is 66%.
-  LED 3 o **OPENING EXCURSION:** adjust maximum opening by 60 to 100%. The standard setting is 100%.
-  LED 2 o **PAUSE TIME:** adjust to 0-30 seconds. The opening is controlled by means of the activation of the internal/external control devices. The standard setting is 2 seconds.
-  LED 1 o **NIGHT PAUSE TIME:** adjust to 0-30 seconds. The opening is controlled by means of the activation of the KEY/EMERGENCY OPENING commands. The standard setting is 7 seconds.

8.2.1. ADJUSTMENT OF PARAMETERS

To access Level II (adjustable functions), proceed as follows:

- 1) Select the parameter to be adjusted by causing the relevant LED to light up. Press the "+" pushbutton to move the lighting of the LEDs one position up. Press the "-" pushbutton to move the lighting of the LEDs one position down.
- 2) Press the "+" and "-" pushbuttons **simultaneously**. The LED relevant to the selected parameter will start flashing in order to give information about the stored value: if the flashing rate is high, a high door speed or a short pause time has been stored; if the flashing rate is low, a low door speed or a long pause time has been stored.
- 3) Press the "+" or "-" pushbutton repeatedly, in order to increase or decrease the flashing frequency of the LED, that is to say, to change the value of the selected parameter. When the "+" pushbutton is pressed, the door speed, opening excursion and pause time are increased.

When the "-" pushbutton is pressed, the door speed, opening excursion and pause time are decreased.

- Return to Level I (operating functions) by pressing the "+" and "-" pushbuttons **simultaneously**.

Notes: - The CODIS automatically returns to Level I after 2 minutes of inactivity.

- To prevent the settings from returning to standard values after a RESET or a voltage drop, "protect" the programmed values by activating function 18 at Level III (see paragraph 8.3).

8.3. LEVEL: III - PROGRAMMING FUNCTIONS

The CODIS has a programming level where certain functions can be selected.

These functions are required for several special applications.

Note: a voltage drop or a RESET command will not cancel the programming on Level III.

Standard programming can be restored by means of function 15 (see Table 7).

To access Level III, proceed as follows:

- Select the **NIGHT** operating function by causing LED 1 to light up. Press the "+" pushbutton to move the lighting of the LEDs one position up. Press the "-" pushbutton to move the lighting of the LEDs one position down.
- Press the "+" and "-" pushbuttons **simultaneously** for about **2 seconds**, until the red **ERROR** LED lights up.
- Enter the access code by pressing the "+" and "-" pushbuttons in the following sequence: "+ + + - - + + +".

Note: after the lighting up of the red ERROR LED, if the code is not entered **within 10 seconds** the CODIS will automatically return to Level I.

- Select the function to be programmed by pressing the "+" or "-" pushbutton so as to obtain the combination of lit LEDs indicated in Table 7.
- Press the "+" and "-" pushbuttons **simultaneously** to activate or deactivate the function, and check the status of LED 6, according to the indications of Table 7.

Note: the standard programming is the one with LED 6 unlit (OFF).

- To return to Level I (operating functions), **repeatedly** press the "-" pushbutton until all the six LEDs are off, then press the "+" and "-" pushbuttons **simultaneously**.

Note: the CODIS will automatically return to Level I after 2 minutes of inactivity.

8.3.1. AVAILABLE FUNCTIONS

function 1

One-way with lock activated: in the ONE-WAY operating function, the closed door is locked by the electric lock.

One-way with lock deactivated: in the ONE-WAY operating function, the closed door is not locked by the electric lock.

function 2

NIGHT function: the activation of the input between terminals 2 and 3 (960MP) selects the NIGHT operating function, **with priority** over the function selected on the CODIS.

ONE-WAY function: the activation of the input between terminals 2 and 3 (960MP) selects the ONE-WAY operating function, **with priority** over the function selected on the CODIS. The control panel will show which function has been selected, by means of the lighting up of LED 1 or 2.

When the input is deactivated, the operating function previously selected on the CODIS returns automatically.

function 3

Gong output: the operation of the closing safety device activates the 24 Vdc output between terminals 14 and 24 (960MP) for 1 second, at intervals of 0.5 seconds.

Table 7: programming functions

FUNCT.NO.	LEDS					FUNCTIONS	LED 6
	1	2	3	4	5		
0	OFF	OFF	OFF	OFF	OFF	Output Level III	OFF
1	ON	OFF	OFF	OFF	OFF	One-way with lock active One-way with lock inactive	OFF ON
2	OFF	ON	OFF	OFF	OFF	NIGHT function (terminal 3-960MP) ONE-WAY function (terminal 3-960MP)	OFF ON
3	ON	ON	OFF	OFF	OFF	Gong output (terminal 24-960MP) Interlock output (terminal 24-960MP)	OFF ON
4	OFF	OFF	ON	OFF	OFF	SLAVE (interlock) MASTER (interlock)	OFF ON
5	ON	OFF	ON	OFF	OFF	Emergency closing (terminal 11-960MP) Emergency opening (terminal 11-960MP)	OFF ON
6	OFF	ON	ON	OFF	OFF	Emergency command - N.C. contact (terminal 11-960MP) Emergency command - N.O. contact (terminal 11-960MP)	OFF ON
7	ON	ON	ON	OFF	OFF	CODIS - temporary connection CODIS - permanent installation	OFF ON
8	OFF	OFF	OFF	ON	OFF	15 kg static force 9 kg static force	OFF ON
9	ON	OFF	OFF	ON	OFF	CODIS inhibited inactive CODIS inhibited active	OFF ON
10	OFF	ON	OFF	ON	OFF	Standard opening pause time Immediate closing	OFF ON
11	ON	ON	OFF	ON	OFF	Door open/closed indication - N.O. contact (terminals 18/19-960MP) Door open/closed indication - N.C. contact (terminals 18/19-960MP)	OFF ON
12	OFF	OFF	ON	ON	OFF	Alarm warning - N.O. contact (terminal 21-960MP) Alarm warning - N.C. contact (terminal 21-960MP)	OFF ON
13	ON	OFF	ON	ON	OFF	"Double swing door" output inactive "Double swing door" output active (terminal 23-960MP)	OFF ON
14	OFF	ON	ON	ON	OFF	SLAVE (double swing door) MASTER (double swing door)	OFF ON
15	ON	ON	ON	ON	OFF	Restore STANDARD settings Retain programmed settings	OFF ON
16	OFF	OFF	OFF	OFF	ON	Opening commands stored (interlock) Opening commands not stored (interlock)	OFF ON
17	ON	OFF	OFF	OFF	ON	TEST programme inactive TEST programme active	OFF ON
18	OFF	ON	OFF	OFF	ON	Level II RESET active Level II RESET inactive	OFF ON
19	ON	ON	OFF	OFF	ON	STANDARD internal command (terminal 9-960MP) STEP-BY-STEP internal command (terminal 9-960MP)	OFF ON

Interlock output: between terminals 24 and 25 (960 MP) it is possible to pick up the signal for the interlocking of the two automation units (see paragraph 9.1).

function 4

SLAVE/MASTER: in the interlocking operation of the two automation units, it is necessary to define which door is to operate as MASTER (normally it is the inner one) and which door is to operate as SLAVE.

function 5

Emergency closing: the activation of the input between terminals 11 and 15 (960MP) controls the closing of the door no matter which operating function has been selected.

Emergency opening: the activation of the input between terminals 11 and 15 (960MP) controls the opening of the door no matter which operating function has been selected.

function 6

Emergency command - N.C. contact: to activate the input between terminals 11 and 15 (see function 5), an opening pulse of a N.C. contact is required.

Emergency command - N.O. contact: to activate the input between terminals 11 and 15 (see function 5), a closing pulse of a N.O. contact is required.

function 7

CODIS - temporary connection: the CODIS can be used only initially to activate certain functions. When the external programming unit is removed, the function that has been activated remains stored. In this case, Level II is inhibited, and the settings (speed, pause times, etc.) must be performed by means of the internal 961 B-E programming unit.

CODIS - permanent installation: the CODIS is installed permanently; the four operating levels are all active.

function 8

15 kg static force / 9 kg static force: this function makes it possible to change the sensitivity of the anti-crushing device.

function 9

CODIS inhibited inactive / CODIS inhibited active: this function makes it possible to activate the CODIS electronic inhibition. In this condition, no programming can be performed at any level.

To release the CODIS temporarily, press the "+" and "-" pushbuttons in the following sequence: "+ + - - + +".

This operation may be carried out for two purposes:

- 1) to change the operating function or modify some settings at Level II; in this case, after 2 minutes the CODIS inhibition will come again;
- 2) to remove the CODIS inhibition; in this case, it is necessary to access Level III and to disable that function.

function 10

Standard opening pause time: the pause time begins with the door open and the control devices (e.g., sensors) inactive.

Immediate closing: the door closes when the control devices (e.g., sensors) are inactive. In this case, directional sensors must be used.

function 11

Door open/closed indication - N.O. contact: the open and closed positions of the door are indicated by the closing of an N.O. contact (terminals 18/19-960MP).

Door open/closed indication - N.C. contact: the open and closed positions of the door are indicated by the opening of a N.C. contact (terminals 18/19-960MP).

function 12

Alarm warning - N.O. contact: the alarm condition is indicated by the closing of a N.O. contact.

Alarm warning - N.C. contact: the alarm condition is indicated by the opening of a N.C. contact.

function 13

"Double swing door" output inactive/active: between terminals 23 and 25 (960MP) it is possible to pick up the signal for the operation of a double swing door (see paragraph 9.2).

function 14

SLAVE / MASTER: in the application for a double swing door, the automation of the leaf whose opening is to be anticipated must be programmed as MASTER, while the automation of the leaf whose opening is to be delayed must be programmed as SLAVE.

function 15

Restore STANDARD settings / Retain programmed functions: this function makes it possible to check whether any function has been programmed differently from the standard settings. If at least one function has been programmed differently from the standard settings, LED 6 is lit (ON).

In this case all the standard settings can be restored by pressing the "+" and "-" pushbuttons simultaneously.

After this operation, it is advisable to perform a RESET.

function 16

Opening commands stored (interlock): in interlock operation, it is not necessary to wait until one door has closed before commanding the opening of the other.

Opening commands not stored (interlock): in interlock operation, it is necessary to wait until one door has closed before commanding the opening of the other.

Opening commands given during the operating cycle of the first door will have no effect.

function 17

TEST programme inactive/active: this function makes it possible to activate consecutive operating cycles. The control devices, in any case, take priority over the operation of the system. The programme can be cancelled by performing a RESET.

function 18

Level II RESET active / inactive: this function makes it possible to preserve the settings of the opening, closing and opening excursion speeds even in case of a voltage drop or RESET.

function 19

STANDARD internal command: the activation of the internal control device controls a complete door cycle (standard operation).

STEP-BY-STEP internal command: the activation of the internal control device controls a sequence of door opening / stopping / closing / stopping / opening, and so on.

8.4. LEVEL IV - SELF-DIAGNOSIS

The CODIS programming unit has a self-diagnostic level, which, in case of a fault, interrupts the display of the operating function every 2 seconds in order to display the malfunction condition for 0.5 seconds. The type of fault can be identified by observing the combination of LEDs 1-5 that are lit together with the red ERROR LED (see Table 8).

Table 8

NO.	LEDS					FAILURE	NOTE
	1	2	3	4	5		
							(*)
1	ON	OFF	OFF	OFF	OFF	Motor fault	B
2	OFF	ON	OFF	OFF	OFF	Governor and brake fault	B
3	ON	ON	OFF	OFF	OFF	Initialisation process not possible Opening angle insufficient	B
4	OFF	OFF	ON	OFF	OFF	Initialisation process not possible Opening angle excessive	B
5	ON	OFF	ON	OFF	OFF	Friction or spring load excessive	B
6	OFF	ON	ON	OFF	OFF	Spring load insufficient	B
7	ON	ON	ON	OFF	OFF	Motor overload	B
8	OFF	OFF	OFF	ON	OFF	Encoder fault (disconnected or in short circuit)	B
9	ON	OFF	OFF	ON	OFF	Cut-off relay fault	B
10	OFF	ON	OFF	ON	OFF	EPROM / RAM / relay fault (automatic control)	B
11	ON	ON	OFF	ON	OFF	Short circuit on 24 V (960MP electronic control unit or external)	B
12	OFF	OFF	ON	ON	OFF	Monitoring microswitch fault	A
13	ON	OFF	ON	ON	OFF	Electric lock fault	B
14	ON	ON	ON	ON	OFF	Power supply insufficient (< 140 V)	B
15	OFF	OFF	OFF	OFF	ON	Microprocessor fault	B
16	ON	OFF	OFF	OFF	ON	Incorrect "door closed" position	A
17	OFF	ON	OFF	OFF	ON	Microprocessor alarm	B
18	ON	ON	OFF	OFF	ON	"Double swing door" communication error	A

(*) A: this error condition does not inhibit the operation of the system.
 B: this error condition inhibits the operation of the automation unit until the fault has been eliminated.

9. SPECIAL APPLICATIONS

9.1. INTERLOCK

The programmable interlock function makes it possible to interlock the operation of two doors so that the opening of one is dependent on the closing of the other and vice versa.

Electrical connections

- Connect the two automations to the same power supply line.
- Connect the X2 terminal strips of the two 960MP electronic control units to each other, as shown in Figure 26.
- Connect the control devices and the emergency command, if present, as shown in figure 27.

The emergency command makes it possible for the two doors to open or close simultaneously, depending on the programming performed on the CODIS (see Table 7, function 5).

Note: the control devices must be connected **only** to the KEY input (see figure 27).

Programming and selection of operating function

To enable the interlock operation, the appropriate programming of the following Level III functions must be performed (see paragraph 8.3):

- **Function 3:** select the **Interlock output** option on both the CODIS programming units (LED 6 lights up).
- **Function 4:** select the **MASTER** option on the CODIS unit of the inner door (LED 6 lights up); select the **SLAVE** option on the CODIS unit of the outer door (LED 6 goes out).
- **Function 16:** select the desired option on both the CODIS programming units.

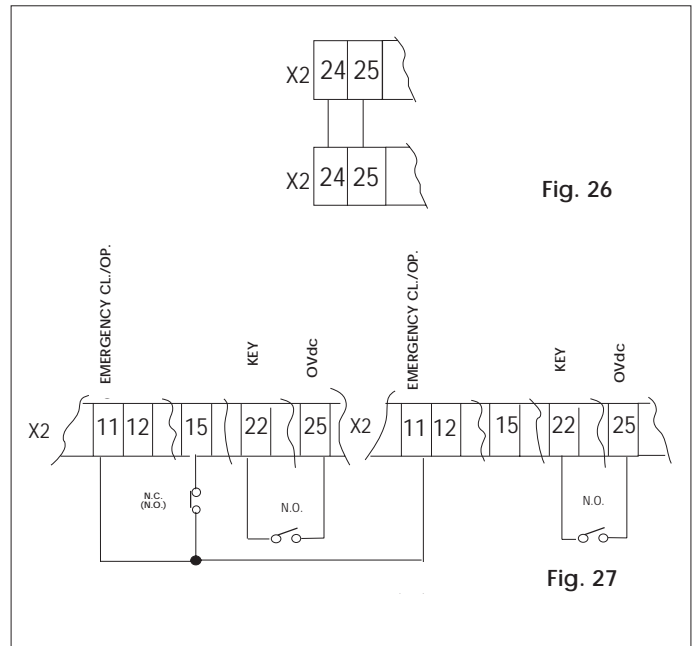

If the **Opening commands stored** option has been selected (LED 6 unlit), it is not necessary to wait for one of the doors to close before controlling the opening of the other. When the closing of the first door has been completed, the second door opens automatically.
 If the **Opening commands not stored** option has been selected (LED 6 lit) it is necessary to wait for one of the doors to close before controlling the opening of the other. Opening commands given during the operating cycle of the first door will have no effect.

Table 9 indicates the functions to be programmed.

Table 9

FUNCT.NO.	LEDS					FUNCTIONS	LED 6
	1	2	3	4	5		
3	ON	ON	OFF	OFF	OFF	Gong output (terminal 24-960MP) Interlock output (terminal 24-960MP)	OFF ON
4	OFF	OFF	ON	OFF	OFF	SLAVE (interlock) MASTER (interlock)	OFF ON
16	OFF	OFF	OFF	OFF	ON	Opening commands stored (interlock) Opening commands not stored (interlock)	OFF ON

IMPORTANT: the interlock operation is activated only if the **NIGHT** or **ONE-WAY** operating function has been selected on both the CODIS programming units (see paragraph 8.1).

9.2. DOUBLE SWING DOOR

The programmable "double swing door" function makes it possible to synchronise the movement of the two leaves that face each other (see figure 29). For a correct operation of the system, the opening of one leaf must be anticipated and its closing must be delayed.

Note: the difference between the opening angles of the two leaves must not exceed 20°.

Electrical connections and programming

- Connect the X2 terminal strips of the two 960MP electronic control units to each other, as shown in figure 28.
- Connect the internal and external control devices, the emergency command, if present, and the electric lock to the electronic control unit of the MASTER automation (see fig. 29).

Note: the MASTER automation actuates the leaf whose opening

movement must be anticipated (and whose closing movement must be delayed).

- Connect the safety devices on the 960MP electronic control units of the MASTER and SLAVE automations.
- Connect the two automations to the same power supply line.
- On both the automations, activate **function 13**, “double swing door” output (ON), then define which is the MASTER leaf and which is the SLAVE one by programming **function 14** (fig.29).

Table 10 indicates the functions to be programmed.

Table 10

FUNCT.NO.	LEDS					FUNCTIONS	LED 6
	1	2	3	4	5		
13	ON	OFF	ON	ON	OFF	“Double swing door” output inactive	OFF
						“Double swing door” output active	ON
14	OFF	ON	ON	ON	OFF	SLAVE (double swing door)	OFF
						MASTER (double swing door)	ON

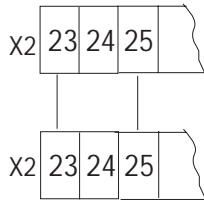

Fig. 28

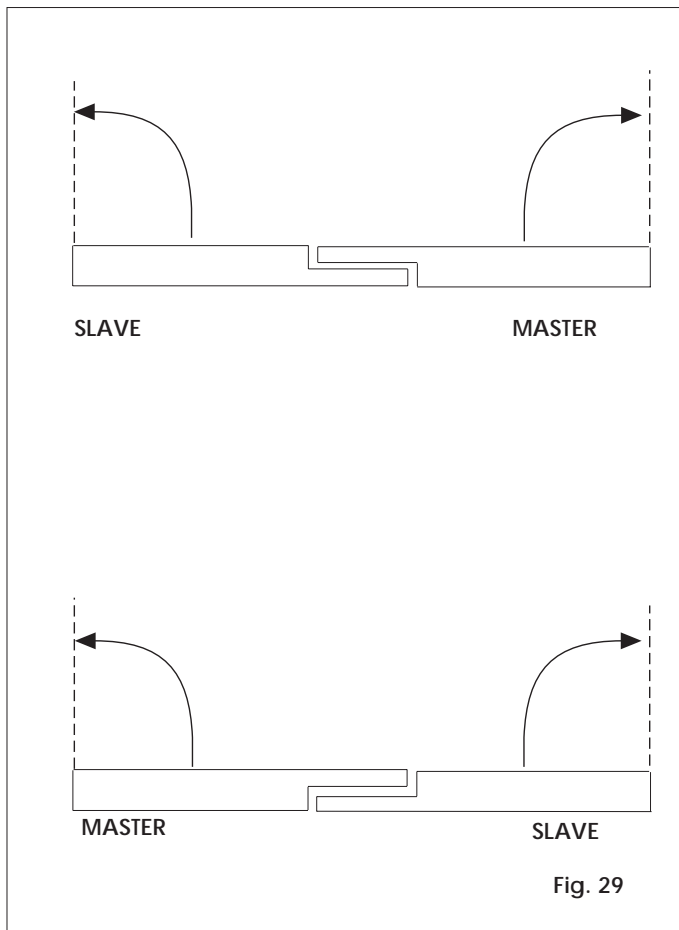

Fig. 29

10. MAINTENANCE

It is advisable to check the automation unit once a year, in order to make sure that the dragging system and closing spring are in perfect working order.

Drive system (fig. 1 - ref. 7)

Check the toothed wheels and, if necessary, lubricate them with grease for gears or bearings TRIBOTECH VTP 473.

Important: never use spray lubricants.

Closing spring (fig. 1 - ref. 10)

With the door closed, draw a vertical line on the spring, as shown in figure 30.

Open the door and check the state of the line: figure 30 shows two possible configurations.

In case B (fig. 30), lubricate the spring coils with **KLÜBER MICROLUBE GBU Y 131** grease, with the door both open and closed.

Adjustment of spring load

If the spring load is insufficient or excessive, proceed as follows:

- 1) Select the MANUAL function (function selector in position “0”).
- 2) Release the arm fastened to the shaft from the second transmission arm.
- 3) Keep the arm in position and remove the screw that adjusts the spring load (fig. 1 - ref. 5).
- 4) Load or unload the spring by rotating the arm in the appropriate direction, and insert the screw in positioning bore K (fig. 31).
- 5) Restore the system and check its operation is correct.
- 6) Perform any adjustments that may be needed, and lock the adjusting screw (fig. 1 - ref. 5) with Loctite.

Important: after the adjustment of the spring load, the system travel must be initialised. Proceed as follows:

- Remove the arm from the drive shaft.
- Set all the microswitches of the 961 B-E programming unit (fig. 9 - ref. 4) to position OFF.
- Rotate all the adjusting trimmers (fig. 9 - ref. 3) counterclockwise all the way.
- Press the RESET pushbutton for at least 4 seconds.
- After the initialisation cycle has been completed, switch off the power supply, restore the automation system, and perform the start-up as described in paragraph 4.

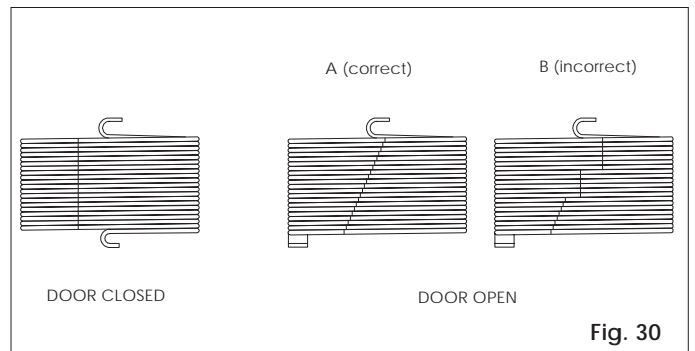

Fig. 30

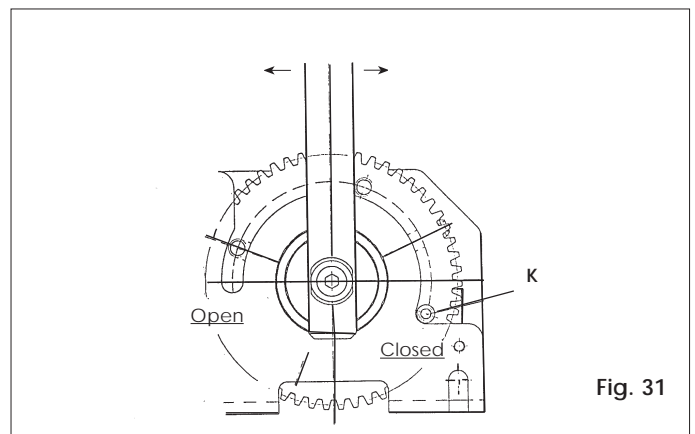

Fig. 31

END-USER GUIDE

961 B-E Automation Systems

Read the end user guide carefully before using the product and keep it in a safe place for future reference.

GENERAL SAFETY REGULATIONS

When correctly installed and used, the 961 B-E automatic unit assures a high level of safety. A few simple rules should be followed to prevent problems from arising accidentally:

- Do not stand or allow children or adults to stand within range of the door, especially during operation, and do not leave objects near it.
- Do not allow children to play with the door.
- Do not deliberately obstruct movement of the door.
- Keep the "automatic door" signs efficient and clearly visible.
- In the event of a malfunction, select MANUAL OPERATION and wait for a qualified technician to perform the necessary repair work.
- Do not modify the components of the automatic unit.
- Do not attempt to repair the automatic unit or to perform any operation on it. Call qualified FAAC technicians only.
- At least once every 6 months have qualified personnel check that the automatic unit, safety devices and earth connection are in working order.

DESCRIPTION







The 961 B-E automatic unit for swing doors is a one-piece unit consisting of an electromechanical device that allows door opening to be controlled by means of a driving arm. The door is re-closed by a spring system.

The operator can be installed either on the lintel or on the door structure itself.

The stainless steel protective casing houses the electronic control unit used to program and control the operation of the system.

The automatic unit 961 B-E has a selector which can be used to choose the operating logic shown in fig. 1. A CODIS programming unit (fig. 2) can be installed as an alternative to the function selector, in which case the following operating functions are available:

OPERATING FUNCTIONS

- | | | |
|--|---------|--|
|  | o LED 6 | MANUAL
The door is released and can be operated manually.
The control devices are inactive. |
|  | o LED 5 | OPEN
The door opens and remains open. |
|  | o LED 4 | AUTOMATIC
The door opens when internal or external commands are active and re-closes after the pause time. |
|  | o LED 3 | AUTOMATIC (SPARE) |
|  | o LED 2 | ONE-WAY
Entry (or exit) inhibited; only one direction of exit (or entry); opening when internal (or external) command is active; closing after pause time. The external (or internal) control devices are inactive. |
|  | o LED 1 | NIGHT
The door is locked shut by the electric lock. The external command is inactive. The door can be opened solely by activating the internal command or EMERGENCY OPENING input. The door closes after the night pause time. |

The different logic modes are active when the corresponding LED is illuminated steadily. To change the operating function press the + or - control button.

MANUAL OPERATION

If the door has to be activated manually due to failure of the electrical power supply or a malfunction of the automatic unit, proceed as follows:

Function selector

- Turn the selector to the "0" MANUAL/NIGHT position
- Open or close the door manually

CODIS unit

- Press the + button to set the operating function to the manual position with LED 6 lit steadily.

RETURN TO NORMAL OPERATION

Function selector

- Turn the function selector to the "1" AUTOMATIC position.

CODIS unit

- Press the - button to set the operating function in the desired position (LED lit steadily). See fig. 2.

