

EC MACHINE DIRECTIVE COMPLIANCE DECLARATION

(DIRECTIVE 89/392 EEC, APPENDIX II, PART B)

Manufacturer: FAAC S.p.A.

Address: Via Benini, 1
40069 - Zola Predosa
BOLOGNA - ITALY

Hereby declares that: the 884 MCT automation system

- is intended to be incorporated into machinery, or to be assembled with other machinery to constitute machinery in compliance with the requirements of Directive 89/392 EEC, and subsequent amendments 91/368 EEC, 93/44 EEC and 93/68 EEC;
- complies with the essential safety requirements in the following EEC Directives:

73/23 EEC and subsequent amendment 93/68 EEC.
89/336 EEC and subsequent amendments 92/31 EEC and 93/68 EEC.

and furthermore declares that unit must not be put into service until the machinery into which it is incorporated or of which it is a component has been identified and declared to be in conformity with the provisions of Directive 89/392 EEC and subsequent amendments enacted by the national implementing legislation.

Bologna, 1 January 2001

Managing
Director
A. Bassi

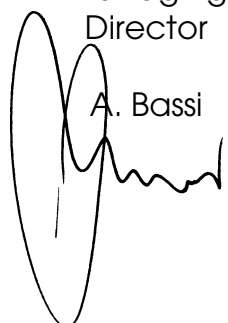

IMPORTANT NOTICE FOR THE INSTALLER

GENERAL SAFETY REGULATIONS

- 1) **WARNING! FAAC strongly recommends to follow these instructions literally for the safety of persons. Improper installation or misuse of the product will cause very serious damages to persons.**
- 2) Read the instructions carefully before installing the product.
- 3) Packaging material (plastic, polystyrene etc.) is a potential hazard and must be kept out of reach of children.
- 4) Keep these instructions for future reference.
- 5) This product has been designed and manufactured only for the use stated in this manual. Any other use not expressly set forth will affect the reliability of the product and/or could be source of hazard.
- 6) FAAC S.p.A. cannot be held responsible for any damage caused by improper use or different from the use for which the automation system is destined to.
- 7) Do not use this device in areas subject to explosion: the presence of flammable gas or fumes is a serious hazard.
- 8) Mechanical constructive elements must comply with UNI8612, EN 12604 and EN 12605 standards. Countries outside the EC shall follow the regulations above besides their national normative references in order to offer the utmost safety.
- 9) FAAC cannot be held responsible for failure to observe technical standards in the construction of gates and doors, or for any deformation of the gates which may occur during use.
- 10) Installation must comply with UNI8612, EN 12453 and EN 12445.
- 11) Before carrying out any operations, turn off the system's main switch.
- 12) An omnipower switch shall be provided for the installation with an opening distance of the contacts of 3 mm or more. Alternatively, use a 6A thermomagnetic breaker with multi-pole switching.
- 13) Ensure that there is a differential switch up-line of the electrical system, with a trip threshold of 0.03A.
- 14) Check that the earthing plant is in perfect condition and connect it to the metallic parts. Also earth the yellow/green wire of the operator.
- 15) The safety devices (e.g. photocells, safety edges, etc.) protect areas wherethere is a **mechanical movement hazard**, e.g. crushing, entrapment and shearing.
- 16) Each installation must be fitted with at least one flashing light (EN 12978 standard) as well as a warning plate suitably fixed to the gate, besides the safety devices as per point 15. above.
- 17) FAAC cannot be held responsible regarding safety and correct functioning of the automation in the event that parts other than FAAC original parts are used.
- 18) Use only FAAC original spare parts for maintenance operations.
- 19) Do not carry out any modifications to automation components.
- 20) The installer must supply all information regarding manual operation of the system in the event of an emergency and provide the end-user with the "End-user Guide" attached to the product.
- 21) Keep out of persons when the product is in operation.
- 22) Keep out of reach of children the remote radio controls and any control devices. The automation could be operated unintentionally.
- 23) The end-user must avoid any attempt to repair or adjust the automation personally. These operations must be carried out exclusively by qualified personnel.
- 24) **What is not explicitly stated in these instructions is not permitted.**

AUTOMATION 884 & 884 T

These instructions apply to the following models:

884 MCT

The FAAC model 884 automations for sliding gates are electromechanical operators which transmit movement to the leaf by means of a pinion with rack coupled in an appropriate manner to the sliding gate.

By using a self-braking motor the system is guaranteed to be mechanically locked when the motor is not in operation so a lock does not need to be installed. The gear motors have adjustable mechanical clutches to ensure correct use of the automation. A convenient manual release device allows the gate to be opened in the event of a power failure or malfunction. The electronic control unit is incorporated in the gear motors.

The 884 automations have been designed and built for vehicle access control in industrial areas. Do not use for any other purpose.

1. DIMENSIONS

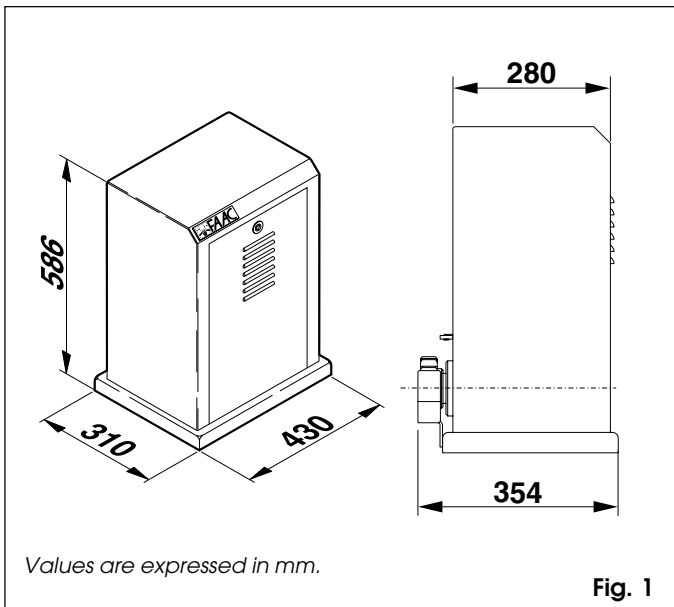

Fig. 1

2. DESCRIPTION AND TECHNICAL SPECIFICATIONS

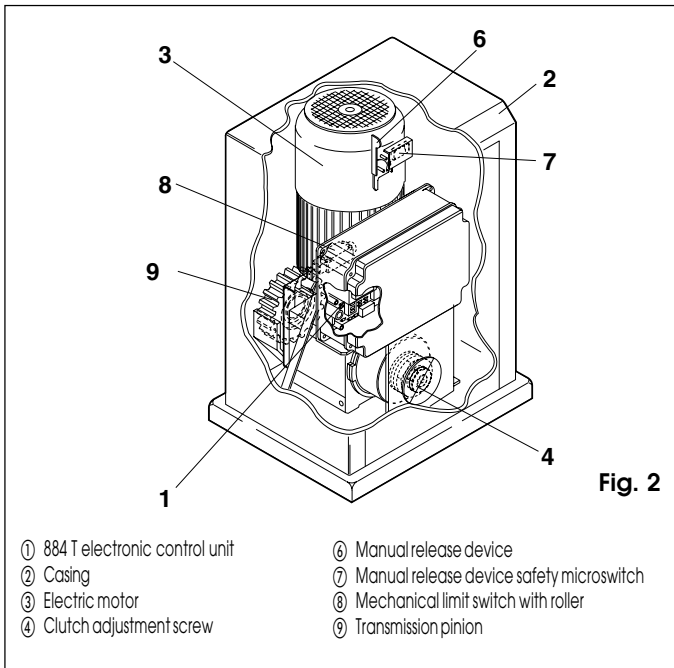

Fig. 2

Table 1 Technical specifications

Power supply	230V 3ph / 400V 3ph + N (+ 6 % - 10 %) 50Hz
Power consumption (W)	850
Reduction ratio	1 : 43,2
No. of pinion teeth CR	Z 16 - Rack 30x30 Module 6
Nominal torque Nm	155
Max. thrust N	3200
Duty rating	50% / 100% (2000 Kg)
Oil quantity (kg)	2
Temperature range	-20 ÷ + 55 °C
Gear motor weight (kg)	50
Housing protection	IP 55
Max. gate weight (kg)	3500
Gate speed	10 m/min
Max. gate length	42 m
Clutch	Twin discs in oil bath
Housing treatment	cataphoresis
Casing painting	polyester RAL 2004
Control unit	884 T (incorporated)
Limit switches	mechanical
Gear motor dimensions LxHxD (mm)	see Fig. 1

Electric motor technical specifications	
Power supply	230V (+ 6 % - 10 %) / 400V (+ 6 % - 10 %)
Frequency Hz	50
Current A	2.7 / 1,6
Power consumption kW	0.8
Motor speed rpm	1400

3. ELECTRICAL SET-UP

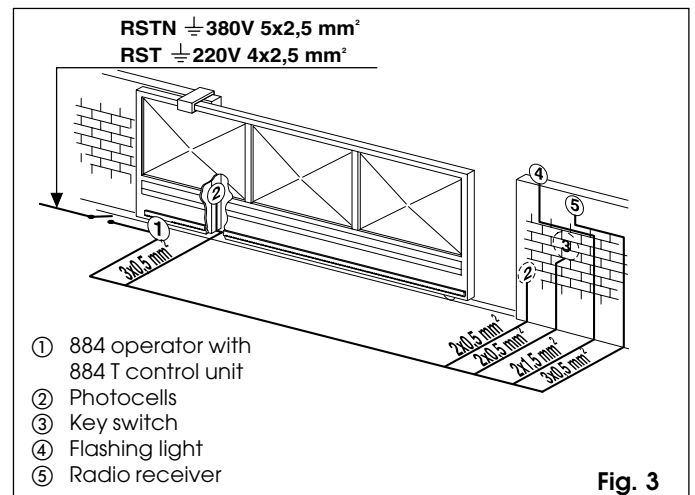

Fig. 3

4. INSTALLING THE AUTOMATION

4.1. PRELIMINARY CHECKS

For safe, correct operation of the automation, make sure that the following requirements are met:

- The gate's structure must be suitable for automation. Take special care to ensure that the wheels are large enough to support the full weight of the gate, that a top runner is installed and that mechanical limit stops are fitted to prevent the gate from coming off the runner.
- The characteristics of the ground must ensure sufficient support for the foundation plinth.
- There must be no pipes or electrical cables in the area to be dug for installing the foundation plinth.

- If the gear motor is located in a vehicle transit area, it is a good idea to provide protection against accidental collisions.
- Check that the gear motor has an efficient earth connection.

4.2. INSTALLING THE BASE PLATE

- 1) The base plate must be positioned as shown in Fig. 4. For the positioning distances refer to fig. 5.

Important: The plate must be level with the middle of the pinion. Remember to maintain a minimum distance of 10 mm between the rack and the gate.

- 2) Assemble the foundation plate as shown in A, Fig. 4.
- 3) Prepare a foundation plinth as shown in Fig. 4 and install the base plate providing one or more conduits for electrical cables. Use a level to check that the plate is perfectly horizontal and wait for the cement to set.

N.B.: It is advisable to install the plate slightly raised from the ground. See A, fig. 9.

- 4) Set up the electrical cables for connection to the accessories and the electricity supply as described in section 5. For ease of connection, ensure that the cables protrude by about 1 m from the hole in the base plate.

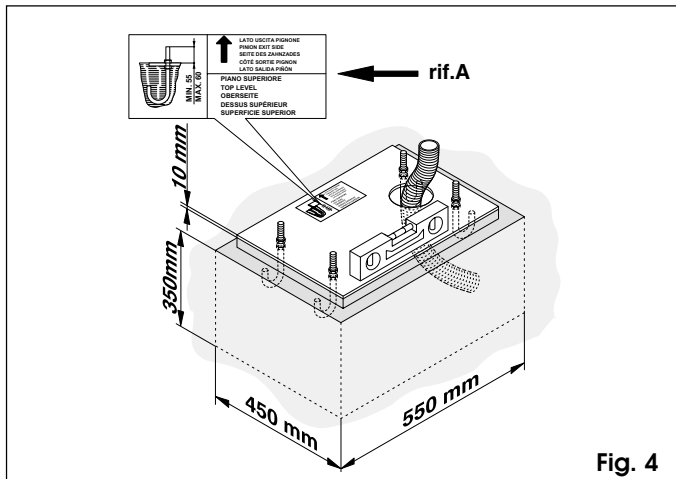

Fig. 4

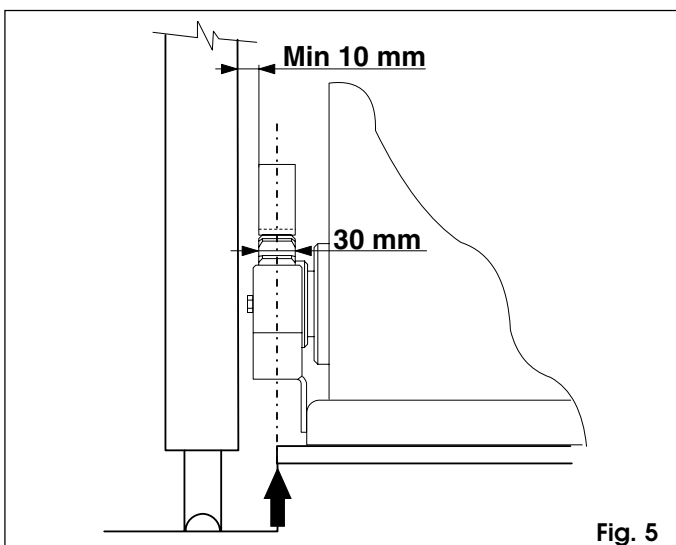

Fig. 5

4.3. MOUNTING THE PINION

Before mounting the operator on the foundation plate, mount the pinion on the transmission shaft and fit the casing provided as shown in fig. 6.

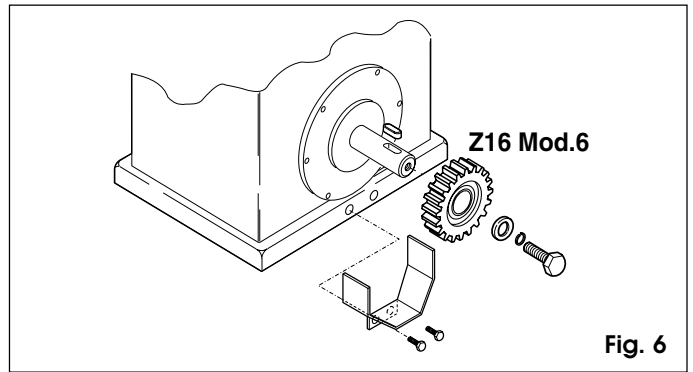

Fig. 6

4.4. MECHANICAL INSTALLATION

- 1) Remove the casing (2, fig. 2) and position the gear motor on the foundation plate. Fit, but do not tighten, the washer, the split washer and the nut as shown in fig. 7.

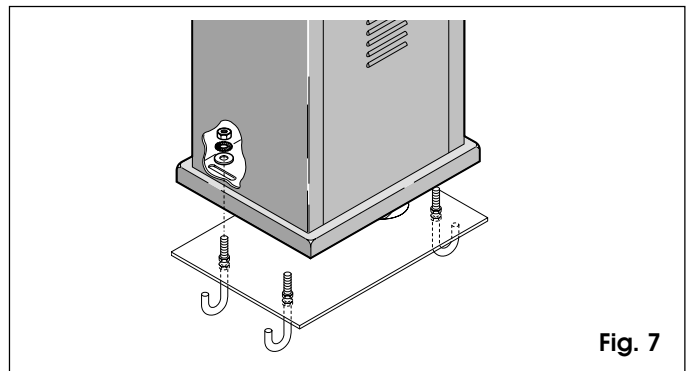

Fig. 7

- 2) Fit the adjustment screws on the gear motor base as shown in A, fig. 8.
- 3) Adjust the height of the feet while keeping the gear motor raised from the plate by 1 cm and maintaining the distance from the gate shown in figs. 5 and 9.
- 4) Use a level to check that the operator is perfectly horizontal.
- 5) Tighten up the four securing nuts provisionally.
- 6) Set up the operator for manual operation as described in section 7.

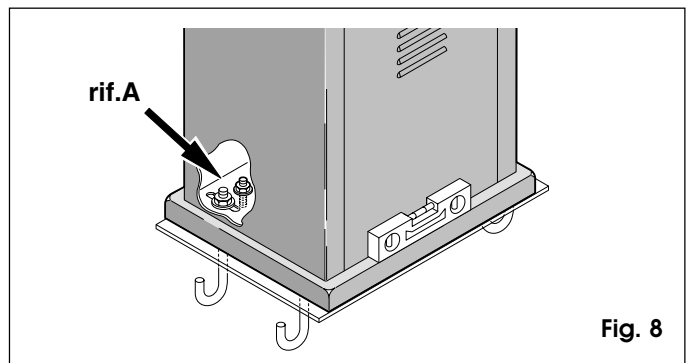

Fig. 8

4.5 MOUNTING THE RACK

Important: To mount the rack on the leaf it is necessary to construct special supports specifically for the type of gate. Fig. 10 shows an example of "L" support. For positioning the supports refer to figs. 5 and 9.

- 1) Slide the leaf manually to the closed position.
- 2) Rest the first rack element level on the pinion and weld the support onto the gate as shown in fig. 11.
- 3) Move the gate manually making sure that the rack rests on the pinion and weld the remaining supports.

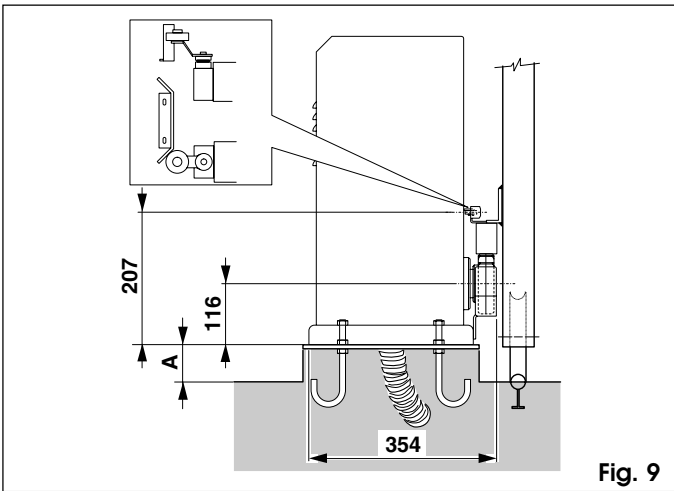

Fig. 9

- 4) Place another rack element next to the first and use a section of rack to set the teeth of the two elements in phase as shown in 11A.
- 5) Open the gate manually and weld the remaining supports. Proceed in this manner for all the rack elements and supports until the entire gate has been covered.

N.B.: Check that none of the rack elements come off the pinion during the movement of the gate.

Important: Do not weld the rack elements together.

After installing the rack, lower the position of the gear motor (fig. 12) by adjusting the level screws (A, Fig. 8) by about 4 mm to ensure correct meshing with the pinion. Screw up tightly the 4 gear motor securing nuts.

Check manually that the gate reaches the mechanical travel limits correctly and that it does not encounter friction during its travel.

Do not use grease or other lubricants between the pinion and the rack.

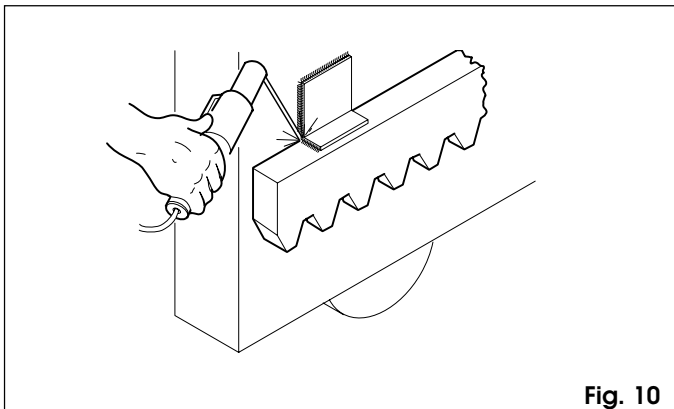

Fig. 10

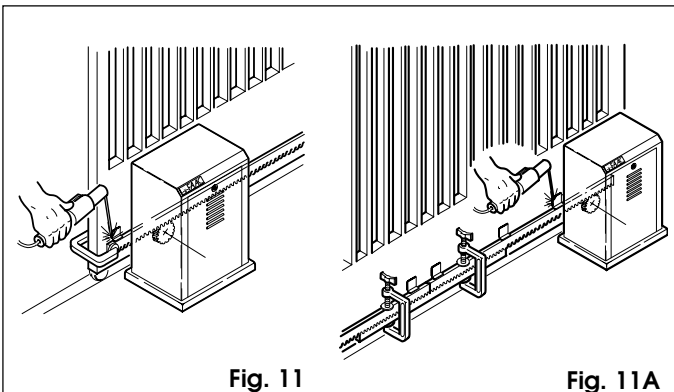

Fig. 11

Fig. 11A

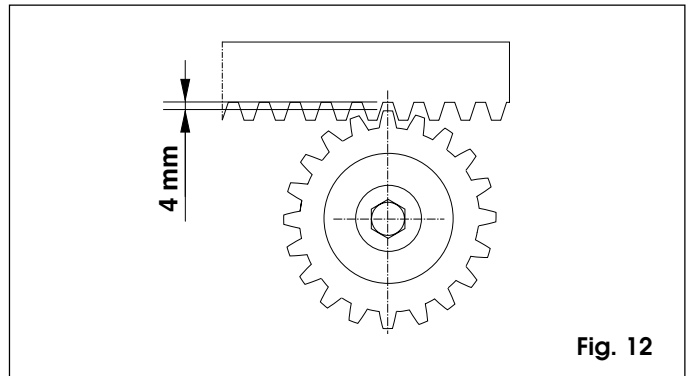

Fig. 12

5. START-UP

5.1. CONNECTION OF CONTROL BOARD

Important: Before attempting any work on the control board (connections, programming, maintenance), always turn off power.

Observe points 10, 11, 12, 13 and 14 of the GENERAL SAFETY OBLIGATIONS.

Install, upstream of the system, a differential thermal cutout with adequate tripping threshold.

Connect the earth cable to the appropriate seat on the operator base (see fig.20).

The operator is equipped with a safety device (fig.1 - ref.7), activated by the release device. If enabled, it prevents any manoeuvre by the operator.

Observing the instructions in Fig.3, lay the raceways and make the electric connections of the 884 T control board to the selected accessories.

Always separate power cables from control and safety cables (push-button, receiver, photocells, etc.). To prevent any electronic noise whatever, use separate sheaths.

TAB. 2 Technical specifications of 884 T

Power supply	400V 3ph+N / 230 3ph (+6 -10 %) 50Hz
Motor max load	1300W
Power supply for accessories	24 Vdc
Accessories max load	0.5A
Power supply to indicator-light	24 Vac (5W max)
Operating ambient temperature	-20 °C +55 °C
Protection fuses	transformer primary winding accessories
Function logics	Automatic 1/Automatic 2 Semi-automatic 1/Semi-automatic 2 Safety device 1/Safety device 2 Semi-automatic B/"Dead-man" C
Pause time	Adjustable by dip-switch
Terminal board inputs	Open/Partially open (Close) / Stop Closing safety devices/Limit-switch Power supply
Terminal board outputs	Flashing Lamp/Motor 24 Vdc power supply for accessories 24 Vac power supply to indicator-light
Rapid connector	SL-DS decoding cards and RP card receivers
Selectable functions	Function logics Pause times/Pre-flashing Indicator-light behaviour
Safety timer	255 sec.

5.1.1. LAYOUT

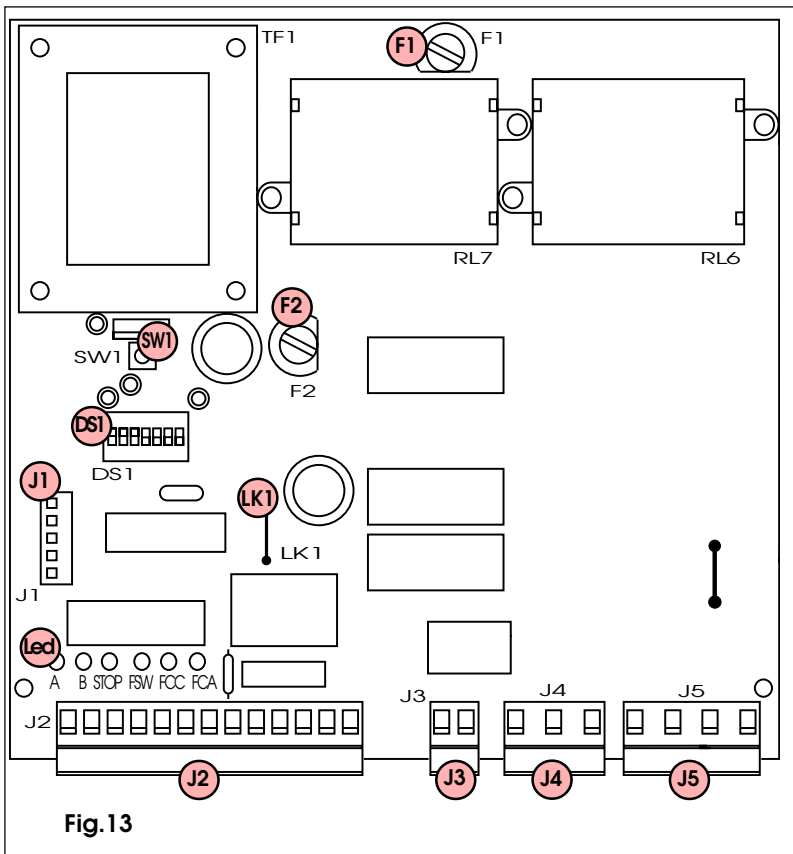
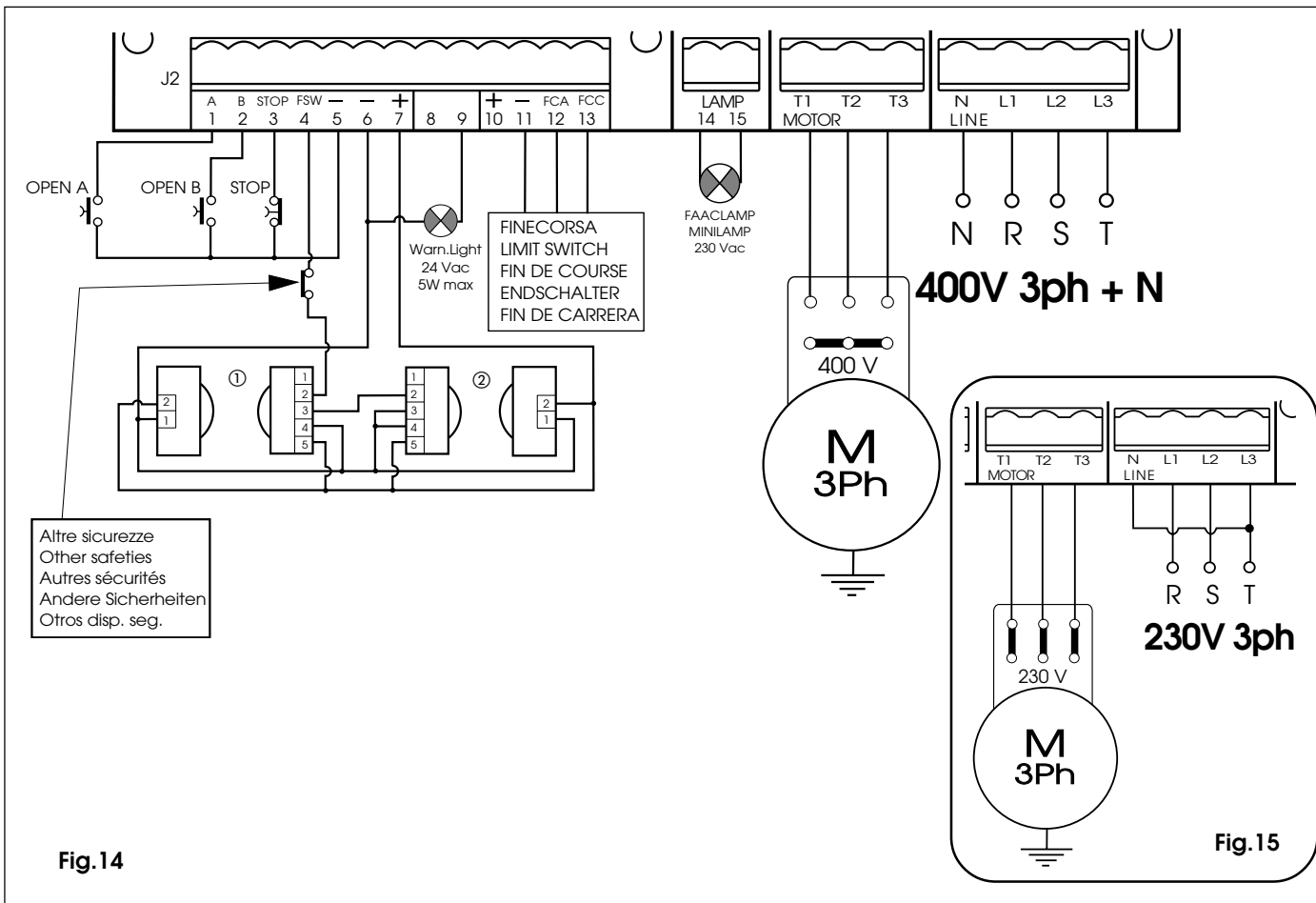

TABLE 3 Components of 884 T control board

LED A	LED OPEN
LED B	LED OPEN PARTIALLY / CLOSE
LED STOP	LED STOP
LED FSW	LED: SAFETY DEVICES
LED FCC	LED: CLOSING LIMIT-SWITCH
LED FCA	LED: OPENING LIMIT-SWITCH
SW1	RESET PUSH-BUTTON
J1	DECODER CONNECTOR
J2	LOW VOLTAGE TERMINAL BOARD
J3	FAAC LAMP CONNECTION TERMINAL BOARD
J4	MOTOR CONNECTION TERMINAL BOARD
J5	3-PHASE POWER SUPPLY TERMINAL BOARD
F1	TRANSFORMER PRIMARY WINDING FUSE (F 5A)
F2	ACCESSORIES FUSE (T 1.6A)
LK1	INDICATOR-LIGHT FREE CONTACT
DS1	PROGRAMMING MICROSWITCHES

5.1.2. ELECTRICAL CONNECTIONS



5.2. DESCRIPTION

5.2.1. J1 CONNECTOR

The J1 connector is used for rapid connection of cards MINIDEC, DECODER, RP RECEIVERS (Fig. 16, 17, 18)
Install by fitting the accessory cards so that their components side faces the inside of the 884 T control board.
Insert and remove the cards after cutting power.

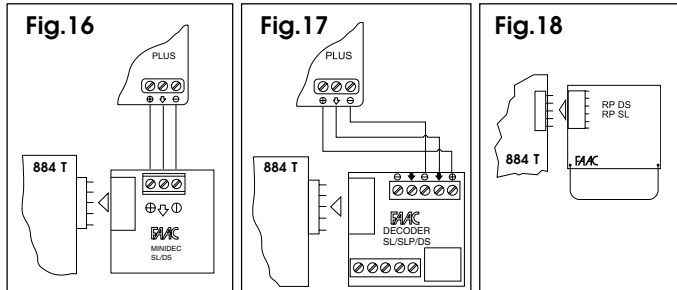

5.2.2. TERMINAL BOARD J2 (low voltage)

- 1 = OPEN A (N.O.) - Total opening**
This is any pulse generator with N.O. contact which, when activated, produces a gate opening movement. In A, E and S logics, it commands both opening and closing.
To install several Open A devices, connect N.O. contacts in parallel.
- 2 = OPEN B (N.O.) - Pedestrian Opening / Closing**
This is any pulse generator with N.O. contact which, when activated in A, E and S logics produces a gate opening movement for pedestrians. In B and C logics, it commands a closing movement.
To install several Open B devices, connect N.O. contacts in parallel.
- 3 = STOP command (N.C.)**
This is any device (e.g. a push-button) which, by opening a contact, stops gate movement.
To install several stop devices, connect the N.C. contacts in series.
⇒ If Stop devices are not connected, jumper the input to the common (terminal 5).
- 4 = FSW closing safety devices contact (N.C.)**
Safety devices are all devices (photocells, sensitive edges, magnetic loops) with N.C. contact, which, if there is an obstacle in the area they protect, operate to interrupt gate movement. The purpose of the closing safety devices is to protect the gate movement area during closing.
If the safety devices are tripped during closing, gate movement is reversed, whereas they have no effect during opening. If engaged when the gate is open or pausing, closing safety devices prevent its closing.
To install several safety devices, connect the N.C. contacts in series.
⇒ If closing safety devices are not connected, jumper this input to the common (terminal 5).

- 5 = Common for commands**
- 6 = Common for powering accessories**
- 7 = Positive pole for powering 24 Vdc (+) accessories**
Max load of accessories is 500 mA.
To calculate absorption values, refer to the instructions for individual accessories.

- 9 = Uscita lampada spia (Warning Light) 24 Vac**
Il carico massimo della lampada spia è di 5W.
For instructions on operation of the indicator-light, consult microswitch programming.
⇒ If you cut out jumper LK1, you obtain a free contact between terminals 8 and 9 (see fig. 19).

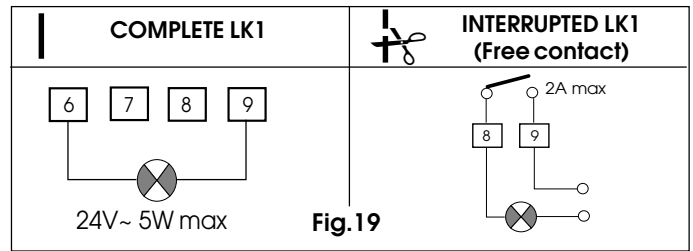

- 11 = Limit-switch common**
- 12 = Opening limit-switch (N.O.)**
- 13 = Closing limit-switch (N.O.)**

5.2.3. TERMINAL BOARD J3 (high voltage)

Terminal board for connecting flashing lamp (max 60W).

5.2.4. MORSETTIERA J4 (alta tensione)

Morsettiera per il collegamento del motore. Modificare i ponticelli di collegamento motore (situati nella scatola di derivazione sul lato destro del motore elettrico) in rapporto alla tensione di alimentazione usata (vedi fig. 14 e 15).

5.2.5. MORSETTIERA J5 (alta tensione)

Morsettiera per l'alimentazione 400V 3ph + Neutro - 50 Hz (vedi fig. 14) oppure 230V 3ph - 50 Hz (vedi fig. 15).
Collegare il cavo giallo/verde di terra come in Fig. 20.

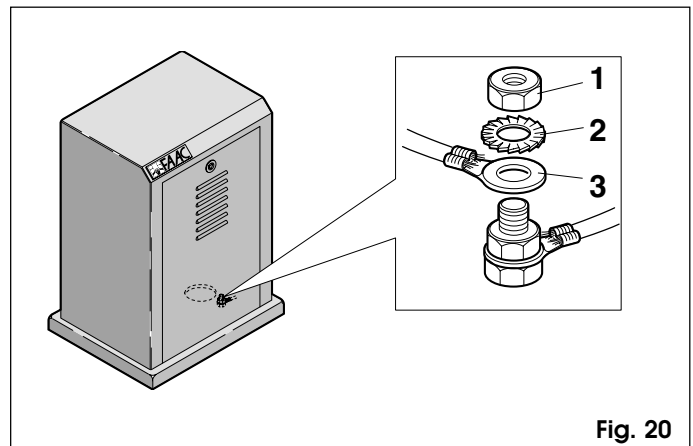

5.2.6. SIGNALLING LEDs

6 LEDs are fitted on the board, indicating status of terminal board inputs:

- LED LIGHTED** = contact closed
- LED OFF** = contact open

TAB. 4 STATUS OF LEDS

LED	LIGHTED	OFF
OPEN A	command active	command inactive
OPEN B	command active	command inactive
STOP	command inactive	command active
FSW	safety devices not engaged	safety devices engaged
FCC	closing limit-switch free	closing limit-switch engaged
FCA	opening limit-switch free	opening limit-switch engaged

5.3. PROGRAMMING

To program operation of the automated system, use the microswitches as shown below.

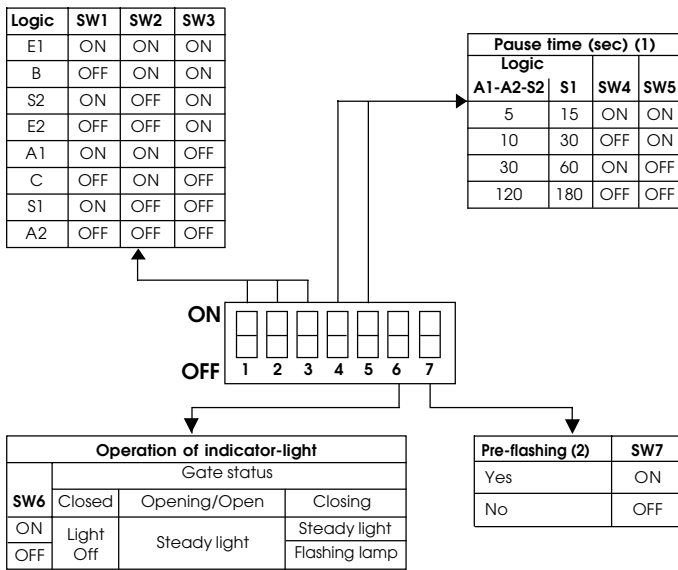

- (1) Pause times include pre-flashing if any
- (2) Pre-flashing begins 5" before every movement.

➔ **You must press the RESET push-button after every programming job.**

Function logics

The following are available:

A1/A2 = "Automatic" S1/S2 = "Safety device"
 E1/E2/B = "Semi-automatic" C = "Dead man"

Operation of the automated system in the different logics is indicated in Tables 5-6-7-8-9-10-11-12.

Pause time

Pause time is waiting time during opening before re-closing when an automatic logic was selected. Pause times include pre-flashing if any

Operation of indicator-light

Used to change the behaviour of the indicator-light at closing by making it flash.

Pre-flashing

Flashing lamp pre-flashing time of 5 sec before any movement can be selected. This warns anyone near the gate that it is about to move.

TABLE 5 LOGIC A1 (AUTOMATIC)

LOGIC A1	PULSES		
GATE STATUS	OPEN A - OPEN B (1)	STOP	SAFETY DEVICES
CLOSED	opens and re-closes after pause time (2)	no effect	no effect
OPEN IN PAUSE	re-closes after 5" (3)	stops the count	freezes pause until disengagement
CLOSING	reverses motion	stops	reverses motion
OPENING	no effect	stops	no effect
STOPPED	re-closes (2)	no effect	no effect

TABLE 6 LOGIC A2 (AUTOMATICA PLUS)

LOGIC A2	PULSES		
GATE STATUS	OPEN A - OPEN B (1)	STOP	SAFETY DEVICES
CLOSED	opens and re-closes after pause time (2)	no effect	no effect
OPEN IN PAUSE	re-closes after 5" (3)	stops the count	when disengaged, re-closes after 5"
CLOSING	reverses motion	stops	stops and reverses at disengagement (2)
OPENING	no effect	stops	no effect
STOPPED	re-closes (2)	no effect	no effect

TABLE 7 LOGIC S1 (SAFETY DEVICE)

LOGIC S1	PULSES		
GATE STATUS	OPEN A - OPEN B (1)	STOP	SAFETY DEVICES
CLOSED	opens and re-closes after pause time (2)	no effect	no effect
OPEN IN PAUSE	closes immediately (2-3)	stops the count	when disengaged, re-closes after 5"
CLOSING	reverses motion	stops	reverses motion
OPENING	reverses motion	stops	no effect
STOPPED	re-closes (2)	no effect	no effect

TABLE 8 LOGIC S2 (SAFETY DEVICE PLUS)

LOGIC S2	PULSES		
GATE STATUS	OPEN A - OPEN B (1)	STOP	SAFETY DEVICES
CLOSED	opens and re-closes after pause time (2)	no effect	no effect
OPEN IN PAUSE	re-closes immediately (2-3)	stops the count	freezes pause until disengagement
CLOSING	reverses motion	stops	stops and reverses at disengagement (2)
OPENING	reverses motion	stops	no effect
STOPPED	re-closes (2)	no effect	no effect

TABLE 9 LOGIC E1 (SEMI-AUTOMATIC)

LOGIC E1	PULSES		
GATE STATUS	OPEN A - OPEN B (1)	STOP	SAFETY DEVICES
CLOSED	opens (2)	no effect	no effect
OPEN	re-closes (2)	no effect	no effect
CLOSING	reverses motion	stops	reverses motion
OPENING	stops	stops	no effect
STOPPED	re-closes (when safety devices are engaged, it re-opens) (2)	no effect	no effect

TABLE 10 LOGIC E2 (SEMI-AUTOMATIC PLUS)

LOGIC E2	PULSES		
GATE STATUS	OPEN A - OPEN B (1)	STOP	SAFETY DEVICES
CLOSED	opens (2)	no effect	no effect
OPEN	re-closes (2)	no effect	no effect
CLOSING	reverses motion	stops	stops and reverses at disengagement (2)
OPENING	stops	stops	no effect
STOPPED	re-closes (when safety devices are engaged, it re-opens) (2)	no effect	no effect

TABLE 11 LOGIC B (SEMI-AUTOMATIC)

LOGIC B	PULSES			
GATE STATUS	OPEN A	OPEN B (4)	SAFETY DEVICES	STOP
CLOSED	opens (2)	no effect	no effect	no effect
OPEN	no effect	closes(2)	prevents closing	no effect
CLOSING	no effect	no effect	stops movement	stops movement
OPENING	no effect	no effect	no effect	stops movement
STOPPED	completes opening (2)	completes closing (2)	prevents closing	no effect

TABLE 12 LOGIC C (DEAD-MAN)

LOGIC C	CONTROLS HELD DOWN CONTINUOUSLY		PULSES	
	OPEN A (5)	OPEN B (4 and 5)	SAFETY DEVICES	STOP
CLOSED	opens	no effect	no effect	no effect
OPEN	no effect	closes	prevents closing	no effect
CLOSING	no effect		stops movement	stops movement
OPENING		no effect	no effect	stops movement
STOPPED	completes opening	completes closing	prevents closing	no effect

- (1) OPEN B input controls partial opening.
- (2) With pre-flashing selected, movement begins after 5 sec.
- (3) If the pulse is sent during pre-flashing, counting is restarted.
- (4) OPEN B input controls closing.
- (5) Push-button must be kept pressed to activate gate movement. When the push-button is released, the gate stops.

5.4. FAULT CONDITIONS

The following conditions cause certain effects to normal operation of the automated system:

- ① microprocessor error
 - ② safety electronic timing tripped (operation is interrupted if continuous work time exceeds 255 sec.).
 - ③ limit- switches disconnected (or both engaged)
- Conditions ① and ② cause the automated system to stop and nothing more.
 - Condition ③ causes an alarm situation disabling any activity: Normal operation can be restored only after eliminating the alarm cause and pressing the RESET push-button (or turning off power supply momentarily). To have this condition signalled, the indicator- light must be connected: the alarm is signalled by very rapidly flashing light (0.25 sec).

5.5. POSITIONING LIMIT-SWITCH PLATES

The 884 operator has an electro-mechanical limit-switch with roller and lever, which controls gate movement to stop when a profiled plate, secured on the top of the rack, activates the lever until the microswitch is tripped (fig. 21).

Procedure for correct positioning of the two limit-switch plates supplied:

- 1) Power up the system.
 - 2) Manually take the gate toward opening position, but leave it 5 cm from the required opening position.
 - 3) Allow the plate to slide over the rack in opening direction. As soon as the FCA limit-switch LED on the 884 T control board (fig. 13) goes off, move the plate a further 10 mm and secure it provisionally on the rack by two weld spots.
 - 4) Manually take the gate to closing position, leave it 5 cm from the limit stop.
 - 5) Allow the plate to slide over the rack in closing direction. As soon as the FCC limit-switch LED on the 884 T control board (fig. 13) goes off, move the plate a further 10 mm and secure it provisionally on the rack by two weld spots.
- Note: The plates are designed for securing with screws (fig. 21) if necessary.

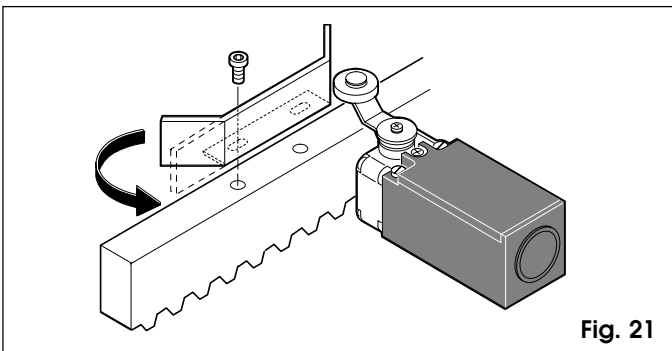

Fig. 21

The securing slot allows you to finely locate the limit-switch position.

- Important :**
- a) The plate must activate the limit-switch on the profiled part as shown in figure 21.
 - b) To prevent the plate from going beyond the limit-switch (long braking), we advise you to straighten the final profiled part as shown in fig.21.

6) Re-lock the system (see Chapter 8).

Important: to prevent damage to the operator and/or interrupting operation of the automated system, allow a clearance of about 5cm between the limit-switch tripping position and the required closing position.

5.6. LIMIT-SWITCH CONNECTION CHECK

Manually take the gate toward opening position, and check if, with the leaf open, the FCC LED is lighted and the FCA LED is off. Manually take the gate toward closing position, and check if, with the leaf closed, the FCA LED is lighted and the FCC LED is off.

If the LEDs are inverted, changeover the cables connected to terminals 12 and 13.

5.7. ROTATION DIRECTION CHECK

- 1) Release the operator, take it manually to mid-travel and re-lock it (see Chapter 7 - 8).
- 2) Power up the system and then press the RESET push-button.
- 3) Give an Open command to the operator, check if the gate moves in opening direction and then press the RESET push-button to stop the leaf moving.
- 4) If rotation direction is incorrect, changeover wiring of cables T1 and T3 of the electric motor.

5.8. SETTING THE MECHANICAL CLUTCH

To calibrate the transmitted torque adjustment system, refer to fig. 22.

Remove the safety lid and the lock nut. Adjust the clutch using a socket wrench (fig. 22).

Turn the nut clockwise to increase torque.

Turn the nut anticlockwise to decrease torque.

Activate the operator and check that the clutch is set to allow the leaf to slide without being too dangerous.

Refit the lock nut and the safety lid.

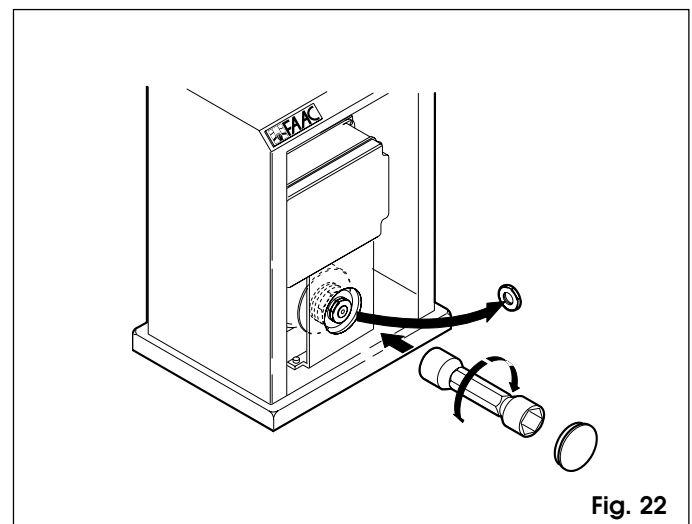
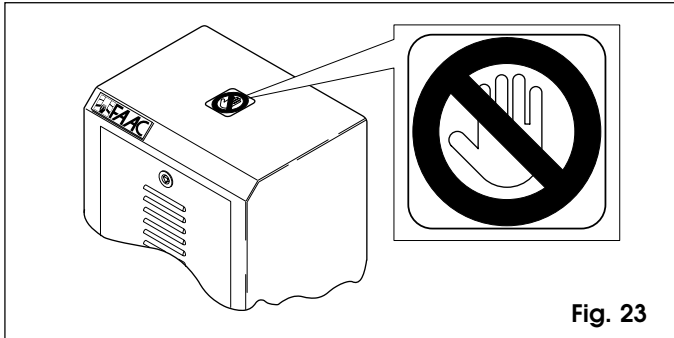

Fig. 22

6. TESTING THE AUTOMATION

When installation is complete, affix the danger warning label to the top of the casing (Fig. 23). Thoroughly check operation of the automation and all connected accessories.



Give the customer the User's Guide. Explain correct use and operation of the gear motor and draw attention to the potential danger zones of the automation.

7. MANUAL OPERATION

If the gate has to be operated manually due to a power failure or malfunction of the automation, use the release device as follows.

- Open the door in the casing using the triangular key provided (see fig. 24).
- Operate the release lever shown in fig. 25 (pos. MANUAL).
- A safety microswitch in the release system prevents the automation from being activated by accidental commands (7, fig. 2).
- Close the door and open or close the gate manually.

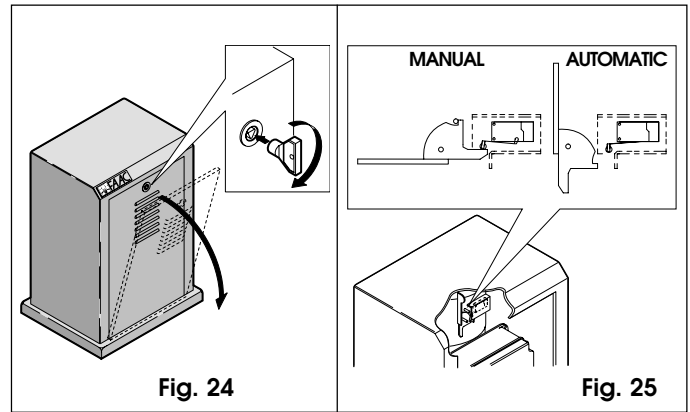

8. RETURN TO NORMAL OPERATION

- Open the door in the casing using the triangular key provided (see fig. 24).
- Move back the lever shown in fig. 25 up to the mechanical stop (pos. AUTOMATIC).
- Close the door.

9. MAINTENANCE

When performing maintenance always check that the anti-crushing clutch is correctly regulated and that the safety devices operate correctly.

10. REPAIRS

For repairs contact an authorised FAAC Repair Centre.

USER'S GUIDE

AUTOMATION 884

Read the instructions carefully before using the product and keep them for future reference.

GENERAL SAFETY INSTRUCTIONS

If correctly installed and operated, the 884 automations ensure a high level of safety.

However, some simple rules should be followed to avoid accidents:

- Do not stand in the vicinity of the automation or allow anyone else, especially children, to do so and do not place objects in the vicinity of the automation. This is particularly important during operation.
- Keep remote controls and other control devices out of the reach of children to prevent them from accidentally operating the automation.
- Do not allow children to play with the automation.
- Do not deliberately obstruct the movement of the gate.
- Make sure that branches or bushes do not interfere with the movement of the gate.
- Keep the luminous signalling systems efficient and clearly visible.
- Do not attempt to operate the gate manually without first releasing it.
- In the event of a malfunction, release the gate to allow access and call a qualified technician for service.
- After setting manual operation, disconnect the electricity supply from the system before returning to normal operation.
- Do not make any modifications to components belonging to the automation system.
- Do not attempt to perform any repair work or tamper with the automation. Call FAAC qualified personnel for repairs.
- At least once every six months have the automation, the safety devices and the earth connection checked by a qualified technician.

DESCRIPTION

The FAAC 884 automation is ideal for controlling industrial vehicle access areas.

The 884 for sliding gates is an electromechanical operator which transmits movement to the leaf by means of a pinion with rack or chain coupled in an appropriate manner to the sliding gate.

If automatic operation has been selected, sending an impulse causes the gate to reclose on its own after the selected pause time.

If semiautomatic operation has been selected, a second impulse must be sent to reclose the gate.

An opening impulse sent while the gate is reclosing causes it to change direction of movement.

A stop command (if available) stops movement at any time. For detailed information on operation of the sliding gate in the various operating modes, contact the installation technician.

The automations have safety devices (photocells) which prevent the gate from reclosing when an obstacle lies within the area they are protecting.

The system ensures mechanical locking when the motor is not in operation, so it is not necessary to install a lock.

The gear motors have an adjustable mechanical clutch for safe use of the automation.

The electronic control unit is incorporated in the gear motor.

A convenient manual release device allows the gate to be

operated in the event of a power failure or malfunction. The light flashes while the gate is moving.

MANUAL OPERATION

If the gate has to be operated manually due to a power failure or malfunction of the automation, use the release device as follows:

- Open the door in the casing using the triangular key provided (see Fig. 1).
- Operate the release lever shown in fig. 2 (pos. MANUAL).
- A safety microswitch in the release system prevents the automation from being activated by accidental commands .
- Close the door and open or close the gate manually.

RETURN TO NORMAL OPERATION

- Open the door in the casing using the triangular key provided (see Fig. 1).
- Move back the lever shown in fig. 2 up to the mechanical stop (pos. AUTOMATIC).
- Close the door.

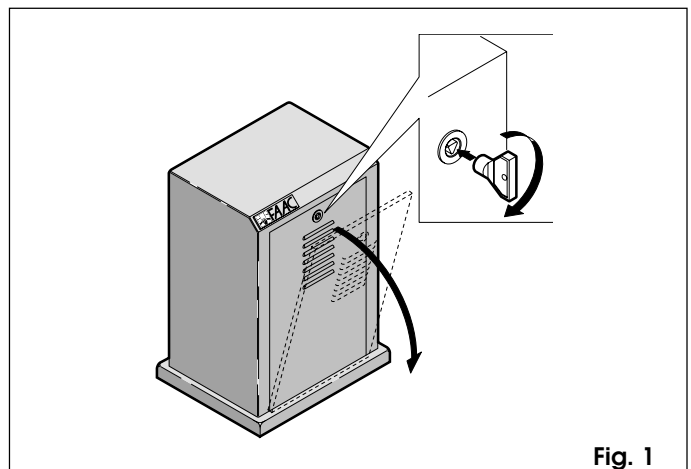

Fig. 1

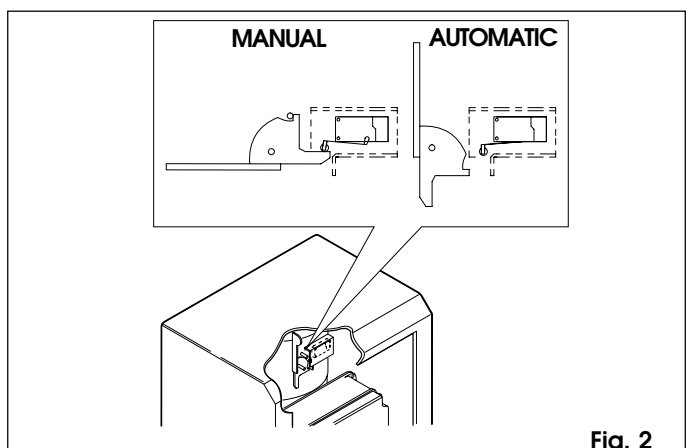

Fig. 2