

## CE DECLARATION OF MACHINE CONFORMITY

(DIRECTIVE 89/392/EEC, ANNEX II, PART B)

**Manufacturer :** FAAC S.p.A.

**Address:** Via Benini, 1 - 40069 Zola Predosa BOLOGNA - ITALY

**Declares that:** Operator mod. 748 with electronic control unit 748D,

- is manufactured to be incorporated in a machine or for assembly with other machines to constitute a machine under the provisions of Directive 89/392/EEC, and subsequent amendments 91/368/EEC, 93/44/EEC, 93/68/EEC;
- conforms to the essential safety requirements of the following further EEC Directives:

73/23/EEC and subsequent amendment 93/68/EEC.  
89/336/EEC and subsequent amendment 92/31/EEC and 93/68/EEC

and, furthermore, declares that putting the machine into service is forbidden until the machine in which it will be incorporated or of which it will become a part has been identified and it has been declared as conforming to the conditions of Directive 89/392/EEC and subsequent amendments enacted by the national implementing legislation.

Bologna, 01 January 2002

The Managing Director  
A. Bassi



## WARNING FOR THE INSTALLER

### GENERAL SAFETY OBLIGATIONS

- CAUTION! It is important for personal safety to follow all the instructions carefully. Incorrect installation or misuse of the product may cause people serious harm.**
- Read the instructions carefully before starting to install the product.
- Packaging material (plastic, polystyrene, etc.) must not be left within reach of children as it is a potential source of danger.
- Keep the instructions in a safe place for future reference.
- This product was designed and manufactured strictly for the use indicated in this documentation. Any other not expressly indicated use may damage the product and/or be a source of danger.
- FAAC accepts no responsibility due to improper use of the automation or use other than that intended.
- Do not install the appliance in an area subject to explosion hazard: inflammable gasses or fumes are a serious safety hazard.
- The system must be constructed in compliance with the following Standards: EN12604, EN12605, EN12453, EN12445.  
For non-EU countries, to obtain an adequate level of safety, the Standards mentioned above must be observed, in addition to national legal regulations.
- FAAC will not accept responsibility if the principles of good workmanship are disregarded in constructing the closing elements to be motorised, and if any deformation occurs during use of the said elements.
- Before carrying out any work on the system, switch off the electricity supply.
- The mains electricity supply of the automation must be fitted with a single-pole switch with contact opening distance of 3mm or greater. Use of a 6A thermal breaker with single-pole circuit break is recommended.
- Make sure there is a differential switch with 0.03A threshold upstream of the system.
- Check that the earthing system is correctly made and connect the closure metal parts to it. Also connect the Yellow/Green wire of the automation to the earthing system.
- The automation includes an intrinsic anti-crushing device consisting of a torque control which, however, must be installed together with other safety devices.
- The safety devices (e.g.: photocells, sensitive edges, etc...) protect any dangerous areas against **Movement mechanical risks**, such as, crushing, dragging, or shearing.
- Use of at least one indicator-light is essential for each system (e.g.: FAAC LAMP MINILAMP, etc.) as well as a sign adequately fixed to the frame structure, in addition to the devices mentioned at point "16".
- FAAC accepts no responsibility regarding safety and correct operation of the automation, should components made by manufacturers other than FAAC be used in the system.
- Use only FAAC original spare parts for maintenance.
- Do not make any alterations to the components of the automation.
- The installer must supply full information regarding manual operation of the system in the event of an emergency and provide the user of the system with the "User's Guide" included with the product.
- Do not allow children or other persons to stand near the product while in operation.
- Keep remote controls or any other pulse generator well away from children, to prevent the automation from being activated accidentally.
- The user must refrain from attempting to repair or adjust the system personally and should contact qualified personnel only.
- Anything not expressly provided for in these instructions is not permitted.**

# 748 AUTOMATION SYSTEM

The FAAC 748 automation system for sliding residential gates is an electromechanical operator that transmits the leaf movement by means of a pinion coupled to a rack fixed to the gate. The irreversible system locks mechanically when the motor is not running, so it is not necessary to install a lock.

## 1. DESCRIPTION AND TECHNICAL SPECIFICATIONS

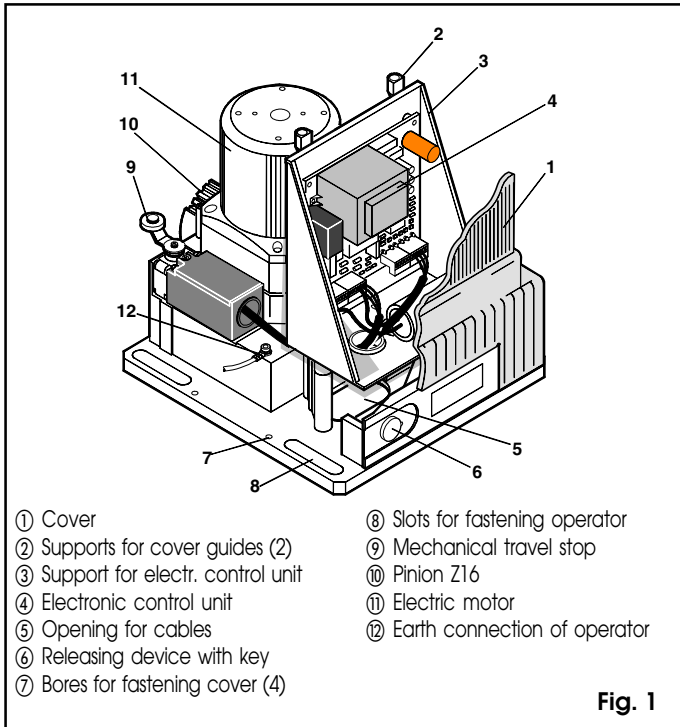

**Table 1: Technical specifications of 748 115Vac and 230Vac Operator**

Model	748-115V	748-230V
Power supply Vac(+6-10%) 50Hz	115	230
Absorbed power (W)	600	350
Current drawn (A)	5	1.6
Electric motor	4 poles - 1400rpm	4 poles - 1400 rpm
Surge capacitor	30µF/450V	10µF/450V
Reduction ratio	1:25	
Pinion	Z16	
Rack	module 4 - pitch 12.566	
Max. torque (Nm)	15	
Max. thrust (daN)	45 (Z16)	
Thermal cutout on winding	140°C	
Duty cycle	(see paragraph 1.1)	
Temperature range (°C)	-20 ÷ +55 °C	
Weight of operator (Kg)	10	
Housing protection	IP 44	
Max. gate weight (Kg)	300	
Gate speed (m/min)	12 (Z16)	

### 1.1. MAXIMUM DUTY CYCLE CURVE

The curve makes it possible to determine the maximum operating time (T) as a function of the duty cycle (F), e.g., the 748 operator can work continuously at a duty cycle of 25%.

To ensure smooth running, operation should be kept within the duty area below the curve.

*Important:* the curve was plotted on the basis of operation at 24 °C. Allow for up to 20% reduction of duty cycle in case of exposure to direct sunlight.

### Calculating the duty cycle

The duty cycle is the proportion of the actual operating time (opening + closing) with respect to the total time of the cycle (opening + closing + pause time).

The formula for calculating it is the following:

$$\%F = \frac{T_o + T_c}{T_o + T_c + T_p + T_i} \times 100$$

where:

- T<sub>o</sub> = opening time;
- T<sub>c</sub> = closing time;
- T<sub>p</sub> = pause time;
- T<sub>i</sub> = duration of interval between a complete cycle and the next one.

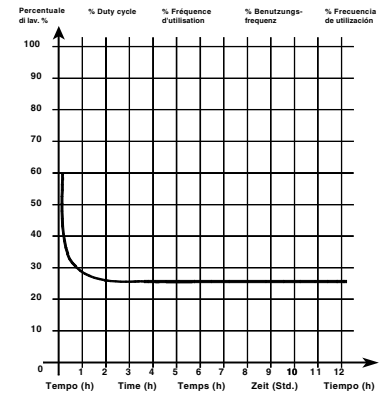

## 2. STANDARD INSTALLATION LAYOUT

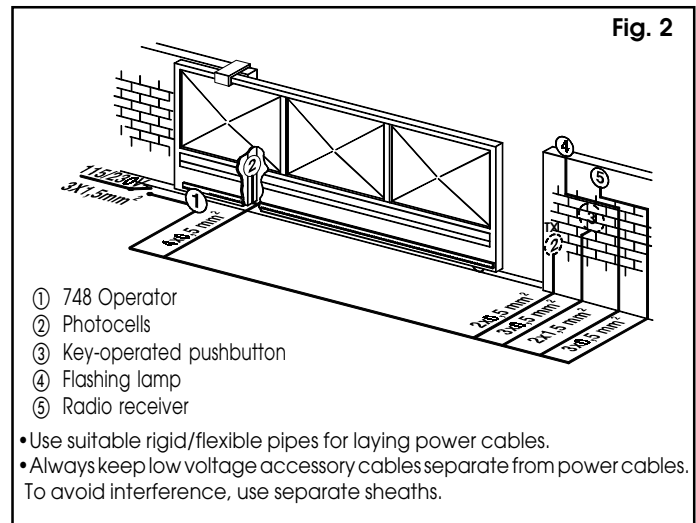

## 3. INSTALLATION OF AUTOMATION SYSTEM

### 3.1. PRELIMINARY CHECKS

To ensure trouble-free operation, make sure that the gate (whether existing or yet to be installed) has the following specifications:

- Max. gate weight 300kg.
- Strong and rigid leaf frame.
- Flat leaf face, with no protruding parts and no vertical members.
- Smooth and even movement of the gate over its entire travel.
- No sideways oscillation of the leaf.
- Upper and lower sliding system in perfect conditions. The use of floor tracking with a rounded channel is preferable to reduce friction in the sliding movement.
- Only two side wheels.
- **Mechanical safety stops to avoid risk of derailment. These stops must be firmly fixed to the ground or to the floor track, about 2 cm beyond the travel limit.**
- No mechanical locks.

If any welding or brazing is required on the gate, it should be done before installing the automation system.

The condition of the structure directly affects the reliability and safety of the automation system.

### 3.2. INSTALLING THE OPERATOR

1) Dig out a hole for the base plate as shown in fig. 3.

In order to ensure the correct engaging of the pinion and rack, the base plate must be placed in the position shown in fig. 4a (right closing) or 4b (left closing).

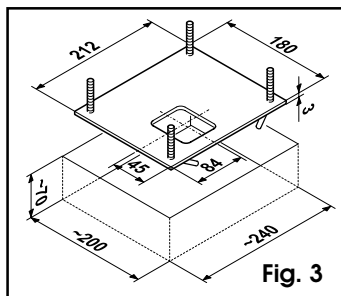

Fig. 3

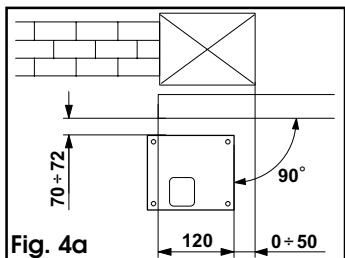

Fig. 4a

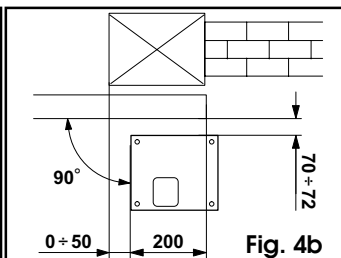

Fig. 4b

*N.B.* it is advisable to place the base plate on a concrete foundation at about 50 mm from the ground (fig. 5).

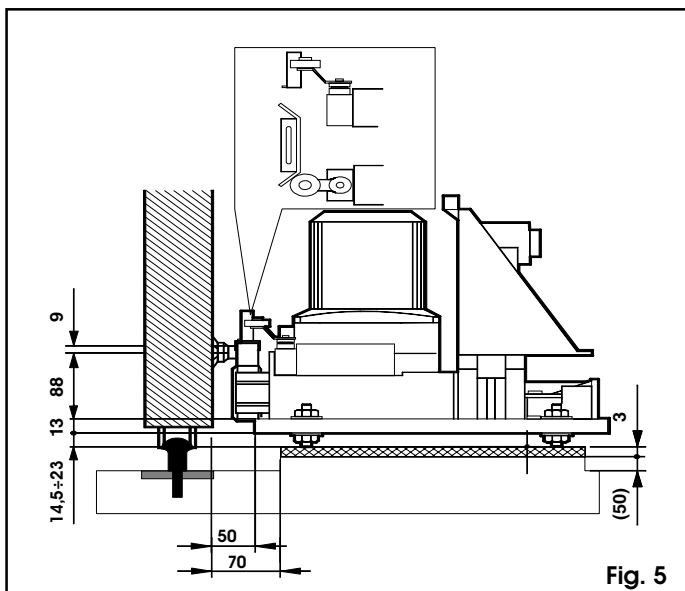

Fig. 5

2) Lay the flexible pipes for connection cables between operator, accessories, and power supply. The flexible pipes must protrude by approximately 3 cm from the opening on the plate (fig. 3).

3) Cement in the plate, ensuring that it is perfectly level.

4) Wait for the concrete to set in the hole.

5) Lay the cables for connection with accessories and power supply. To facilitate the electrical wiring on the electronic unit, about 30 cm of cable should come out of the opening on the base plate.

6) Fasten the operator to the base plate by means of the screws and washers supplied, as shown in fig. 6.

The positioning of the operator is shown in fig. 5.

Pass the electrical cables through the relevant opening (fig. 1 - ref. 5) on the base of the operator.

7) Pass the electrical connection cables through the relevant opening on the base of the electronic control unit support (fig. 1 - ref. 3), using the cable clamp supplied.

8) Connect up the cables to the electronic control unit.

*Important:* connect up the earth cable of the system to the position shown in fig. 1 - ref. 12.

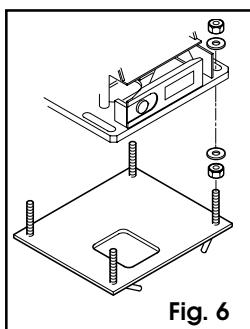

Fig. 6

### 3.3. ASSEMBLING THE RACK

1) Fit the rack by means of the screws TE 8x25 and the spacers provided, as shown in figure 7.

To avoid welding to the gate, galvanized passing spacers with screws TE 8x50 are provided.

*N.B.* it is advisable to tighten the rack fixing screws at the top of the slot. This allows the rack to be raised if, with time, the gate tends to sink.

2) Release the operator (see paragraph 3.5).

3) Slide the gate leaf open, by hand.

4) Place the first section of the rack on the pinion, aligning the latter with the first spacer (fig. 8).

5) Fix the rack section to the leaf by means of a clamp (fig. 8).

6) Slide the gate leaf by hand towards its closed position, until it is in line with the third spacer on the rack, and spot weld the spacer in position.

7) Completely weld the three spacers to the gate.

To fasten the other rack sections needed to reach the position of complete closing, proceed as follows:

8) Line up another rack section to the last one fixed to the gate. Use a section of rack of about 150 mm and ensure that the teeth are correctly spaced (fig. 9).

9) Slide the gate by hand towards its closed position until the third spacer of the section to be fastened is aligned with the pinion (fig. 9).

*N.B.* ensure that all the rack sections are correctly centered on the pinion teeth. If not, adjust the position of the operator.

10) Weld the three spacers of the section (fig. 9).

*Caution:*

- a) do not weld the rack sections to the spacers or to each other;
- b) do not use grease or other lubricants on the pinion and rack.

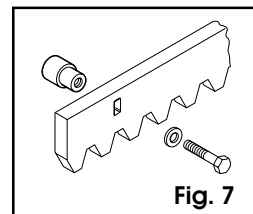

Fig. 7

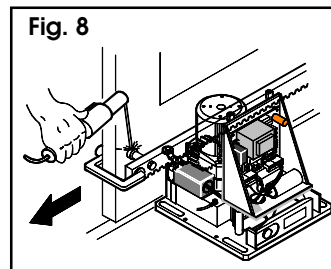

Fig. 8

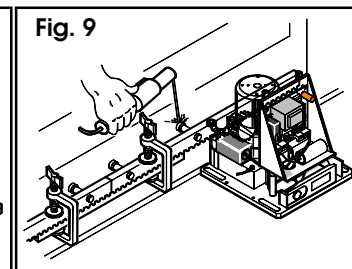

Fig. 9

11) To obtain a correct slack between the pinion and rack, lower the operator by 1.5 mm, by means of the support nuts of the base plate (fig. 10).

When this adjustment has been completed, tighten the screws that fasten the operator.

*Caution:* if the gate is new, check the slack (fig. 11) after a few months.

12) Manually check whether the gate can open completely and the movement of the leaf is smooth and even, over its entire travel.

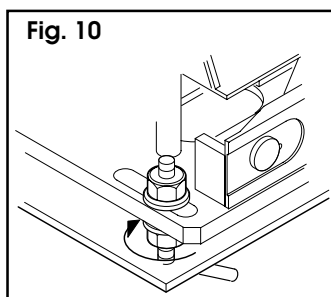

Fig. 10

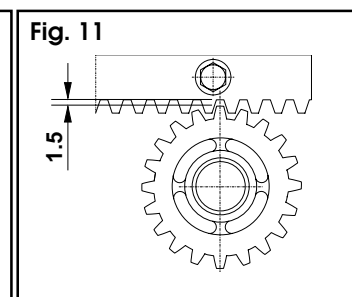

Fig. 11

### 3.4. POSITIONING TRAVEL LIMIT PLATES

The 748 operator is equipped with an electro-mechanical travel limit switch with roller, which, when a profiled plate secured at the top of the rack activates its lever, commands the gate movement to slow down and stop. Procedure for correct positioning of the two travel limit plates supplied:

- 1) Power up the system.
- 2) Manually take the gate to opening position, leaving a space of 2 cm from the mechanical travel limit stop position.
- 3) Slide the plate along the rack in opening direction and check if the switch is activated before the end of the profiled part (the FCA LED on the 748D equipment goes OFF).
- 4) Allow the plate to advance further until the switch wheel is about 2-3 cm from the end of the plate's straight area and secure it provisionally.
- 5) Manually take the gate to closing position, leaving a space of 2 cm from the mechanical stop.
- 6) Slide the plate along the rack in closing direction and check if the switch is activated before the end of the profiled part (the FCC LED on the 748D equipment goes OFF).
- 7) Allow the plate to advance further until the switch wheel is about 2-3 cm from the end of the plate's straight area and secure it provisionally.
- 8) When the slow-down and/or braking time (see instructions for the 748D equipment) has been programmed, it may be necessary to slightly correct the position of the plates, if the stop points are not as required. If this operation is performed, you must make sure that the gate never stops less than 2 cm from the mechanical travel limit stops and that the electro-mechanical travel limit wheel is at least 2 cm from the end of the plate's straight area; if necessary, adjust the slowing down time and/or straighten the final profiled part of the plate (see fig.12).
- 9) Re-lock the system. Important: before sending an opening or closing pulse, make sure that the gate cannot be moved manually.
- 10) Command a few complete cycles of the automated system, checking that the gate never reaches the mechanical travel limit stops.

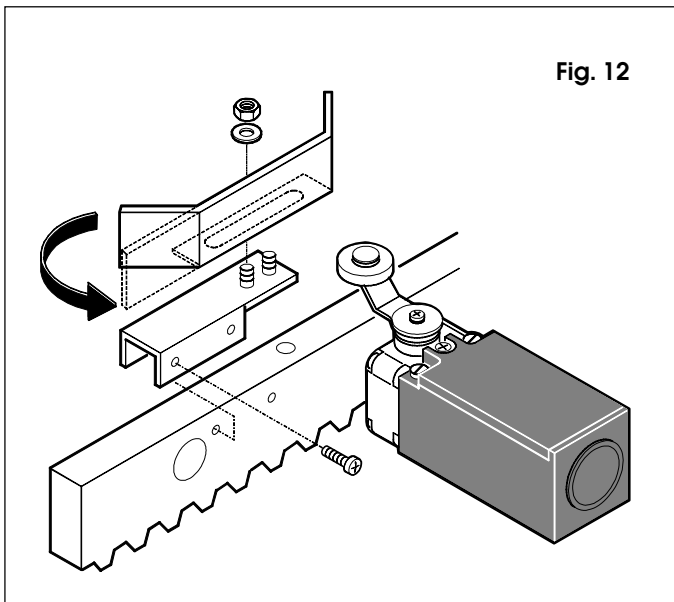

Fig. 12

### 3.5. MANUAL OPERATION

Should the need arise to operate the gate manually because of a power failure or malfunction, release it by means of the releasing device.

Proceed as follows:

- open the lid of the lock and insert the relative key in the lock (fig. 13);
- turn the key clockwise and open the cover of the releasing device as shown in figure 13.

To re-lock the system, return the cover of the releasing device to its initial position.

**Important:** before giving a signal, ensure that the gate cannot be moved manually.

**N.B.:** re-lock always the operator with gate in closed position.

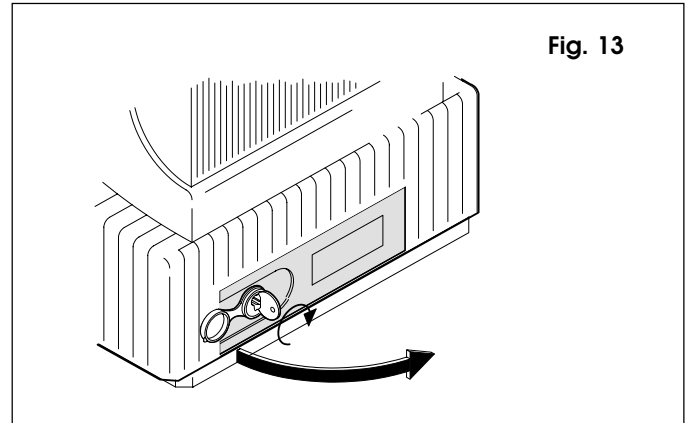

Fig. 13

### 4. START-UP

- 1) When you have carried out all the electrical connections, locked the operator, and checked that it cannot be moved by hand, power up the system.
- 2) Program the 748D equipment. Check the status of the equipment's inputs and verify if all safety devices are correctly connected (the relevant LEDs must be lighted).
- 3) Run a few complete cycles to check if the automated system and the accessories connected to it are operating correctly, giving special attention to safety devices and to the adjustment of the operator's thrust force.
- 4) Hand over the User's Guide to the customer, and describe how the system works, as well as the operator release and locking operations indicated in the said guide.

## USER'S GUIDE

### 748 AUTOMATION

**Read the instructions carefully before using the product and keep them for future reference.**

#### GENERAL SAFETY INSTRUCTIONS

The 748 automation, when installed and used correctly, affords a high level of safety.

However, some simple rules should be followed to avoid accidents:

- Do not stand in the vicinity of the automation or allow anyone else, especially children, to do so, and do not place objects in the vicinity of the automation. This is particularly important during operation.
- Keep remote controls or any other control devices out of the reach of children to prevent them from accidentally operating the automation.
- Do not allow children to play with the automation.
- Do not deliberately obstruct the movement of the gate.
- Make sure that branches or bushes do not interfere with the movement of the gate.
- Ensure that the signalling lights are efficient and clearly visible.
- Do not attempt to move the gate manually without first releasing it.
- In the event of a malfunction, release the gate to allow access and call a qualified technician for service.
- After setting manual operation, disconnect the electricity supply from the system before returning to normal operation.
- Do not make any modifications to components of the automation system.
- Do not attempt to perform any repair work or tamper with the automation. Call FAAC qualified personnel for repairs.
- At least once every six months have the automation, the safety devices and the earth connection checked by a qualified technician.

#### DESCRIPTION

The FAAC 748 automation is ideal for residential applications. The FAAC model 748 automation for sliding gates are electromechanical operators which transmit movement to the leaf by means of a pinion with rack coupled in appropriate manner to the sliding gate.

The operation of the sliding gate is controlled by an electronic control unit housed inside the operator.

When the gate is closed, on receipt of an opening impulse from a remote control or other suitable control device, the control unit will start the motor to move the gate to the open position.

If automatic operation has been selected, sending an impulse causes the gate to reclose on its own after the selected pause time.

If semiautomatic operation has been selected, a second impulse must be sent to reclose the gate.

A stop command (if available) stops movement at any time. For detailed information on operation of the sliding gate in the various operating modes, contact the installation technician.

The automations have safety devices (photocells) which prevent the gate from reclosing when an obstacle lies within the area they are protecting.

The system ensures mechanical locking when the motor is not in operation, so it is not necessary to install a lock.

For this reason the release system must be operated before the gate can be opened manually.

A convenient manual release device allows the gate to be operated in the event of a power failure or malfunction.

The light flashes while the gate is moving.

#### MANUAL OPERATION

Should the need arise to operate the gate manually because of a power failure or malfunction, release it by means of the releasing device.

Proceed as follows:

- open the lid of the lock and insert the relative key in the lock (fig. 1);
- turn the key clockwise and open the cover of the releasing device as shown in figure 1.

To re-lock the system, return the cover of the releasing device to its initial position.

*Important:* before giving a signal, ensure that the gate cannot be moved manually.

**N.B.: re-lock always the operator with gate in closed position.**

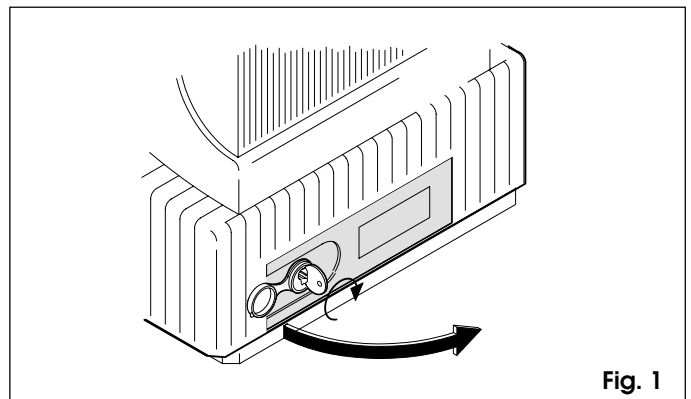

Fig. 1

# CONTROL BOARD 748D

## 1. WARNINGS

**Important:** Before attempting any work on the control board (connections, maintenance), always turn off power.

- Install, upstream of the system, a differential thermal breaker with adequate tripping threshold.
- Connect the earth cable to the appropriate terminal on the J7 connector of the equipment (see fig.2).
- Always separate power cables from control and safety cables (push-button, receiver, photocells, etc.). To avoid any electric noise, use separate sheaths or a shielded cable (with earthed shield).

## 2. TECHNICAL SPECIFICATIONS

Model	748D-115V	748D-230V	
Power supply	V~ (+6% -10%) 50 Hz	115	230
Absorbed power (W)	10	10	
Motor max. load (W)	1200	1000	
Accessories max. load (A)	0.5	0.5	
Operating ambient temperature	-20 °C +55 °C		
Protection fuses	2 (see fig. 1)		
Function logics	Automatic / "Stepped" automatic / Semi-automatic / Safety devices / Semi-automatic B / "Dead-man C / "Stepped" semi-automatic		
Work time	Programmable (from 0 to 4 min.)		
Pause time	Programmable (from 0 to 4 min.)		
Thrust force	Adjustable over 50 levels		
Terminal board inputs	Open / Partial opening / Safety devices at opng. / Safety devices at clsg. / Stop / Edge / Power supply + Earth		
On-connector inputs	Opening and closing limit-switches / Encoder		
Terminal board outputs	Flashing lamp - Motor - 24 Vdc accessories power supply - 24 Vdc indicator-light / Timed output. - Fail safe		
Rapid connector	5-pin card connection for Minidec, Decoder or RP receivers		
Programming	3 keys (+, -, F) and display, "basic" or "advanced" mode		
Basic mode programmable functions	Function logic - Pause time - Thrust Force - Gate direction		
Advanced mode programmable functions	Torque at initial thrust - Braking - Fail safe - Pre-flashing - Indicator-light/Timed output - Opening and closing safety devices logic - Encoder - Decelerations - Partial opening time - Work time - Assistance request - Cycle counter		

## 3. LAYOUT AND COMPONENTS

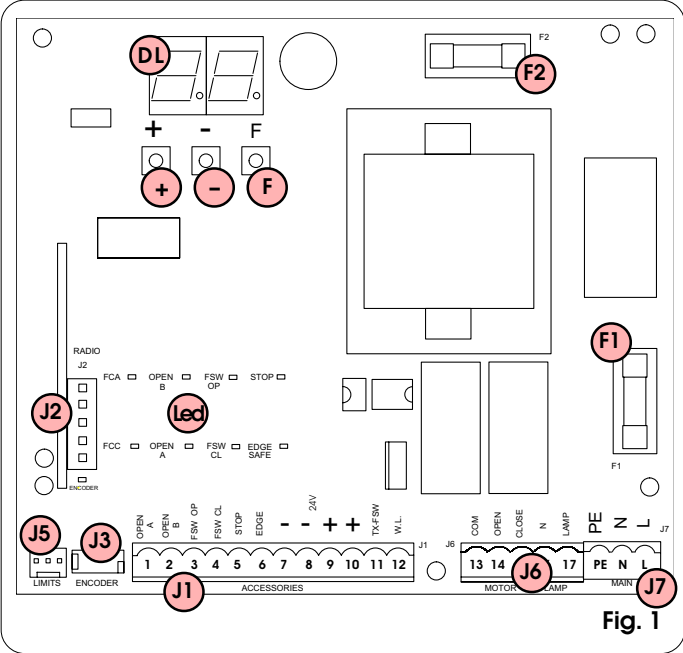

DL	SIGNALLING AND PROGRAMMING DISPLAY
Led	INPUTS STATUS CONTROLLED
J1	LOW VOLTAGE TERMINAL BOARD
J2	CONNECTOR FOR DECODER/MINIDEC/RP RECEIVER
J3	ENCODER CONNECTOR
J5	LIMIT-SWITCH CONNECTOR
J6	MOTORS AND FLASHING LAMP CONNECTION TERMINAL BOARD
J7	POWER SUPPLY TERMINAL BOARD 115V <sub>ac</sub> (748D-115V)-230V <sub>ac</sub> (748D-230V)
F1	MOTORS AND TRANSF. PRIMARY FUSE (748D115V=F10A-748D230V=F5A)
F2	LOW VOLTAGE AND ACCESSORIES FUSE (T 800mA)
F	"F" PROGRAMMING PUSH-BUTTON
-	"-" PROGRAMMING PUSH-BUTTON
+	"+" PROGRAMMING PUSH-BUTTON

## 4. ELECTRIC CONNECTIONS

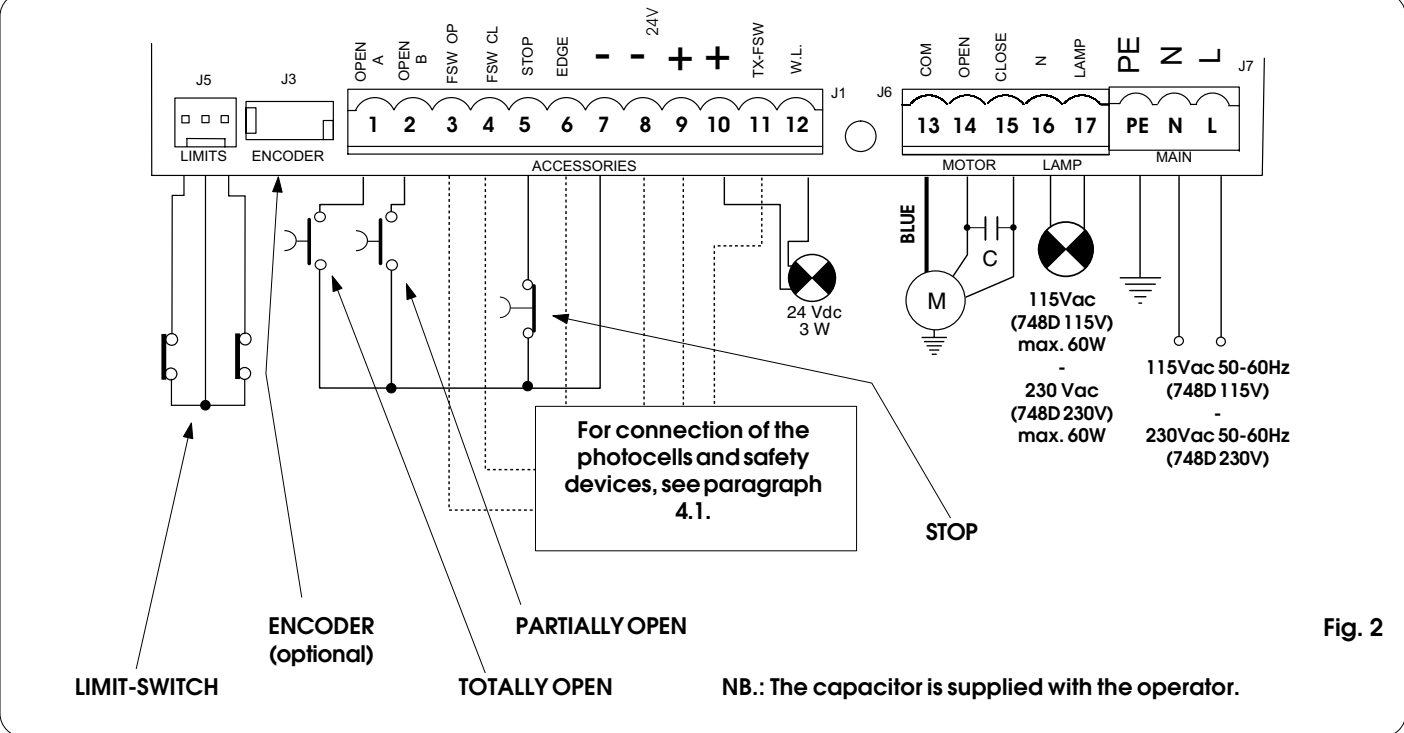

**4.1. Connection of photocells and safety devices**

Before connecting the photocells (or other devices) we advise you to select the type of operation according to the movement area they have to protect (see fig.3):

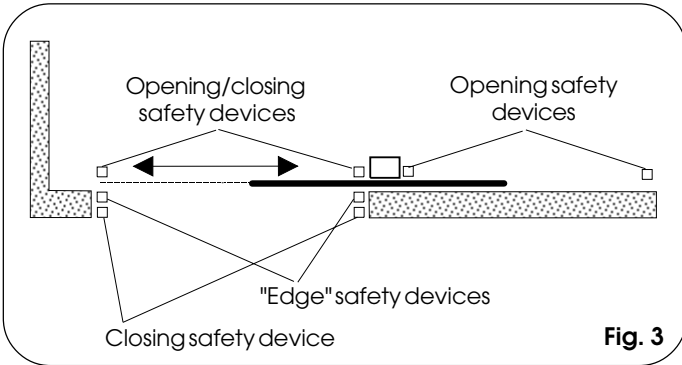

Fig. 3

**Opening safety devices:** they operate only during the gate opening movement and, therefore, they are suitable for protecting the area between the opening leaf and fixed obstacles (walls, etc) against the risk of impact and crushing.

**Closing safety devices:** they operate only during the gate closing movement and, therefore, they are suitable for protecting the closing area against the risk of impact.

**Opening/closing safety devices:** they operate during the gate opening and closing movements and, therefore, they are suitable for protecting the opening and closing areas against the risk of impact.

**"Edge" safety devices:** they operate during the gate opening and closing movements and, therefore, they are suitable for protecting the areas between the moving leaf and fixed obstacles (pillars, walls, etc) against the risk of shearing and dragging.

**Encoder (optional):** operates during the gate opening and closing movements and, therefore, it is suitable for protecting the opening and closing area against the risk of impact, crushing, shearing and dragging.

**N.B. If two or more safety devices have the same function (opening, closing, opening and closing, edge), the contacts must be connected to each other in series (fig. 4).**

**N.C. contacts must be used.**

Connection of two N.C. contacts in series  
(e.g. Photocells, Stop, Edge, etc.)

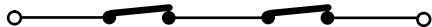

Fig. 4

**N.B. If safety devices are not used, jumper connect the terminals as shown in fig. 5.**

Connection of no safety device

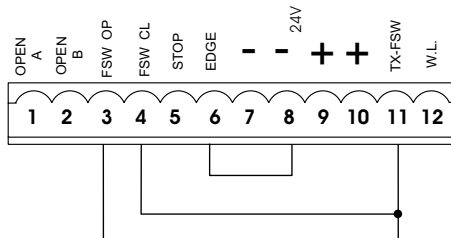

Fig. 5

The most common photocell and safety device lay-outs are shown below (from fig. 6 to fig. 13).

Connection of a closing safety device and an opening safety device

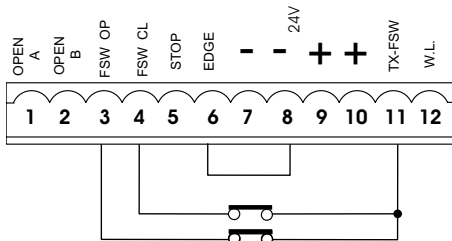

Fig. 6

Connection of an "edge" safety device

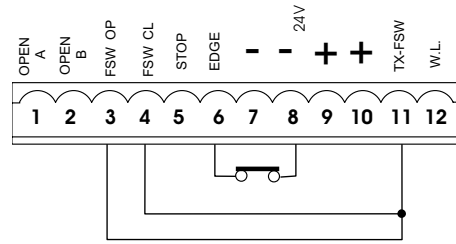

Fig. 7

Connection of a pair of photocells for opening

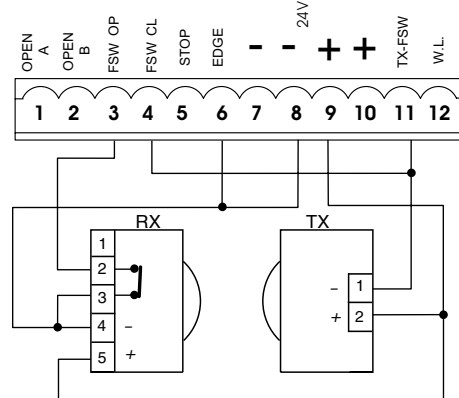

Fig. 8

Connection of a pair of closing photocells

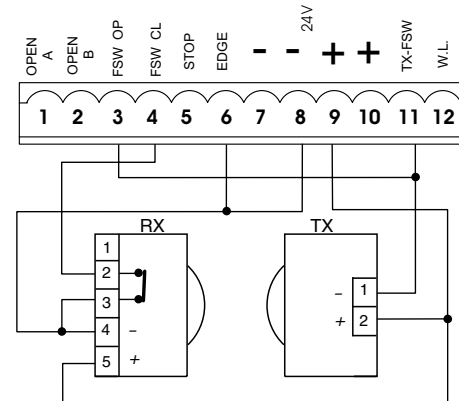

Fig. 9

Connection of a pair of opening photocells, a pair of closing photocell and an edge safety device

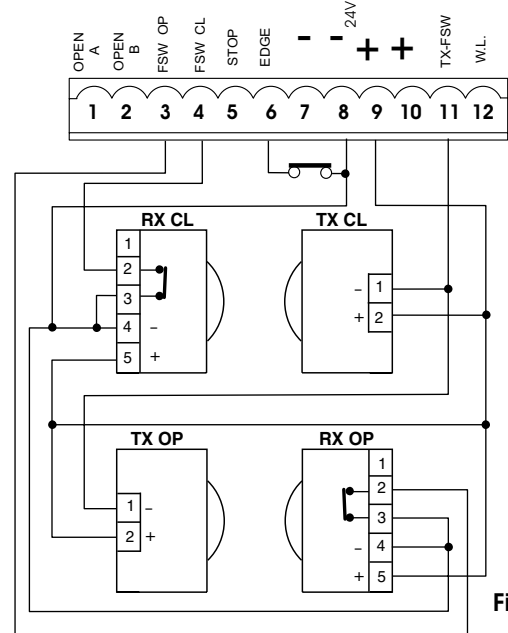

Fig. 10

Connection of two pairs of closing photocells and two edge safety devices

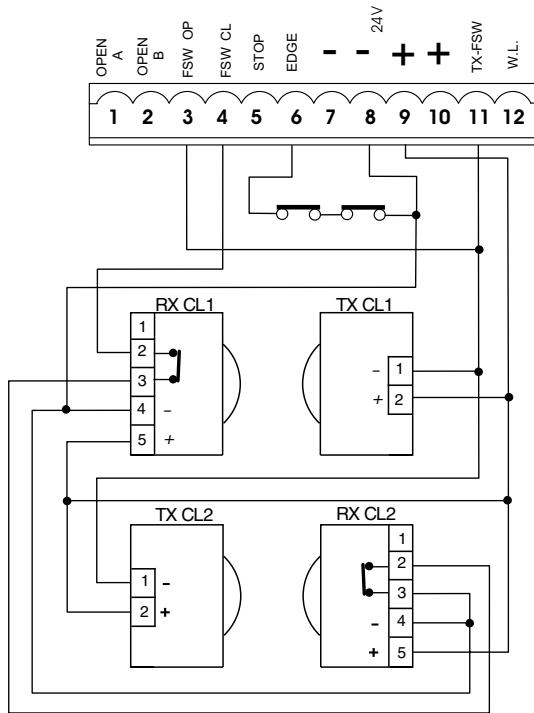

Fig. 11

Connection of a pair of closing photocells and a pair of opening/closing photocells

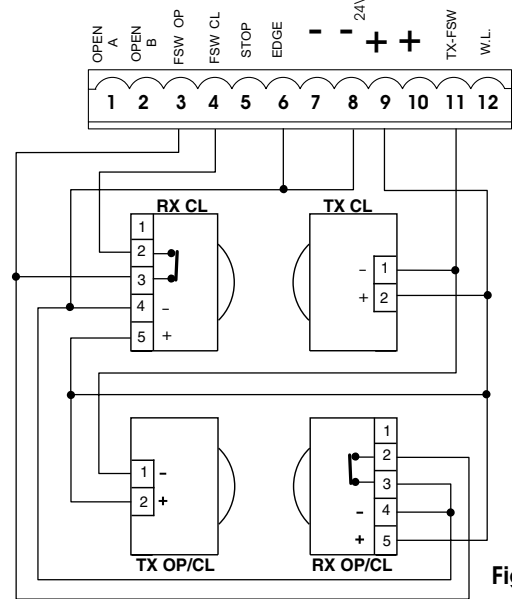

Fig. 13

Connection of a pair of closing photocells, a pair of opening photocells and a pair of opening/closing photocells

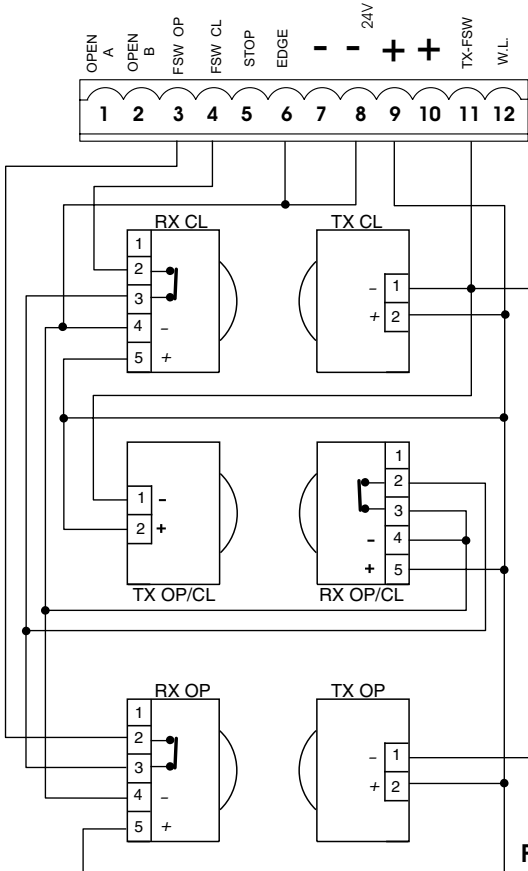

Fig. 12

Connection of two N.O. contacts in parallel (e.g. Open A, Open B)

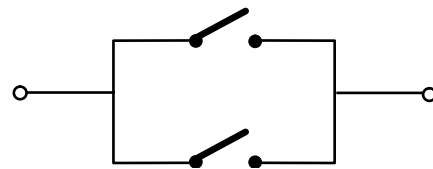

Fig. 14

**4.2. J7 Terminal board - Power supply (fig. 2)**

**POWER SUPPLY (terminals PE-N-L):**

- PE: Earth connection
- N : Power supply ( Neutral )
- L : Power supply ( Line )

**NB.:** For correct operation, the board must be connected to the earth conductor in the system. Install an adequate differential thermal breaker upstream of the system.

**4.3. J6 Terminal board - Motors and flashing lamp (fig. 2)**

**MOTOR - (terminals 13-14-15):** Motor connection.

In gearmotors with a built-in control unit, this connection is pre-wired standard. For leaf opening direction, see basic programming in Chpt 5.1.

**LAMP - (terminals 16 -17):** Flashing lamp output.

**4.4. J1 Terminal board - Accessories (fig. 2)**

**OPEN A - "Total Opening" command (terminal 1):** any pulse generator (push-button, detector, etc.) which, by closing a contact, commands total opening and/or closing of the gate leaf.

To install several total opening pulse generators, connect the N.O. contacts in parallel (see fig. 14).

**OPEN B - "Partial opening " or "Closing" command (terminal 2):** any pulse generator (push-button, detector, etc.) which, by closing a contact, commands partial opening and/or closing of the gate leaf. In the B and C logics, it always commands gate closure.

To install several partial opening pulse generators, connect the N.O. contacts in parallel (see fig. 14).



**FSW OP - Opening safety devices contact (terminal 3):** The purpose of the opening safety devices is to protect the leaf movement area during opening. During opening, in the **A-AP-S-E-EP** logics the safety devices reverse the movement of the gate leaves, or stop and restart the movement when they are released (see advanced programming in Chpt 5.2). During the opening cycle in logics **B** and **C**, they interrupt movement. They never operate during the closing cycle.

If the **Opening safety devices** are engaged when the gate is closed, they prevent the leaf opening movement.

To install several safety devices, connect the N.C. contacts in series (fig.4).

**NB.: If no opening safety devices are connected, jumper connect inputs OP and -TX FSW (fig. 5).**

**FSW CL - Closing safety devices contact (terminal 4):** The purpose of the closing safety devices is to protect the leaf movement area during closing. During closing, in the **A-AP-S-E-EP** logics, the safety devices reverse the movement of the gate leaves, or stop and reverse the movement when they are released (see advanced programming in Chpt 5.2). During the closing cycle in logics **B** and **C**, they interrupt movement. They never operate during the opening cycle. If the **Closing safety devices** are engaged when the gate is open, they prevent the leaf closing movement.

To install several safety devices, connect the N.C. contacts in series (fig.4).

**NB.: If no closing safety devices are connected, jumper connect terminals CL and -TX FSW (fig. 5).**

**STOP - STOP contact (terminal 5):** any device (e.g. a push-button) which, by opening a contact, is able to stop gate movement.

To install several STOP devices, connect the N.C. contacts in series.

**NB.: If STOP devices are not connected, jumper connect the STOP and - terminals.**

**EDGE - EDGE safety device contact (terminal 6):** The purpose of the "edge" safety device is to protect the leaf movement area during opening/closing against fixed obstacles (pillars, walls, etc.). In all logics, during opening and closing, the safety devices reverse gate leaf movement for 2 seconds. If the safety devices operate again during the 2-seconds reversing time, they STOP movement without any reversing. If the **Edge safety devices** are engaged while the gate is closed or open, they prevent the leaves movement.

To install several safety devices, connect the N.C. contacts in series (fig.4).

**NB.: If edge safety devices are not connected, jumper connect the EDGE and - inputs. (fig. 5).**

- **Negative for power supply to accessories (terminals 7 and 8)**

+ **24 Vdc - Positive for power supply to accessories (terminals 9 and 10)**

**Important:** Accessories max. load is 500 mA. To calculate absorption values, refer to the instructions for individual accessories.

**TX -FSW - Negative for power supply to photocell transmitters (terminal 11)**

If you use this terminal for connecting the negative for supplying power to the photocell transmitters, you may, if necessary, also use the FAILSAFE function (see advanced programming in Chpt 5.2).

If this function is enabled, the equipment checks operation of the photocells before every opening or closing cycle.

**W.L. - Power supply to indicator-light / timed output (terminal 12)**

Connect a 24 Vdc - 3 W max indicator-light or timed output, if necessary, between this terminal and the +24V supply (see advanced programming in Chpt 5.2).To avoid jeopardising correct operation of the system, **do not exceed** the indicated power.

**4.5. Connector J2 - Rapid connection to Minidec, Decoder and RP**

This is used for rapid connection of Minidec, Decoder and RP receivers (see fig. 15, 16 and 17). Connect the accessory, with the components side facing the inside of the board. Insert and remove after cutting power.

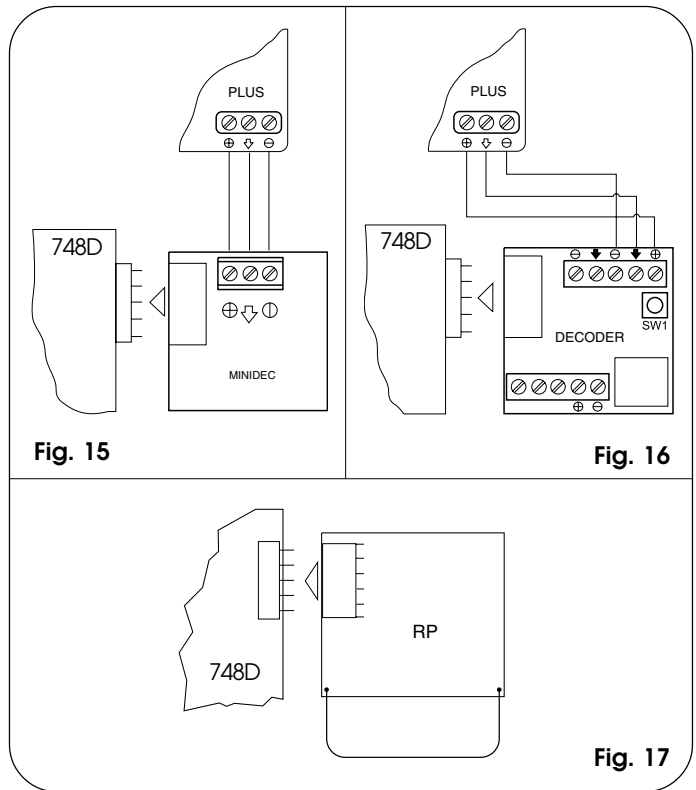

**4.6. Connector J6 - Limit-switches rapid connection (fig.2)**

This input is intended for rapid connection of the opening and closing limit-switches designed to stop the leaf, or for start of decelerations or for braking (see advanced programming in Chpt. 5.2.). In gearmotors with a built-in control unit, this connection is pre-wired as standard (fig. 2). For leaf opening direction, see advanced programming in Chpt 5.2.

**4.7. Connector J3 - Encoder rapid connection (fig.2)**

This input is designed for rapid connection of the Encoder (optional). To fit the encoder on the motor, refer to the relevant instructions.

The presence of the encoder is signalled - when the gearmotor is running - by the flashing of the "Encoder" LED on the board. When the encoder is used, the control unit knows the exact position of the gate while it is moving.

The encoder controls the adjustments of some of the control unit's functions in a different way (partial opening or deceleration - see advanced programming in Chpt 5.2) and as an anti-crushing device.

If the gate strikes an obstacle during opening or closing, the encoder immediately reverses the gate leaf for 2 seconds. If the encoder operates again during the 2-seconds reversing time, it STOPS movement without commanding any reversing.

**5. PROGRAMMING**

To program operation of the automated system, you have to access the "PROGRAMMING" mode.

Programming is split into two parts: *BASIC* and *ADVANCED*.

**5.1. BASIC PROGRAMMING**

To access BASIC PROGRAMMING, press key **F**:

- if you press it (and hold it down), the display shows the name of the first function.
- if you release the key, the display shows the value of the function that can be modified with keys **+** and **-**.
- if you press **F** again (and hold it down), the display shows the name of the next function, etc.
- when you reach the last function, press **F** to exit the program, and the display resumes showing the gate status.

The following table shows the sequence of functions accessible in BASIC PROGRAMMING:

BASIC PROGRAMMING (F)		
Display	Function	Default
LO	<b>FUNCTION LOGICS (see tab. 3/a - g):</b> A = Automatic AP = "Stepped" automatic S = "Safety" Automatic E = Semi-automatic EP = "Stepped" Semi-automatic C = Dead-man b = "B" Semi-automatic	A
PA	<b>PAUSE TIME:</b> This has effect only if the automatic logic was selected. Adjustable from 0 to 59 sec. in one-second steps. Subsequently, display changes to minutes and tens of seconds (separated by a point) and time is adjusted in 10-second steps, up to the maximum value of 4.1 minutes. E.g. if the display shows 2.5, pause time is 2 min. and 50 sec.	2.0
FO	<b>FORCE:</b> Adjusts Motor thrust. 01 = minimum force 50 = maximum force	25
d1	<b>OPENING DIRECTION:</b> Indicates the gate opening movement and makes it possible not to change the motor and limit-switch connections on the terminal board. -3 = Right-hand opening movement E- = Left-hand opening movement	-3
St	<b>GATE STATUS:</b> Exit from programming and return to gate status viewing. 00 = Closed 01 = Now opening 02 = Stopped 03 = Open 04 = Pause 05 = "FAIL SAFE" tripped (chpt. 5.2) 06 = Now closing 07 = Now reversing	

**5.2. ADVANCED PROGRAMMING**

To access ADVANCED PROGRAMMING, press key **F** and, as you hold it down, press key **+**:

- if you release key **+**, the display indicates the name of the first function.
- if you release key **F** too, the display shows the value of the function that can be modified with keys **+** and **-**.
- if you press key **F** (and hold it down), the display shows the name of the next function, and if you release it, the value that can be modified with keys **+** and **-** is shown.
- when you reach the last function, press **F** to exit the program, and the display resumes showing the gate status.

The following table shows the sequence of functions accessible in ADVANCED PROGRAMMING:

ADVANCED PROGRAMMING (F + +)		
Display	Function	Default
bo	<b>MAXIMUM TORQUE AT INITIAL THRUST:</b> The motor operate at maximum torque (ignoring the torque setting) at start of movement. Useful for heavy leaves. y = Active no = Disabled	y
br	<b>FINAL BRAKING:</b> When the gate engages the opening or closing limit-switch, a braking stroke can be selected to ensure the leaf is stopped immediately. If decelerations are selected, braking starts when they finish. At 00 value, braking is disabled. Time can be adjusted from 01 to 20 sec. in 0.1-second steps. E.g. if the display indicates 10, braking time is 1 second. 00 = Braking disabled from 01 to 20 = Timed braking	00
FS	<b>FAIL SAFE:</b> If this function is activated, it enables a function test of the photocells before any gate movement. If the test fails (photocells not serviceable signalled by value 05 on the display), the gate does not start moving. y = Active no = Disabled	no
PF	<b>PRE-FLASHING (5 s):</b> Activates the flashing lamp for 5 sec. before start of movement. y = Active no = Disabled	no
SP	<b>INDICATOR-LIGHT:</b> If 00 is selected, the output functions as a standard indicator-light (lighted at opening and pause, flashing at closing, and off when gate closed). Different figures correspond to timed activation of the output, which can be used (via a relay) to power a courtesy lamp. Time can be adjusted from 0 to 59 sec. in 1-second steps, and from 10 to 4.1 min. in 10-second steps. 00 = Standard indicator-light from 01 to 4.1 = Timed output	00

Display	Function	Default
PH	<p><b>CLOSING PHOTOCELLS LOGIC:</b> Select the tripping mode of the closing photocells. They operate for the closing movement only: they stop movement and reverse it when they are released, or they reverse it immediately. Y = Reverse on release no = Reverse immediately when opening</p>	no
oP	<p><b>OPENING PHOTOCELLS LOGIC:</b> Select the tripping mode of the opening photocells. They operate for the opening movement only: they stop the movement and restart it when they are released, or they reverse it immediately. Y = Reverse immediately when closing no = Restart movement on release</p>	no
EC	<p><b>ENCODER:</b> If the encoder (optional) is used, you may select its presence. If the encoder is present and enabled, "decelerations" and "partial opening" are controlled by the encoder (see relevant paragraphs). The encoder operates as an anti-crushing device: If the gate strikes an obstacle during opening or closing, the encoder immediately reverses gate leaf movement for 2 seconds. If the encoder operates again during the 2-seconds reversing time, it STOPS movement without commanding any reversing. Y = Encoder enabled no = Encoder disabled</p>	no
rA	<p><b>DECELERATIONS:</b> You can select gate deceleration after the opening and closing limit-switches have been tripped. Time can be adjusted from 00 to 09 sec. in 0.04-second steps. The maximum value of 09 corresponds to about 7 cm. If an encoder (optional) is used, the adjustment is not determined by time but by motor revs, thus obtaining greater deceleration precision. 00 = Deceleration disabled from 01 to 09 = Deceleration enabled</p>	05
P0	<p><b>PARTIAL OPENING:</b> You can adjust the width of leaf partial opening. Time can be adjusted from 01 to 20 sec. in 0.1-second steps. If an encoder (optional) is used, the adjustment is not determined by time but by motor revs, thus obtaining greater precision of partial opening. E.g. for a gate with a sliding speed of 10 m /min, value 10 corresponds to about 1.7 metres of opening. E.g. for a gate with a sliding speed of 12 m /min, value 10 corresponds to about 2 metres of opening.</p>	05

Display	Function	Default
t	<p><b>WORK TIME:</b> We advise you to set a value of 5 to 10 seconds over the time taken by the gate to travel from the closing limit-switch to the opening limit-switch and vice versa. This will protect the motor against any overheating if a limit-switch fails. Adjustable from 0 to 59 sec. sec. in one-second steps. Subsequently, viewing changes to minutes and tens of seconds (separated by a point) and time is adjusted in 10 second steps, up to a maximum value of 41 minutes. E.g. if the display shows 25, work time is 2 min. and 50 sec.</p>	41
AS	<p><b>ASSISTANCE REQUEST (combined with next function):</b> If activated, at the end of countdown (settable with the next function i.e. "Cycle programming") it effects 2sec. of pre-flashing at every Open pulse (job request). Can be useful for setting scheduled maintenance jobs. Y = Active no = Disabled</p>	no
nc	<p><b>CYCLE PROGRAMMING:</b> For setting countdown of system operation cycles. Settable (in thousands) from 00 to 99 thousand cycles. The displayed value is updated as cycles proceed. This function can be used to check use of the board or to exploit the "Assistance request".</p>	00
St	<p><b>GATE STATUS:</b> Exit from programming and return to gate status viewing (see Chpt 5.1.).</p>	

## 6. START-UP

### 6.1. INPUTS CHECK

The table below shows the status of the LEDs in relation to the status of the inputs.

Note the following: **LED LIGHTED** = closed contact  
**LED OFF** = open contact

Check the status of the LEDs as per Table.

#### Operation of the signalling status LEDs

LEDS	LIGHTED	OFF
FCA	Limit-switch free	Limit-switch engaged
FCC	Limit-switch free	Limit-switch engaged
OPEN B	Command activated	Command inactive
OPEN A	Command activated	Command inactive
FSW OP	Safety devices disengaged	Safety devices engaged
FSW CL	Safety devices disengaged	Safety devices engaged
STOP	Command inactive	Command activated
EDGE	Safety devices disengaged	Safety devices engaged

NB.: The status of the LEDs while the gate is closed at rest are shown in bold.

## 7. AUTOMATED SYSTEM TEST

When you have finished programming, check if the system is operating correctly.

Most important of all, check if the force is adequately adjusted and if the safety devices are operating correctly.

Table 3/a

PULSES							
LOGIC "A"	OPEN-A	OPEN-B	STOP	OPENING SAFETY DEVICES	CLOSING SAFETY DEVICES	OP/CLOS. SAFETY DEVICE	EDGE SAFETY DEVICE
<b>GATE STATUS</b>							
<b>CLOSED</b>	Opens the leaf and closes it after pause time (t)	Opens leaf for the partial opening time and closes after pause time (t)	No effect (OPEN disabled)	No effect (OPEN disabled)	No effect	No effect (OPEN disabled)	No effect (OPEN disabled)
<b>OPEN on PAUSE</b>	Re-closes the leaf immediately	Re-closes the leaf immediately	Stops operation	No effect	Reloads pause time (t) (OPEN disabled)	No effect (OPEN disabled)	No effect (OPEN disabled)
<b>ON CLOSING</b>	Re-operates the leaf immediately (t)	Re-operates the leaf immediately (t)	Stops operation	No effect (saves OPEN)	see paragraph 5.2.	Stops and, on release, reverses on opening	Reverses on opening for Z (2)
<b>ON OPENING</b>	No effect (t)	No effect (t)	No effect (OPEN disabled)	see paragraph 5.2.	No effect	Stops and, on release, continues opening	Reverses on closing for Z (2)
<b>STOPPED</b>	Closes the leaf	Closes the leaf	No effect (OPEN disabled)	No effect	No effect	No effect (OPEN disabled)	No effect (OPEN disabled)

Table 3/b

PULSES							
LOGIC "A"	OPEN-A	OPEN-B	STOP	OPENING SAFETY DEVICES	CLOSING SAFETY DEVICES	OP/CLOS. SAFETY DEVICE	EDGE SAFETY DEVICE
<b>GATE STATUS</b>							
<b>CLOSED</b>	Opens the leaf and closes it after pause time (t)	Opens leaf for the partial opening time and closes after pause time (t)	No effect (OPEN disabled)	No effect (OPEN disabled)	No effect	No effect (OPEN disabled)	No effect (OPEN disabled)
<b>OPEN on PAUSE</b>	Re-closes the leaf immediately	Re-closes the leaf immediately	Stops operation	No effect	Reloads pause time (t) (OPEN disabled)	No effect (OPEN disabled)	No effect (OPEN disabled)
<b>ON CLOSING</b>	Re-operates the leaf immediately (t)	Re-operates the leaf immediately (t)	Stops operation	No effect (saves OPEN)	see paragraph 5.2.	Stops and, on release, reverses on opening	Reverses on opening for Z (2)
<b>ON OPENING</b>	Stops operation	Stops operation	No effect (OPEN disabled)	see paragraph 5.2.	No effect	Stops and, on release, continues opening	Reverses on closing for Z (2)
<b>STOPPED</b>	Closes the leaf	Closes the leaf	No effect (OPEN disabled)	No effect	No effect	No effect (OPEN disabled)	No effect (OPEN disabled)

Table 3/c

PULSES							
LOGIC "S"	OPEN-A	OPEN-B	STOP	OPENING SAFETY DEVICES	CLOSING SAFETY DEVICES	OP/CLOS. SAFETY DEVICE	EDGE SAFETY DEVICE
<b>GATE STATUS</b>							
<b>CLOSED</b>	Opens leaves and closes them after pause time	Opens leaf for the partial opening time and closes after pause time (t)	No effect (OPEN disabled)	No effect (OPEN disabled)	No effect	No effect (OPEN disabled)	No effect (OPEN disabled)
<b>OPEN on PAUSE</b>	Re-closes the leaf immediately	Re-closes the leaf immediately	Stops operation	No effect	Closes after t* (OPEN disabled)	No effect (OPEN disabled)	No effect (OPEN disabled)
<b>ON CLOSING</b>	Re-operates the leaf immediately	Re-operates the leaf immediately	Stops operation	No effect (saves OPEN)	see paragraph 5.2.	Stops and, on release, reverses on opening	Reverses on opening for Z (2)
<b>ON OPENING</b>	Re-closes the leaf immediately	Re-closes the leaf immediately	No effect (OPEN disabled)	see paragraph 5.2.	No effect	Stops and, on release, continues opening	Reverses on closing for Z (2)
<b>STOPPED</b>	Closes the leaf	Closes the leaf	No effect (OPEN disabled)	No effect	No effect	No effect (OPEN disabled)	No effect (OPEN disabled)

Table 3/d

PULSES							
LOGIC "E"	OPEN-A	OPEN-B	STOP	OPENING SAFETY DEVICES	CLOSING SAFETY DEVICES	OP/CLOS. SAFETY DEVICE	EDGE SAFETY DEVICE
<b>GATE STATUS</b>							
<b>CLOSED</b>	Opens the leaf	Opens the leaf for partial opening time	No effect (OPEN disabled)	No effect (OPEN disabled)	No effect	No effect (OPEN disabled)	No effect (OPEN disabled)
<b>OPEN</b>	Re-closes the leaf immediately	Re-closes the leaf immediately	Stops operation	No effect	No effect (OPEN disabled)	No effect (OPEN disabled)	No effect (OPEN disabled)
<b>ON CLOSING</b>	Re-operates the leaf immediately	Re-operates the leaf immediately	Stops operation	No effect (saves OPEN)	see paragraph 5.2.	Stops and, on release, reverses on opening	Reverses on opening for Z (2)
<b>ON OPENING</b>	Stops operation	Stops operation	No effect (OPEN disabled)	see paragraph 5.2.	No effect	Stops and, on release, continues opening	Reverses on closing for Z (2)
<b>STOPPED</b>	Closes the leaf (with the Closing safety devices engaged, it opens after the 2nd pulse)	Closes the leaf	No effect (OPEN disabled)	No effect	No effect	No effect (OPEN disabled)	No effect (OPEN disabled)

Table 3/e

PULSES							
LOGIC "EP"	OPEN-A	OPEN-B	STOP	OPENING SAFETY DEVICES	CLOSING SAFETY DEVICES	OP/CLOS. SAFETY DEVICE	EDGE SAFETY DEVICE
<b>CLOSED</b>	Opens the leaf	Opens the leaf for partial opening time	No effect (OPEN-A disabled)	No effect (OPEN-A disabled)	No effect	No effect (OPEN-A disabled)	No effect (OPEN-A disabled)
<b>OPEN</b>	Re-closes the leaf immediately		Stops operation	No effect		No effect (OPEN-A disabled)	
<b>ON CLOSING</b>	Stops operation			No effect (saves OPEN)	see paragraph 5.2.	Stops and, on release, reverses on opening	Reverses on opening for Z (2)
<b>ON OPENING</b>	Stops operation			see paragraph 5.2.	No effect	Stops and, on release, continues opening	Reverses on closing for Z (2)
<b>STOPPED</b>	Restarts movement in reverse direction (always closes after a stop)		No effect (OPEN-A disabled)	No effect (if firmust open, it disables OPEN)	No effect (if firmust close, it disables OPEN)	No effect (OPEN-A disabled)	No effect (OPEN-A disabled)

Table 3/f

PULSES							
LOGIC "C"	CONTROLS ALWAYS HELD DOWN		STOP	OPENING SAFETY DEVICES	CLOSING SAFETY DEVICES	OP/CLOS. SAFETY DEVICE	EDGE SAFETY DEVICE
	OPEN-A (opening)	OPEN-B (closing)					
<b>CLOSED</b>	Opens the leaf	No effect	No effect (OPEN-A disabled)	No effect (OPEN-A disabled)	No effect (OPEN-B disabled)	No effect (OPEN-A disabled)	No effect (OPEN-A/B disabled)
<b>OPEN</b>	No effect	Closes the leaf	No effect (OPEN-B disabled)	No effect (OPEN-A disabled)	No effect (OPEN-B disabled)	No effect (OPEN-B disabled)	No effect (OPEN-A/B disabled)
<b>ON CLOSING</b>	Stops operation		Stops operation	Stops operation (OPEN-A disabled)	Stops operation (OPEN-B disabled)	Stops operation (OPEN-A/B disabled)	Reverses on opening for Z (2)
<b>ON OPENING</b>		Stops operation	Stops operation (OPEN-A disabled)	No effect	No effect	Stops operation (OPEN-A/B disabled)	Reverses on closing for Z (2)

Table 3/g

PULSES							
LOGIC "B"	OPEN-A (opening)	OPEN-B (closing)	STOP	OPENING SAFETY DEVICES	CLOSING SAFETY DEVICES	OP/CLOS. SAFETY DEVICE	EDGE SAFETY DEVICE
<b>OPEN</b>	No effect	Closes the leaf	No effect (OPEN-B disabled)	No effect (OPEN-A disabled)	No effect (OPEN-B disabled)	No effect (OPEN-B disabled)	No effect (OPEN-A/B disabled)
<b>ON CLOSING</b>	Reverses on opening	No effect	Stops operation	No effect	Stops operation (OPEN-B disabled)	Stops operation (OPEN-A/B disabled)	Reverses on opening for Z (2)
<b>ON OPENING</b>	No effect	No effect		Stops operation (OPEN-A disabled)	No effect	Stops operation (OPEN-A/B disabled)	Reverses on closing for Z (2)
<b>STOPPED</b>	Opens the leaf	Closes the leaf	No effect (OPEN-A/B disabled)	No effect (OPEN-A disabled)	No effect (OPEN-A disabled)	No effect (OPEN-A/B disabled)	No effect (OPEN-A/B disabled)

(1) If maintained, it prolongs the pause until disabled by the command (timer function)

(2) If a new pulse occurs within 2 seconds after reversing, it immediately stops operation.

NB.: Effects on other active pulse inputs in brackets.