

## PSAM-1 Alarm Module

### General Description

The PSAM-1 Alarm Module is dedicated for operation with PS20 v3.0 and PS15V24 v3.0 buffered power supplies. The main purpose of module is to provide supervision of emergency condition which may occur on power supply. PSAM-1 may detect and signalize: low level of battery, battery failure and lack of AC supply. The PSAM-1 can be configured for autonomic or networked operation. When configured for autonomic mode each alarm detected by module is signalized on separate transistor output and on BUZZER. When module operate in networked mode it must be connected to some type of PRxx2 series access controller, in this case when any alarm is detected module send adequate messages to host device through Clock and Data lines. In network mode the transistor outputs are used for communication purposes and can not be utilized for alarm signalization. The PSAM-1 is delivered as printed board circuit module together with additional mounting items.

### Autonomic Mode

In this mode the PSAM-1 signalize alarms on transistor outputs. The module offer three outputs marked as ACL, LB and BF. All outputs have the same electrical structure and are capable to sink up to 20mA current which is suitable to drive LED or 12VDC relay (coil resistance 600Ω or higher). Normally each transistor output remains in high impedance state, when triggered it shorts connected signal to supply minus. All outputs are electronically protected against current overload and voltages impulses which may occur during switching of inductive loads (e.g. coils). If at least one alarm is detected the PSAM-1 generate short acoustic BEEP every one minutes, the acoustic signalization ceases when all alarms disappear.

### Networked Mode

In this mode the alarm module must be connected to some type of PRxx2 series access controllers, the ACL and LB lines are used in this case for communication with host device (access controller). In networked mode the PSAM-1 sends messages about alarms and actual voltage level which exist on power's supply DC output to access controller, alarms can be further presented on PC monitor screen as well as registered in events memory. When communication between alarm module and host device is corrupted the PSAM-1 internal buzzer starts to generate periodically short beep, the lack of communication with module is registered by access controller.

## Connection Terminals

### ACL Output (AC Lost)

In autonomic mode this output goes low when module detect a lack of AC supply which duration is longer then ~4 minutes. The output returns to normal condition immediately after AC supply return. In networked mode the ACL lines serve as DATA communication wire.

### LB Output (Low Battery)

In autonomic mode this output goes low when module detect that the voltage on reserve battery falls below ~11.5V level, the alarm disappear when battery level returns above this level. In networked mode the LB lines serve as CLOCK communication wire.

### BF Output (Battery Failure)

In autonomic mode this output goes low when module detect that during charging the voltage on reserve battery falls below ~11.0V level, the alarm disappear when battery level returns above this level. In networked mode the BF lines is not used.

*Note: When Battery Failure and Low Battery alarm are active it may be caused be following reasons:*

- *battery protection fuse failure*
- *battery not connected*
- *the internal resistance of battery is high (battery damaged)*

### Installation

Disconnect AC and battery from power supply. Using mounting elements delivered together with PSAM-1 install alarm module above power's supply printed circuit board (see mounting diagram), connect alarm module to CON4 slot located on PS' board. Select adequate address on PSAM-1 configuration jumpers (for address settings refer to access controller manual) or leave jumpers open when device is dedicated for autonomic mode. Connect ACL and LB output lines to access controller or to another device which will provide alarm signalization (LED, Sire, Alarm Control Panel etc). When PSAM-1 and host device (access controller, control panel) are supplied from different power sources, connect both supply minuses together.

| Jumper Settings Table |           |           |                    |
|-----------------------|-----------|-----------|--------------------|
| ADDRESS 1             | ADDRESS 0 | RACS Mode | Mode               |
| open                  | open      | closed    | RACS: Address ID=7 |
| open                  | closed    | closed    | RACS: Address ID=6 |
| closed                | open      | closed    | RACS: Address ID=5 |
| closed                | closed    | closed    | RACS: Address ID=4 |
| open                  | open      | open      | Autonomic          |

Note: Do not adjust potentiometers located on PS' power supply printed circuit board, those elements are factory preset. Any unauthorized adjust may lead to improper behavior of PSAM-1 module as well as malfunction in power supply operation.

| Technical Specification                              |   |
|--|---|
| Supply   | 10-16Vdc (retrieved from power supply through CON4 connector) |
| Current consumption                                  | ~15mA (delivered from power supply through CON4 connector)    |
| Outputs  | Three transistor outputs, 20mA max sink current, 16Vdc.       |
| Voltage level measurement precision                  | ±0,2V   |
| Communication protocol (Networked mode)              | <i>Clock &amp; Data</i> (RACS protocol)                       |
| Max. communication distance to host (Networked mode) | 150 m (500 ft)  |
| Operating temperature                                | 0-55°C  |
| Relative humidity                                    | 10-95%  |
| Dimensions   | 33 X 66   |

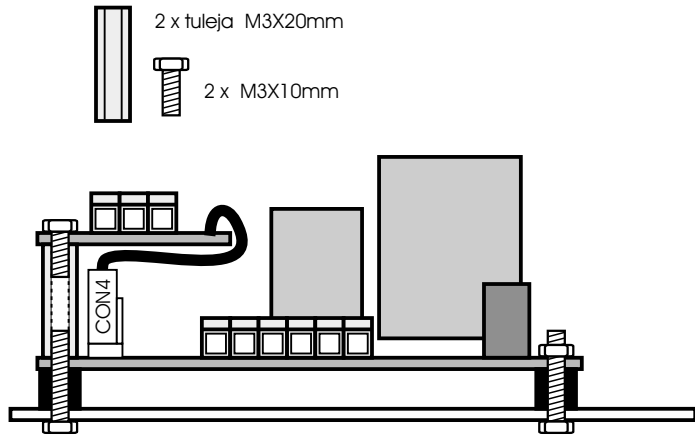

PSAM-1 Mounting diagram

| Configuration Jumpers               |      |                        |
|-------------------------------------|------|------------------------|
| JUMPER                              | Mode |                        |
| RACS Mode<br>ADDRESS 0<br>ADDRESS 1 |      | Autonomic              |
| RACS Mode<br>ADDRESS 0<br>ADDRESS 1 |      | RACS Mode<br>Address=7 |
| RACS Mode<br>ADDRESS 0<br>ADDRESS 1 |      | RACS Mode<br>Address=6 |
| RACS Mode<br>ADDRESS 0<br>ADDRESS 1 |      | RACS Mode<br>Address=5 |
| RACS Mode<br>ADDRESS 0<br>ADDRESS 1 |      | RACS Mode<br>Address=4 |

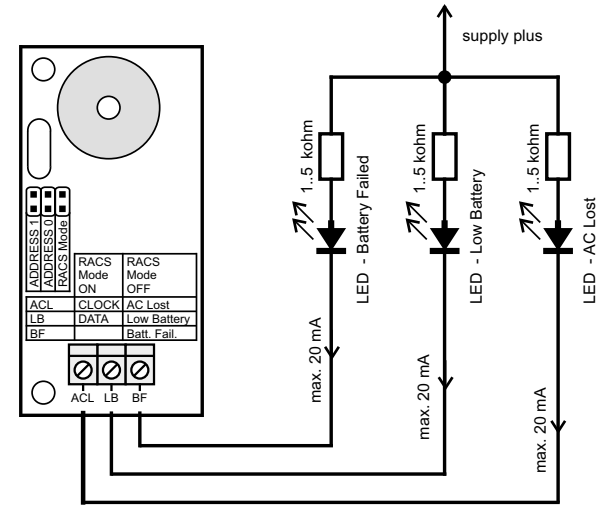

PSAM-1 autonomic mode - wiring diagram

**Warning !**  
Do not adjust potentiometers located on electronic board

PSAM-1 optional alarm module

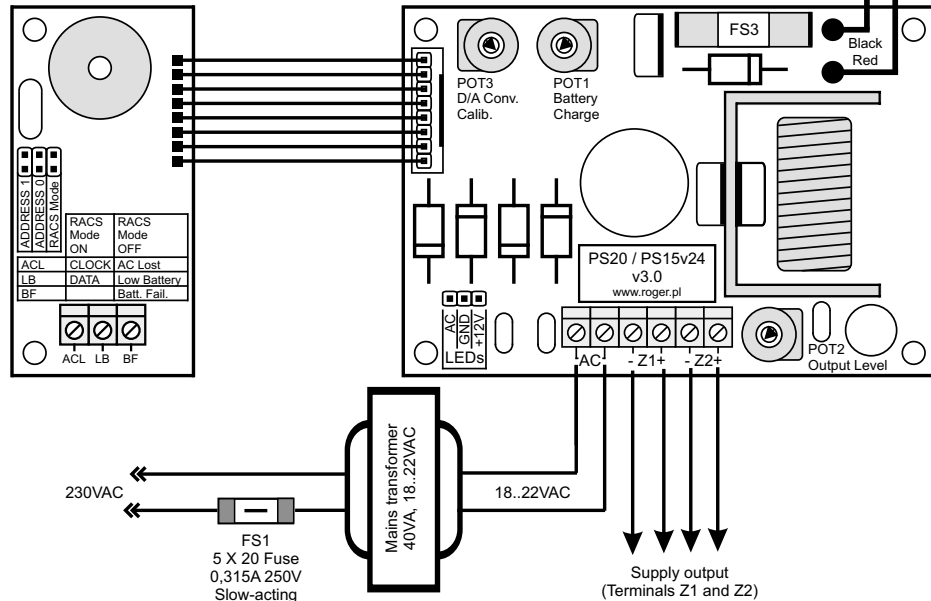

PS20/PSAM-1 Installation diagrams

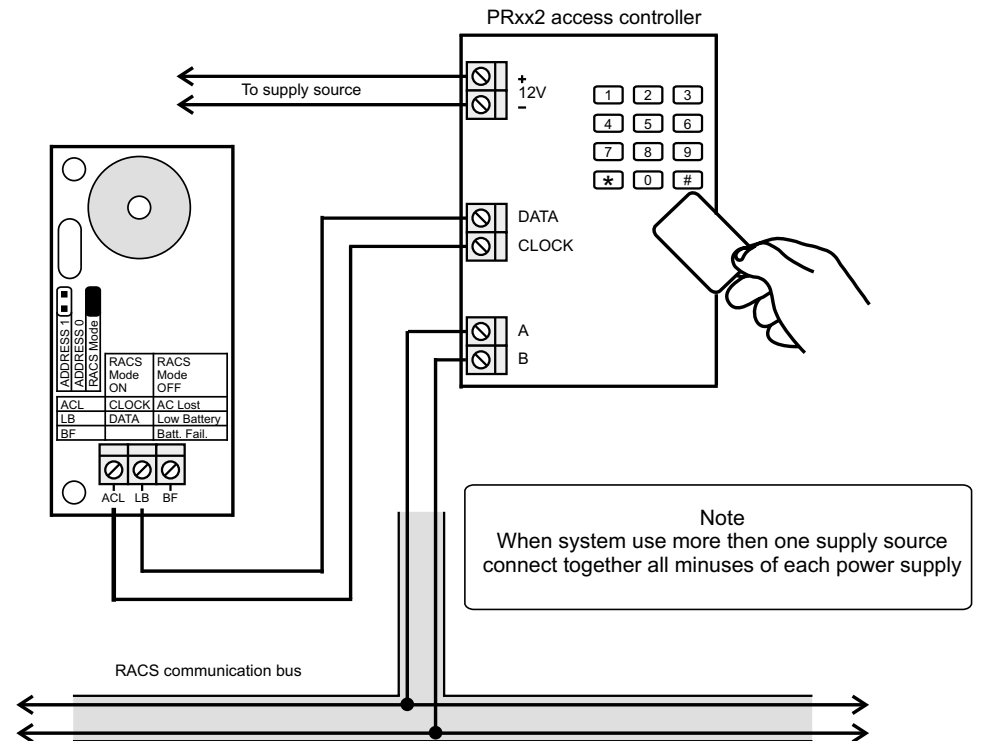

PSAM-1 networked mode - wiring diagram