

XM-8 Input/Output Expander

General Description

The XM-8 Input/Output expander is dedicated for operation with PRxx2 access controllers. Expander provides eight NO/NC inputs and eight relay outputs, each relay output offer NO/NC dry contact. The XM-8 is a addressable microprocessor device which is controlled from host through Clock and Data communication lines (RACS protocol). The main purpose of XM-8 I/O module is to extend number of inputs and outputs available for PRxx2 controller. The setup of XM-8's inputs and outputs is achieved during configuration of host device which the module is connected to, actually the firmware of PRxx2 (v125.0) enable the XM-8 to be configured as a lift access module or alternatively as an multi-door access selector. The XM-8 is delivered as PCB module without case and requires 12Vdc supply.

Features

- 12V dc supply
- Communication via Clock & Data lines (RACS)
- Eight NO/NC inputs
- Eight relay type outputs
- Relay activation signalized on LED
- Operating temperature -30°C...60°C.
- CE Mark.

Installation

Locate module in a installation box, all electrical connections and address settings should be made with power supply off. Once wiring is complete, power up the device. If host device and XM-8 are supplied from different power sources, short supply minuses of both devices. When module is installed in adequate housing which deliver sufficient protection against moisture it may be located in external locations (XM-8 offers -30/+60 °C operation). The configuration of XM-8 inputs and outputs is performed during host device setup. It is strongly suggested to install module in distant location (min. 1.5m) from inductive loads and other sources of strong electromagnetic interferences.

Connection Terminals Descriptions

DC SUPPLY INPUTS, TERMINALS: +/- 12V

The XM-8 should be supplied from 11.0 to 16.0V DC current source equipped with reserve battery. The average current consumption of module is about ~30 mA and may increase up to ~400 mA when all relays outputs will be activated. Care must be taken when selecting cable diameter for supply lines, installer must calculate the maximum voltage dropout on supply wires which should not excess 1V in worst case, this is very important especially when door lock is supplied from the same supply source as XM-8 module and other electronic equipment. Generally it is preferable to use separate supply sources for electronic equipment and door locks. When both elements (door lock and electronic equipment) are supplied from the same power source it is strongly recommended to supply them through separate pairs of wires.

INPUTS, TERMINALS: IN1, IN2...IN8

All the inputs have the same electrical structure, they can be configured as NO or NC. Each input is internally connected to supply plus through 5,6 kΩ resistor. The NO type input is triggered when connecting it to supply minus, the NC input must be normally shorted with supply minus, when disconnected from supply minus it became triggered.

OUTPUTS, TERMINALS: NO1, NC1, COM1 ... NO8, NC8, COM8

All those outputs are relay type and offers normally open and normally closed contacts rating for 1.5A/24V dc/ac. Both pair of relay contact (NO-COM and NC-COM) available on each relay are protected with over-voltage elements (MOV) which reduce sparks during switching of inductive loads (e.g. such a electric locks) and thus extend relay contacts life significantly.

Note: Using relay contact to switch voltages above 30V may damage relay protection elements (MOV) and lead to relay output's failure.

CLOCK & DATA INTERFACE, TERMINALS: CLK AND DTA

Both lines are used for communication between XM-8 and host device. The XM-8 and each other device connected to those lines should have individual address. The assignment of address depend on host device which module is connected to and to the function which module will be used in installation (for module address setting refer to host device installation manual). The address setting can be done on JP1-JP4 programming jumpers. There are no restrictions for types of cables used for CLK/DTA lines except that the maximum cable length may not exceed 150 meters (500Ft.).

Ordering

XM-8	The XM-8 module (PCB only)
------	----------------------------

Technical Specification

Supply	11-16V DC
Current consumption	~30 when no relay is triggered and up to ~400mA with all relays activated (approx. 50mA per relay)
Inputs	Eight NO/NC inputs, internal pull-up resistor 5.6K
Outputs	Eight relay outputs, NO/NC dry contact 1.5A/24V DC/AC rated
Communication distance	150m (between host device and XM-2 module)
Operating temperature	-30°C +60°C
Humidity	10-95% (without condensation)
Dimensions	152 X 78 mm
Wright	~175g

XM-8 Input/Output Expander Connection To Host Device And Address Setting Diagram

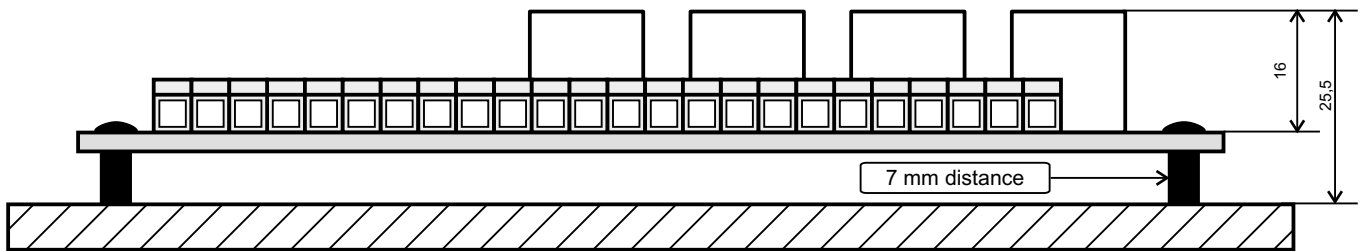
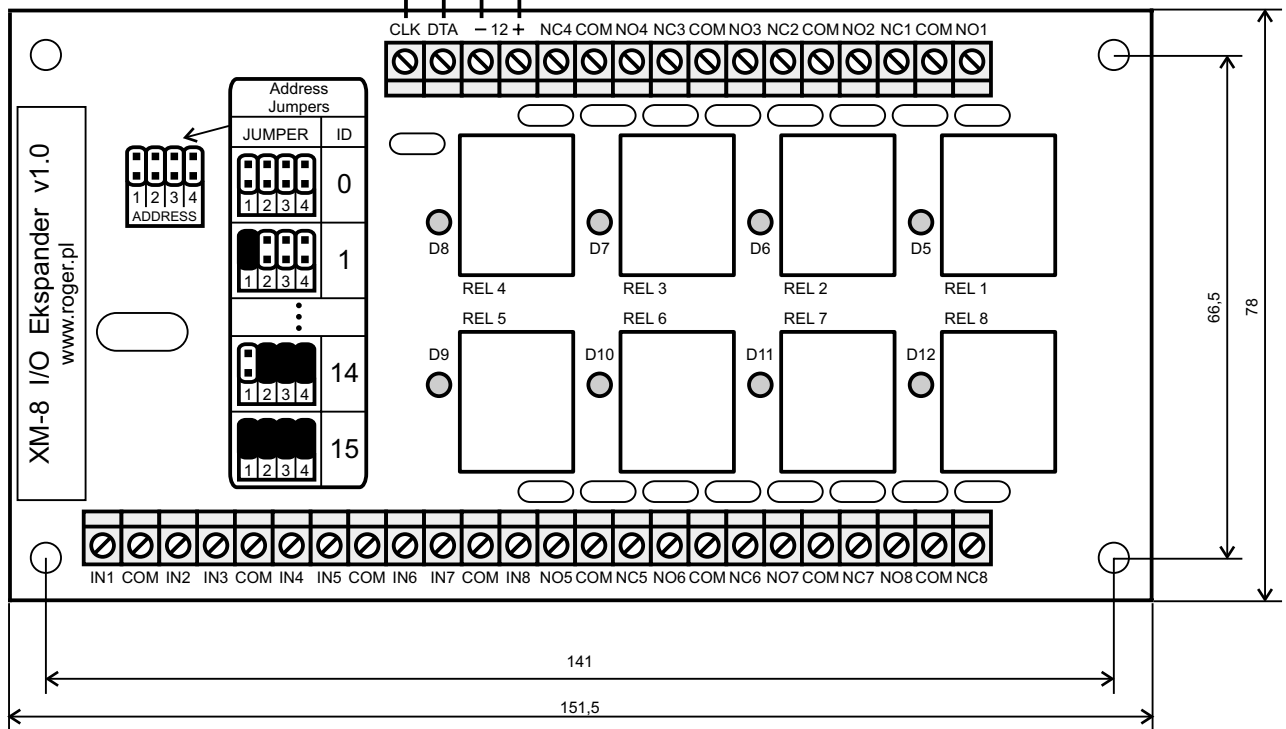
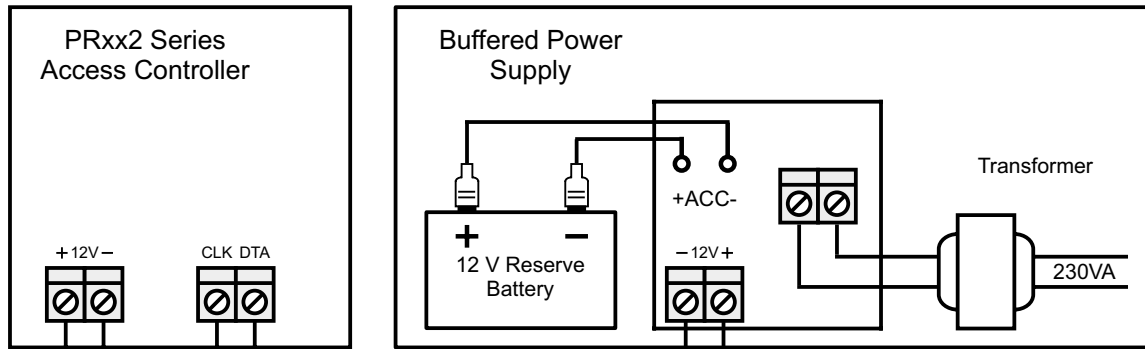

**Input Line Structure
IN1 ... IN8**

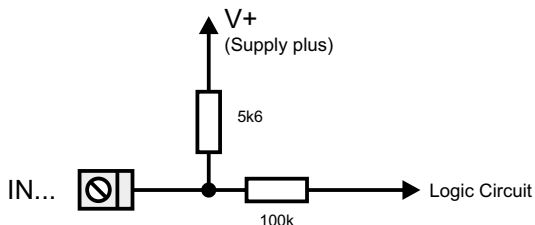

**Output Line Structure
REL1 ... REL8**

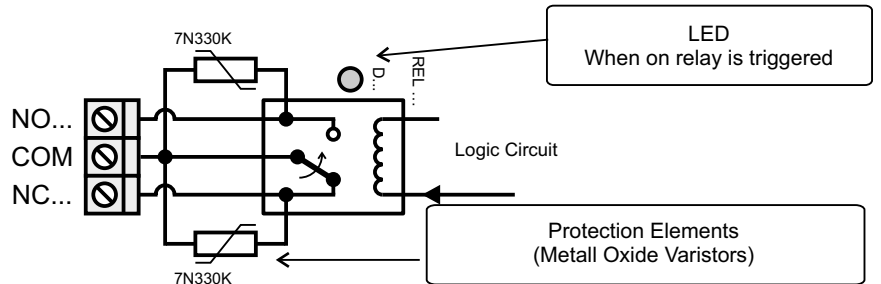

Using XM-8 As A Lift Access Control Module

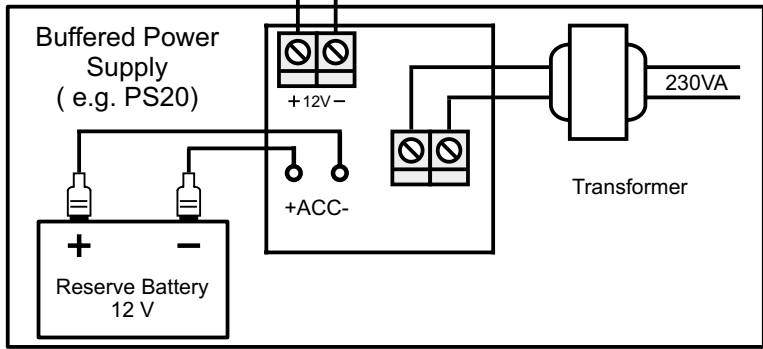
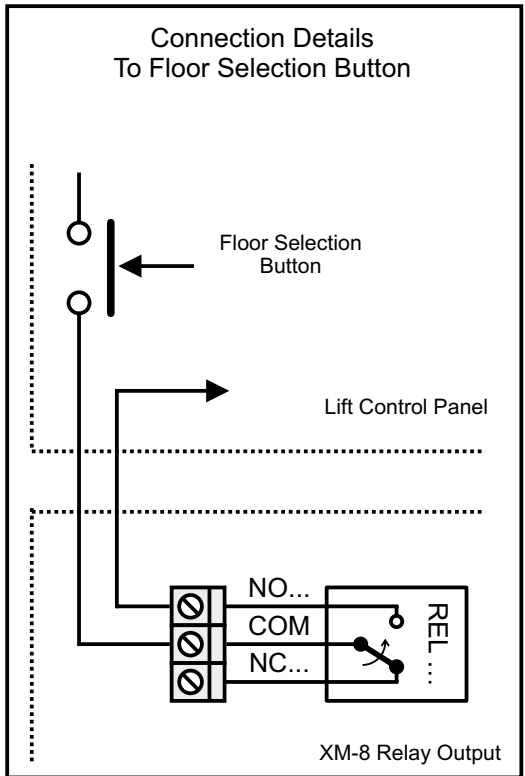
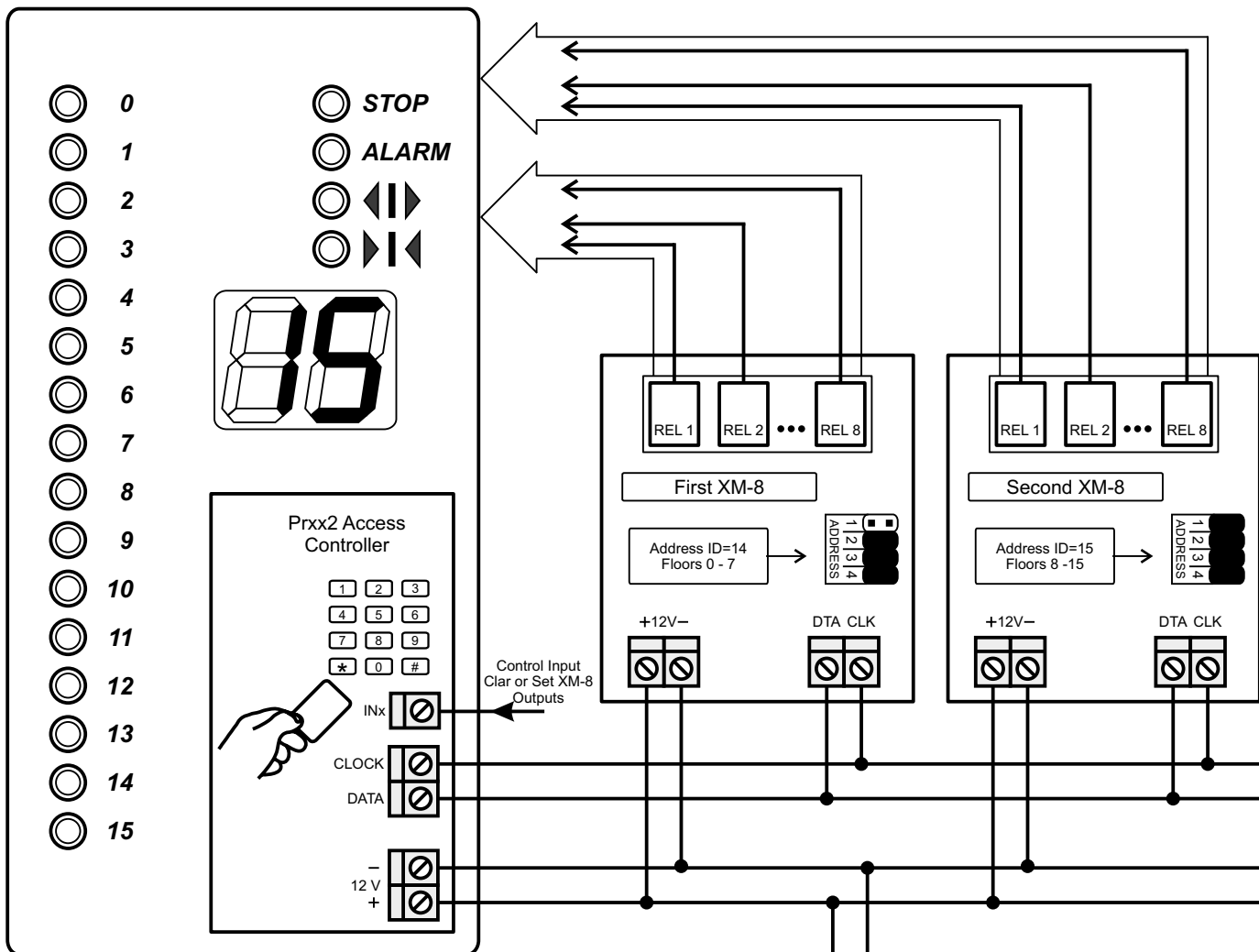

With this example access controller enables/disables user to select predefined set of floor buttons on lift control panel. Initially all buttons are disabled (all XM-8 outputs are cleared), after successful identification controller determine to which floors particular user may have access and after this activate adequate set of floor buttons through XM-8. The outputs remains active until controller recognize active level on its input line which is configured to option "Clears all outputs on XM-8" or till next user performs identification and controller will activate another set of XM-8 outputs.