



**MEDC Ltd**  
Colliery Road,  
Pinxton,  
Nottingham,  
NG16 6JF  
United Kingdom

Tel: +44 (0) 1773 864100  
Fax: +44 (0) 1773 582800  
E-mail: [sales@medc.com](mailto:sales@medc.com)  
Web-site: [www.medc.com](http://www.medc.com)

**MEDC International  
Houston USA**  
**MEDC Norway  
Stavange Norway**

Phone: +1 (713) 937 9772 Fax: +1 (713) 937 9773 E-Mail: [us.sales@medcint.com](mailto:us.sales@medcint.com)

Phone: +47 51 82 98 98 Fax: +47 51 82 98 91 E-Mail: [norway.sales@medc.com](mailto:norway.sales@medc.com)

## DB10 Range

### Wiring Details

#### Transformer Tappings Options:

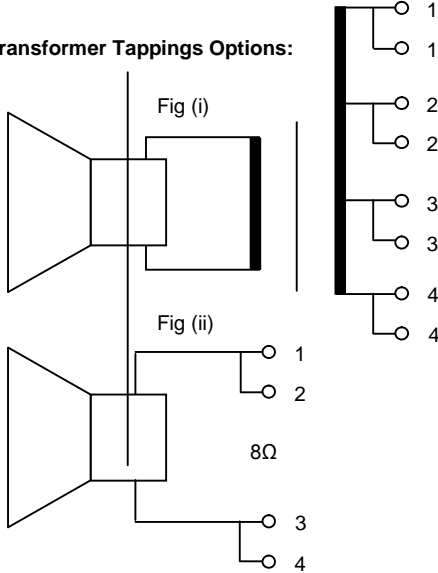

#### Transformer Options:

- Standard Tapping: Fig. 1) 8 terminals (4 x 2), loop in/loop out for 6 tappings.
- Standard Tapping: Fig. 2) 4 terminals (2 x 2), loop in/loop out, direct 8Ω connection to driver.

Transformer Tappings	Power	
	15W	8W
1:2	15.0	8.0
2:3	7.5	4.0
3:4	5.0	2.0
1:3	4.0	1.5
2:4	2.0	0.7
1:4	0.8	0.4

### Installation & Maintenance guidelines:

- Refer to technical manual enclosed with unit for further detailed instructions.
- When installing and operating explosion-proof electrical equipment, the relevant national Regulations for installation and operation (e.g. IEE Wiring Regulations) must be observed.
- Ensure that all nuts, bolts and fixings are secure.
- The DB10 is mounted via 2 off Ø7mm (Ø0.28") fixing holes in the 'U' shaped stirrup/mounting bracket. If required, the unit can be initially placed via the Ø13mm (Ø0.51") central hole in the stirrup. The unit can be rotated to the required position and fixed via the two other holes.
- The fixing holes have been designed to accept an M6 screw or bolt. MEDC recommend the use of stainless steel screws.
- The elevation of the unit can be adjusted by loosening the 2 off M6 screws which fasten the stirrup to the horn. The unit can then be adjusted by rotating to the required position and then tightening the M6 screws.
- The DB10 should be positioned such that debris, dust or water cannot settle in the re-entrant horn.
- During the working life of the unit, it should require little or no maintenance. GRP will resist attack by most acids, alkalis and chemicals and is as resistant to concentrated acids and alkalis as most metal products.
- If abnormal or unusual environmental conditions occur due to plant damage or accident etc., then visual inspection is recommended.
- If entry is required into the chamber containing the compression driver, then care should be taken not to damage the flamepath. Once reassembled, the gap between the flare and body must not exceed 0.15mm. During this operation, ensure power to the unit is isolated.
- If the unit requires cleaning, then only clean exterior with a damp cloth to avoid electro-static charge build up.
- If spare parts are required, then these should only be supplied by MEDC.