

# BioEntry™ Installation Guide

---

BioEntry™ Smart / Pass

Ver. 1.1

Suprema Inc and BioEntry™ are registered trademarks of Suprema Inc. All rights reserved. No part of this work covered by the copyright hereon may be reproduced or copied in any form or by any means - graphics, electronic, or mechanical, including photocopying, recording, taping, or information and retrieval systems - without written permission of Suprema Inc. Any software furnished under a license may be used or copied only in accordance with the terms of such license.

Suprema Inc reserves the right to modify or revise all or part of this document without notice and shall not be responsible for any loss, cost or damage, including consequential damage, caused by reliance on these materials.



## Suprema Warranty Policy

Suprema warrants to buyer, subject to the limitations set forth below, that each product shall operate in substantial accordance with the published specifications for such product for a period of one (1) year from the date of shipment of the products ("Warranty Period"). If buyer notifies Suprema in writing within the Warranty Period of any defects covered by this warranty, Suprema shall, at its option, repair or replace the defective product which is returned to Suprema within Warranty Period, freight and insurance prepaid by buyer. Such repair or replacement shall be Suprema's exclusive remedy for breach of warranty with respect to the Product. This limited warranty shall not extend to any product which has been: (i) subject to unusual physical or electrical stress, misuse, neglect, accident or abuse, or damaged by any other external causes; (ii) improperly repaired, altered or modified in any way unless such modification is approved in writing by the Supplier; (iii) improperly installed or used in violation of instructions furnished by Suprema.

Suprema shall be notified in writing of defects in the RMA report supplied by Suprema not later than thirty days after such defects have appeared and at the latest one year after the date of shipment of the Products. The report should give full details of each defected product, model number, invoice number and serial number. No product without RMA (Return Material Authorization) number issued by Suprema may be accepted and all defects must be reproducible for warranty service.

Except as expressly provided in the first paragraph, the products are delivered to Suprema without warranty of any kind, express or implied, including warranties or merchantability, fitness for a particular purpose.

## Disclaimers

Information in this document is provided in connection with Suprema products. No license, express or implied, by estoppels or otherwise, to any intellectual property rights is granted by this document. Except as provided in Suprema's Terms and Conditions of Sale for such products,

Suprema assumes no liability whatsoever, and Suprema disclaims any express or implied warranty, relating to sale and/or use of Suprema products including liability or warranties relating to fitness for a particular purpose, merchantability, or infringement of any patent, copyright or other intellectual property right.

Suprema products are not intended for use in medical, life saving, life sustaining applications, or other applications in which the failure of the Suprema product could create a situation where personal injury or death may occur. Should Buyer purchase or use Suprema products for any such unintended or unauthorized application, Buyer shall indemnify and hold Suprema and its officers, employees, subsidiaries, affiliates, and distributors harmless against all claims, costs, damages, and expenses, and reasonable attorney fees arising out of, directly or indirectly, any claim of personal injury or death associated with such unintended or unauthorized use, even if such claim alleges that Suprema was negligent regarding the design or manufacture of the part.

Suprema reserves the right to make changes to specifications and product descriptions at any time without notice to improve reliability, function, or design. Designers must not rely on the absence or characteristics of any features or instructions marked "reserved" or "undefined." Suprema reserves these for future definition and shall have no responsibility whatsoever for conflicts or incompatibilities arising from future changes to them.

Please contact Suprema, local Suprema sales representatives or local distributors to obtain the latest specifications and before placing your product order.

Note: Third-party brands and names are the property of their respective owners.

## About the BioEntry™ Series

BioEntry™ is an advanced biometric access reader equipped with award winning fingerprint recognition engine and standard Wiegand interface. BioEntry™ can practically replace legacy and simple readers and be instantly added onto existing access control systems as well as new installations.

BioEntry™ Smart is a fingerprint smart card reader that seamlessly integrates fingerprint and smart card reader into one device. BioEntry™ Smart is designed to replace existing access readers like proximity or magnetic readers without additional wiring. Fingerprint template is stored in each user's smart card and there is no need to store fingerprint data in a reader itself. This eliminates the burden of template management and networking readers.

BioEntry™ Pass is a fingerprint access reader equipped with fast one to many fingerprint identification engine. Enrolled with more than hundreds of users, identification can be done in less than one second.

Following the unique feature of Suprema's famous UniFinger™ fingerprint identification modules, BioEntry™ also provides customers with multiple choices of fingerprint sensors including optical, capacitive and thermal sensors.

## About Suprema Inc

Suprema is a leading biometric company offering core fingerprint technologies for embedded and PC applications. Suprema's fingerprint products include low cost standalone OEM modules, access control readers, USB fingerprint scanners and fingerprint algorithm SDK. Suprema's fingerprint recognition algorithm was proved to be world top level by ranking first in the 3<sup>rd</sup> international Fingerprint Verification Competition (FVC2004) with the lowest error rate in light category. Suprema's fingerprint products have been sold to more than 50 different countries and are being used in various applications. For more information on Suprema's technologies and products, please visit Suprema's website (<http://www.supremainc.com>) or contact by e-mail ([sales@supremainc.com](mailto:sales@supremainc.com)).

## About This Guide

This is an introduction to the installation of BioEntry™ Smart and Pass. This guide describes how to install, examples for BioEntry™ and technical specifications. The purpose of this guide is to provide instructions on using BioEntry™ Smart and Pass and troubleshooting minor problems.

## Contents

1.	Before you start with BioEntry™	10
1.1.	Included items	10
1.2.	Required items	10
1.3.	Optional items	10
2.	Installing BioEntry™	11
2.1.	Connecting wires	11
2.2.	Power connection	12
2.3.	Connecting to a Wiegand compatible reader	12
2.4.	Connecting to a Wiegand compatible access controller	12
2.5.	Connecting to the host PC	13
2.5.1.	Connecting via RS-232C interface	13
2.5.2.	Connecting via RS-485 interface for a full duplex BioEntry network system	13
2.5.3.	Connecting via RS-485 interface for a half duplex BioEntry network system	15
2.5.4.	Connecting via auxiliary interface	16
2.6.	Disassembling	17
2.7.	Mounting back plate	18
2.8.	Reassembling the BioEntry	18
2.9.	Installing the BioEntry™ Admin software	19
3.	Examples for BioEntry™ installation	20
3.1.	Building a new system	20
3.1.1.	Installing BioEntry Pass	20
3.1.2.	Installing BioEntry Smart	20
3.2.	Adding BioEntry to existing access control system	21
4.	Specifications	23
4.1.	Fingerprint authentication specifications	23
4.1.1.	Fingerprint authentication performance	23
4.1.2.	Fingerprint sensor specifications	23
4.1.3.	Data storage	23

---

4.2. Mechanical specifications.....	23
4.2.1. Operating range .....	23
4.2.2. Absolute maximum ratings.....	23
4.2.3. Electrical DC characteristics.....	24
4.3. Smart card specifications.....	24
4.4. Material information.....	24
4.5. RTC battery specification.....	24
5. Certification information .....	26
5.1. CE .....	26
5.2. FCC.....	26

## Figures

Figure 1> A full duplex BioEntry network .....	14
Figure 2> A half duplex BioEntry network .....	15
Figure 3> Connecting stereo plug to DB-9 cable .....	16
Figure 4> Auxiliary port.....	16
Figure 5> Aux. enable switch .....	17
Figure 6> Removing the screw .....	17
Figure 7> Separating the case.....	18
Figure 8> Installing back plate to the wall .....	18
Figure 9> Reassembling the case .....	19
Figure 10> BioEntry connection diagram .....	20
Figure 11> Adding BioEntry Pass to existing system.....	22



## Revision History

<b>Version</b>	<b>Date</b>	<b>Description</b>
V1.0	2005.9.27	Created.
V1.1	2005.12.2	ABA Track II wiring is added to Chapter 2.1 Connection wires.

## 1. Before you start with BioEntry™

### 1.1. Included items

- BioEntry Smart/Pass unit
- Stereo plug to DB-9 cable
- Star wrench
- 2 ferrite cores
- Quick Start Guide
- Mounting Template

### 1.2. Required items

- A DC power supply rated at 9~24V @ 500mA
- An access control panel with Wiegand input port or Data/Clock input port

### 1.3. Optional items

- A reader with Wiegand output port

## 2. Installing BioEntry™

### 2.1. Connecting wires

The BioEntry is connected to other devices of the security system through the pigtail cable at the rear side.

See Table 1 for wire colors and signals.

Wire color	Signal	Description
Shield (naked wire)	EARTH GND	Ground Earth
Blue with yellow tracer		Reserved
Black with white tracer	IN0	TTL IN 0
Black	IN1	TTL IN 1
Brown with white tracer	OUT0	TTL OUT 0
Brown	OUT1	TTL OUT 1
Red with white tracer	IO_GND	GND, for IO signals
Red	DCO_STRB	Data/Clock Output, Strobe
Orange with white tracer	WO_GND	Wiegand Output, GND
Orange	WO_VREF	Wiegand Output, VREF
Yellow with red tracer	WO_D0	Wiegand Output, Data 0 or Data/Clock Output, Card Present
Yellow	WO_D1	Wiegand Output, Data 1 or Data/Clock Output, Data
Green with white tracer	WI_D0	Wiegand Input, Data 0
Green	WI_D1	Wiegand Input, Data 1
Blue with white tracer	COM_GND	Comm. GND (for RS-232C)
Blue	WI_GND	Wiegand Input GND
Violet with white tracer	RX2	Receive data, RS-232C level
Violet	TX2	Transmit data, RS-232C level
Gray with red tracer	RX+	RX+, RS-485 level
Gray	RX-	RX-, RS-485 level
White with red tracer	TX+	TX+, RS-485 level
White	TX-	TX-, RS-485 level
Green with yellow tracer	POW_GND	Power GND
Red with yellow tracer	POW+	Power Input

**Table 1> BioEntry wire colors**

Warning: Care should be taken identifying the wires. Improper wiring may render permanent damage to the device or personal injury.

## 2.2. Power connection

Use 'POW+' and 'POW\_GND' wires to connect BioEntry to a DC supply, rated at 9~24V, 500mA. The power cable should be as short as possible to minimize wire resistance and emissions.

For optimum ESD resistance and safety, please make proper connection of 'Earth GND'.

For compliance with FCC and CE regulations, a good connection of earth ground should be made, and an additional ferrite core should be installed to supply lines. The installation of this ferrite core is mandatory for FCC and CE under R&TTE directive. Refer to Figure 1 for installation details.

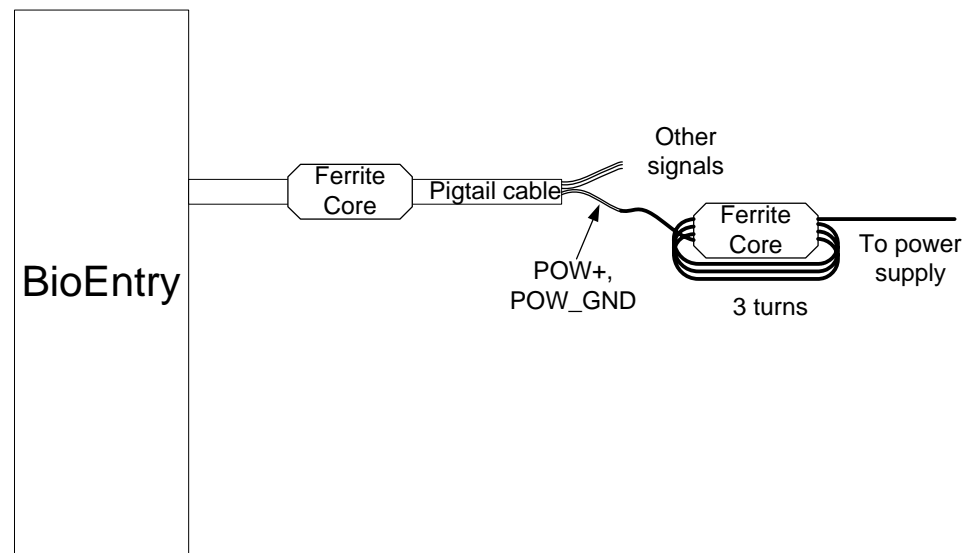

**Figure 1> Power connection**

## 2.3. Connecting to a Wiegand compatible reader

The BioEntry supports Wiegand compatible readers of various formats, including 26bit standard.

Connect 'WI\_D0', 'WI\_D1' and 'WI\_GND' wires to 'Data 0', 'Data 1' signals and signal ground of the Wiegand reader, respectively. The input signals can tolerate voltages up to 12V dc.

## 2.4. Connecting to a Wiegand compatible access controller

The BioEntry supports a flexible Wiegand output interface for most access controllers with Wiegand input ports.

Connect 'WO\_D0', 'WO\_D1' and 'WO\_GND' wires to 'Data 0', 'Data 1' signals and signal ground of the access controller, respectively. If the access controller's input signal level exceeds 5.0V, apply required voltage to 'WO\_VREF' to obtain higher voltage output signals. Be cautious not to connect 'WO\_VREF' directly to a power supply, especially when the source is below 5Vdc. Use a diode and a current limit resistor of a few hundred ohms in series to prevent excessive currents and damages of the device.

However, 'WO\_VREF' signal can be safely left unconnected as most access controllers accept 5V Wiegand signals.

## 2.5. Connecting to a Data/Clock compatible access controller

The BioEntry supports a Data/Clock output interface for access controllers with Data/Clock input ports. The output format is ABA track II. Refer to the operation manual for configuration and format details.

The Data/Clock interface shares signals with Wiegand Output port. If the port is configured as Data/Clock interface, 'WO\_D0' acts as card present signal, and 'WO\_D1' outputs data synchronized with additional 'DCO\_STRB' signal, which is the data strobe. Connect 'WO\_D0', 'WO\_D1', 'DCO\_STRB' and 'WO\_GND' wires to 'Card Present', 'Data', 'Strobe' signals and signal ground of the access controller, respectively.

## 2.6. Connecting to the host PC

The BioEntry provides various means to connect to the host PC such as: being a part of the RS-485 network, direct connection with RS-232C interface, and an auxiliary port for laptops. These interfaces are internally multiplexed, so only one interface should be connected. It is not supported using two or more interfaces simultaneously.

### 2.6.1. Connecting via RS-232C interface

Connect 'RX2', 'TX2' and 'COM\_GND' wires to 'TX', 'RX' and signal ground of PC's serial port.

### 2.6.2. Connecting via RS-485 interface for a full duplex BioEntry network system

Use 'RX+', 'RX-', 'TX+', and 'TX-' signals to join a full duplex BioEntry network.

For a full duplex network, two pairs of twisted wires in a shielded cable is needed.

Each signal in all BioEntry devices of the BioEntry network system should be

connected forming a multipoint network. As the PC is the master of the network system, connect 'TX+' and 'TX-' signals of the computer to 'RX+' and 'RX-' of BioEntry signals, and vice versa(See Figure 2).

At each end of the network, termination resistors of 120ohms should be connected between '+' and '-' signals for proper impedance matching.

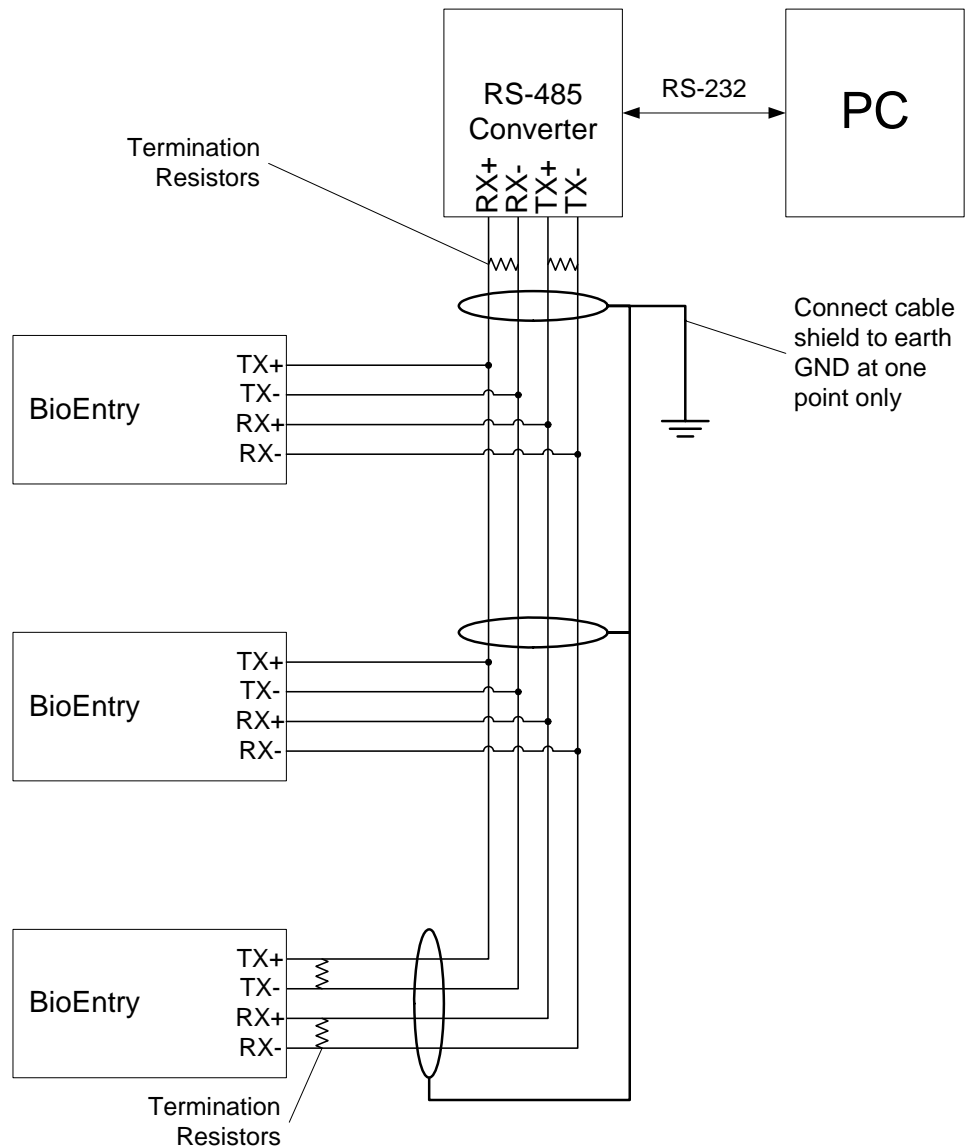

**Figure 2> A full duplex BioEntry network**

Warning: To prevent ground loops and avoid communication problems, connect cable shield to earth GND at only one point.

- 2.6.3. Connecting via RS-485 interface for a half duplex BioEntry network system
- For a half duplex network, a pair of twisted wires in a shielded cable is needed. For every devices in the half duplex network, tie 'TX+' with 'RX+' and 'TX-' with 'RX-' locally before connecting to the network(See Figure 3).
- At each end of the network, termination resistors of 120ohms should be connected between '+' and '-' signals for proper impedance matching.

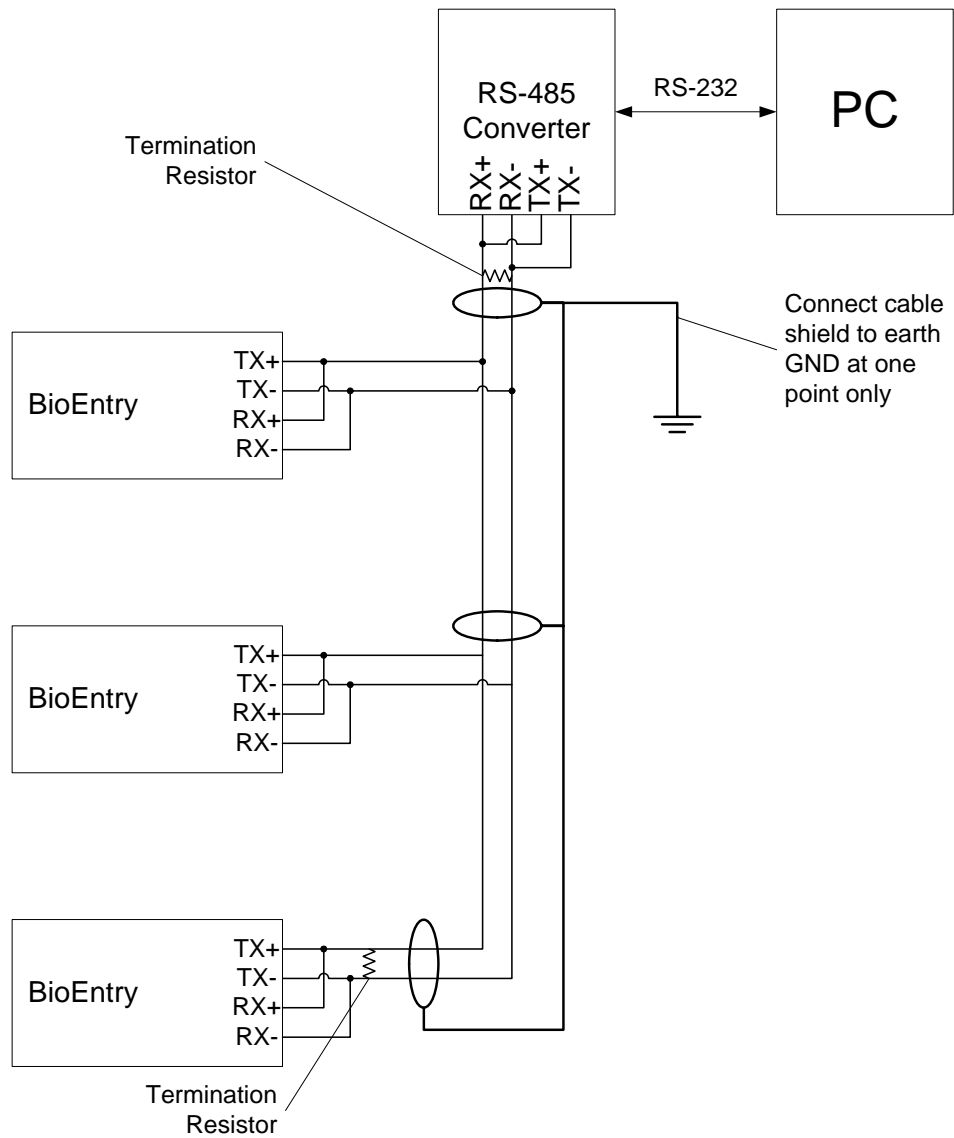

**Figure 3> A half duplex BioEntry network**

Warning: To prevent ground loops and avoid communication problems, connect cable shield to earth GND at only one point.

#### 2.6.4. Connecting via auxiliary interface

BioEntry™ series provide an auxiliary port to support connection to laptops, even if the device is not networked during installation. The user can access and manage the device with standard RS-232C port.

This port is internally multiplexed with RX2 and TX2 signals in the pigtail cable, and can be disabled for improved security.



**Figure 4> Connecting stereo plug to DB-9 cable**

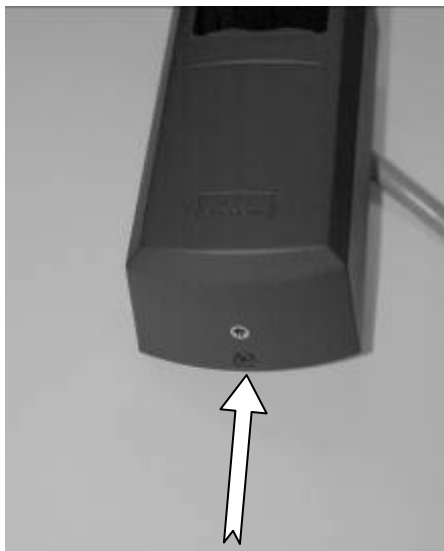

**Figure 5> Auxiliary port**

As shown on the Figure 6, to control the auxiliary port functionality for security



reasons, the BioEntry provides a slide switch to isolate the port electrically. By default, this switch is in down position to enable the port. To disable the port, slide up the switch with a small screw driver or a pen.

If the stereo plug is plugged into this port while the switch is enabled, the RX2 and TX2 signals in the pigtail cable are disconnected from the system. This feature is implemented to avoid signal conflicts between two interfaces. However, if the switch is disabled, the RX2 and TX2 signals remain connected regardless of the auxiliary port status.

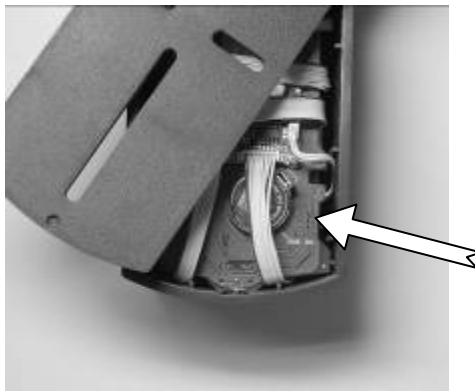

**Figure 6> Aux. enable switch**

## 2.7. Disassembling

Remove screw at bottom of the BioEntry.



**Figure 7> Removing the screw**

Lift bottom of the housing, slide up and carefully remove it.



**Figure 8> Separating the case**

## 2.8. Mounting back plate

Install back plate to wall surface.



**Figure 9> Installing back plate to the wall**

## 2.9. Reassembling the BioEntry



**Figure 10> Reassembling the case**

## 2.10. Installing the BioEntry™ Admin software

Carefully read the Operation Manual.

### 3. Examples for BioEntry™ installation

BioEntry™ Smart/Pass offers various interfaces such as Wiegand input/output, general purpose I/O signals and communication ports that can be easily implemented to a security system, improving the security level.

#### 3.1. Building a new system

BioEntry™ Smart/Pass is compatible with most access controllers with Wiegand interface. Building a new access control system with BioEntry is as simple and easy as with conventional Wiegand readers. In this section, the system with a BioEntry only configuration is explained. The minimal configuration for BioEntry installation is illustrated in Figure 11.

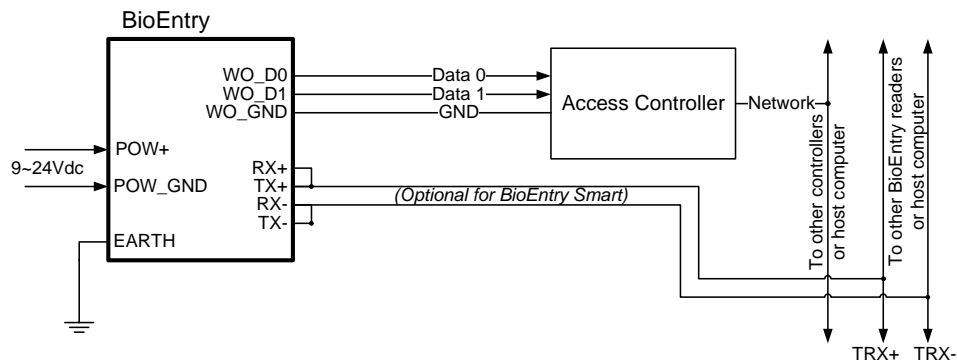

**Figure 11> BioEntry connection diagram**

##### 3.1.1. Installing BioEntry Pass

BioEntry™ Pass series operates in 1:N matching mode, and stores up to 9000 fingerprint template data into internal flash memory, which is more than enough for most applications. The access control system is secured with Suprema's fast and reliable 1:N matching algorithm.

The user enrollment process is performed in the administrator's computer, and the biometric data is distributed to each reader over the BioEntry Network.

##### 3.1.2. Installing BioEntry Smart

BioEntry™ Smart series stores user's fingerprint data in smartcards, easing user management and simplifying installation issues.

The user enrollment process is performed in the administrator's computer. The biometric data is stored in the smartcard which every user holds, instead of

distributing it to each reader over the network. This simple architecture greatly simplifies user management process and improves overall security, as the biometric data are physically isolated from the BioEntry, protecting them against possible vandalism. Moreover, as the user management process does not rely on network installation, total cost for installation is minimized.

### 3.2. Adding BioEntry to existing access control system

Access control systems using Wiegand readers for user identification can be upgraded by adding BioEntry Pass between Wiegand reader and access controller for improved security over a legacy proximity card based identification system. The BioEntry Pass is configured to work in 1:1 matching mode.

In this mode, user identification is performed in the following order:

- The user places the proximity card on the Wiegand reader to initiate the identification process.
- The Wiegand reader passes the user's ID to the BioEntry Pass through Wiegand port.
- The BioEntry Pass captures the user's fingerprint, and performs 1:1 matching with the user's fingerprint template data stored in the flash memory.
- If the captured fingerprint and the one stored in the flash memory match, the BioEntry Pass sends the user's ID to the access controller as if it were a Wiegand reader.
- The access controller process the user ID for further authentication.

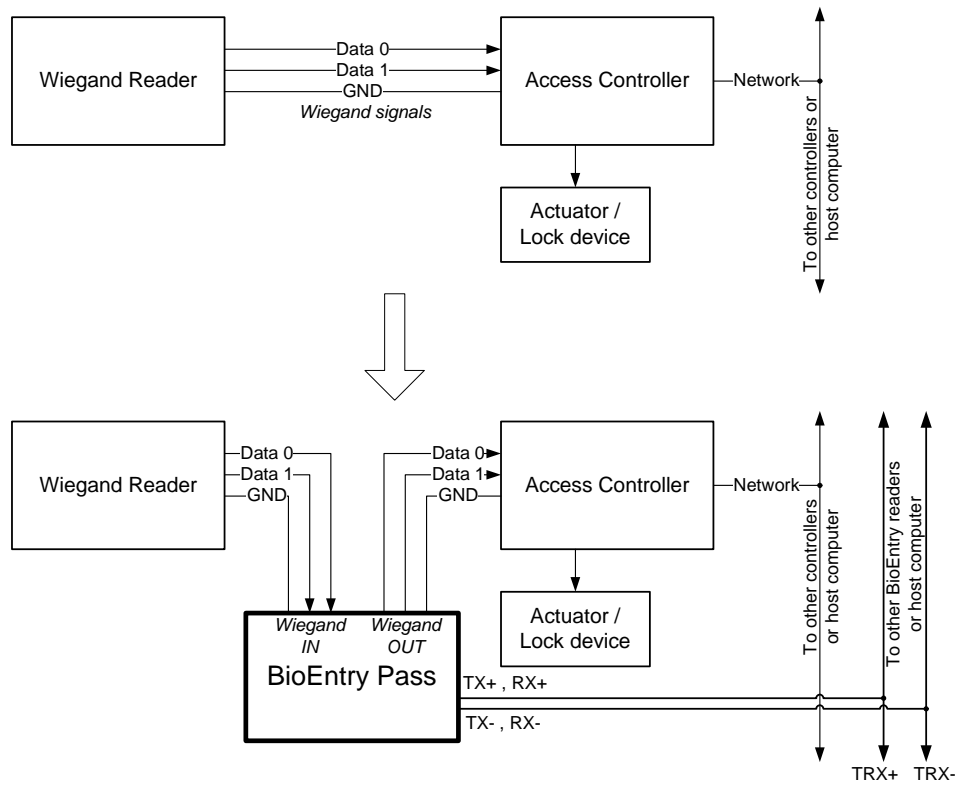

**Figure 12> Adding BioEntry Pass to existing system**

## 4. Specifications

### 4.1. Fingerprint authentication specifications

#### 4.1.1. Fingerprint authentication performance

EER*	<0.1%
Enrollment time	<1 sec
Verification time	<1 sec

\*EER is dependent on specific database

#### 4.1.2. Fingerprint sensor specifications

Model	BioEntry OP	BioEntry TC	BioEntry FC
Device Name	Suprema Optical sensor I	UPEK TouchChip TCS1CD	Atmel Fingerchip AT77C101B-CB02
Sensor technology	Optical	Capacitive	Thermal
Capture method	Touch	Touch	Swipe
Sensing area	16.0mm x 19.0mm	12.8mm x 18.0mm	14.0mm x 0.4mm
Image size(pixels)	272x320	256x360	360 x 500
Image resolution	500 dpi	508 dpi	500 dpi

#### 4.1.3. Data storage

Template capacity	9,000 at 4M Flash ( 19,000 at 8M )
LOG capacity	12,800 event

## 4.2. Mechanical specifications

### 4.2.1. Operating range

Parameter	Symbol	Min	Max	Units
Supply voltage	$V_{IN}$	9	24	V
Operating temperature (TC,OP)	$T_{OP}$	0	70	°C
Operating temperature (FC)	$T_{OP}$	-20	70	°C
Humidity (non-condensing)			85	%

### 4.2.2. Absolute maximum ratings

Parameter	Symbol	Min.	Max.	Units
Power supply voltage	$V_{DD}$	-0.3	28	V

Input voltage on Wiegand Input pins	$V_{IN}$	-0.3	14	V
-------------------------------------	----------	------	----	---

#### 4.2.3. Electrical DC characteristics

Parameter	Symbol	Min	Typ.	Max	Units
Supply current	$I_{DD}$		200	500	mA
<b>Wiegand Input Port</b>					
	Symbol	Min	Typ.	Max	Units
High level input voltage	$V_{WIH}$	3.3		12	V
Low level input voltage	$V_{WIL}$	-0.3		2.0	V
<b>Wiegand Output Port</b>					
	Symbol	Min	Typ.	Max	Units
High level output voltage	$V_{WOH}$		5.0	12	V
Low level output voltage	$V_{WOL}$		0.0		V
Current source/drain	$I_{WO}$		-1/20		mA
<b>TTL Input Port</b>					
	Symbol	Min	Typ.	Max	Units
High level input voltage	$V_{IH}$	2.0		5.5	V
Low level input voltage	$V_{IL}$	-0.3		0.8	V
<b>TTL Output Port</b>					
	Symbol	Min	Typ.	Max	Units
High level output voltage	$V_{OH}$		5.0		V
Low level output voltage	$V_{OL}$		0.0		V

#### 4.3. Smart card specifications

Parameter	Value
Antenna type	PCB loop antenna (60mm x 57mm)
Connection with transceiver	Permanent
Manufacturer / Model	Dual I, DE-KTFMI
Operating Frequency Range	13.553 ~ 13.567MHz
Duty cycle	100%

#### 4.4. Material information

Component	Material / Model	Manufacturer
PCB	FR-4,	Doosan Electronics
Enclosure	ABS, HF-380	LG Chem, Ltd.
Battery	CR2032	Hitachi Maxell, Ltd.

#### 4.5. RTC battery specification

Parameter	Value
-----------	-------



---

Model	CR2032
Manufacturer	Hitachi Maxell, Ltd.
Nominal Voltage	3 V
Nominal Capacity	210mAh
UL Recognition	MH12568(N)
Temp. range	-20 ~ +85°C

## 5. Certification information

### 5.1. CE

The BioEntry devices are compliant with CE under the R&TTE Directive.

The user should install proper earth ground wiring and ferrite core as stated in Section 2.2 to meet this directive.

### 5.2. FCC

This equipment has been tested and found to comply with the limits for a Class B digital device, pursuant to Part 15 of the FCC Rules. These limits are designed to provide reasonable protection against harmful interference in a residential installation. This equipment generates, uses, and can radiate radio frequency energy and, if not installed and used in accordance with the instruction manual, may cause harmful interference to radio communications. However, there is no guarantee that interference will not occur in a particular installation. If this equipment does cause harmful interference to radio or television reception, which can be determined by turning the equipment off and on, the user is encouraged to try to correct the interference by one or more of the following measures:

- Reorient or relocate the receiving antenna
- Increase the separation between the equipment and receiver
- Connect the equipment into an outlet on a circuit different from that to which the receiver is connected
- Consult the dealer or an experienced radio/TV technician for help

The user should install proper earth ground wiring and ferrite core as stated in Section 2.2 to meet the rules.

## Contact Information

**Suprema Inc.**

16F Parkview Office Tower, Jeongja-dong, Bundang-gu,  
Seongnam, Gyeonggi, 463-863 Korea

**Tel:** +82-31-783-4502

**Fax:** +82-31-783-4503

**Website:** <http://www.supremainc.com>

**Sales inquires:** [sales@supremainc.com](mailto:sales@supremainc.com)

**Technical inquires:** [support@supremainc.com](mailto:support@supremainc.com)