

ICARUS

I - Motoriduttore elettromeccanico per porte basculanti e sezionali

GB - Electromechanical gearmotor for sectional and overhead garage doors

E - Motorreductor electromecánico para puertas levadizas y seccionales

CE



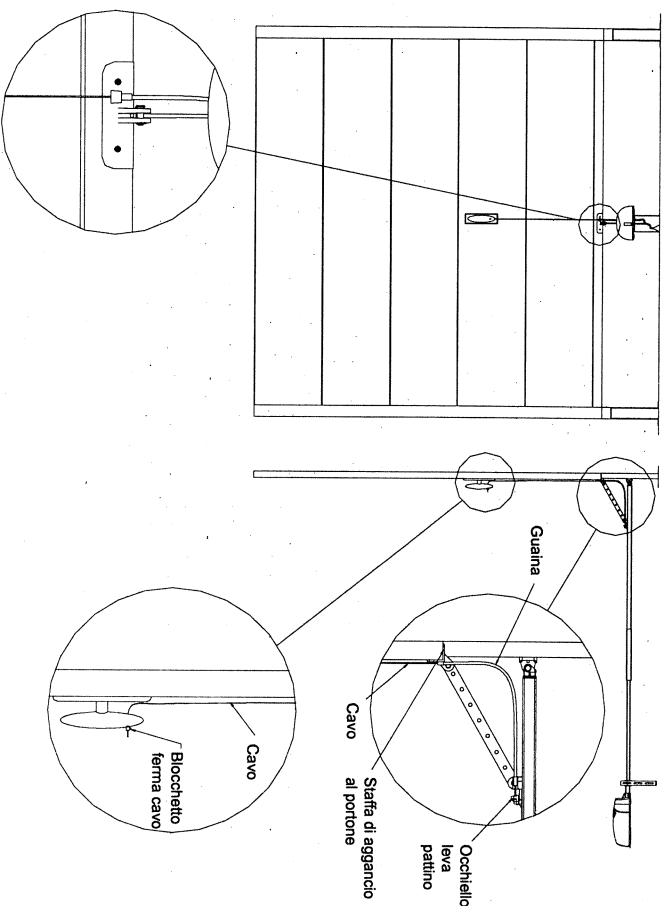

MANUTENZIONE

- Le operazioni di manutenzione e in particolare l'accesso alle parti interne del motoriduttore ICARUS, compresa l'eventuale sostituzione della lampada di cortesia, devono essere svolte solo ed esclusivamente da personale qualificato
- Controllare periodicamente che tutte le viti di fissaggio del sistema di ancoraggio e di trazione del motoriduttore, non siano allentate.
- Controllare periodicamente il funzionamento dei dispositivi di sicurezza.
- Controllare periodicamente la bilanciatura della porta
- **Controllare periodicamente la pulizia dei denti dell'ingranaggio motore, per evitare letture errate da parte dell'encoder.**
- La centralina è dotata di un contattori interno per segnalare il raggiungimento, da parte dell'automazione, di un numero di cicli importante per quanto riguarda la manutenzione e più esattamente avremo che:
 - a) la centralina segnalerà il raggiungimento degli 5000 cicli provocando un lampeggio da parte della luce di cortesia di termine di ogni ciclo successivo agli 5000.
 - b) La centralina segnalerà il raggiungimento degli 5200 cicli provocando 3 lampeggi da parte della luce di cortesia al termine di ogni ciclo successivo agli 5200.

ACCESSORI OPZIONALI

- Ricevitore ad autoapprendimento da 433,92 MHz o da 868,35 MHz da integrare sulla centralina elettronica.
- 2 batterie lampone da 12V 2,3Ah.
- Braccio adattatore per porte basculanti a contappesi.
- Sistema di sblocco a tune per l'azionamento manuale del portone dall'esterno.



WARNING I

- This instruction handbook is for qualified staff only and not for final users; nevertheless the installer must teach the user how to use the automation, inform them about possible dangers and the importance of a regular maintenance.
- The installation has to be carried out by qualified staff only and in compliance with the latest safety regulations in the automatic opening sector; particularly the installation has to comply with the 89/392 directive and the EN 12453 and EN12445 regulation.
- ICARUS has been developed for the automation of sectional and spring and counterweight overhead doors. The use of the product for unsuited purposes is strongly forbidden.
- Use only original spare parts. Stagnoli does not take upon any responsibility for damages caused by the inappropriate use of non-original components.
- Make sure that the garage ceiling and walls are strong and stable, please pay attention to install the operator in a bump free area.
- Make sure that the garage door frame is solid and suitable to be motor driven.
- Make sure that the door is friction free.
- The door must be properly balanced.
- Before and during installing make sure that the power supply is off.
- Choose the safety devices to be installed very carefully, moreover do not forget to add an emergency stop device to cut off the power supply.
- Connect the power supply cable only to adequately protected plugs; please install a device for the disconnection of every single pole from the electric network by leaving a space of at least 3.5 mm between each contact.
- In case of a sectional or overhead garage door with built-in side door, the automation must stop when opening the side door (for ex. install a micro-switch in the side door frame and connect it to the Stop input on the control board).
- The Irreversible gearmotor avoids installing an electric lock and in case of black-out the release allows the gate to be easily opened and closed.

ITEM DESCRIPTION

The ICARUS electromechanical gearmotor by Stagnoli has been developed for the automation of sectional and spring and counterweight overhead garage doors. ICARUS is available in two different versions according to the gearmotor max. traction power (600 N or 1000 N) and to the max height of the door (max. 2.100 - 2.300 or 2.500 mm). The ICARUS gearmotor has an extremely compact motor casing and base plate to house both the gearmotor and the central control unit. Icarus is not provided with a limit switch cam as it has a built-in optical encoder. A 433,92 Mhz or 868,35 Mhz self-learning receiver can be built in the central control unit (optional). The structure of the casing allows easy access to the central control unit with built-in courtesy lamp. The electromechanical ICARUS gearmotor can be managed with an external push button situated on the casing, moreover Icarus does not fear black-outs as it has a manual block releaser and first-aid batteries (optional).

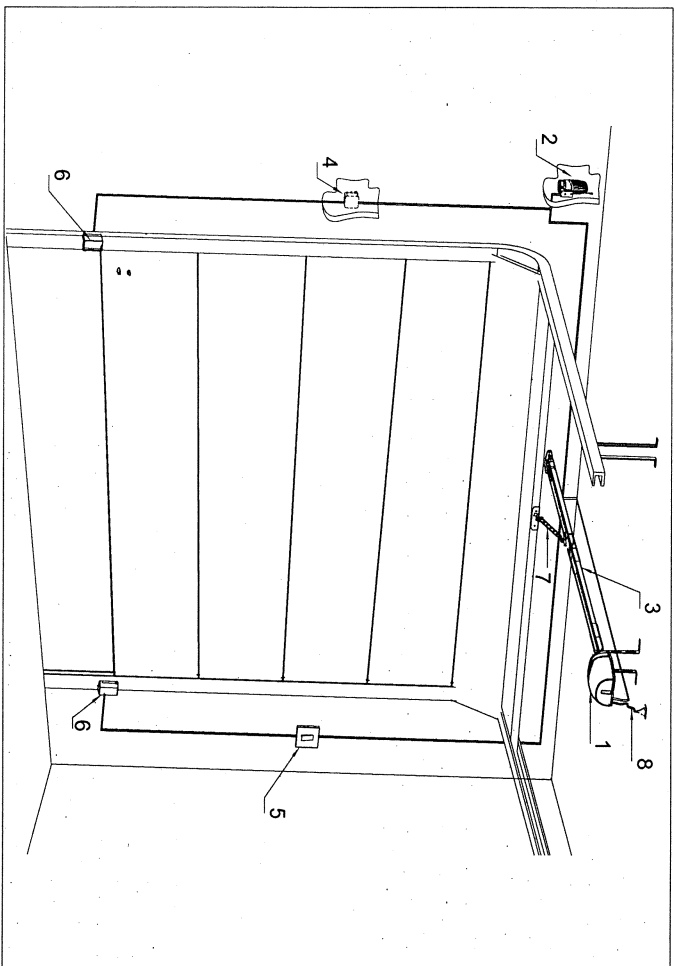

Pic. 1: general installing scheme

1. ICARUS electro-mechanical gearmotor.
2. Pegasus blinker (out-door): 2 X 1 mm²
3. Sliding rail.
4. Key pad (out-door): 3 X 0,5 mm²
5. Push-button: 2 X 0,5 mm²
6. Photocells: 2 X 0,5 mm² (TX); 4 X 0,5 mm² (RX)
7. Straight arm.
8. Supply cable: .H05VV-F 2 x 0,75 mm²



- For low voltage connection devices, use double-coating cables.
- To abide to "low voltage safety standards" (EN 60335-1) 230V single-coating connecting cables must have an additional 1 mm thick coating with at least 4 mm distance from low voltage ones.
- Outgoing cables from the gearmotor must be secured with stop cable connectors with 0,5 N torque wrench setting or use connection raceways to avoid connecting cable tearing.

TECHNICAL FEATURES AND INSTALLATION INSTRUCTIONS

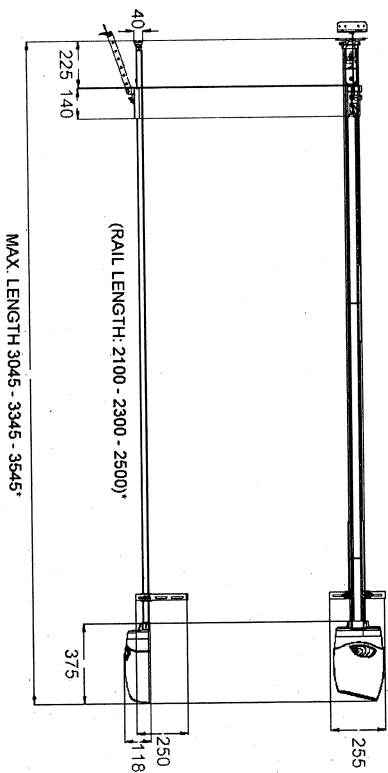

	ICARUS 600	ICARUS 1000
Power supply	230V ~ (50Hz)	230V ~ (50Hz)
Max. Absorption	1 A	1.3 A
Max. Power	200 W	275 W
Motor supply	24 Vdc	24 Vdc
Max. rail length (mm)	2.100 - 2.300 - 2.500	2.100 - 2.300 - 2.500
Speed (m/min)	9,3	9,3
Max. force (N)	600	1000
Working temperatures	-20 °C; +70 °C	-20 °C; +70 °C
Max. Working Time (tw ₂)	4 min.	6 min.
Weight (kg)	12,2 - 12,9 - 13,4	12,8 - 13,5 - 14

Limiti d'impiego	ICARUS 600	ICARUS 1000
Overhead door ≤ 80 Kg Max. 2200 X 2500 mm (H x L)	X	
Sectional door ≤ 80 Kg Max. 2300 X 3000 mm (H x L)	X	
Overhead door ≤ 150 Kg Max. 2300 X 4000 mm (H x L)		X
Sectional door ≤ 150 Kg Max. 2300 X 5000 mm (H x L)		X
Sectional door ≤ 150 Kg Max. 2400 X 4500 mm (H x L)		X
Sectional door ≤ 150 Kg Max. 2500 X 4000 mm (H x L)		X



GB - Electromechanical gearmotor for sectional and overhead garage doors

INSTALLATION

The assembling kit contains:

- ICARUS electromechanical gearmotor (1).
- A galvanised cold-formed plate sliding rail, two rails with fix length of 1170 mm (2) and the third one (3) in 460, 760, or 960 mm of length according to the gearmotor version.
- Two steel rail junctions (4).
- An emergency block release (5).
- A stroil arm (6).
- A chain (7).
- Two wall brackets (8).
- A chain tension system (9).
- A wall bracket (10).
- A rail support assembly (11).
- Chain blocking support (12).

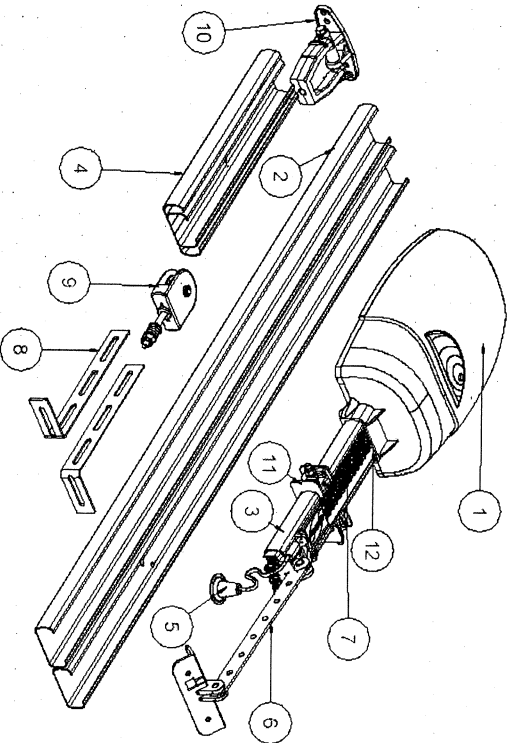

Before listing the different installation procedures of the ICARUS electromechanical gearmotor we would like to stress again some fundamental warnings for a correct use of the device:

1. **The door has to be well balanced.**
2. **Make sure that the garage ceiling and walls are strong and stable, please pay attention to install the operator in a bump free area.**
3. **Make sure that the garage door frame is solid and suitable to be motor driven.**
4. **Make sure that the door is fiction free.**

GB - Electromechanical gearmotor for sectional and overhead garage doors

The assembling of the ICARUS electro-mechanical gearmotor envisages the following procedures:

1. Assemble the rail with the steel profiles and junctions and extend the chain throughout the hole length of the rail (before extending the chain remove the chain blocking support).

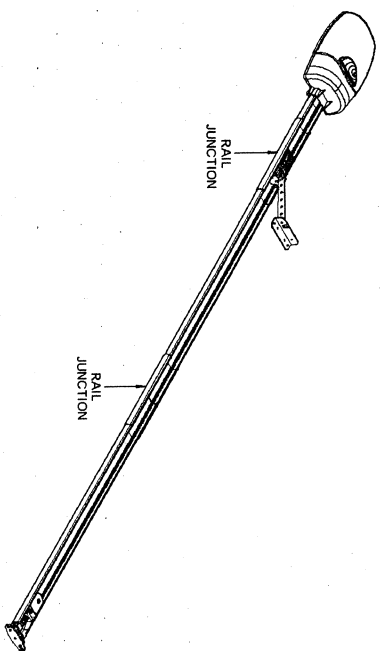

2. Tighten properly the chain by screwing the nut.

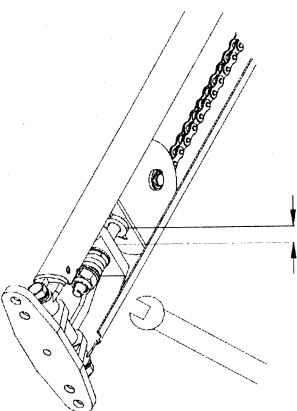

3. Tighten the support brackets to the rail support assembly on the rail.

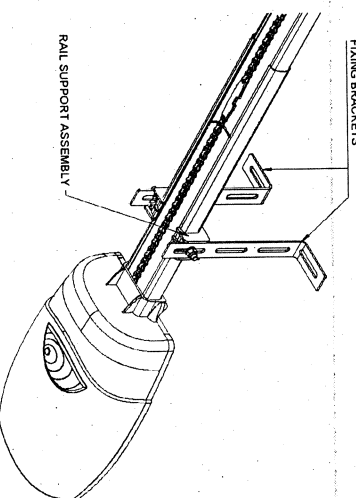

GB - Electromechanical gearmotor for sectional and overhead garage doors

4. Fix the guide supporting bracket centrally to the wall with the screws and rivets provided by leaving a min. 20 mm space (from the door highest point), finally fix the straight arm centrally to the door (for sectional and spring overhead doors).

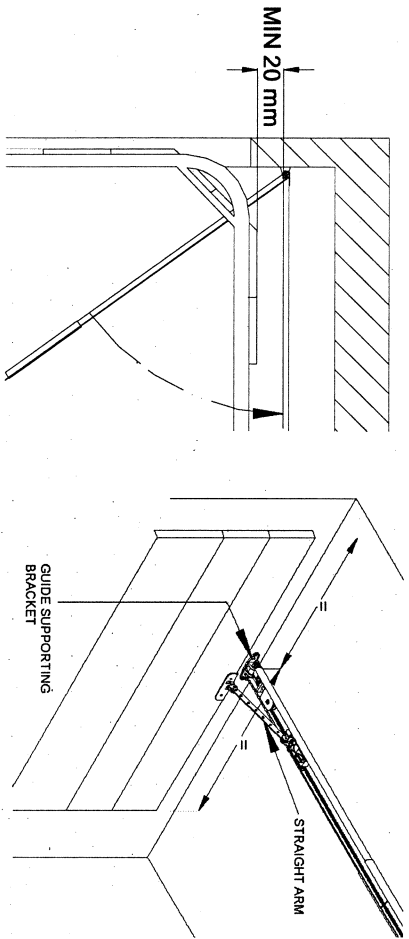

- 4.2 Check the max. sliding point of the overhead door and fix the guide supporting bracket by leaving a min. 20 mm space from the door highest point. Finally fix the straight arm to the oscillating arm (for counterweight overhead doors).

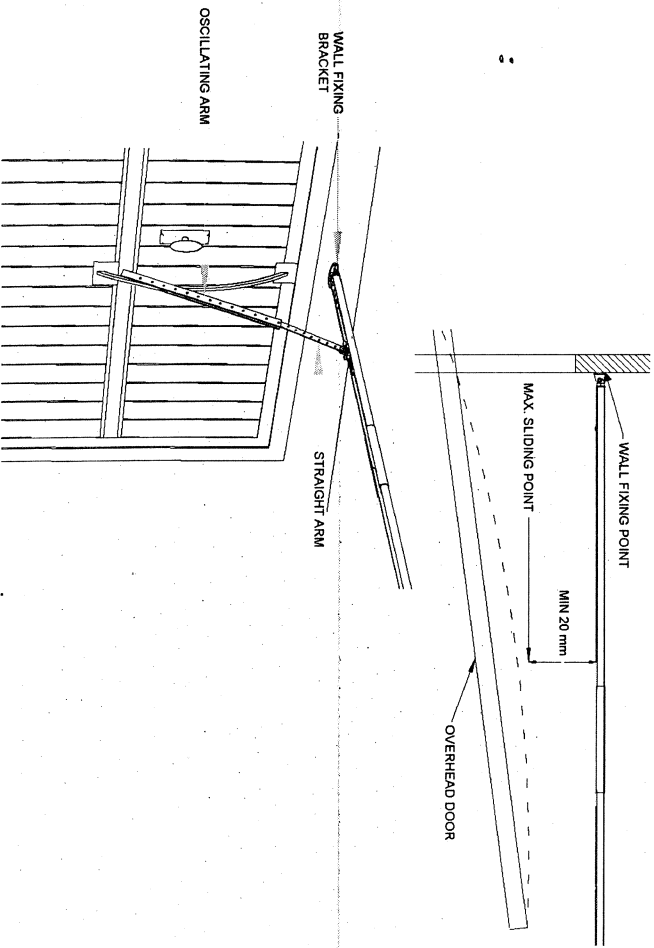

GB - Electromechanical gearmotor for sectional and overhead garage doors

5. Fix the rail and the gearmotor to the ceiling through the fixing brackets (with max. 220 mm space) so that the device is fully levelled and well centred.

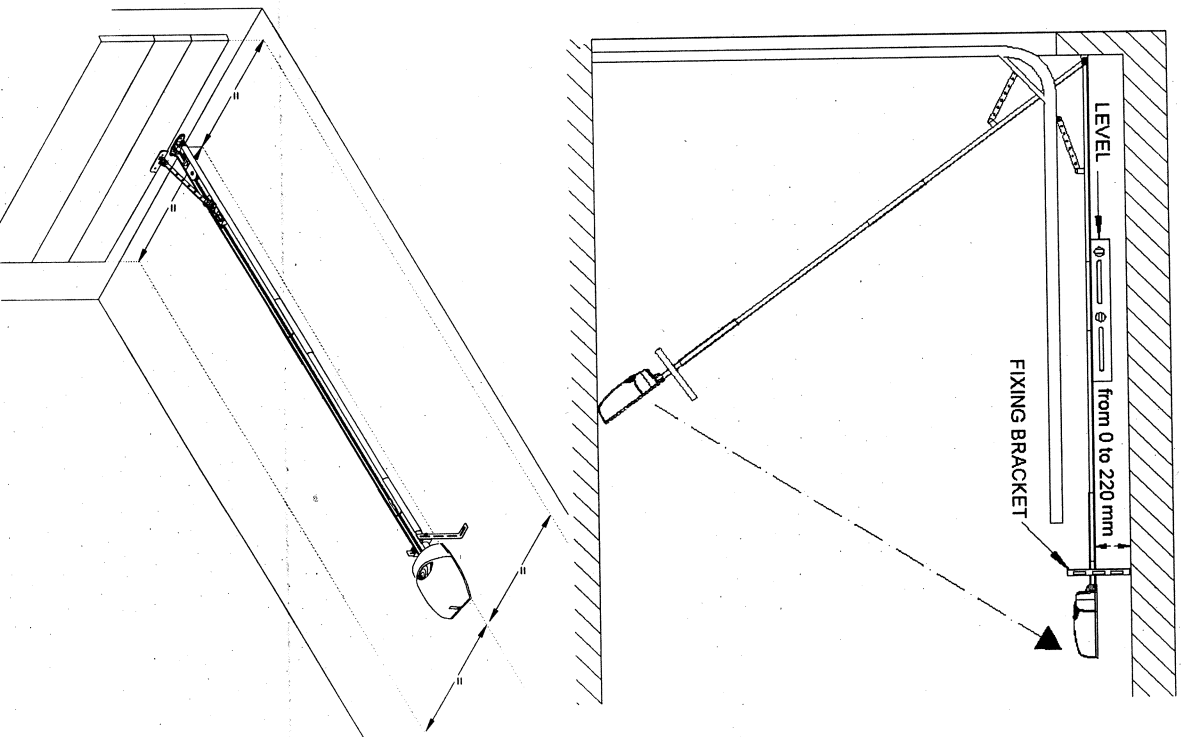

GB - Electromechanical gearmotor for sectional and overhead garage doors

MANUAL CONTROL

The ICARUS gearmotor has a manual release that moves the door independently from the automation, so that the door can be manually opened in case of power supply break-out. Pull the knob downwards to release the operator. Stagnoli provides an outside release system with knob and rope as optional accessory.

Outside release system

overhead garage doors

Fix the two cable and sheath holder squares: insert the ends of the sheath in their place on the slide and on the first bracket; insert the sheath, take the metal cable and thread it through the eye on the slide lever; insert it in the squares, threading it through the handle (already perforated) and lock it with the clamp that loads the slide spring. By turning the handle from 90° to 180° the geared motor is released.

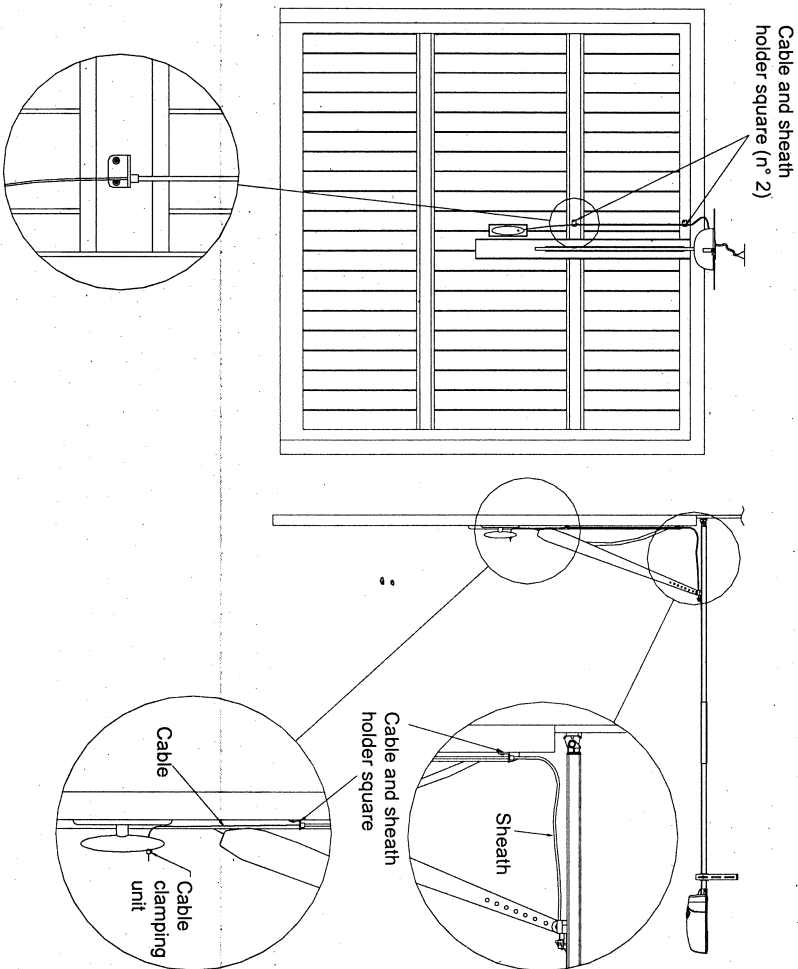

GB - Electromechanical gearmotor for sectional and overhead garage doors

Sectional doors

Insert the ends of the sheath in their place on the slide and on the door fastening bracket; insert the sheath, take the metal cable and thread it through the eye on the slide and then through the bracket; lastly, thread it through the handle (already perforated) and lock it with the clamp, loading the slide spring. By turning the handle from 90° to 180° the geared motor is released.

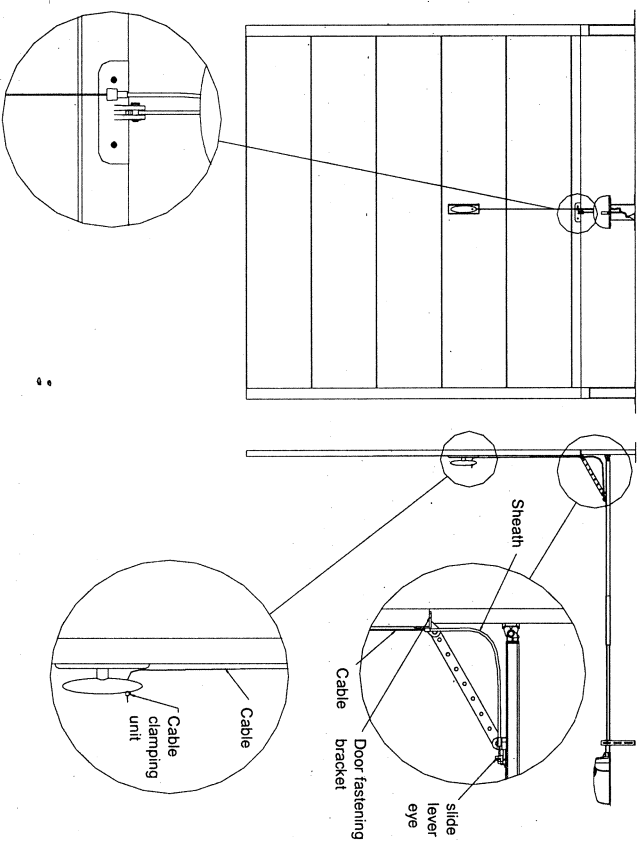

MAINTENANCE

- **Maintenance services - as well as contact with the inner components of the ICARUS gearmotor or simply courtesy lamp change - must be carried out by qualified staff only.**
- Check regularly all fixing screws of the roll and operator.
- Check regularly all safety devices.
- Check regularly the door balancing.
- **Gear motor teeth should be checked and cleaned regularly to allow the perfect working of the encoder**
- The central control unit has a built-in cycle counter that advises when the service inspection is required:
 - a) By 5,000 openings the courtesy lamp blinks after each opening.
 - b) By 5,200 openings the courtesy lamp blinks 3 times after each opening.

OPTIONAL ACCESSORIES

- 433.92 MHz or 868.35 MHz built-in self-learning receiver.
- Two 12V 2.3Ah batteries.
- Oscillating arm for counterweight overhead garage door.
- Outside release system with knob and rope.