

Alarm Control Panels

INTEGRA

Firmware Version 1.06

Satel 
GDAŃSK

INSTALLER MANUAL





WARNINGS

For safety reasons, the alarm system should only be installed by qualified personnel.

In order to avoid the risk of electric shock, read carefully this manual before proceeding to installation. Any connections should only be made in deenergized state, i.e. with power supply disconnected.

The control panel should be connected to **PSTN (analog) lines only**. Connecting the telephone circuit directly to digital network (e.g. ISDN) will cause damage to the equipment.

The alarm system may comprise dangerous devices, therefore it is necessary that its components be kept so as to prevent unauthorized access to the equipment.

If the service operations consist in fuse replacement, they must only be carried out with supply voltage disconnected. Only fuses having identical parameters with the original ones can be used for the replacement.



It is recommended that the manufacturer's prescribed housings and power supply units be used.

Making any construction changes or unauthorized repairs is prohibited. This applies, in particular, to modification of assemblies and components.

CAUTION!

It is impermissible to connect a fully discharged battery (with voltage on unloaded terminals less than 11 V) to the alarm panel. In order to avoid equipment damage, the fully discharged/never used battery should be precharged by means of a suitable charger.

The batteries used in the alarm systems contain lead. When used-up, the batteries must not be thrown away, but disposed of as required by the existing regulations (European Directives 91/157/EEC and 83/86/EEC).

DECLARATION OF CONFORMITY		
Products: CA424P, CA832, CA16128P - mainboards of INTEGRA control panels. - INTEGRA 24 - INTEGRA 32 - INTEGRA 64 - INTEGRA 128	Manufacturer: SATEL spółka z o.o. ul. Schuberta 79 80-172 Gdańsk, POLAND tel. (+48 58) 320-94-00 fax. (+48 58) 320-94-01	
Product description: Mainboards for alarm control panels intended for use in intruder alarm systems.		
These products are in conformity with the following EU Directives: LVD 73/23/EEC+93/68/EEC EMC 89/336/EEG + 91/263/EEC, 92/31EEC, 93/68/EEC R&TTE 1999/5/EC (network connection, TBR21)		
The product meets the requirements of harmonized standards: LVD: EN 50131-1:1997; EN 50131-6:1997; EN60950:2000, EN60335-1:1994/A1:1996 Annex B EMC: EN 55022:1998; EN 61000-3-2/-3; EN 50130-4:1995, EN 61000-4-2/-3/-4/-5/-6/-11 R&TTE: TBR 21(1998)		
Gdańsk, Poland	07.03.2005	Head of Test Laboratory: Michał Konarski 
Latest EC declaration of conformity and product approval certificates are available for downloading on website www.satel.pl		

The INTEGRA alarm control panels meet requirements as per CLC/TS 50131-3, Grade 3, and have been certified by Det Norske Veritas Certification AS, Norway.

New functions of the INTEGRA control panels in version 1.06

Expansion modules	Support for a new module: <ul style="list-style-type: none">- INT-RS – converter for monitoring events by means of a special external device, integration of the control panel with other systems (e.g. so-called smart house) or connecting a computer with installed GUARDX program in the same way as to LCD keypad. Support for ABAX ACU-100 wireless system controller with firmware version 1.07 and 2.0.
--------------------------	---

CONTENTS

1.	Introduction	3
2.	General Features of Control Panels.....	3
3.	System Components.....	5
3.1	Mainboards	5
3.2	LCD keypads	6
3.3	Optional modules	6
3.3.1	Modules to be connected to keypad bus.....	6
3.3.2	Modules to be connected to expander bus	7
4.	System installation	9
4.1	Installation plan	9
4.2	Estimation of system current consumption	9
4.3	Cabling.....	9
4.4	Installation of control panel mainboard	10
4.5	Connecting LCD keypads and other devices to keypad bus.....	14
4.5.1	Addressing devices connected to keypad bus.....	16
4.5.2	Numeration of keypad zones	17
4.5.3	Keypad RS-232 port.....	18
4.6	Connecting devices to expander bus.....	18
4.6.1	Addressing devices connected to expander bus	20
4.7	Connection of detectors	22
4.8	Connection of sirens	26
4.9	Connection of telephone line	27
4.10	Connection of voice synthesizers	28
4.11	Connection of printer.....	28
4.12	Connection of power supply.....	29
4.12.1	Power supply connection procedure	30
4.13	Starting the control panel	30
5.	Compliance with CLC/TS 50131-3 requirements	31
6.	Basic specifications.....	32
6.1	Technical data – alarm control panels	32
6.2	Technical data – keypads	33
6.3	Technical data – expansion modules.....	34
6.4	Battery selection	35
6.4.1	INTEGRA 24 – battery 7 Ah.....	35
6.4.2	INTEGRA 32 – battery 7 Ah.....	35
6.4.3	INTEGRA 32 – battery 17 Ah.....	36
6.4.4	INTEGRA 64/128 – battery 17 Ah.....	36
7.	History of the manual updates	37

1. Introduction

This manual covers the INTEGRA 24, INTEGRA 32, INTEGRA 64 and INTEGRA 128 control panels. During installation, differences in technical parameters between particular main boards should be taken into account (see Table, page 5).

Devices incorporated in the INTEGRA alarm system meet requirements of the following standards: 50131-3, 50130-4, 50130-5 and 50131-6.

2. General Features of Control Panels

The INTEGRA series alarm control panels are designed for small, medium-size and large facilities. Irrespective of its dimensions, each of the control panels has identical, advanced functional capabilities. The alarm systems which are based on them can be without difficulty extended by using the same expansion modules for all these control panels. It also makes possible to easily replace the control panel with a bigger one, if it is required by development of the system. Owing to such a solution, the optimal control panel can be selected for the particular site. The INTEGRA alarm control panels not only guarantee a perfect protection of the facility against burglary; they also offer advanced functions of access control and automatic operation of a number of devices. At the same time, they are easy to operate and user-friendly.

The control panels are characterized by the following features:

- Firmware of the alarm control panel is stored in FLASH type non-volatile memory, so it can be easily updated with no need for dismounting of the panel. It only requires connection of the panel to the computer via RS-232 port and starting of the procedure of firmware replacement.
- Saving the control panel settings to FLASH memory. These data will be retained even if the RAM memory backup battery is disconnected.
- Possibility to divide the system into objects and 32 partitions (partition = group of zones). The partitions may be controlled by the user, timers, control zones, or their status may be dependent on the status of other partitions. It is possible to temporarily restrict the access to partitions.
- Possibility of system development by adding the expansion modules (the development extent depending on the control panel size). Creation of a system based on modules (including the wireless system controller of SATEL manufacture) installed at various places throughout the facility can considerably reduce the amount of cabling used.
- Possibility to store in the system from 16 to 240 passwords (codes), which may be either assigned to users or to control functions.
- Variety of means for security system control:
 - LCD keypad,
 - partition keypad,
 - proximity cards reader,
 - 433 MHz remote key fob (optionally, with INT-RX module installed),
 - 868 MHz remote key fob (optionally, with ACU-100 controller, with firmware in version 2.0 or later, connected),
 - computer with DLOADX or GUARDX program installed,
 - SMS message (optionally, with GSM-4S module connected),
 - web browser (optionally, with ETHM-1 module connected),
 - mobile phone with MobileKPD application installed (optionally, with ETHM-1 module connected),

- palmtop (PDA or MDA) with suitable application installed (optionally, with ETHM-1 module connected).
- Execution of the access control function by means of partition keypads, code locks and readers of proximity cards / DALLAS chips. Door status control by modules does not reduce the number of control panel supervision zones.
- Possibility to define the names of users and of majority of system components (partitions, zones, outputs, modules) which facilitates the control and monitoring of system as well as viewing of events log.
- Reporting events to two monitoring stations (four telephone numbers) by means of:
 - telephone line,
 - GSM voice channel (optionally, with GSM module connected),
 - GPRS (optionally, with GSM LT-2S or GSM-4S module connected),
 - SMS messages (optionally, with GSM LT-2S or GSM-4S module connected),
 - Ethernet network and TCP/IP protocol (optionally, with ETHM-1 module connected).
- The control panel makes possible monitoring in several formats, including Contact ID and SIA.
- Alarm messaging to telephones by means of voice messages or to a pager with text messages. Reception of a message can be acknowledged with a code entered from the telephone set keyboard (DTMF).
- Function of phone call answering, which enables checking the status of all control panel partitions and controlling the status of outputs. It is performed after user identification (each user may be assigned a special "telephone" password/code).
- Extended function of events printing, which enables the events to be sorted. Event descriptions are in accordance with the Contact ID standard. Besides, the names of zones, modules and users are printed as they are defined in the system.
- Additional function of the control panel RS-232 port, i.e. controlling the external analog modem, ISDN modem, GSM module, ISDN module and ETHM-1 module of SATEL manufacture, enables communication to be established with the service computer. In this case, the remote programming via telephone network or Ethernet as well as the service are as quick as direct programming from the computer via RS-232 port.
- Possibility of time-based control owing to timers that operate on week work cycle, with an option to define exception periods. Additionally, each partition is provided with its own timer (based on week or day cycle), programmed by the suitably authorized user, to secure automatic arming and disarming.
- Facilitated performance of non-standard functions due to a possibility to make complex logic operations at outputs.
- High-capacity event log where, in addition to the monitored events, also other events (like user access, functions used, etc.) are stored.
- Internal program structure allows to process all the incoming events. Because of the processing power, there's no need to individually prioritize particular signals.
- Shared indicators (like the LCD display) use the following display priority for the zone state (listed from highest to lowest priority): Bypass, Fault, Tamper Alarm, Intruder Alarm, Tamper violation, Intruder violation, Tamper memory, Intruder memory, Zone OK.

3. System Components

3.1 Mainboards

Show in the table below are technical parameters of the alarm systems based on particular control panels of the INTEGRA family.

Technical parameter (quantity)	INTEGRA 24	INTEGRA 32	INTEGRA 64	INTEGRA 128
Security Grade	3			
Available messaging options	A, B, C			
Zones, mainboard	4	8	16	16
Zones, system	24	32	64	128
High-current outputs, programmable, mainboard	2	2	4	4
Dedicated power outputs for keypads, expanders and detectors	3	3	2	2
Outputs, OC type, mainboard	2	6	12	12
Outputs, system	20+4*	32	64	128
Connectors for voice synthesizers	1	1	2	2
Keypads, system	4	4	8	8
Expander buses	1	1	2	2
Expanders, system	32	32	64	64
Zone expanders	2	3	6	14
Output expanders	2	3	6	14
Objects	1	4	8	8
Partitions	4	16	32	32
Timers	16	32	64	64
Telephone numbers for messaging	4	8	16	16
Pager messages	16	32	64	64
Voice messages	16	16	16	32
Remote switches	16	16	16	32
Users (w/o master user and service)	16	64	192	240
Event log	899	899	6143	22527
Power supply capacity [A]	1.2	1.2	3	3
Battery charging current [mA]	350	400/800	500/1000	500/1000
Current capacity, programmable outputs: high-current / OC [A]	2 / 0.05	2 / 0.05	3 / 0.05	3 / 0.05
Current capacity, power-supply outputs: +KPD / +EX1 with +EX2 [A]	-	-	2.5 / 2.5	2.5 / 2.5
+KPD / +EX / AUX [A]	0.5/0.5/0.5	0.5/0.5/0.5	-	-

* 20 physically available outputs (mainboard + expanders) + 4 virtual outputs (to perform logical functions – see description of output types 46 and 47).

- Zones programmed individually to handle configurations with or without end-of-line resistor (NO, NC, EOL, 2EOL/NO and 2EOL/NC) with functional test of the detector. The zone status may also depend on the output status (if this is the case, the selected output does not need to be physically connected to a zone, which enables virtual zones and outputs to be used in the system). One of a few dozens of response types can be chosen for each zone.

- High-current outputs with polymer fuses and low-current outputs designed to control relays, with a programmable operating mode and a possibility to select one of a few dozens functions.
- High-current outputs with polymer fuses having power supply output functionality.
- 1 or 2 connectors for voice synthesizers (SM-2 or CA-64 SM).
- Communication bus (keypad bus) for connection of LCD keypads and some of the additional modules.
- 1 or 2 communication buses (expander buses) for connection of additional modules to expand the mainboard functional capabilities. 32 or 64 such modules can be connected to the control panel.
- Telephone communicator, provided with a DTMF detection system for reception of commands via the telephone, as well as for monitoring, messaging, answering calls and remote programming.
- RS-232 port enabling the alarm system operation by means of a computer (DLOADX installer program), interfacing with a printer and the use of an external modem.
- Switching-mode power supply with short-circuit protection, provided with battery monitoring and discharged battery disconnection circuit.
- Independent real time clock with calendar, provided with its own back-up battery.
- Visual signaling of operation of all outputs, battery charging circuit and telephone communication unit.
- Electric protection of all zones, outputs and communication buses.

3.2 LCD keypads

The keypads interacting with INTEGRA control panels are made with or without a built-in proximity card reader. They have the following features:

- Large, easy to read 2x16 characters display with permanent or temporary backlighting activated on pressing a key or by any control panel zone.
- Keyboard with backlighting controlled in the same way as the display backlighting.
- 2 zones with properties identical to main panel zones.
- Microswitch for keypad tamper detection.
- RS-232 port enabling the alarm system to be operated by means of computer (GUARDX supervisory and user program).

3.3 Optional modules

The control panels are equipped with communication buses to allow for addition of expansion modules, which, along with the firmware updating feature to enhance their functionality, provides means for an easy upgrading of the system. It enables the system to be expanded by adding new components in order to better meet individual needs of the customer. The INTEGRA control panels interact with the CA-64 control panel dedicated modules, though some of them require a new program version.

3.3.1 Modules to be connected to keypad bus

CA-64 PTSA. Mimic Board. Enables visualization of the state of partitions/zones in the security system. The INTEGRA control panels support the mimic boards made in version CA64T v 1.4 and having firmware in version v4.0 or later.

ETHM-1. Ethernet Module. Makes it possible to operate the control panel through the Ethernet. INTEGRA control panels with firmware version 1.04 support ETHM-1 modules version 1.02 or later.

INT-RS. Data converter. Makes it possible to connect a computer with GUARDX program installed, similarly as to LCD keypad, monitor events by using a special external device, and operate the control panel by means of software other than that offered by SATEL.

3.3.2 Modules to be connected to expander bus

INT-S-GR/INT-S-BL/INT-SK-GR. Partition Keypad. Controls the armed mode in one partition; can perform the access control functions and operate the electromagnetic door lock.

INT-SCR-BL. Depending on its settings, the device can work as a **partition keypad** (identified as INT-S in the control panel), a **partition keypad with reader** (identified as INT-SCR in the control panel) or an **entry keypad** (identified as INT-ENT in the control panel). If it operates as a partition keypad or a partition keypad with reader, the device can control arming of one partition, execute access control functions, and control operation of the electromagnetic door lock. The main task of the entry keypad is activation the delay for zones with reaction type 3 INTERIOR DELAYED. After the time period programmed in the keypad has elapsed and the system has not been disarmed, the interior delayed zones will operate again as the instant ones.

INT-SZ-GR/INT-SZ-BL/INT-SZK-GR. Code Lock. Enables performance of the access control functions and operation of the electromagnetic door lock.

CA-64 SR. Expander of Proximity Card Reader. Supports the SATEL made proximity card readers to enable performance of the access control functions and operation of the electromagnetic door lock.

CA-64 DR. Expander of "DALLAS" Chip Readers. Supports the DALLAS chip readers to enable performance of the access control functions and operation of the electromagnetic door lock.

CA-64 E Zone Expander. Enables the system expansion by 8 zones. The expander with electronics in version 2.1 (or later) and firmware in version 2.0 (or later), where the DIP-switch 8 is set in ON position, will be identified by the control panel as CA-64 Ei. Roller shutter motion detectors (rope detectors) and vibration detectors (2 additional line types) can be connected to the CA-64 Ei expander zones.

CA-64 EPS Zone Expander with Power Supply. Enables the system expansion by 8 zones. Equipped with a 2.2 A built-in switching mode power supply. The expander with electronics in version 2.1 (or later) and firmware in version 2.0 (or later), where the DIP-switch 8 is set in ON position, will be identified by the control panel as CA-64 Ei. Roller shutter motion detectors (rope detectors) and vibration detectors (2 additional line types) can be connected to the CA-64 Ei expander zones.

CA-64 ADR Addressable Zone Expander. Enables the system expansion by 48 zones. Equipped with a 2.2 A built-in switching mode power supply. The INTEGRA control panels support the addressable zone expanders having firmware in version v1.5 or later.

CA-64 O-OC/CA-64 O-R/CA-64 O-ROC. Output Expander. Enables expansion of the system by 8 outputs. Made in three versions: 8 OC type outputs, 8 relay outputs and 4 relay outputs/4 OC outputs.

INT-ORS. DIN-rail outputs expander. Enables the system to be expanded by 8 relay outputs. The relays can control the electrical devices supplied with 230 V AC voltage.

Note: *If the sixth DIP-switch in the INT-ORS expander is set in the upper position, the device will be identified by the control panel as the CA-64 O outputs expander.*

CA-64 OPS-OC/CA-64 OPS-R/CA-64 OPS-ROC. Output Expander with Power Supply. Enables expansion of the system by 8 outputs. Made in three versions: 8 OC type

outputs, 8 relay outputs and 4 relay outputs/4 OC outputs. Equipped with a 2.2 A built-in switching mode power supply.

INT-IORS. DIN-rail zones/outputs expander. Enables the system to be expanded by 8 zones and 8 relay outputs. The relays can control the electrical devices supplied with 230 V AC voltage.

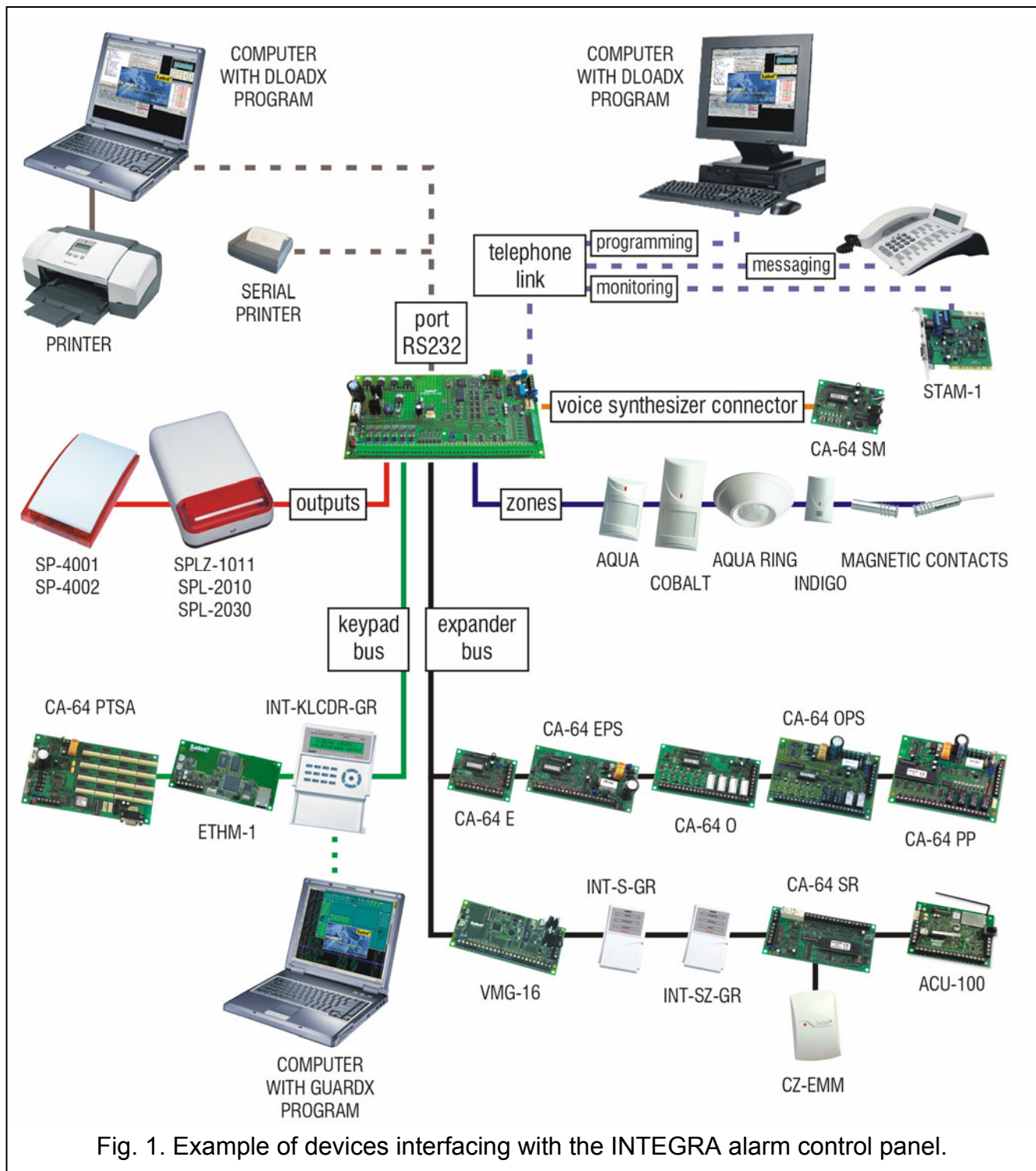

Fig. 1. Example of devices interfacing with the INTEGRA alarm control panel.

Note: If the sixth DIP-switch in the INT-IORS expander is set in the upper position, the device will be identified by the control panel as the CA-64 PP zone/output expander.

CA-64 PP Zone/Output Expander with Power Supply. Enables expansion of the system by 8 zones and 8 outputs (4 relay and 4 OC type). Equipped with a 2.2 A built-in switching mode power supply.

CA-64 SM Voice Synthesizer Expander. Capable of storing 16 voice messages, each with 15 second duration. The messages are used for alarm notification via telephone.

VMG-16 Voice Message Generator. Plays back prerecorded messages when specified events occur in the system.

ACU-100 Controller of ABAX Wireless System. Enables expansion of the system by adding wireless devices.

INT-RX. 433 MHz remote key fob operation expander. Makes it possible to assign a system of remote key fobs to the users so that by using them the users can control the system.

4. System installation



All electric connections may only be made with power supply disconnected.

The following tools will be useful during installation:

- blade screwdriver 2.5 mm,
- Phillips screwdriver,
- precision pliers,
- flat nose pliers,
- drill with a set of drill bits.

4.1 Installation plan

Installation must be preceded by preparation of a plan of the security alarm system. It is advisable that you draw up a sketch of the premises, showing all the devices to be included in the system, i.e. the control panel, keypads, detectors, sirens, expansion modules, etc. The control panel and other security system components should be installed within the boundaries of the protected area.

4.2 Estimation of system current consumption

At the stage of planning the security system, you should sum up the currents consumed by all devices included in the system (control panel mainboard, keypads, additional modules, detectors, sirens, etc.). The calculation should also take into account the battery charging current. If the sum of currents exceeds the control panel capacity, expanders with power supply or an extra power supply unit must be used in the system.

The sum of currents consumed by the devices connected to the power supply unit (expander with power supply) must not exceed the power supply output current.

When planning connection of devices to particular power outputs (control panel, expander with power supply, etc.), remember that the sum of currents consumed by these devices must not exceed the maximum current-carrying capacity of those outputs.

4.3 Cabling

It is recommended that straight unscreened cable be used for making electric connections between devices included in the system (using the twisted pair type of cable, e.g. UTP, STP, FTP is not advisable).

Cross-section of the power supply wires should be selected so that the supply voltage drop between the power supply and the supplied device should not exceed 1 V as against the output voltage.

In order to guarantee correct functioning of the system components it is important to ensure that resistance and capacitance of the signal wires are as low as possible. When the distance between the devices is more substantial, several wires connected in parallel may have to be used for each signal, in order to reduce conductor resistance. This, however, may lead to an increase of conductor capacitance. Too high resistance or capacitance of the cables connecting the control panel to keypads or expansion modules can prevent the devices from working correctly (e.g. the control panel will be unable to identify devices, absence of devices will be reported, etc.). When selecting the length of cables, follow recommendations set out in sections on connection of particular types of devices.

The signal wires of keypad bus (DTM, CKM, COM) must be run in one cable (they must not be run in separate cables). Also the signal wires of expander bus (DT, CK, COM) must be run in one cable.

When you make the cabling, remember that there must be sufficient distance between the low-current wires and the 230 V AC power supply wires. Avoid running the signal cables in parallel of the 230 V AC supply cables in close vicinity of them.

4.4 Installation of control panel mainboard



The control panel mainboard contains electronic components sensitive to electric charges.

Before connecting the mainboard to power supply source (battery, alternating voltage from transformer), you must have finished all the installation work with regard to hardwired devices (connection of keypads, expansion modules, detectors, sirens, etc.).

The control panel should be installed indoors, in spaces with normal humidity of air. The control panel must be protected against unauthorized access.

A permanent (not disconnectable) 230 V AC power supply circuit with protective grounding must be available at the control panel installation place.

Terminals:

AC	- power supply inputs (18 V AC)
COM	- common ground
OUTn	- programmable outputs (n=output number):
	high-current: OUT1 and OUT2 in the INTEGRA24 and INTEGRA 32 control panels; from OUT1 to OUT4 in the INTEGRA 64 and INTEGRA 128 control panels
	low-current: OUT3 and OUT4 in the INTEGRA24 control panel; from OUT3 to OUT8 in the INTEGRA 32 control panel; from OUT5 to OUT16 in the INTEGRA 64 and INTEGRA 128 control panels

Note: *If the high-current outputs are not used, they should be loaded with 2.2 kΩ resistors.*

+KPD	- dedicated power supply output for devices connected to keypad bus (13,6...13,8 V DC)
DTM	- keypad bus data
CKM	- keypad bus clock
+EX / +EX1 / +EX2	- dedicated power supply output for devices connected to expander bus (13,6...13,8 V DC)
DT / DT1 / DT2	- expander bus data

- CK / CK1 / CK2** - expander bus clock
- AUX** - power supply output (13,6...13,8 V DC)
- Zn** - zones (n=zone number)
-  - protective terminal of telephone communicator (connect to protective circuit only)
- T-1, R-1** - extension telephone line (telephone set connection)
- TIP, RING** - public telephone line (analog)

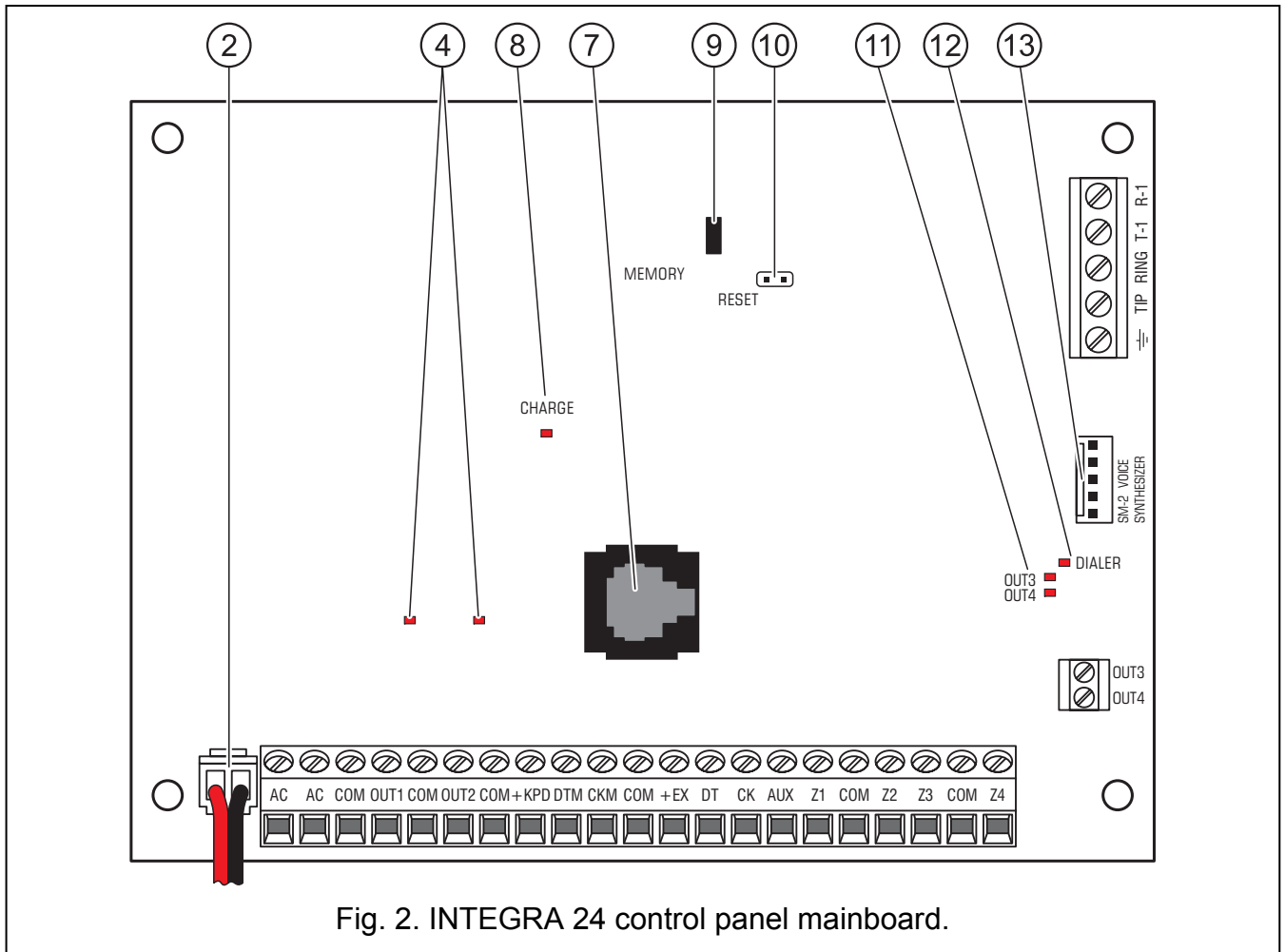

Fig. 2. INTEGRA 24 control panel mainboard.

Explanations for Figures 2, 3 and 4:

- 1 - **fuse for battery charging circuit.**
- 2 - **battery connection cables** (red +, black -).
- 3 - **pins for setting battery charging current:**
 - pins shorted (jumper on) – 400 mA (INTEGRA 32) or 500 mA (INTEGRA 64, INTEGRA 128)
 - pins open (no jumper) – 800 mA (INTEGRA 32) or 1000 mA (INTEGRA 64, INTEGRA 128)
- 4 - **LEDs indicator of high-current outputs status.**
- 5 - **LED indicator of +KPD power supply output status.**
- 6 - **LED indicator of +EX1 and +EX2 power supply outputs status.**

- 7 - **port RS-232.** It allows local programming and management of the system by means of DLOADX or GUARDX program (the cable for making connection RJ type socket on the control panel mainboard and the DB9 socket on the computer is supplied by SATEL). Enables remote programming by means of DLOADX program through TCP/IP network, if the ETHM-1 module is connected. Makes interfacing possible with an external analog, GSM or ISDN modem.
- 8 - **CHARGE LED.** Indicates battery charging.
- 9 - **MEMORY pins. Never remove jumper from these pins.** Removal of the jumper results in disconnection of the battery backup for the clock and RAM memory and, consequently, in loss of the clock settings and all data stored in the RAM memory.
- 10 - **RESET pins.** In case of emergency, they make it possible to start the STARTER program, local computer programming function or service mode (see PROGRAMMING manual).
- 11 - **LEDs.** Indicate status of low-current outputs.
- 12 - **DIALER LED.** Indicates the status of control panel communicator.
- 13 - **sockets for voice synthesizer.**

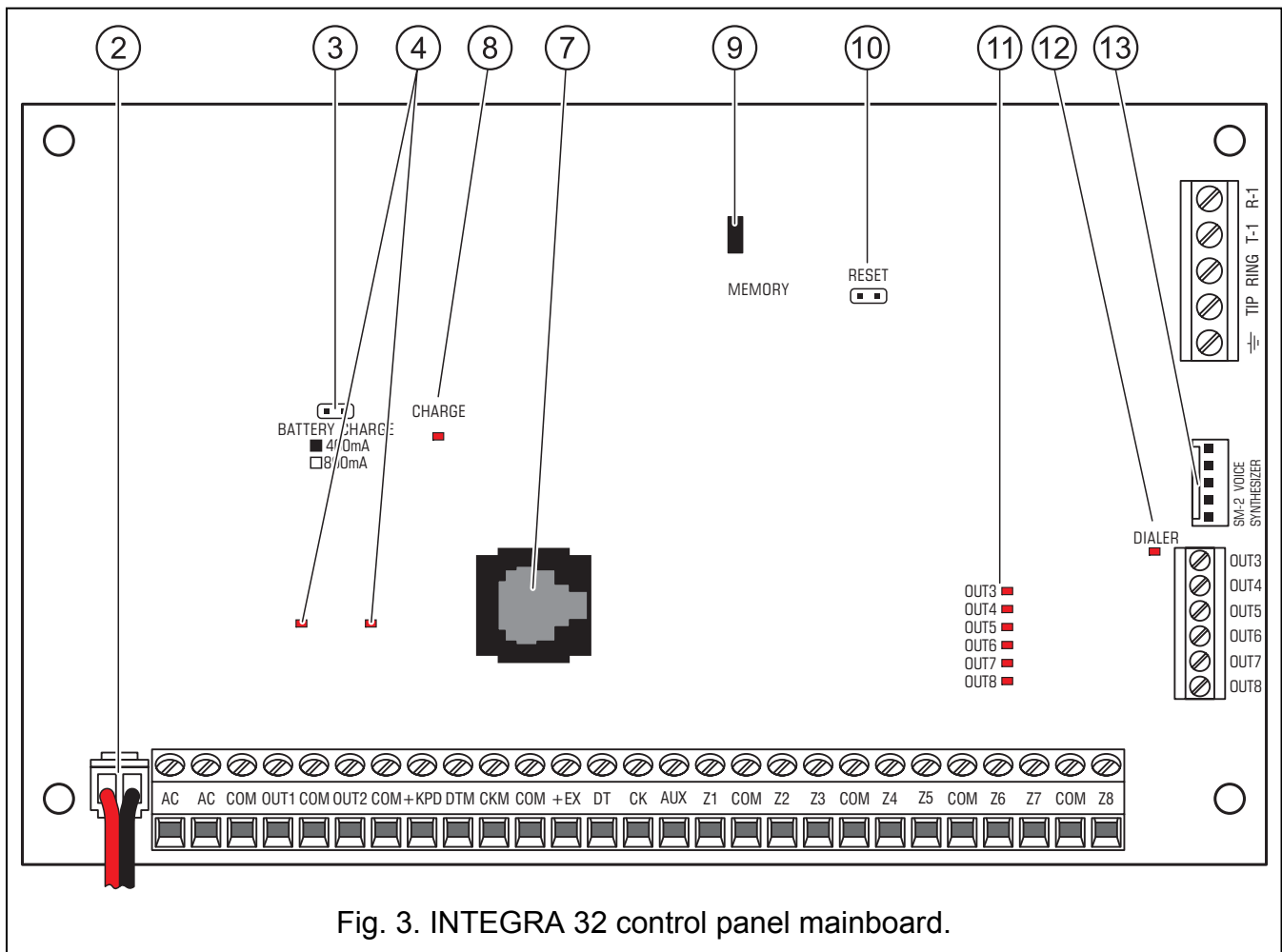

Fig. 3. INTEGRA 32 control panel mainboard.

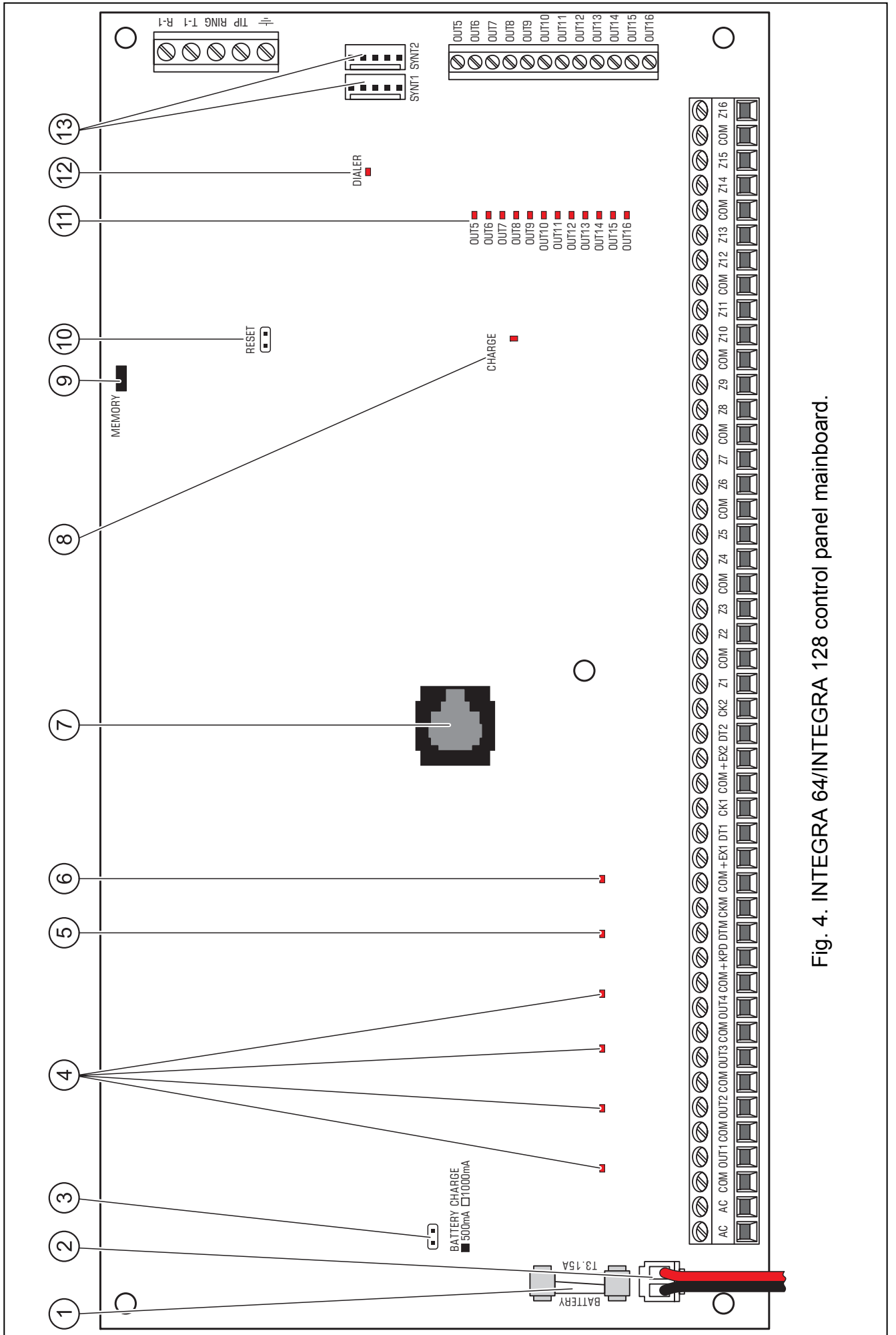

Fig. 4. INTEGRA 64/INTEGRA 128 control panel mainboard.

4.5 Connecting LCD keypads and other devices to keypad bus

Depending on the selected control panel, from 4 to 8 different keypads or other devices to be connected to keypad bus can be installed in the system. They are connected in parallel. The data are addressable and all devices function independently.

The keypad bus terminals on control panel mainboard have designations COM, +KPD, DTM and CKM. The +KPD output enables powering of the keypad bus devices (the output has a polymer fuse).

The distance between the keypad or other device to be connected to keypad bus and the control panel may be up to **300 m**. Table 1 shows the number of wires required for correct connection of devices to the keypad bus, if using a 0.5 mm² cross-section straight-through cable.

	+KPD	COM	CKM	DTM
Distance	Number of wires			
up to 100 m	1	1	1	1
100-200 m	2	2	1	1
200-300 m	4	4	2	2

Table 1.

Notes:

- The signal wires (CKM, DTM and COM) must be run in one cable!
- Supply voltage measured at the LCD keypad terminal block, with the backlighting on, must not be lower than 11 V.
- Devices installed far from the control panel may be supplied locally from an independent power source.

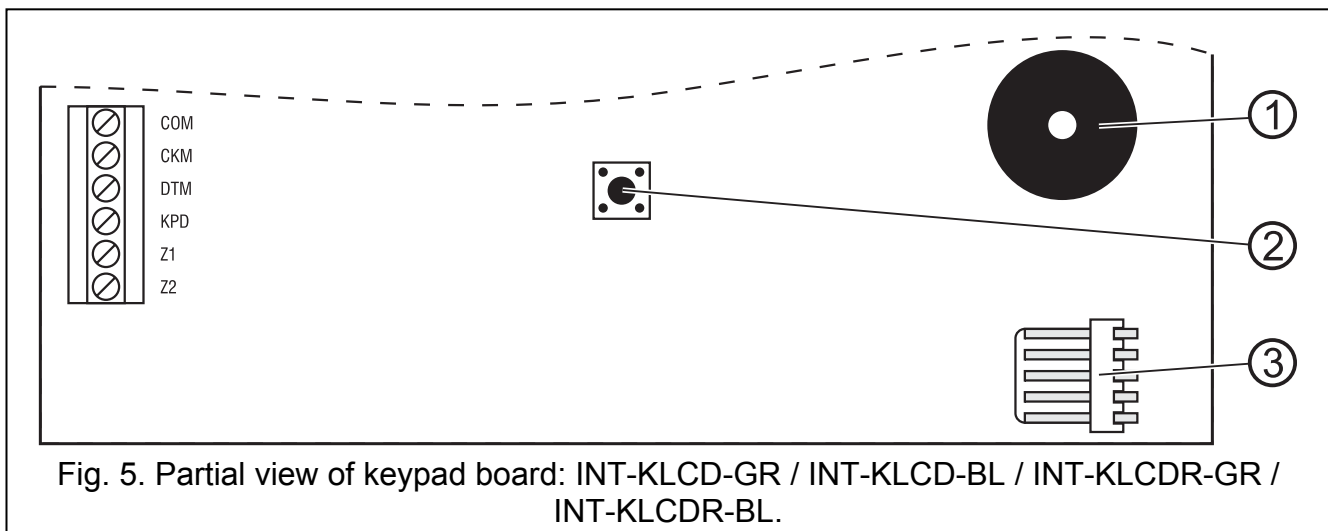

Fig. 5. Partial view of keypad board: INT-KLCD-GR / INT-KLCD-BL / INT-KLCDR-GR / INT-KLCDR-BL.

Explanations to Figures 5, 6 and 7:

- 1 – buzzer
- 2 – tamper contact
- 3 – RS-232 port

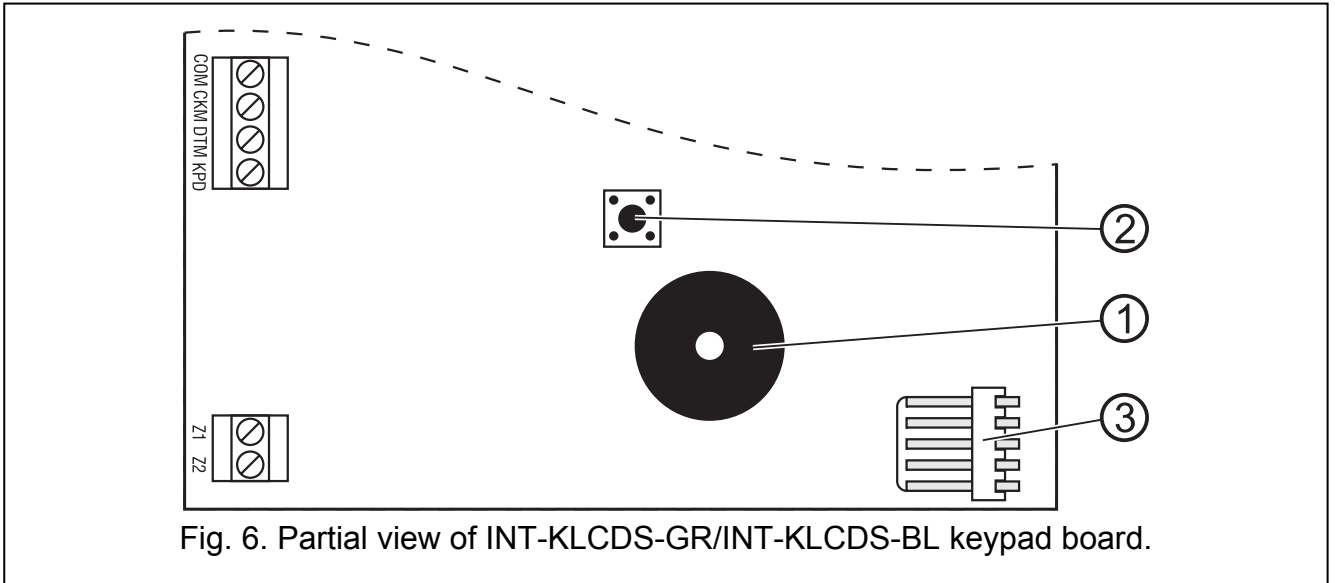

Fig. 6. Partial view of INT-KLCDS-GR/INT-KLCDS-BL keypad board.

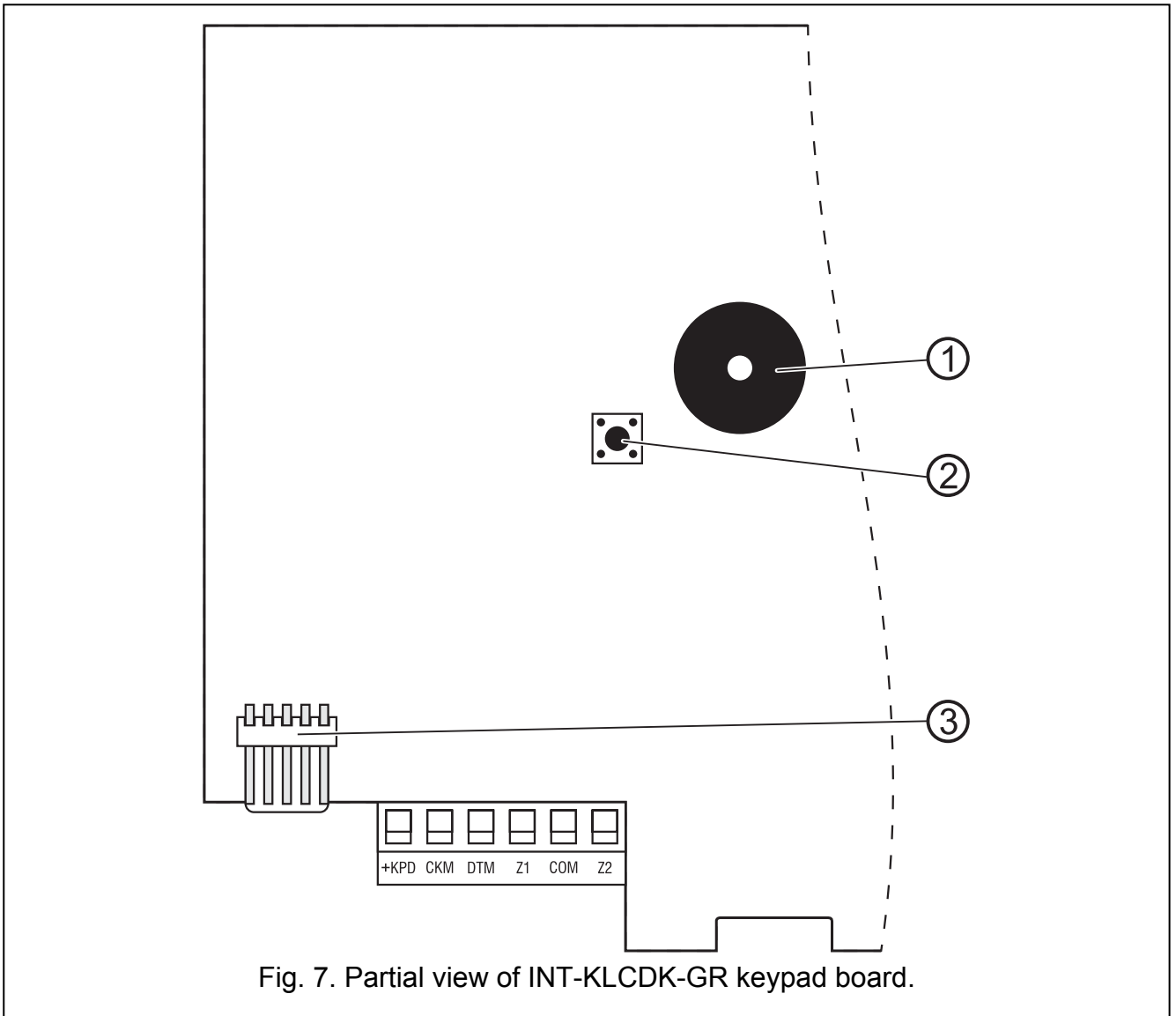

Fig. 7. Partial view of INT-KLCDK-GR keypad board.

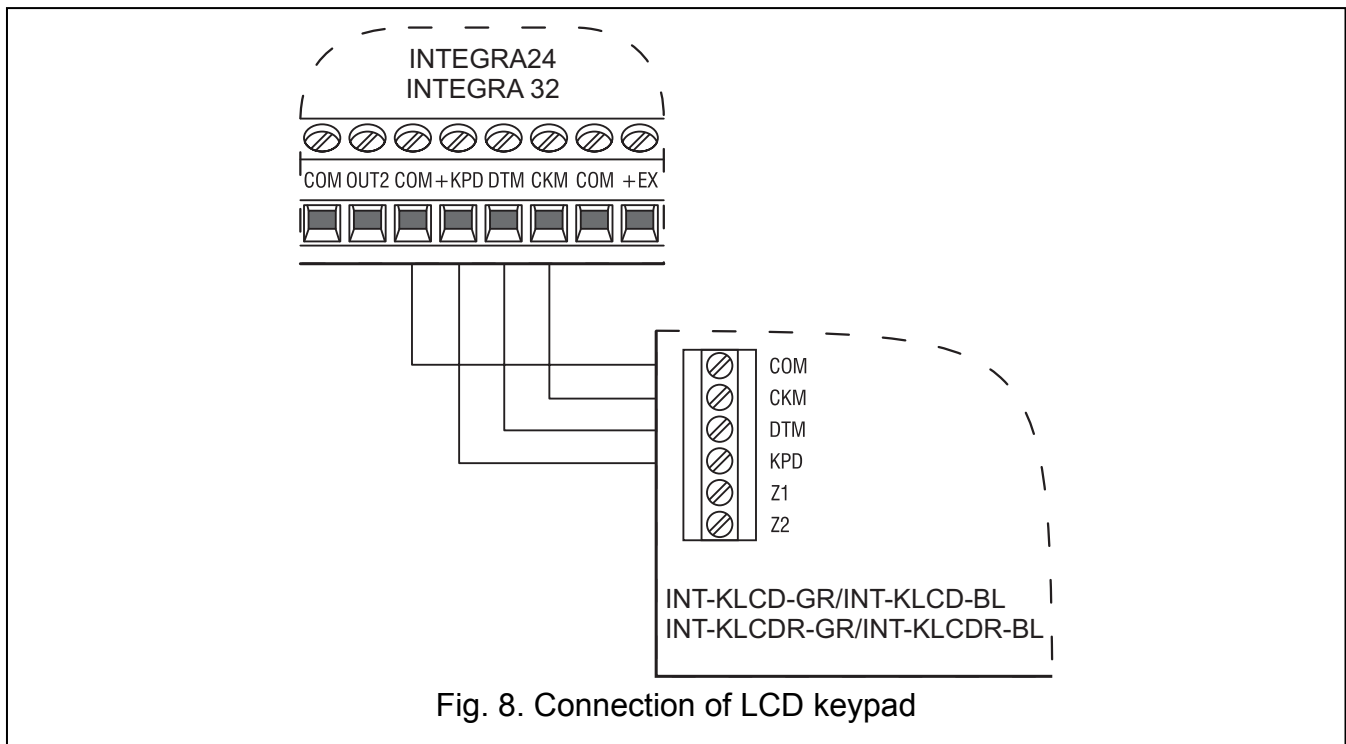

Fig. 8. Connection of LCD keypad

4.5.1 Addressing devices connected to keypad bus

Each keypad/device to be connected to keypad bus must have its own individual address from the 0 to 3 range (INTEGRA 24 and INTEGRA 32 control panels) or from the 0 to 7 range (INTEGRA 64 and INTEGRA 128 control panels). Addresses must not repeat. It is recommended that consecutive addresses be assigned starting from 0.

In LCD keypads, the address is set by software means and saved to the EEPROM non-volatile memory. By default, address 0 is set in all keypads. This address can be changed in two ways:

- by means of service function,
- without entering the service mode.

The address in other devices is set by means of DIP-switches.

When started with default (factory) settings, the alarm control panel will support all keypads connected to the bus, irrespective of what addresses are set in them. Thus it is possible to set correct individual addresses in the keypads and perform identification of all devices connected to the bus. Execution of the service function LCD KEYPADS IDENTIFICATION (SERVICE MODE → STRUCTURE → HARDWARE → IDENTIFICATION → LCD KEYPADS ID.) is necessary for correct support of the keypads and other devices connected to the bus. The system control is only possible after execution of the identification function. The function checks the addresses at which keypads or other devices are connected and registers them in the system. Disconnection of a keypad /device registered in the system will trigger tamper alarm. Any commands from an unregistered LCD keypad are rejected by the control panel (and the "Keypad is not serviced" message appears on the display").

Notes:

- *Each change of the LCD keypad (or other device connected to the keypad bus) address requires execution of the keypad identification function.*
- *Setting the same address in several keypads will trigger tamper alarm, display the message "This keypad is changed", and disable operation of such keypads. To restore the operation of keypads, change their repeated addresses into unique ones.*

4.5.1.1 Programming keypad address by means of service function

1. By means of any supported keypad, enter the control panel service mode ([SERVICE CODE][*] →SERVICE MODE).
2. Start the function KEYPADS ADDR. (→STRUCTURE →HARDWARE →IDENTIFICATION →KEYPADS ADDR.).
3. The message shown in Figure 9 will appear on display of all keypads connected to the control panel.

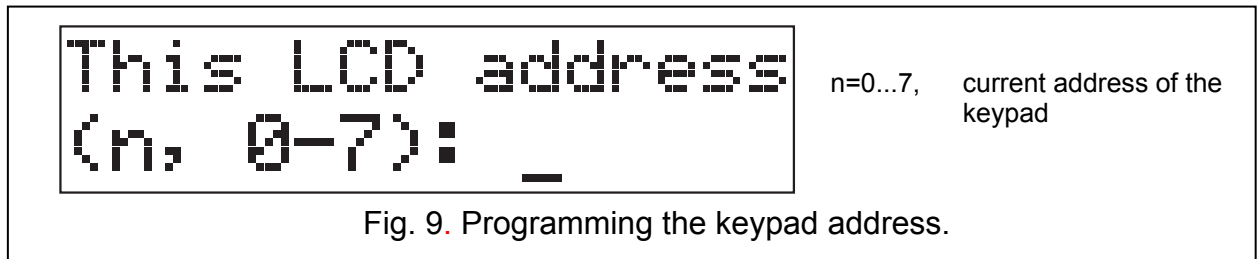

4. Enter a proper address in the selected keypad(s). The address change will be confirmed by four short and one long beeps.
5. To terminate the address change function, press the [*] key. The function will be terminated automatically after 2 minutes from being started. Termination of the function is equivalent to quitting the service mode and restarting the keypad.

4.5.1.2 Programming keypad address without entering service mode

This method of address programming is particularly useful when – due to repeating addresses – the keypad support has been disabled and entering the service mode is impossible.

1. Disconnect keypad power supply (KPD) and signal wires CKM and DTM.
2. Short the keypad terminals CKM and DTM.
3. Switch on keypad power supply.
4. The text shown in fig. 9 will appear on the display.
5. Enter a new address. The keypad will confirm execution of the function by four short and one long beeps. If it is necessary to change the entered address, press the [*] key (keypad restart will follow and the text shown in fig. 9 will again be displayed).
6. Disconnect the keypad power supply.
7. Open the keypad terminals CKM and DTM.
8. Connect the keypad correctly to the control panel.

4.5.2 Numeration of keypad zones

Keypad address	Numbers of Z1, Z2 zones in security system							
	INTEGRA 24		INTEGRA 32		INTEGRA 64		INTEGRA 128	
	Z1	Z2	Z1	Z2	Z1	Z2	Z1	Z2
0	5	6	25	26	49	50	113	114
1	7	8	27	28	51	52	115	116
2	21	22	29	30	53	54	117	118
3	23	24	31	32	55	56	119	120
4					57	58	121	122
5					59	60	123	124
6					61	62	125	126
7					63	64	127	128

Table 2.

The address set in the keypad defines which numbers in the system will be assigned to the keypad zones (see table 2). You can define for each LCD keypad whether or not its zones will be used in the system. If the zone numbers of LCD keypad and expander coincide, the keypad zones have priority (in such a case, the corresponding expander zones will not be supported).

4.5.3 Keypad RS-232 port

The keypad RS-232 port makes it possible to connect the computer with GUARDX program installed. The GUARDX program enables visualization of the protected facility on computer monitor, operation of the system from an independent on-screen LCD keypad, access to the event log, as well as creating and editing of the system users.

Connection to the computer is permanent, made with the use of an ordinary unscreened cable. In case of straight-through cable with conductor cross-section 0.5 mm^2 (the use of twisted-pair wire is not recommended), the distance between the computer and the keypad can be up to **10 meters**. The method of making connection is shown in Fig. 10.

Note: Activate the "RS communication" option in parameters of keypads to which the user's computer is to be connected. Data exchange with the computer begins automatically when the GUARDX program is started.

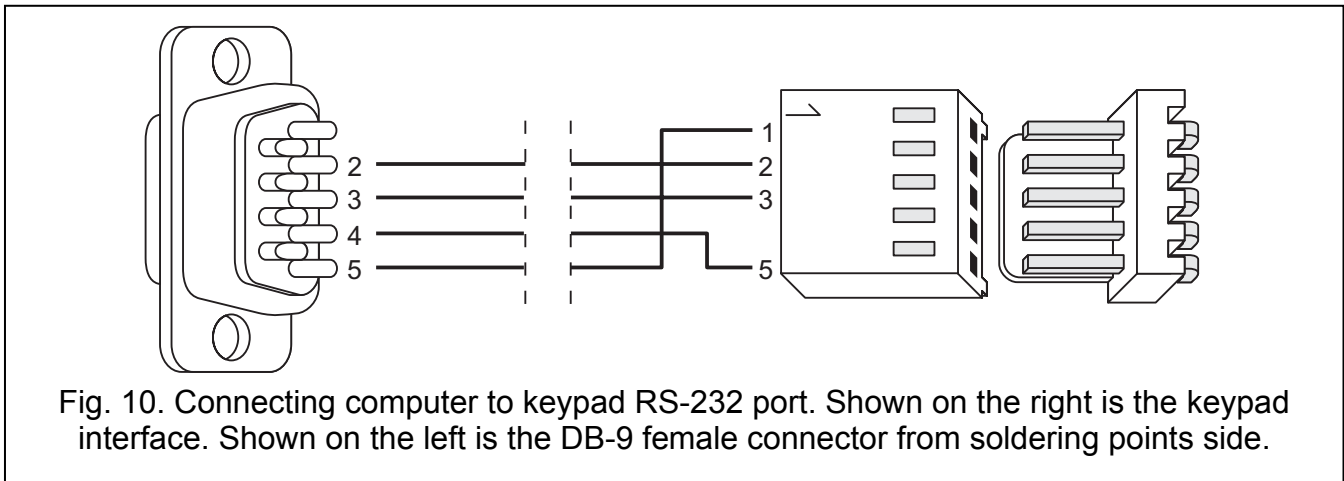

4.6 Connecting devices to expander bus

The INTEGRA control panels are provided with one or two buses designed for connecting the expansion modules (expanders). Both buses in the INTEGRA 64 and INTEGRA 128 control panels have the same priority and can be used in parallel (it is irrelevant which modules are connected to each bus). All modules are connected in parallel, and up to 32 modules may be connected to each bus.

Depending on the control panel and the number of expander bus, the mainboard terminals are designated as follows:

- COM, +EX, DT, CK (INTEGRA 24 and INTEGRA 32);
- COM, +EX1, DT1, CK1 (INTEGRA 64 and INTEGRA 128, first bus);
- COM, +EX2, DT2, CK2 (INTEGRA 64 and INTEGRA 128, second bus).

The +EX/+EX1/+EX2 outputs enable powering of the expander bus devices (the outputs are provided with polymer fuse).

The total length of the expander bus may not exceed **1000 m**. Table 3 shows the number of wires required for correct connection of devices to the expander bus, if using a 0.5 mm^2 cross-section straight-through cable.

distance between module and control panel	number of wires in signal cable		
	CK / CK1 / CK2	DT / DT1 / DT2	COM
up to 300 m	1	1	1
300 – 600 m	2	2	2
600 – 1000 m	2	2	4

Table 3.

Note: Signal wires (DT, CK and COM) must be run in one cable!

The modules without power supply unit may be powered directly from the control panel if the distance between control panel and module is not higher than 300 m. Where distances are small (up to 100 m), the modules without power supply unit may be connected one after the other to one supply cable (see Fig. 13). If this is the case, devices connected to the expanders must be independently supplied (by means of a separate cable from the control panel, expander with power supply, or a power supply unit). Where the distance between the control panel and the modules exceeds 300 m, the modules without power supply unit should not be supplied from the control panel. They should have an independent supply source (a power supply unit or an expander with power supply).

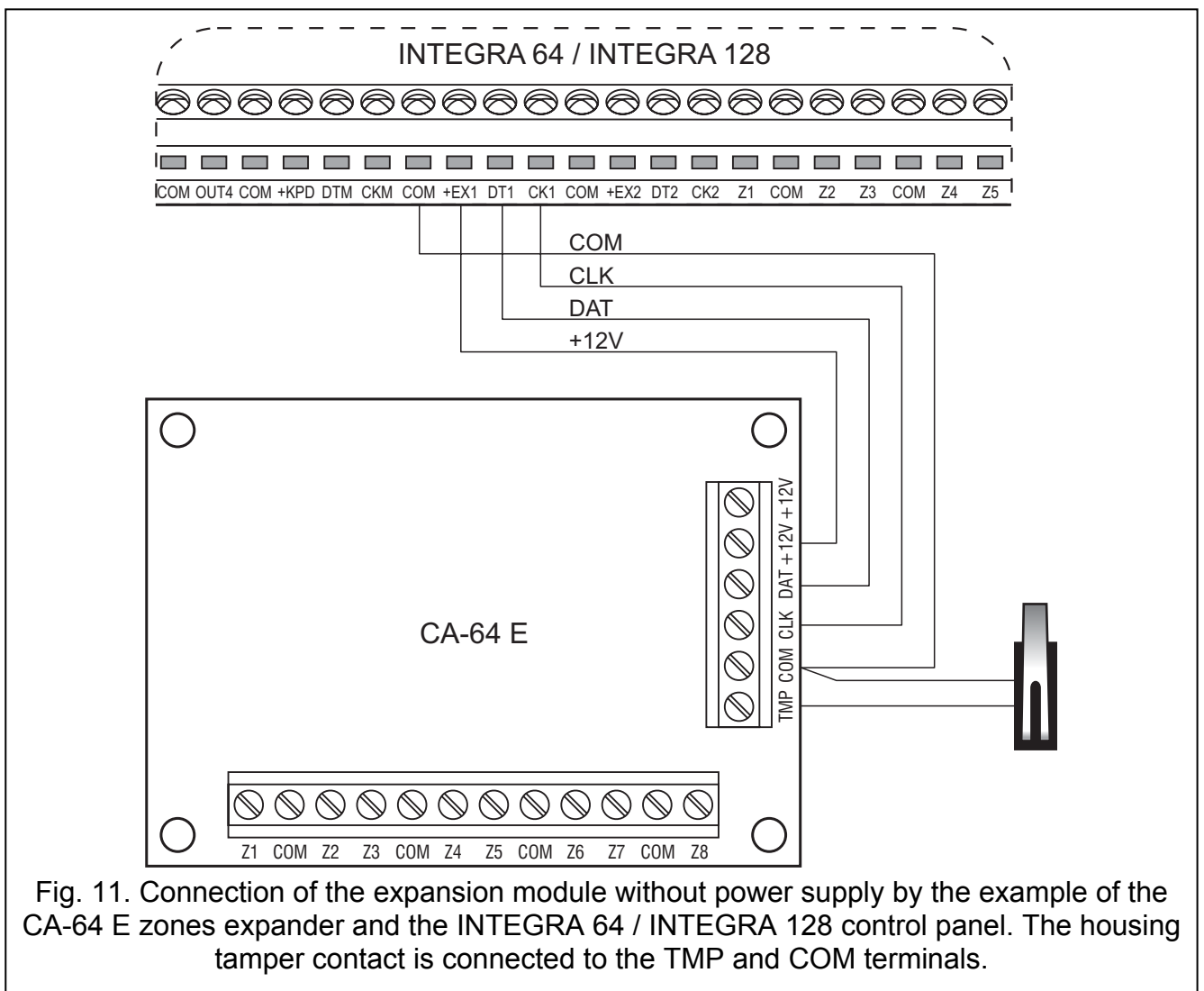

Fig. 11. Connection of the expansion module without power supply by the example of the CA-64 E zones expander and the INTEGRA 64 / INTEGRA 128 control panel. The housing tamper contact is connected to the TMP and COM terminals.

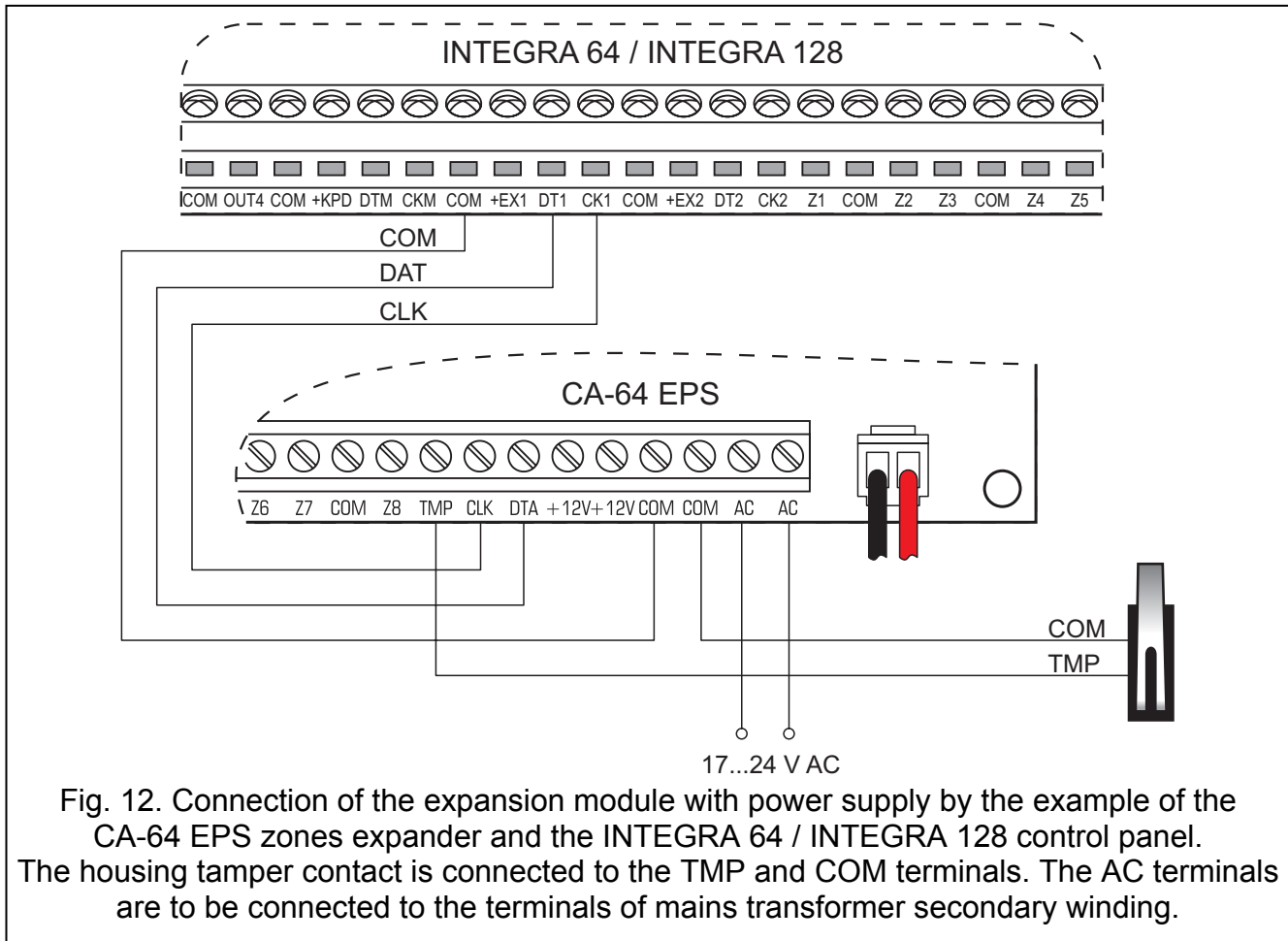

Fig. 12. Connection of the expansion module with power supply by the example of the CA-64 EPS zones expander and the INTEGRA 64 / INTEGRA 128 control panel. The housing tamper contact is connected to the TMP and COM terminals. The AC terminals are to be connected to the terminals of mains transformer secondary winding.

4.6.1 Addressing devices connected to expander bus

Each module to be connected to the expander bus must have its own individual address from the 0 to 31 range (the addresses must not repeat). It is recommended that consecutive addresses be assigned starting from 0. This will allow you to avoid problems during expansion of the system (e.g. changing numeration of zones or outputs due to connection of a new expander). The address is set by means of DIP-switches on keypad electronics boards. The expander addresses are displayed in the keypad in hexadecimal format. The addresses of modules connected to the first expander bus remain within the range from **00** to **1F**, and those of modules connected to the second bus – within the range from **20** to **3F**.

The control panel only supports the modules which are registered in the system by means of the EXPANDER IDENTIFICATION service function (SERVICE MODE → STRUCTURE → HARDWARE → IDENTIFICATION → EXPANDERS ID.). The function saves to the module memory a special (16-bit) number, which is used for checking the module availability in the system. The number is stored in EEPROM non-volatile memory and can only be changed after restarting the expander identification function. Hence, it is impossible to substitute another module for the identified one (even if a correct address is set in it). Substitution of another module for the identified one will trigger alarm (module tamper – verification error). Each change of module or module address requires restarting the expander identification function.

Notes:

- The control panel does not handle the module unless the identification function is completed with the "Found xx exp. (yy new)" message.

- A wrong module connection can make the correct identification of modules impossible, which is signaled by the message: "Error! Two expanders have the same addr.!"
- Too high resistance of cables connecting the module to the control panel (large distance, too small number of wires for a single signal) may result in the module being not recognized by the identification function.

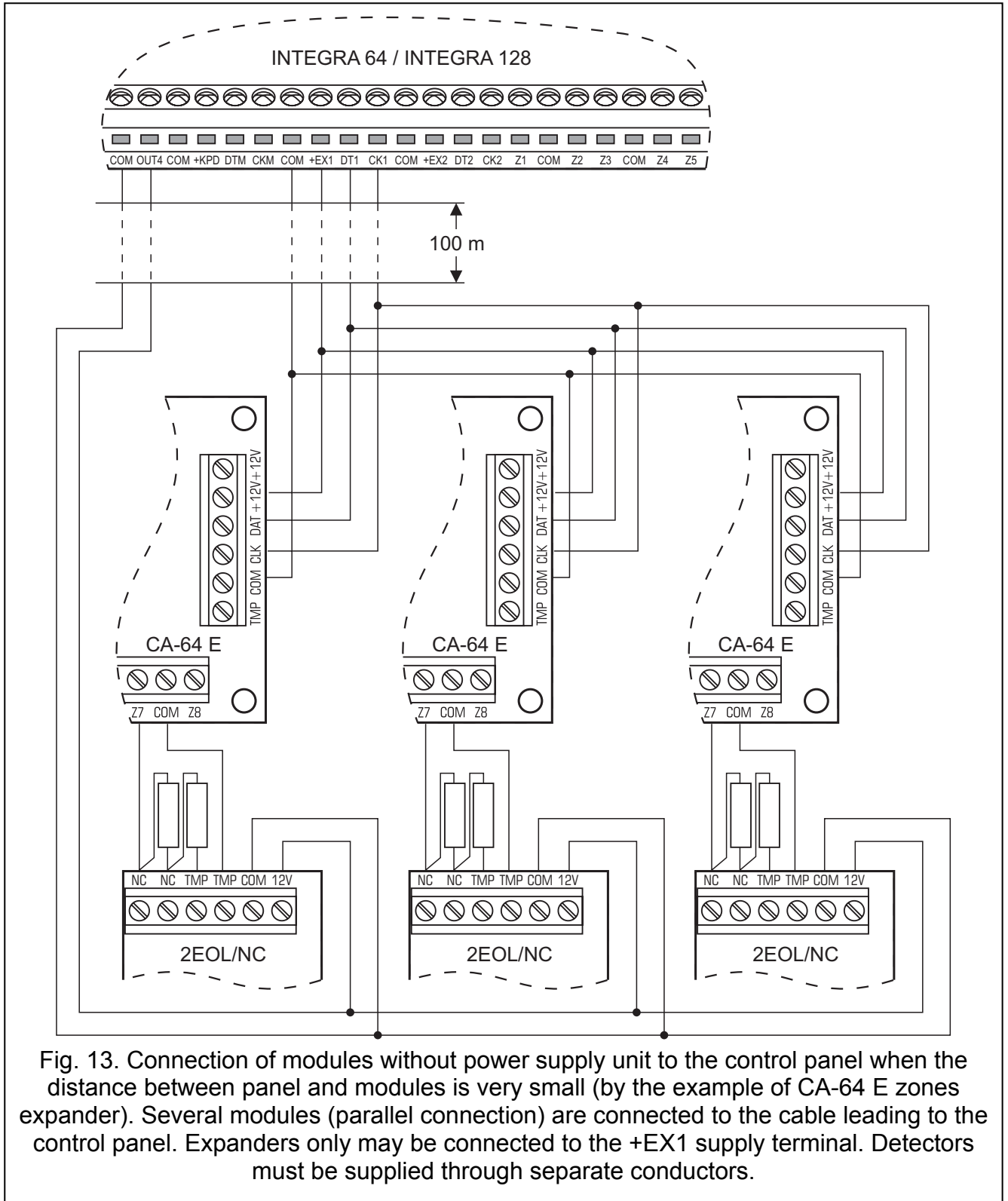
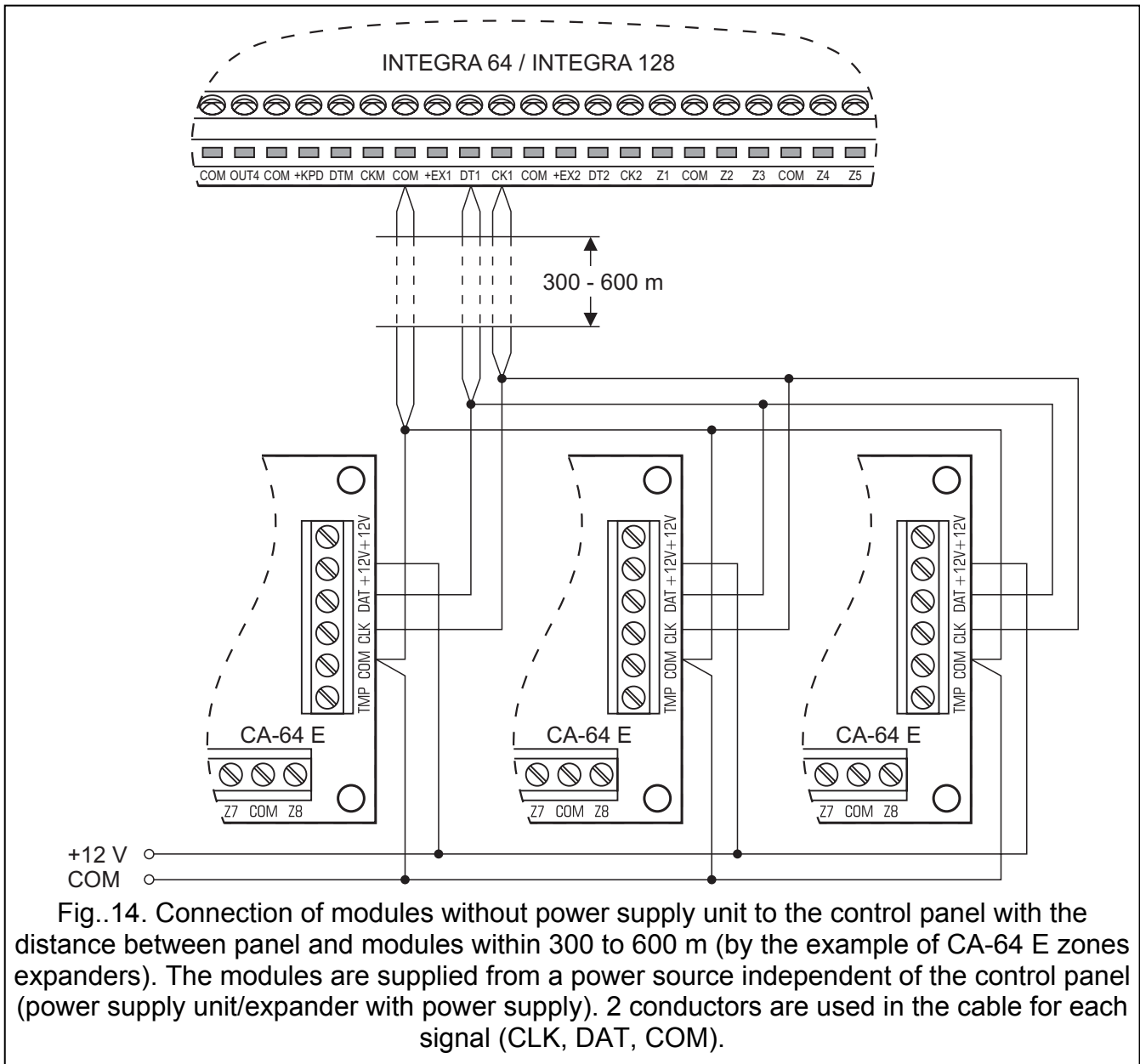

Fig. 13. Connection of modules without power supply unit to the control panel when the distance between panel and modules is very small (by the example of CA-64 E zones expander). Several modules (parallel connection) are connected to the cable leading to the control panel. Expanders only may be connected to the +EX1 supply terminal. Detectors must be supplied through separate conductors.



4.7 Connection of detectors

The INTEGRA can operate with any detectors. Each control panel zone and zones of LCD keypads and zone modules may operate in the following configurations:

- NC (normally closed),
- NO (normally open),
- EOL (end of line resistor),
- 2EOL/NO (NO type detector, double end of line resistor),
- 2EOL/NC (NC type detector, double end of line resistor).

In case of the CA-64 E expander (with electronics version 2.1 or later and program version 2.0 or later) and the CA-64 EPS expander (with electronics version 2.0 or later and program version 2.0 or later), the value of resistors used in EOL and 2EOL configurations is programmable. The resistor value for EOL configuration should be determined within the range from 500 Ω to 15 k Ω (for 2EOL configuration, the single resistor value is equal to half the defined value). To make the circuit in the alarm control panels, LCD keypads and other expanders (CA-64 ADR, INT-IORS, CA-64 PP) in EOL configuration, use the 2.2 k Ω resistor, and in 2EOL configuration – the 1.1 k Ω resistors.

The zones in the CA-64 E expander (with electronics version 2.1 or later and program version 2.0 or later) and in the CA-64 EPS expander (with electronics version 2.0 or later and program version 2.0 or later) may additionally work in the following configurations:

- roller (dedicated to connecting the roller shutter motion detectors (rope detectors)),
- vibration (normally closed, dedicated to connecting the vibration detector – an NC type of detector, e.g. magnetic contact, may be connected in series with the vibration detector).

All zones in the system can work in the configuration:

- follow output.

In case of this configuration, activating the output amounts to a zone violation (the output and the zone does not need to be physically connected). The zone does not need to exist physically, because virtual zones may be used as well. In case of the physically existing zones, programmed as the „follow output” ones, the physical violations and tampers of the zone are disregarded.

The AUX power supply output or any of the high-current outputs, programmed as POWER SUPPLY OUTPUT, can be used for powering detectors. In case of extended systems and large distances to the control panel, the detectors may be powered from expanders fitted with power supply units, or from additional power supply units. Information on powering detectors connected to expanders can be found in section CONNECTING DEVICES TO EXPANDER BUS.

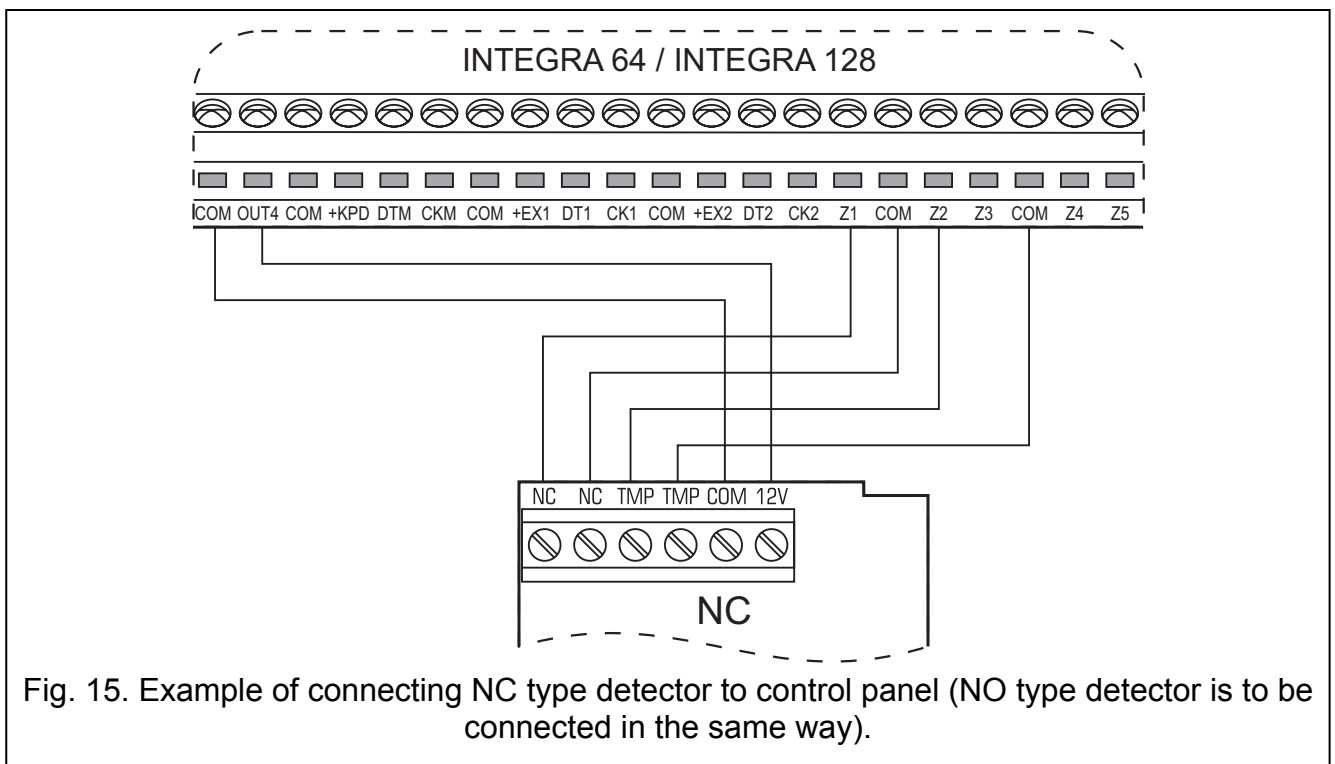

Fig. 15. Example of connecting NC type detector to control panel (NO type detector is to be connected in the same way).

Figures 15, 16, 17 and 18 show how the detectors are connected in various configurations. In the presented examples, the OUT4 output feeds the detectors (type 41 POWER SUPPLY). The detector signal is fed to the Z1 zone of the control panel. The Z2 zone, Figures 15, 16 and 17, has been programmed as type 9 (24H TAMPER). Separation of the grounds of detector power supply and signal informing of the status of detector connected to the control panel monitoring zone, eliminates the influence of the resistance of wires on the detector status detection. Assuming that only one detector is connected to the cable and the cable is not very long, the installation may be simplified by leading a common single wire for power supply ground (COM) and signal ground (COM).

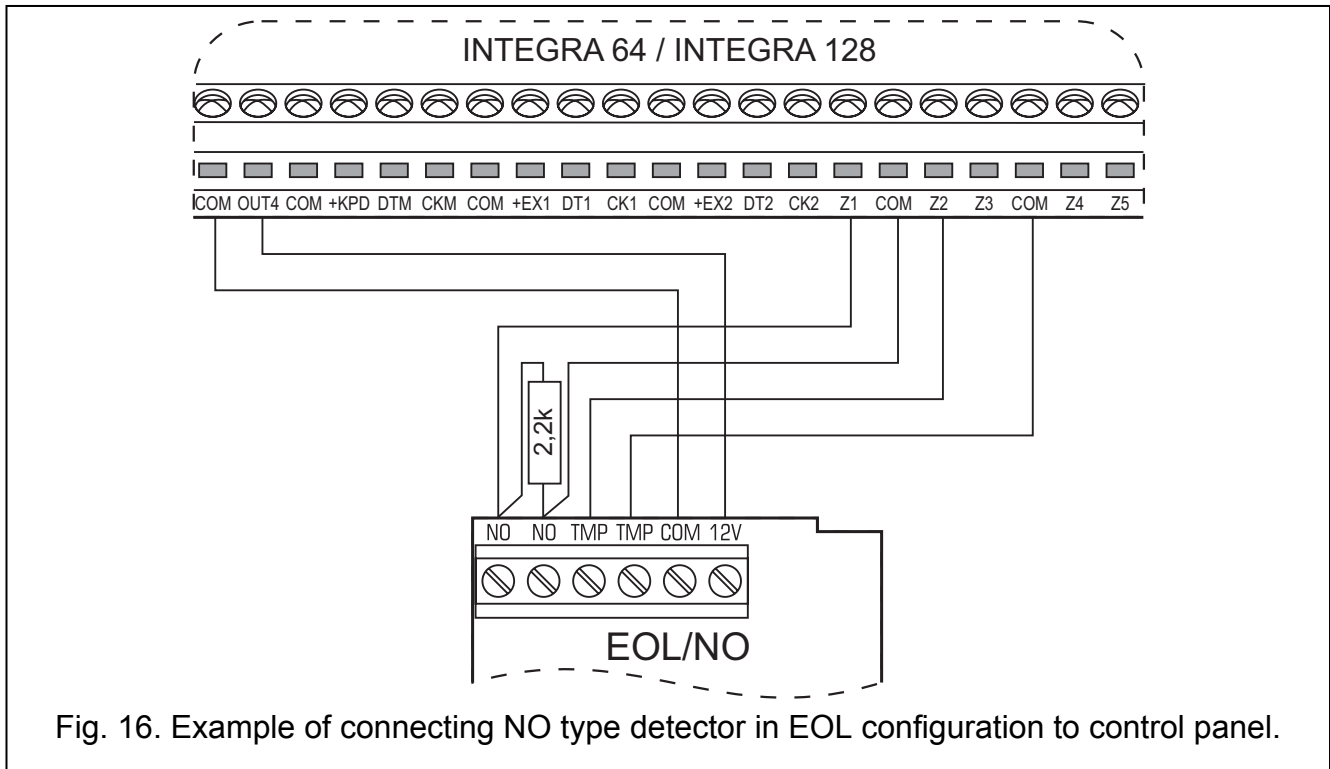

Fig. 16. Example of connecting NO type detector in EOL configuration to control panel.

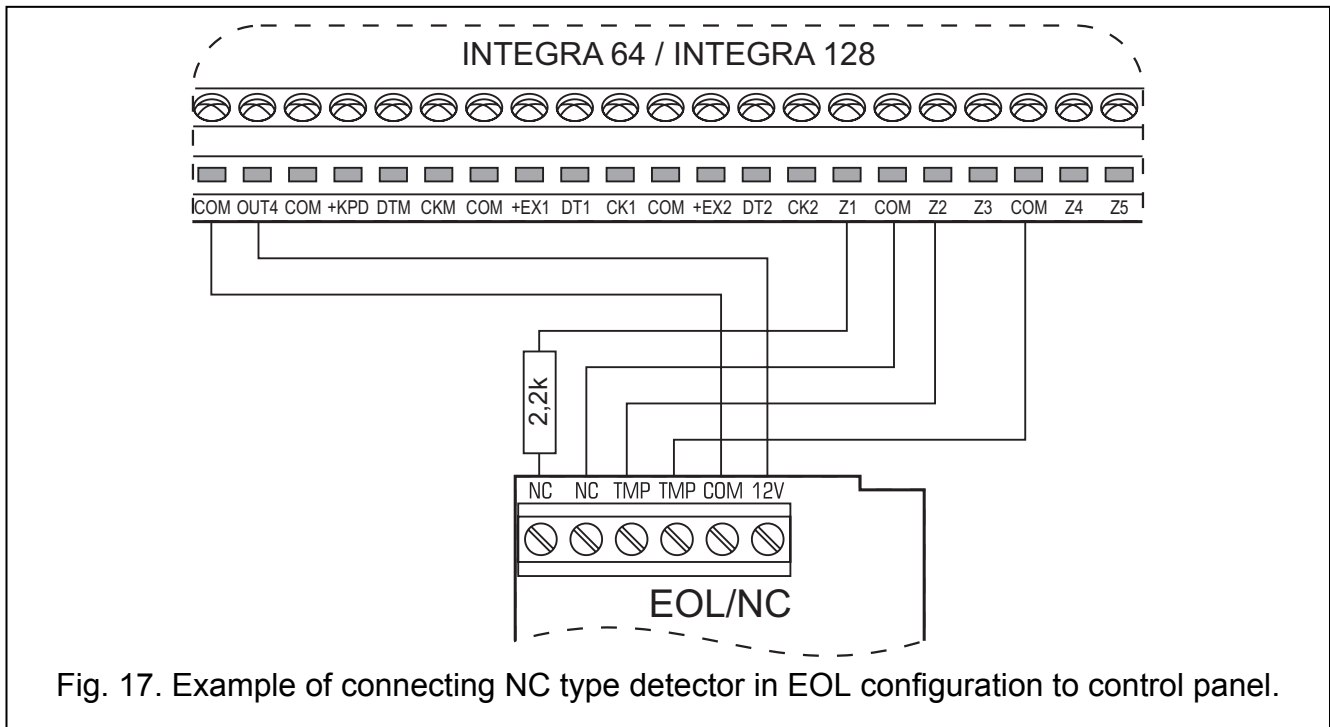
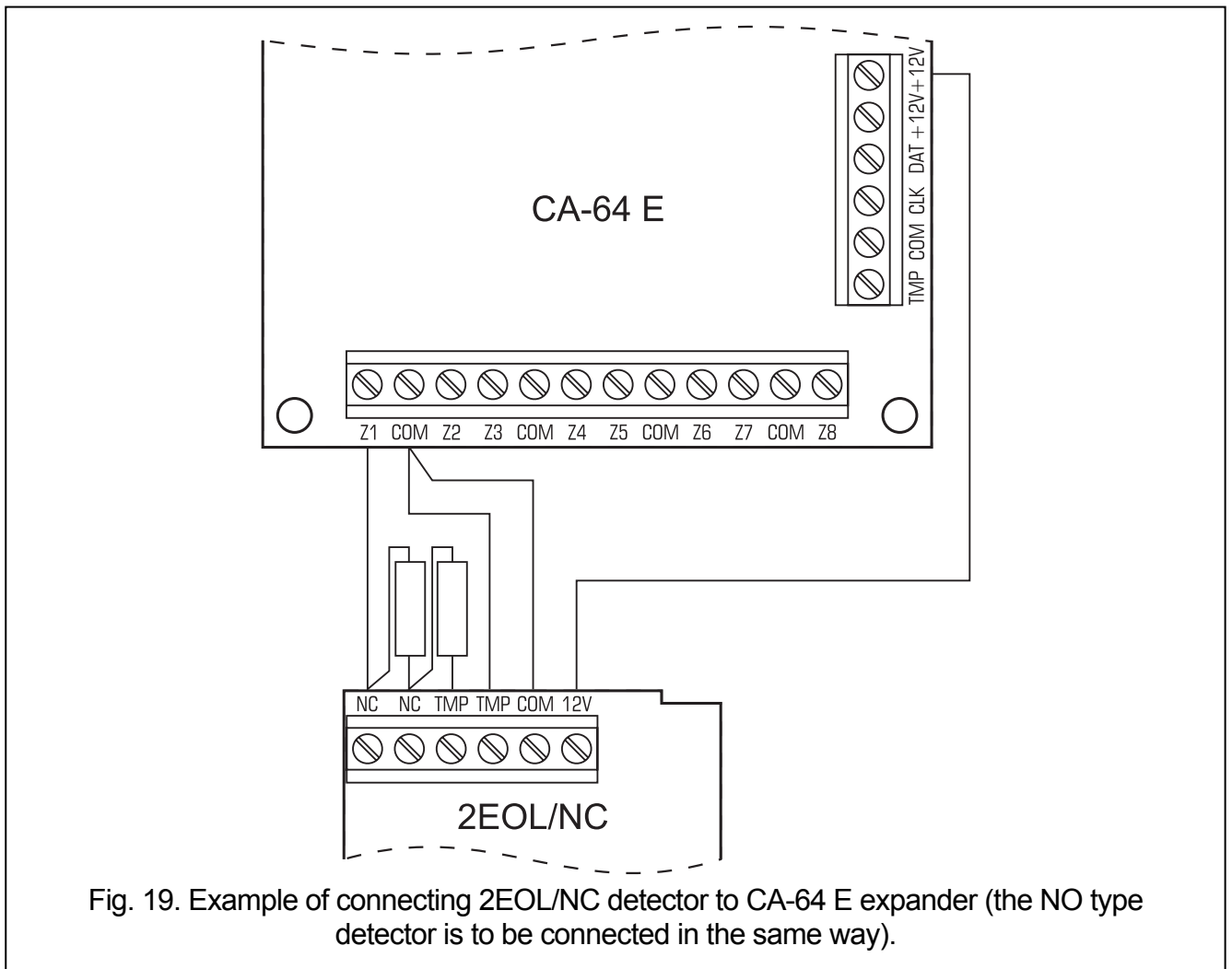
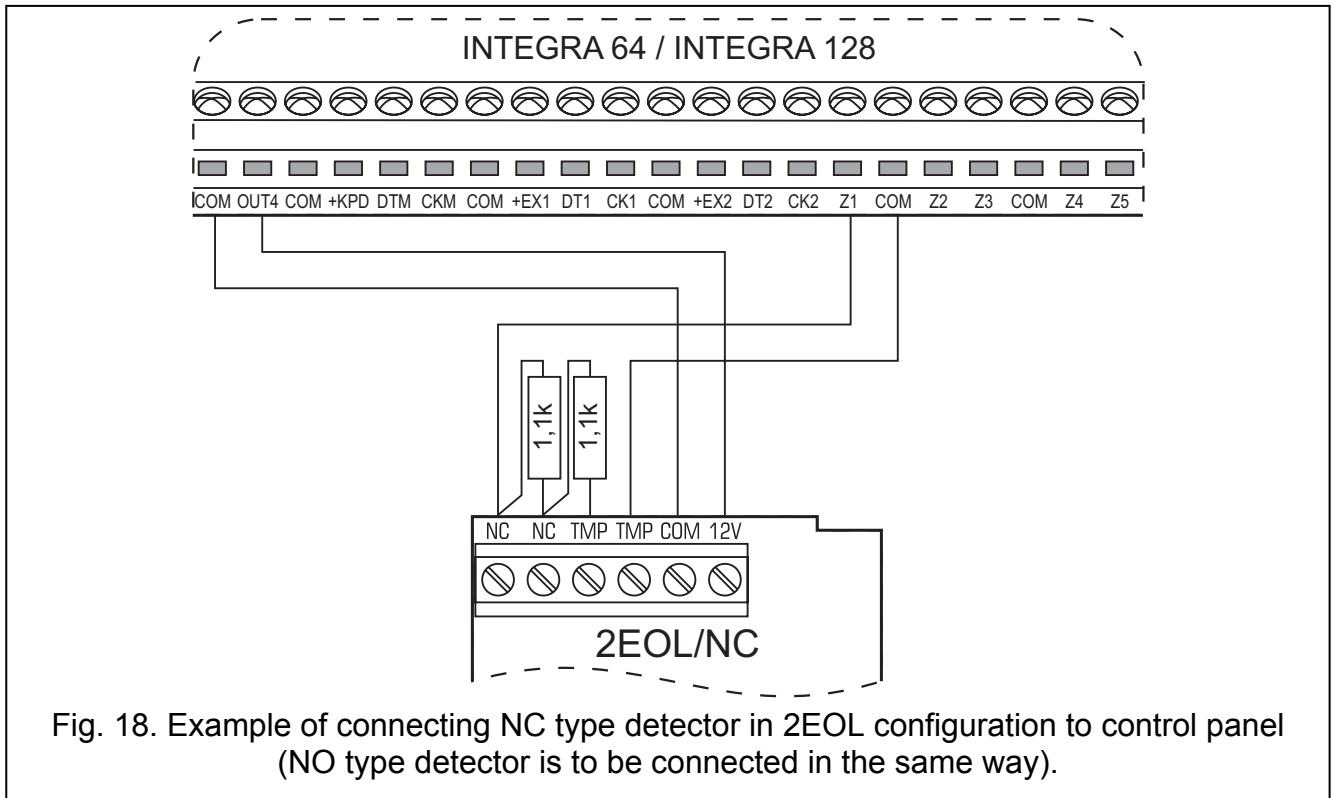

Fig. 17. Example of connecting NC type detector in EOL configuration to control panel.

The NO and NC detectors in 2EOL configuration are connected in the same way, it is only important to properly indicate to the control panel which detector is connected to the zone (2EOL/NO or 2EOL/NC).



4.8 Connection of sirens

The method of connection depends on the output type (high- or low-current). The high-current outputs are more suitable for control of sirens without their own power supply, while the low-current outputs – for control of sirens with their own power supply. The outputs are to be programmed as required.

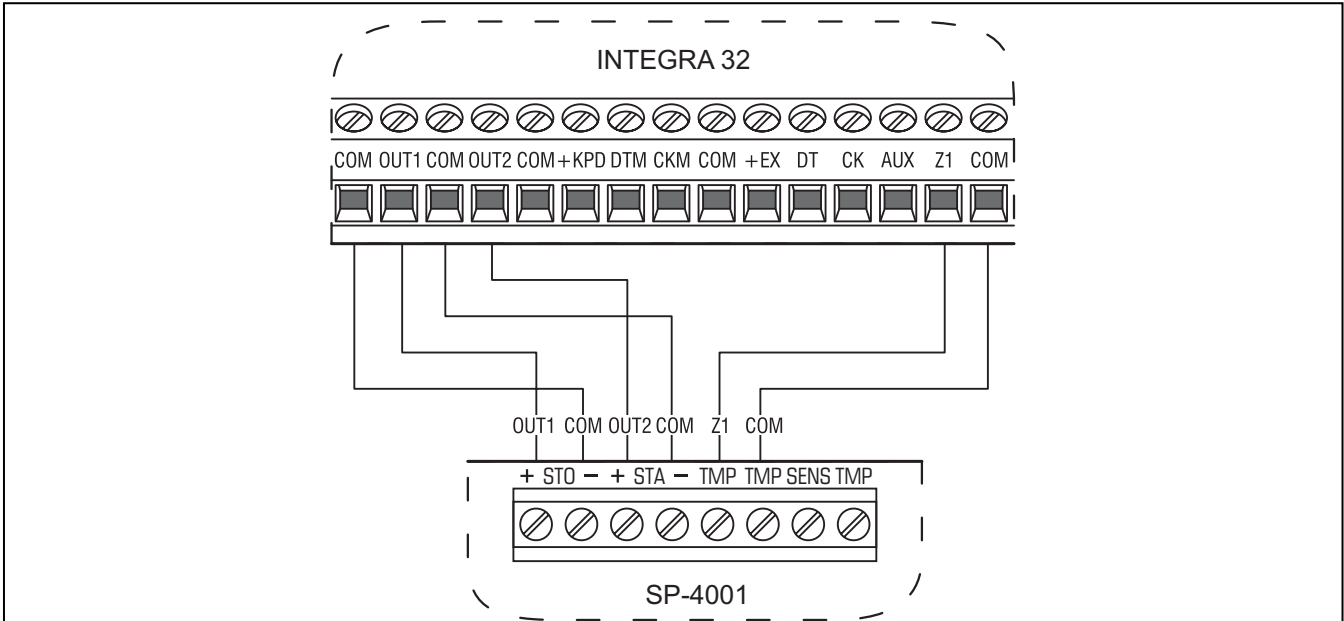

Fig. 20. Connection of siren without own power supply to high-current outputs (by the example of SP-4001 and INTEGRA 32 control panel). Optical signaling is triggered by OUT1 output, and audible signaling by OUT2 output (high-current outputs with normal polarization: when activated, +12 V voltage is supplied). Z1 is programmed as tamper zone (NC type, function 9. 24H TAMPER).

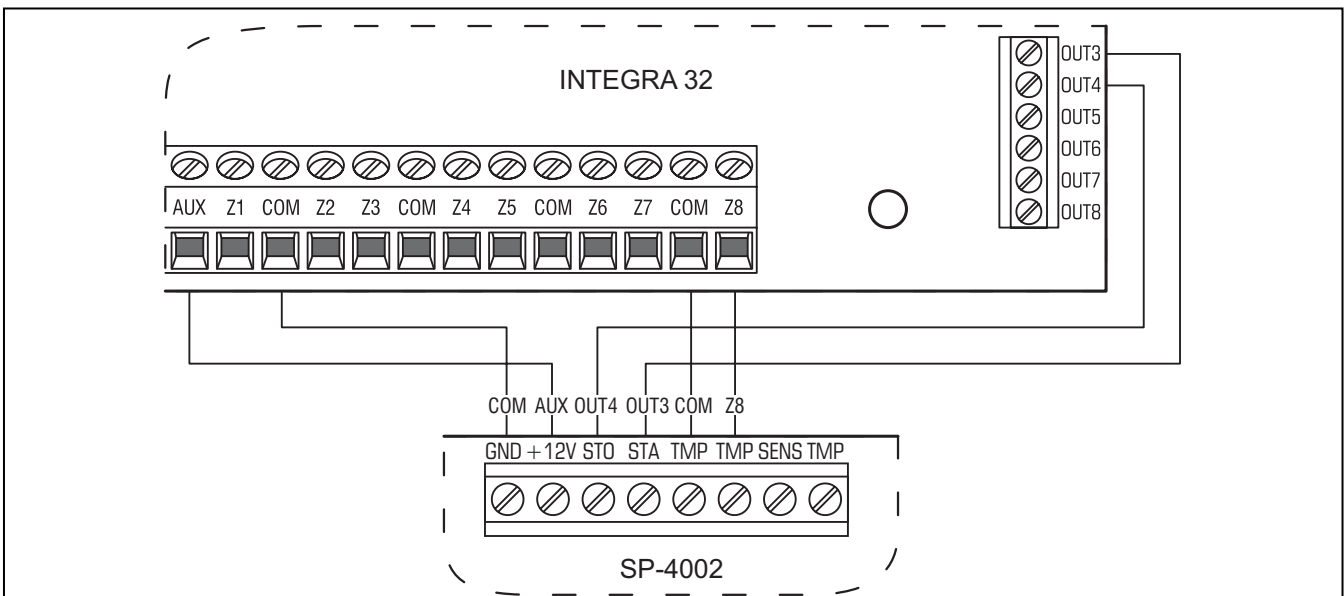

Fig. 21. Connection of siren with own power supply to low-current outputs (by the example of SP-4002 and INTEGRA 32 control panel). Audible signaling is triggered by OUT3 output, and optical signaling by OUT4 output (low-current outputs with normal polarization: when activated, they are shorted to ground). Z8 is programmed as tamper zone (NC type, function 9. 24H TAMPER).

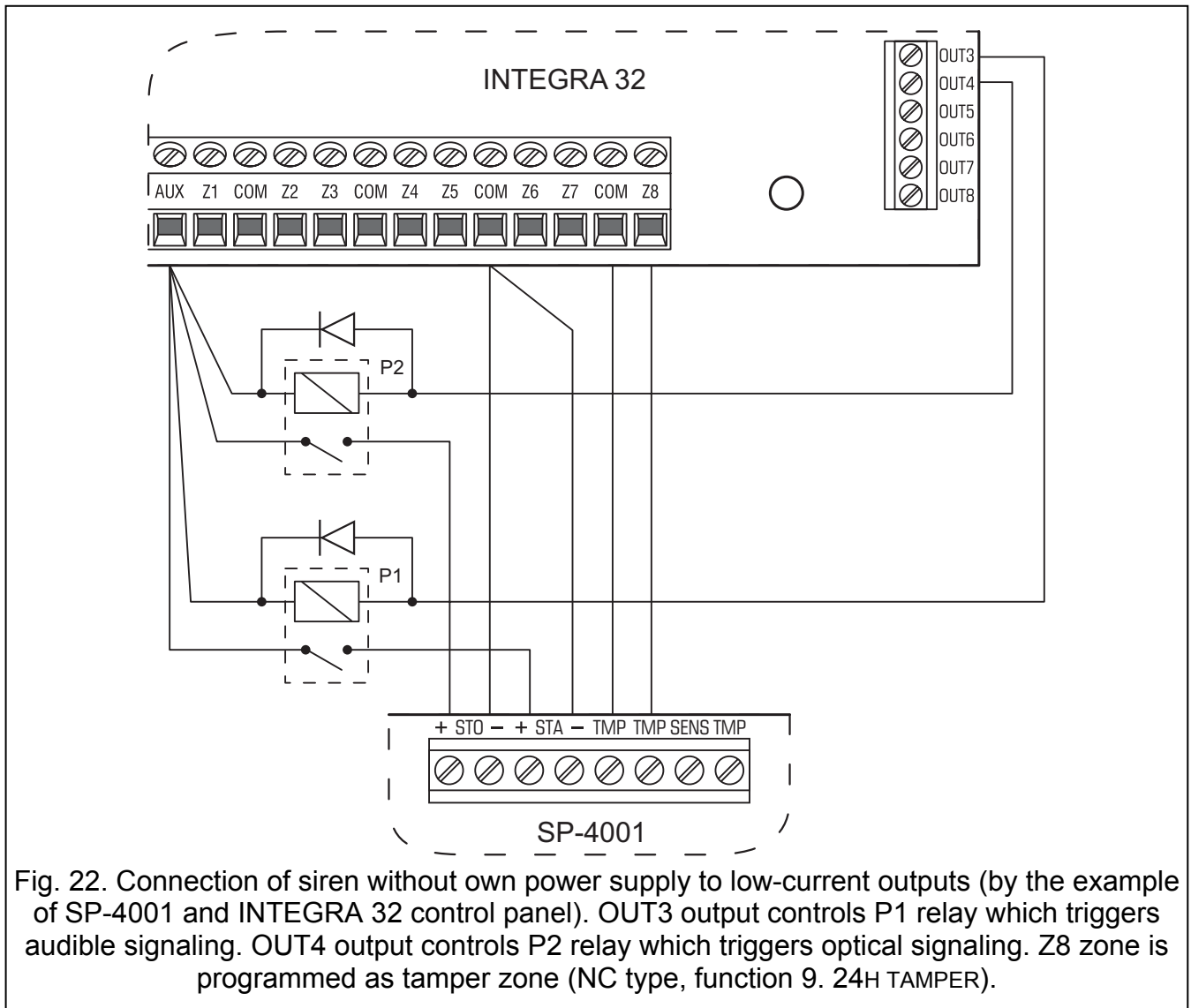

Fig. 22. Connection of siren without own power supply to low-current outputs (by the example of SP-4001 and INTEGRA 32 control panel). OUT3 output controls P1 relay which triggers audible signaling. OUT4 output controls P2 relay which triggers optical signaling. Z8 zone is programmed as tamper zone (NC type, function 9. 24H TAMPER).

Notes:

- If the programmable high-current outputs are not used, they should be loaded with 2.2 k Ω resistors.
- The programmable high-current outputs are provided with a load presence detection unit, which is active when the output is not active. If a load is connected correctly and the control panel indicates the "No output load" trouble, connect a 2.2 k Ω resistor in parallel to the load. When the siren connected to the output in parallel to the resistor 2.2 k Ω generates undesirable sounds (if not controlled), reduce the resistance value.
- It is recommended that the control panel be started without sirens connected (the high-current outputs should be loaded with 2.2 k Ω resistor). This will prevent alarm from being accidentally triggered when starting the control panel.

4.9 Connection of telephone line

If the alarm system makes use of the control panel telephone communicator (for monitoring, messaging or remote programming), it is necessary to connect the analog telephone line to the control panel. The telephone line is plugged to the terminal located in the upper right corner of the PCB. In order to ensure correct messaging function, the **control panel must be connected directly to the telephone line** (terminals marked TIP, RING), and all other equipment (telephone set, fax) – after the control panel (terminals marked T-1, R-1). Such a connection allows the control panel to fully capture the telephone line for the time of calling,

which prevents the possibility of the messaging function being blocked when the handset is picked up.

For protection of the telephone communicator against voltage surges, the $\overline{\text{PE}}$ terminal should be connected to the 230 V AC network protective conductor (PE). Never connect the $\overline{\text{PE}}$ terminal to the neutral conductor (N).

The telephone line must be made with a four-wire cable so that the control panel can be connected before the other equipment (telephone, telefax, etc.).



Do not send telephone signals and alarm system signals by one multicore cable. This may cause damage to the system in case of a high-voltage punch-through coming from the telephone.

The control panel may only be connected to analog lines only. Direct connection of the telephone circuit to ISDN lines may cause damage to the equipment.

The system installer should provide the user with necessary information on how the control panel should be connected to the telephone network.

4.10 Connection of voice synthesizers

The CLK and DTA wires of CA-64 SM synthesizer should be connected to the control panel expander bus, and the plug – to the dedicated socket. An individual address must be set in the CA-64 SM synthesizer by means of DIP-switches, in much the same way as in case of other devices connected to the expander bus (see section ADDRESSING DEVICES CONNECTED TO EXPANDER BUS).

Instead of the CA-64 SM synthesizer, it is possible to install the SATEL made SM-2 synthesizer in the system. The SM-2 enables saving and playback of single voice messages. In order to install the SM-2 synthesizer in the system, just insert the plug to the dedicated socket on control panel mainboard.

4.11 Connection of printer

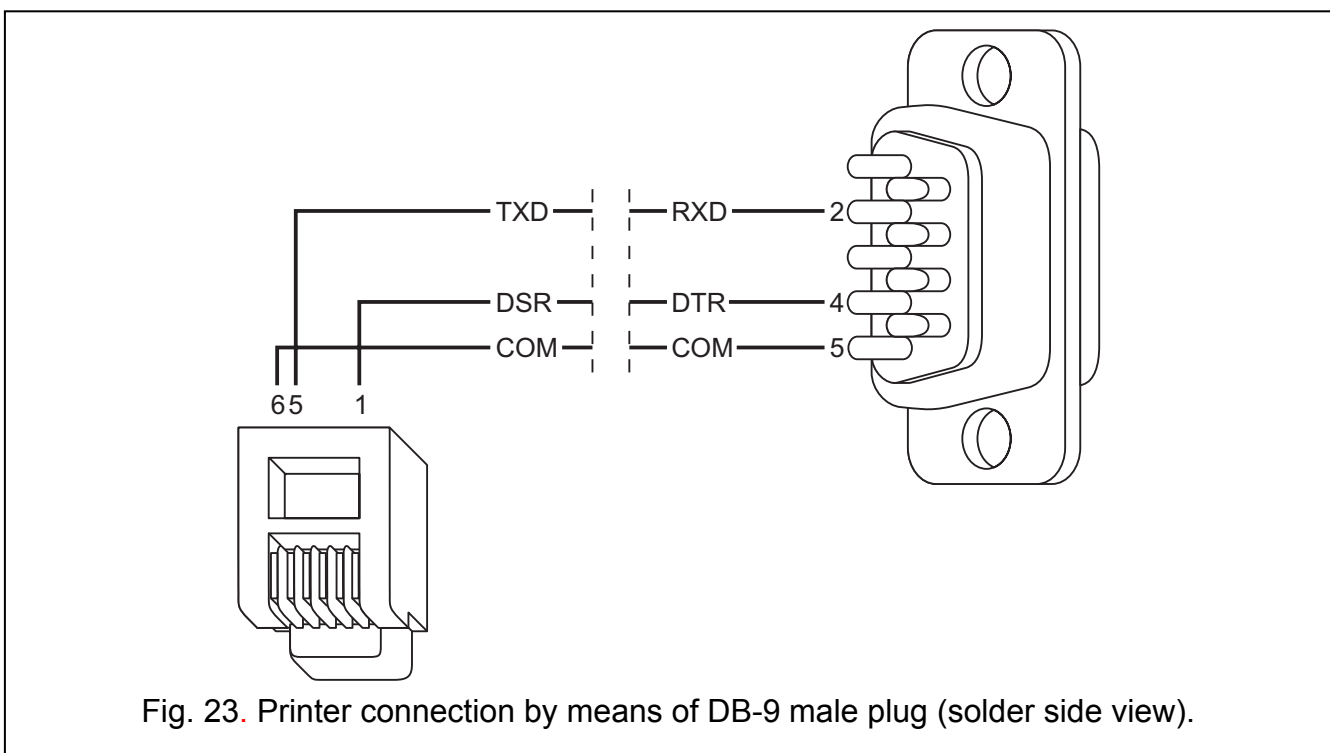

Fig. 23. Printer connection by means of DB-9 male plug (solder side view).

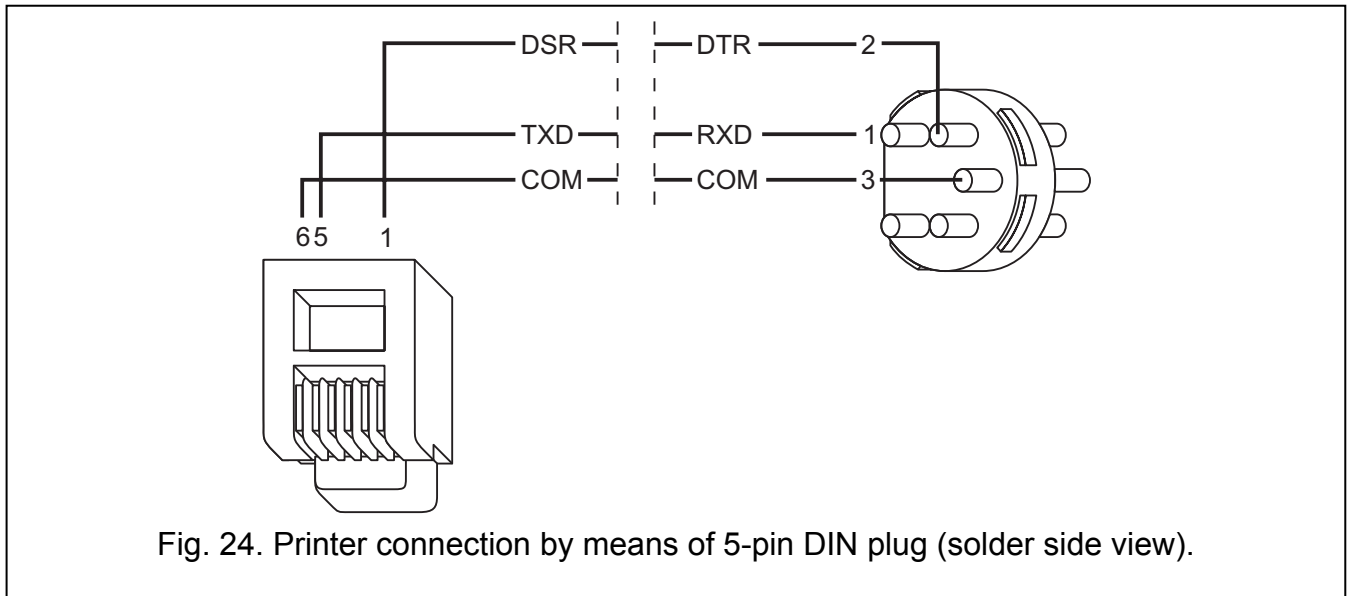

Fig. 24. Printer connection by means of 5-pin DIN plug (solder side view).

The control panel RS-232 port makes it possible to connect a printer provided with serial port. The control panel may print events in a "compressed" format (single event is printed in a single line containing up to 80 characters) or "extended" format, with names of zones, partitions, users and modules (then, the event is printed in two lines, when the printer with up to 80 characters per line is used; the descriptions of a single event are printed in one line with printers printing 132 characters per line).

4.12 Connection of power supply



Before connecting power supply, make sure that all connection operations in the system are completed.

Never connect two devices with power supply unit to one transformer.

Before adding transformer to a circuit from which it will be powered, make sure the circuit is de-energized.

Because the transformer has no mains switch, it is important that you let the owner / user of the device know how it should be disconnected from the mains (e.g. by indicating the fuse which protects the control panel supply circuit).

It is not allowed to connect a fully discharged battery (with voltage across unloaded terminals less than 11 V) to the alarm panel. If the battery is fully discharged or it has never been in use, precharge it by means of a suitable charger.

The INTEGRA 24 and INTEGRA 32 control panels must be supplied with 18 V ($\pm 10\%$) alternating voltage. It is recommended that at least 40 VA transformer be used.

The INTEGRA 64 and INTEGRA 128 control panels must be supplied with 20 V ($\pm 10\%$) alternating voltage. It is recommended that at least 60 VA transformer be used.

The transformer should be permanently connected to the 230 V AC mains. Thus, before you set about making the connections, make yourself familiar with the electric system in the facility. Make sure that the circuit you choose for powering the control panel will be always alive. The power supply circuit should be protected with a proper safety device.

A 12 V lead-acid sealed battery should be connected to the control panel as an emergency power source. The battery capacity must be adequately selected to match current

consumption in the system. According to CLC/TS 50131-1 Grade 3, the battery must ensure operation of the system without mains supply for 30 hours, when the reporting function is running in the control panel.

Note: *If the battery voltage drops below 11 V for longer than 12 minutes (3 battery tests), the control panel will indicate battery failure. When the voltage goes down to approx. 9.5 V, the battery will be disconnected.*

4.12.1 Power supply connection procedure

1. Deenergize the 230 V AC circuit to which the transformer is to be connected.
2. Connect the 230 V alternating voltage wires to the terminals of transformer primary winding.
3. Connect the terminals of transformer secondary winding to the AC terminals on module electronics board.
4. Connect the battery to the dedicated leads (red one to the battery “plus”, black one to “minus”). **The control panel will not start after connecting the battery alone.** Included in the control panel set are adapters (matching connectors) for connection of battery with twisted cable ends, therefore the battery cable ends should not be cut off.
5. Turn on 230 V AC power supply in the circuit to which the transformer is connected. The control panel will start operating.

The above mentioned power-up sequence (battery first, then 230 V AC mains) will enable the power supply unit and control panel electronic protection circuits to work properly, thus avoiding any defects of the alarm system components caused by possible installation errors. Modules fitted with their own power supply should be started in much the same way.

Caution: *Should a situation occur when total disconnection of control panel power supply is necessary, disconnect in turn the mains and the battery. When reconnecting the power supply, observe the above mentioned sequence (first the battery, then the 230 V AC mains).*

4.13 Starting the control panel

When the battery is connected and power turned on, the control panel will start. After power-up, the control panel start is proceeding in two stages:

1. First, the STARTER program starts, checking the control panel firmware for possible damage. If no error is detected, the STARTER launches the control panel program.
If an error is detected in the control panel program, the message "Load correct program to the control panel" will be displayed on LCD keypads and the STARTER program will be waiting for a new program from the computer. A program error may only occur when the procedure of control panel firmware updating is disrupted by disconnecting power supply.
2. The control panel program checks the control panel data saved in the RAM memory (the memory has a battery backup). If no error is detected, the control panel will be started with current settings.

If an error is detected in the data saved in RAM memory, the settings will be restored from FLASH memory. A copy of the settings is stored in the FLASH memory. A prompt about saving the copy of settings to FLASH memory is displayed on the LCD keypad when exiting the service mode in case the current settings are changed. In the DLOADX program, you can use the  icon to save a copy of settings to FLASH memory. Saving the data to FLASH memory is followed by a restart of the control panel.

The control panel with factory settings (new one or one after restart of settings) supports all keypads connected to the bus. It does not, however, control the status of keypad zones and tamper contacts, and does not provide for programming the security system parameters.

Prior to programming the system, you should:

1. Set individual, correct addresses in keypads.
2. Start the keypad identification function (SERVICE MODE →STRUCTURE →HARDWARE →IDENTIFICATION →LCD KEYPADS ID.).
3. Start the expander identification function (SERVICE MODE →STRUCTURE →HARDWARE →IDENTIFICATION →EXPANDERS ID.).

5. Compliance with CLC/TS 50131-3 requirements

To meet the requirements of CLC/TS 50131-3:

- for each detector provided with the antimasking function, reserve two control panel zones: a supervision zone, to register violations of the detector, and a technical one, to register triggering of the antimasking feature. If the "maximum zone violation time" programmed for the technical zone is shorter than the antimasking relay cut-off time, a detector trouble will be reported at an attempt to cover the detector;
- for all the expansion modules with integrated power supplies, an additional supervised overcurrent protection (like the ZB-2) must be used for each power supply output. Overload signaling output (OVL) should be connected to zone programmed as type 62 (TECHNICAL – OVERLOAD).

6. Basic specifications

6.1 Technical data – alarm control panels

		Control panel type			
		INTEGRA 24	INTEGRA 32	INTEGRA 64	INTEGRA 128
Mainboard supply voltage, nominal ($\pm 10\%$)		18 V AC, 50–60 Hz		20 V AC 50–60 Hz	
Mainboard current consumption	minimum	110 mA	115 mA	135 mA	
	typical	121 mA	127 mA	149 mA	
	maximum	204 mA	234 mA	337 mA	
Power supply type, control panel		A			
Power supply unit voltage, nominal ($\pm 10\%$)		13,8 V DC			
Output voltage range		9,5 V...14 V			
Batt. failure voltage thr. ($\pm 10\%$)		11.0 V			
Battery cut-off voltage ($\pm 10\%$)		9.5 V			
Power supply load capacity		1,2 A		3 A	
Load capacity, high-current programmable outputs ($\pm 10\%$)		2 A		3 A	
Load capacity, low-current programmable outputs		50 mA			
Load capacity, +KPD output ($\pm 10\%$)		500 mA		2.5 A	
Load capacity, AUX output		500 mA			
Load capacity, +EX output		500 mA			
Load capacity, +EX1, +EX2 outputs				2.5 A	
Battery charging current ($\pm 20\%$)		350 mA	400/800 mA	500/1000 mA	
Environmental class		II			
Operational temperature range		-10 °C...+55 °C			
Weight		178 g	211 g	341 g	341 g

6.2 Technical data – keypads

		Keypad type				
		INT-KLCD-GR INT-KLCD-BL	INT-KLCDR-GR INT-KLCDR-BL	INT-KLCDK-GR	INT-KLCDL-GR INT-KLCDL-BL	INT-KLCDS-GR INT-KLCDS-BL
Supply voltage, nominal ($\pm 15\%$)		12 V DC				
Current consumption	minimum	15 mA	55 mA	25 mA	55 mA	30 mA
	typical	17 mA	60 mA	30 mA	61 mA	33 mA
	maximum	101 mA	156 mA	110 mA	147 mA	151 mA
Housing dimensions width x height x thickness		140x126x26 mm		160x126x38 mm	145x115x26 mm	114x94x23.5 mm
Environmental class		II				
Operational temperature range		-10 °C...+55 °C				
Weight		231 g	236 g	317 g	217 g	141 g

6.3 Technical data – expansion modules

		Module type												
		INT-S-GR INT-S-BL	CA-64 E	CA-64 EPS	CA-64 O			CA-64 OPS			CA-64 PP	CA-64 ADR	ADR-MOD	CA-64 SM
Supply voltage, nominal (±15%)		12 V DC	12 V DC	18 V AC	12 V DC			18 V AC			18 V AC	18 V AC	12 V DC	12 V DC
Current consumption	minimum	22 mA	16 mA	35 mA	15 mA			35 mA			41 mA	42 mA	1,5 mA	15 mA
	average	24 mA	18 mA	39 mA	17 mA			39 mA			45 mA	46 mA	1,8 mA	17 mA
	maximum	66 mA	70 mA	91 mA	116 mA			138 mA			194 mA	55 mA	5 mA	72 mA
Supply unit capacity		-	-	1.2 A	-			2.2 A			2.2 A	2.2 A	-	-
Current-carrying capacity of AUX output with ZB-2 module connected								1.7 A			1.7 A	1.7 A		
Output voltage, nominal		-	-	13.8 V	-			13.8 V			13.8 V	13.8 V	-	-
Output voltage	minimum	-	-	9.5 V	-			9.5 V			9.5 V	9.5 V	-	-
	maximum	-	-	14 V	-			14 V			14 V	14 V	-	-
Battery charging current (±20%)		-	-	400/800 mA	-			400/800 mA			400/800 mA	400/800 mA	-	-
Battery failure voltage thr. (±10%)		11 V												
Battery cut-off voltage (±10%)		9.5 V												
Battery charging time, maximum		24 h												
Environmental class		II												
Operational temperature range		-10°C...+55°C												
Weight		110 g	47 g	131 g	OC	R	ROC	OC	R	ROC	190 g	125 g	9 g	41 g
					74 g	118 g	96 g	155 g	197 g	181 g				

6.4 Battery selection



The control panel power supply unit has been designed for work with lead batteries or other batteries with a similar charging curve.

It is impermissible to connect to the alarm panel a fully discharged battery (with voltage on unloaded terminals less than 11 V). To avoid damage to the equipment, a fully discharged/never used battery should be precharged with the use of a proper charger.

	Control panel type			
	INTEGRA 24	INTEGRA 32	INTEGRA 64	INTEGRA 128
Battery type	lead-acid, sealed			
Capacity, maximum	8 Ah	19 Ah	24 Ah	24 Ah
Max. charging time, 80% capacity	24 h			

The batteries should be individually selected for each system. Presented below are some examples of accumulator batteries energy balance as recommended by EN 50131-1:2005 for the power supply units Type A, Grade 3. They assume that in the event of mains supply failure the alarm system will have to work for 30 hours on emergency power supply, while being able to remotely report the on the power supply trouble.

6.4.1 INTEGRA 24 – battery 7 Ah

The available 30 hr current for the 7 Ah battery is:

$$I_{30h} = 7 \text{ Ah}/30 \text{ h} \approx 0.233 \text{ A} \text{ (233 mA)}$$

The average currents consumed by the components of the model alarm system based on the INTEGRA 24 control panel:

- mainboard, INTEGRA 24: 121 mA;
- zones, NC: 4 x 5 mA;
- keypad, INT-KLCD-GR: 17 mA;
- partition keypad, INT-S-GR: 24 mA;
- 2 movement detectors, PIR: 2 x 10 mA;
- 2 magnetic detectors: 0 (require no power supply).

$$\sum I_s = 0.121 + 4 \times 0.005 + 0.017 + 0.024 + 2 \times 0.010 = 0.202 \text{ A} \text{ (202 mA)}$$

The summed average current consumed by the system is 202 mA, therefore it is lower than the current that can be provided by the battery.

6.4.2 INTEGRA 32 – battery 7 Ah

The available 30 hr current for the 7 Ah battery is:

$$I_{30h} = 7 \text{ Ah}/30 \text{ h} \approx 0.233 \text{ A} \text{ (233 mA)}$$

The average currents consumed by the components of the model alarm system based on the INTEGRA 32 control panel:

- mainboard, INTEGRA 32: 127 mA;
- zones, NC: 8 x 5 mA;
- keypad, INT-KLCD-GR: 17 mA;
- partition keypad, INT-S-GR: 24 mA;

- 2 movement detectors, PIR: 2 x 10 mA;
- 6 magnetic detectors: 0 (require no power supply).

$$\sum I_s = 0.127 + 8 \times 0.005 + 0.017 + 0.024 + 2 \times 0.010 = 0.228 \text{ A (228 mA)}$$

The summed average current consumed by the system is 228 mA, therefore it is lower than the current that can be provided by the battery.

6.4.3 INTEGRA 32 – battery 17 Ah

The available 30 hr current for the 17 Ah battery is:

$$I_{30h} = 17 \text{ Ah}/30 \text{ h} \approx 0.566 \text{ A (566 mA)}$$

The average currents consumed by the components of the model alarm system based on the INTEGRA 32 control panel:

- mainboard, INTEGRA 32: 127 mA;
- zones, NC: 8 x 5 mA;
- 2 keypads, INT-KLCD-GR: 2x17 mA;
- 2 partition keypads, INT-S-GR: 2x24 mA;
- 3 movement detectors, PIR: 3 x 10 mA;
- 3 microwave detectors: 3 x 25 mA;
- 2 magnetic detectors: 0 (require no power supply).

$$\sum I_s = 0.127 + 8 \times 0.005 + 2 \times 0.017 + 2 \times 0.024 + 3 \times 0.010 + 3 \times 0.025 = 0.354 \text{ A (354 mA)}$$

The summed average current consumed by the system is 354 mA, therefore it is lower than the current that can be provided by the battery.

6.4.4 INTEGRA 64/128 – battery 17 Ah

The available 30 hr current for the 17 Ah battery is:

$$I_{30h} = 17 \text{ Ah}/30 \text{ h} \approx 0.566 \text{ A (566 mA)}$$

The average currents consumed by the components of the model alarm system based on the INTEGRA 64 or INTEGRA 128 control panel:

- mainboard, INTEGRA 64/128: 149 mA;
- zones, NC: 16 x 5 mA;
- 3 keypads, INT-KLCD-GR: 3x17 mA;
- 4 partition keypads, INT-S-GR: 4x24 mA;
- 10 movement detectors, PIR: 10 x 10 mA;
- 3 microwave detectors: 3 x 25 mA;
- 2 magnetic detectors: 0 (require no power supply).

$$\sum I_s = 0.149 + 16 \times 0.005 + 3 \times 0.017 + 4 \times 0.024 + 10 \times 0.010 + 3 \times 0.025 = 0.551 \text{ A (551 mA)}$$

The summed average current consumed by the system is 551 mA, therefore it is lower than the current that can be provided by the battery.

ATTENTION!

An efficient security system does not prevent burglary, assault or fire from happening, however it diminishes the risk that such a situation will cause no alarm or notification. Therefore, the SATEL Company recommends that operation of the whole security system be regularly tested.

All circuits are designated by their version and date. The program periodically checks the memory content. The program run is supervised by hardware means. If a memory error occurs, the trouble signal is generated. In case of a run-time error, the processor is restarted.

7. History of the manual updates

Given below is a description of changes as compared with the manual for the control panel with firmware in version v1.04.

DATE	PROGRAM VERSION	INTRODUCED CHANGES
2007-08	1.05	<ul style="list-style-type: none"> • Added information on SIA, a new format of transmission to monitoring station (p. 4). • Added information on a new method of zone configuration: the zone status can change as the output status changes (p. 5 and 23). • Added information on new devices supported by the control panel (p. 7-9). • Added information on the optional connection of roller shutter motion detectors (rope detectors) and vibration detectors to the CA-64 E and CA-64 EPS expanders (modules in the version manufactured from 2007) (p. 7, 7 and 23). • Modified contents and figures in the section on connecting expansion modules to the control panel (p. 18). • Added information on the optional programming of resistor values for EOL and 2EOL configuration in case of zones in the CA-64 E and CA-64 EPS expanders (modules in the version manufactured from 2007) (p. 22).
2008-05	1.06	<ul style="list-style-type: none"> • Section "General features of control panels" has been modified (p. 3). • Information on INT-RX data converter has been added (p. 7). • Section "Control panel installation" has been modified and renamed into "System installation" (p. 9): <ul style="list-style-type: none"> – section "Installation plan" has been added (p. 9); – section "Estimation of system current consumption" has been added (p. 9); – section "Cabling" has been added (p. 9); – section "Installation of control panel mainboard" has been added (p. 10); – section "Connecting LCD keypads" has been modified and renamed into "Connecting LCD keypads and other devices to keypad bus" (p. 14); – section "Connecting expansion modules" has been modified and renamed into "Connecting devices to expander bus" (p. 18); – section "Connection of sirens" has been modified (p. 26); – section "Connection of telephone line" – information on connecting dialer protection terminal has been added (p. 28); – section "Connection of voice synthesizers" has been modified (p. 28); – figures in section "Connection of printer" have been changed (p. 28); – section "Connection of power supply" has been modified (p. 29); – section "Starting the control panel" has been modified (p. 30).

SATEL sp. z o.o.
ul. Schuberta 79
80-172 Gdańsk
POLAND
tel. + 48 58 320 94 00
info@satel.pl
www.satel.pl