

The RX2K (RX4K) multi-channel radio controller has been designed for application in the security systems, where it can serve control functions for arming partitions and bypassing partitions or detectors, or even panic buttons. Owing to its expanded configuration options, it can be successfully used in all situations where wireless control is required.

The radio controller is fitted with electromagnetic relays which make possible direct control of the electric equipment operation. It comes as a two-channel (RX2K) and/or four-channel (RX4K) device, the both versions differing in the number of the relays installed. To perform the control function (as transmitters), two- or four-button remote controls are designed. High resistance of the remote controls to environmental changes ensures a stable performance and a high comfort of the controller use. The construction, based on the Microchip Technology Inc. component parts, which use the dynamically changed KEELOQ[®] code for the transmission between transmitter and receiver, ensures both the safety of use and the resistance to spurious control signals coming from other equipment. The multi-channel controller can work together with 340 remote controls. The controller can only handle the SATEL remote controls.

Interfacing with the security systems is facilitated by the inputs informing of the system status, which make for an easy arrangement of the signaling of arming/disarming and clearing alarm.

WARNINGS

The control panel main board contains electronic components sensitive to electric charges. Prior to installation, these charges must be removed. During installation, avoid touching any elements on the control panel main board.

Making any construction changes or unauthorized repairs is prohibited. This applies, in particular, to modification of assemblies and components.

It is recommended that in the remote controls the producer's required battery should be used.

CAUTION! The old batteries must not be thrown away, but disposed of as required by the existing regulations (European Directives 91/157/EEC and 83/86/EEC).

HOOKUP DESCRIPTION

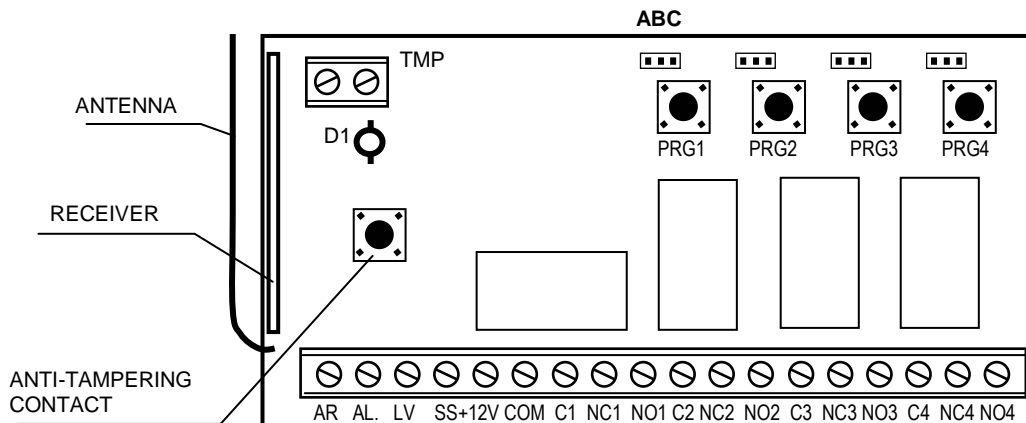

Figure 1. View of the four-channel controller board.

DESCRIPTION OF TERMINALS:

- AR** – input of signal indicating the security system armed mode
 - AL** – alarm signal input
 - LV** – output of remote control low battery signal (OC)
 - SS** – signaling device control output (OC)
 - +12V** – supply voltage input (direct voltage 9 to 16V)
 - COM** – ground
 - C_n** – common terminal of relay
 - NC_n** – normally-closed terminal of relay
 - NO_n** – normally-open terminal of relay
 - TMP** – anti-tampering contact terminals
- } n – number of relay (channel)

The **D1** (two-color) LED is the module operation indicator, which helps in programming the controller parameters. In normal condition, the color of its light is green, changing into red when a signal is received by the controller from the transmitter (remote control). The blinking red light means that the remote control battery is low.

The programming buttons PRG1 to PRG4 are designed for programming the remote controls working together with the controller and the monostable switching time of the relay. Additionally, the **PRG1** button is used for programming remote controls working together with the controller.

The three pins (ABC) situated at the PRG_n buttons are intended for setting the operation mode of the relay corresponding to the channel **n**).

PROGRAMMING OF REMOTE CONTROLS

The controller offers extensive options for remote control configuration. Control can be available either on all channels, or just on selected ones. It depends on which button number is used for programming the remote control. If, e.g., the four-button remote control is entered into the memory of the four-channel controller with the **PRG2** button, the remote control will be able to work on the channels **2, 3 and 4**. The channel 1 will be unavailable to it. The remote control active buttons will be 1, 2 and 3, and the button 4 will be disabled. In turn, when the two-button remote control is entered into the controller memory with the PRG2 button, operation will be possible on the channels 2 and 3. Detailed possibilities to control the selected channels are shown in the table below:

		Remote control button No. Programming button	Four-button remote control				Two-button remote control		Controller channel numbers
			1	2	3	4	1	2	
RX4K	PRG1		1	2	3	4	1	2	
	PRG2		2	3	4		2	3	
	PRG3		3	4			3	4	
	PRG4		4				4		
RX2K	PRG1		1	2			1	2	
	PRG2		2				2		

The controller only serves the remote controls if entered into its memory by the following procedure:

1. Press one of the PRG buttons – the LED will start blinking in green.
2. Press the remote control button – the LED will change its color into (blinking) red.
3. Press again the same remote control button – the LED will light in steady green color – the remote control has been entered into the memory.

If the memory is already full or if the remote control is incorrect (made by another manufacturer), the first depression of the remote control button will make the controller return to its normal condition.

Clearing the remote control from the controller memory is only possible by erasing the whole memory contents. In order to do so, press and hold down the PRG1 button for about 3 seconds (the LED will blink once in red), release the button for about 1 second, and then press it again and hold down for 3 seconds. The LED will start blinking in red, and then it will return to the green color when the memory is cleared. The controller is now ready for programming the remote controls.

IMPORTANT:

- *When closing the housing, be particularly careful so as not to depress the programming buttons with cables .*
- *The lifetime of remote control batteries depends on how often they are used. The batteries must be periodically checked (e.g. by watching how the D1 LED shines when the remote control button is being depressed, or by means of the controller LV output) and replaced with new ones.*

SETTING THE RELAY OPERATING MODE

The relay can work in one of the three modes (selected by means of the jumper and ABC pins):

1. Bistable (all pins open) – each depression of the remote control button changes the relay status to the opposite one.
2. Monostable (pins A and B closed) – the relay is activated for a determined time.
3. Pulse (pins B and C closed) – the relay is active as long as the remote control button is depressed.

The time of monostable switchover is set in the following way (by default and after clearing the remote controls, the time is set to 5 seconds and can be changed within the range **of 1 to 255 seconds**):

- Press the PRGn button twice (n - the number of channel to be programmed) – the LED will go out.
- Press the remote control button – the LED will start blinking alternately in green and red.
- Measure off the programmed time and press again the remote control button – the LED will light in steady green color.

INTERFACING WITH THE SECURITY SYSTEM

When signals informing of the security system armed mode and alarm (time of alarm to be cleared) are fed to the controller inputs, the function of generating appropriate signals on the SS output is activated. The armed mode (AR) and the alarm (AL) are indicated by grounded input. The signaling is effected by grounding the SS output for the time of impulse (0.16 second; current-carrying capacity 0.5A).

- One signal – arming.
- Two signals – disarming.
- Four signals – disarming and clearing alarm.

The AR and AL inputs are monitored for 4 seconds after the remote control is used– which means the AR input status must be changed within that time, or the SS output will not generate any signals. Thus, arming or disarming performed from the keypad will generate no signals on the SS output of the controller.

EXAMPLE:

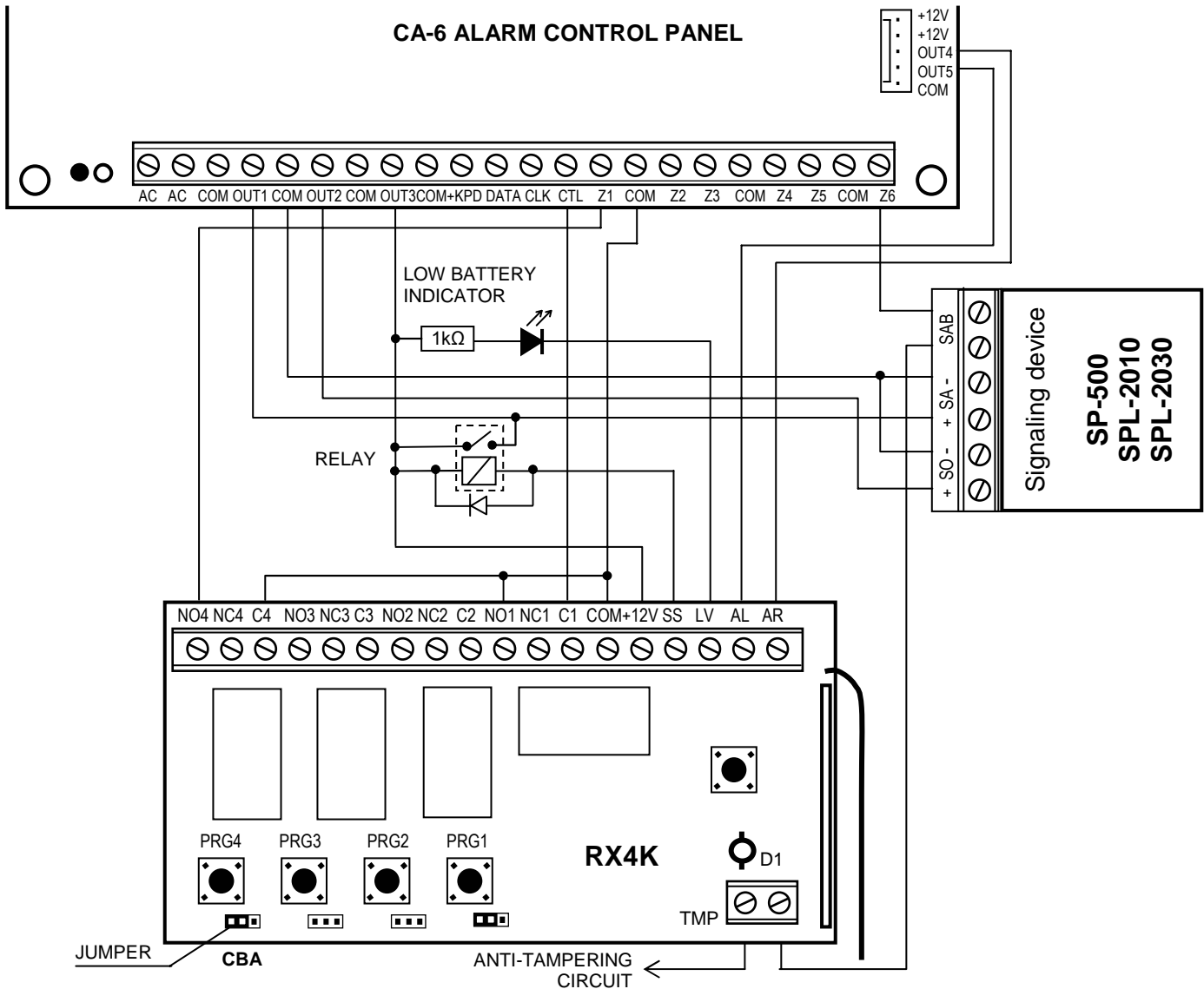

Figure 2. Example of armed mode remote control in the SATEL CA-6 control panel with indication of remote control use on the external signaling device.

In the above example, the control panel armed mode is controlled by means of the remote control button No. 1, while the button No. 4 is used for triggering the silent PANIC alarm. The remote control has been entered into the memory with the PRG1 button. The relays 1 and 4 work in the pulse mode (shorted B and C at PRG1 and PRG4) and connect ground (0V) to the CTL and Z1 inputs of the panel. In order to arm or disarm the system, press and hold down the remote control button No. 1 until you hear a beep from the alarm signaling device. The panic alarm is triggered with the button No. 4. To eliminate accidental triggering of the alarm, an appropriate sensitivity of the Z1 input (for example, 3 seconds) must be programmed in the control panel.

The figure above shows also a simple way of providing a remote control low battery indicator.

To implement the example, the following parameters must be programmed in the CA-6 panel:

- OUT1 - Time alarm (+12V when the output is active);
- OUT2 - Alarm to be cleared (+12V when the output is active);
- OUT3 - Supply output (+12V);
- OUT4 - Armed mode indicator (OC type output – program +12V when active)
- OUT5 - Alarm to be cleared (OC type output – program +12V when active);
- CTL - Arming/disarming one or both partitions (FS 125);

- Z1 - 24H silent line (using remote control button No. 4 sends code to monitoring station);
- Z6 - 24H loud line (anti-tampering circuit).

The presented example shows just one of the many possible applications of the controller.

TECHNICAL DATA

Range in open area.....	up to 100m (obstructions between transmitter and receiver reduce the device operating range)
Number of controlled channels.....	2 / 4
Power supply voltage	DC 9 to 16V
Current consumption, minimum	approx. 13mA
Current consumption, maximum for 2/4K.....	approx. 50/65mA
Max. switching current of relay contacts.....	1,25A/AC/DC
Current-carrying capacity of relay contacts	2A/AC/DC
Max. switching voltage of relay contacts	150V DC/100V AC
Time control range in monostable mode	1 do 255s
Current-carrying capacity of LV (OC) output	50mA
Current-carrying capacity of SS (OC) output.....	500mA
Working frequency	433,05 – 434,79MHz
Working temperature range.....	-10 to +50 °C
Dimensions:	
Receiver	117x72x23mm
Remote control, two-channel.....	50x35x11mm
Remote control, four-channel	55x37x16mm
Battery type:	
For remote control, two-channel (P-2).....	27A 12V
For remote control, four-channel (P-4)	23A 12V

CAUTION! The old batteries must not be thrown away, but disposed of as required by the existing regulations (European Directives 91/157/EEC and 83/86/EEC).

Latest EC declaration of conformity and product approval certificates can be downloaded from our Web site www.satel.pl



SATEL sp. z o.o.
 ul. Schuberta 79
 80-172 Gdańsk
 POLAND
 tel. + 48 58 320 94 00
info@satel.pl
www.satel.pl