

The VMG-16 Voice Message Generator is designed for playback (reproduction) of prerecorded messages. It can work in conjunction with the CA-64 and INTEGRA series alarm control panels as an output expander, as well as with any other equipment capable of controlling the generator inputs.

1. Description of electronics board

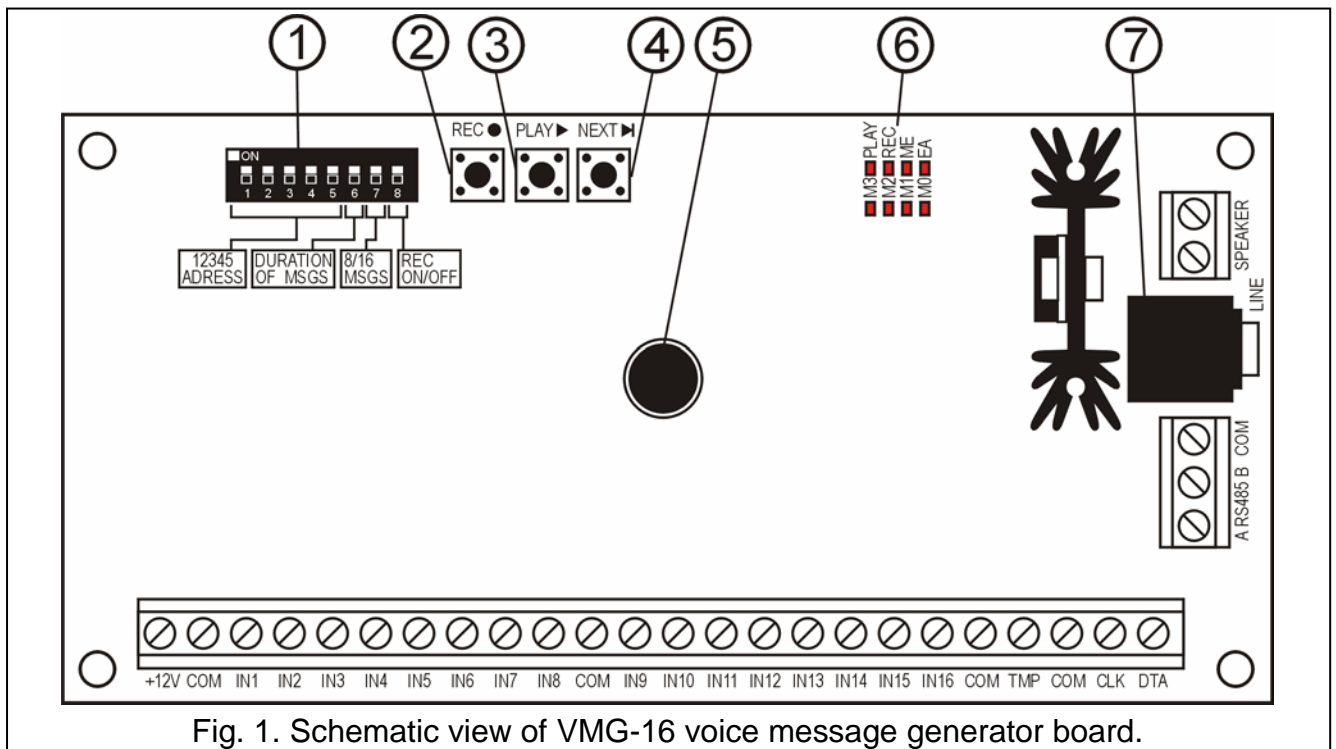

Fig. 1. Schematic view of VMG-16 voice message generator board.

Legend:

- 1 – **package of DIP-switches** – setting individual module address and module operating options (see: DIP-SWITCHES).
- 2 – **REC button** – recording messages;
- 3 – **PLAY button** – playing back recorded messages;
- 4 – **NEXT button** – switching between successive messages;
- 5 – **microphone**;
- 6 – **LED indicators** (see: LED SIGNALING):
 - M0...M3** – message number;
 - PLAY** – message playback;
 - REC** – message recording;
 - ME** – message memory full;
 - EA** – supply/communication with control panel.
- 7 – **LINE socket** – connecting headset or external audio amplifier.

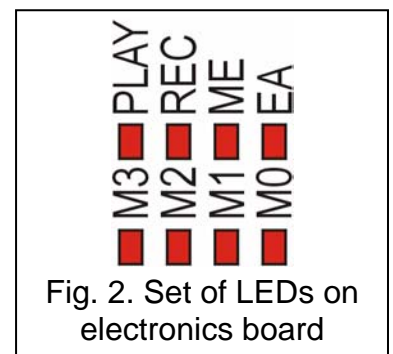

Fig. 2. Set of LEDs on electronics board

Description of terminals:

+12V – power supply input.

COM – common ground.

IN1...IN16 – inputs to generate corresponding messages (interaction with any device).

TMP – tamper input (NC).

CLK, DAT – communication bus terminals.

A RS485 B – RS-485 port terminals;

SPEAKER – terminals for connecting 8Ω loudspeaker. Output power regulated up to 6W.

1.1 DIP-switches

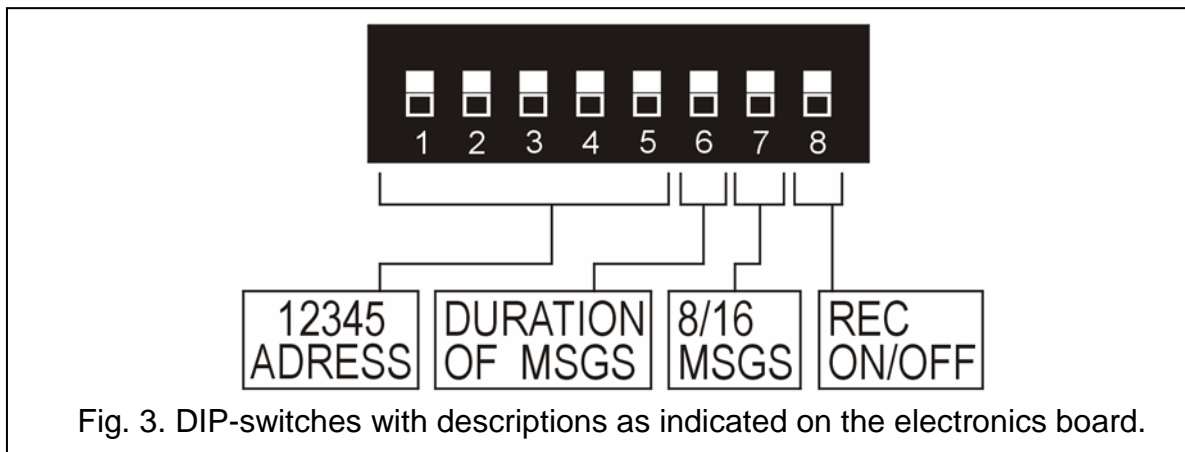

Fig. 3. DIP-switches with descriptions as indicated on the electronics board.

The switches 1 to 5 are used for setting the module address. The address, which is indispensable for the VMG-16 generator to interface with the CA-64/INTEGRA control panels, must differ from the addresses of the other modules connected to the expander bus of the control panel. In order to determine the expander address, sum up the values set on particular switches, according to Table 1.

Switch number	1	2	3	4	5
Numerical value (for switch in ON position)	1	2	4	8	16

Table 1.

The five switches enable addresses to be assigned to 32 expanders (numbers from 0 to 31). Addresses of the expanders connected to one bus may not repeat, while the addressing order can be random. It is recommended that you assign consecutive addresses, starting from zero, to expanders and modules to be connected to one bus. Thus you can prevent any problems from arising during expansion of the system.

When the generator is not used with the CA-64 or INTEGRA alarm control panels, position of the switches 1–5 is unimportant.

The switch 6 makes it possible to select the message length: either fixed (the switch in OFF position) or variable (the switch in ON position). In the case of fixed length messages, up to 16 messages of 15-second duration can be recorded. In the case of variable length messages, the total duration of recorded messages may not exceed 4 minutes.

The switch 7 relates only to operation with the CA-64/INTEGRA control panels. It is used for determination of the number of messages to be played back by the generator: 16 (the switch in OFF position) or 8 (the switch in ON position). The VMG-16 generator to play back 8 messages will be identified in the system as one output expander and will take one address. The VMG-16 generator to play back 16 messages will be identified in the system as two output expanders and will take 2 addresses. This should be borne in mind when addressing

the module, because the other address to be assigned to the generator is the one set on the switches + 1 (if the address 31 is set on the switches, the other address assigned to the generator will have the value 0). If this address is already taken, the control panel will be unable to properly complete the identification.

The switch 8, when in the ON position, enables recording of messages. When in the OFF position, it disables the message recording feature.

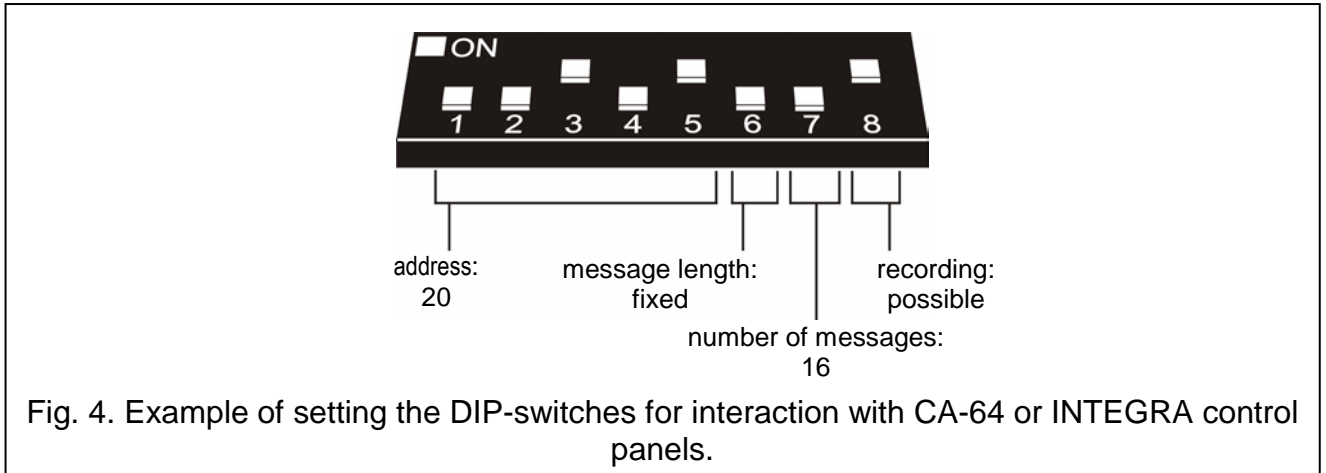

Fig. 4. Example of setting the DIP-switches for interaction with CA-64 or INTEGRA control panels.

1.2 LED signaling

The LED indicators designated M0, M1, M2 and M3 inform which message is currently being recorded/played back. Switching to the next message is done by means of the NEXT button. You can determine the message number by using Table 2.

Message number	LED indicator			
	M3	M2	M1	M0
1	□	□	□	□
2	□	□	□	■
3	□	□	■	□
4	□	□	■	■
5	□	■	□	□
6	□	■	□	■
7	□	■	■	□
8	□	■	■	■
9	■	□	□	□
10	■	□	□	■
11	■	□	■	□
12	■	□	■	■
13	■	■	□	□
14	■	■	□	■
15	■	■	■	□
16	■	■	■	■

□ – LED "off"
 ■ – LED "on"

Table 2.

The LED designated PLAY is ON when the message is being played back.

The LED designated REC is ON when the message is being recorded.

The LED designated ME is ON when the VMG-16 generator operates in the mode of handling variable-length messages, and the module message memory is full.

The LED designated EA goes ON after power-up. When working in conjunction with the CA-64/INTEGRA control panels, the LED is blinking with a changing frequency to indicate communication (it is ON when the module has failed to be identified in the system, or when the STARTER program is running).

Additionally, the LEDs serve as volume level indicators of the messages being played back (see: VOLUME LEVEL CONTROL). Level 1 is indicated by the M3 LED being "ON", Level 2 – by the M3 and M2 LEDs being "ON", etc., until Level 8, when all the LEDs are "ON".

2. Installation and startup of the VMG-16 module



All connections are to be made with power supply disconnected.

2.1 Interacting with CA-64/INTEGRA alarm control panels

1. Using the DIP-switches, set the corresponding address and options related to the module operation.
2. Connect the CLK, DTA and COM terminals with cables to the expander bus on the control panel main board.
3. Connect the loudspeaker to the SPEAKER terminals, or the audio amplifier/headset to the LINE socket, as may be required.
4. Connect the housing tamper contact cables to the TMP and COM terminals. If no tamper contact is to be connected to the TMP input, short-circuit the TMP terminal to the COM ground.
5. Connect the module supply cables to the +12V and COM terminals. The generator supply voltage is not necessarily be provided from the control panel main board. A power supply unit or another expander with power supply can be used for this purpose.
6. Turn on power supply of the security alarm system. The LED designated EA will come on.
7. Start the EXPANDER IDENTIFICATION function in the LCD keypad (→SERVICE MODE →STRUCTURE →HARDWARE →IDENTIFICATION). The identification completed, the EA LED will start blinking.
8. Program suitably the alarm system outputs assigned to the expander:
 - select the output reaction type, i.e. define the circumstances when the message will be played back;
 - enable the "Polarization" option.

Note: *The message will be played back once, irrespective of the ON-time of the control panel output. If the message is to be played back repeatedly, the "Pulsation" option should be enabled for the output.*

9. Quit the SERVICE MODE and save the changes to the control panel memory.

2.2 Interacting with any control device

1. Using the DIP-switches, set the options related to the module operation.
2. Connect the generator inputs with cables to the control device outputs.
3. Connect the loudspeaker to the SPEAKER terminals, or the audio amplifier/headset to the LINE socket, as required.

4. Connect the module supply cables to the +12V and COM terminals. The supply voltage can be provided from control device or any power supply unit with 12V DC output voltage.
5. Turn power supply on. The LED designated EA will come on.

3. Operating the voice message generator

3.1 Recording messages

Depending on the settings of DIP-switches, 8 or 16 messages with a fixed or variable length can be recorded.

In order to record a message, you should:

1. Set the switch 8 in ON position.
2. Using the NEXT button, select the number of message to be recorded (the number is displayed on the M3...M0 LEDs).
3. Press and hold down the REC button. The REC LED will go on.
4. Say the message words.
5. Release the REC button. The REC LED will go off.

Notes:

- *In the fixed length message handling mode (DIP-switch 6 in OFF position), when the recording time exceeds 15 seconds, the recording will be stopped automatically.*
- *Changing the generator from the fixed length message handling mode to the variable length message handling mode (or the other way round) will require re-recording of all the messages.*
- *In the variable length message handling mode, replacement of any message with another one (having a different length) will make it necessary to re-record all the subsequent messages.*

3.2 Playing back messages

If the VMG-16 generator operates in conjunction with the CA-64/INTEGRA control panel as an output expander, the messages are played back when the corresponding output of the security system is activated: the 1st message on activating the first in turn expander output, the 2nd one on activating the second in turn expander output, etc.

If the VMG-16 generator works in conjunction with another control device (e.g. another alarm control panel), the messages are played back after ground voltage (0V) is fed to the corresponding generator input, the 1st message on feeding the ground voltage to the IN1 input, the 2nd message on feeding the ground voltage to the IN2 input, etc. The inputs are dedicated to interface with the OC type outputs .

The VMG-16 generator enqueues up to 32 commands to play back voice messages.

The playback can be started manually. To do so, press the NEXT button to select the number of the message to be played back and press the PLAY button (the PLAY LED will go on).

Note: *If the VMG-16 generator is working in the variable length message mode and some messages are still to be recorded, an attempt to play back the non-existent messages will result in starting the first message.*

3.3 Volume level control

The volume level of the SPEAKER output can be controlled. For this purpose:

1. Press and hold down the NEXT button for approx. 2 seconds. The current gain level will be indicated on the LEDs (having blinked three times, the LEDs will be all the time on).
2. Press the PLAY button to increase the gain level, or press the REC button to decrease the gain level (control range from 1 to 8). The LEDs on the electronics board show the gain level.
3. Having set the required gain level, press the NEXT button to quit the volume level control function. The LEDs showing the gain level will go off (and the EA LED will go on).

Note: *If no operations are performed within 15 seconds of starting the volume control function, the generator will automatically return to the normal operating mode.*

4. Technical data

Maximum number of messages stored in memory	16
Rated power voltage	10.5V...14V DC
Average current consumption (no playback of messages).....	60mA
Maximum current consumption (message playback)	1.2A
Recommended impedance of loudspeaker connected to SPEAKER terminals	8Ω
Maximum power of speaker output	6W
Operating temperature range	5...45°C
Dimensions of electronics board	68x140 mm
Weight.....	90g

The latest EC declaration of conformity and product approval certificates
are available for downloading on website **www.satel.pl**



SATEL sp. z o.o.
ul. Schuberta 79
80-172 Gdańsk
POLAND
tel. + 48 58 320 94 00
info@satel.pl
www.satel.pl