

The CA-64 E zone expander is designed for operation in the intruder alarm systems. It can work in conjunction with the SATEL made CA-64, INTEGRA and VERSA alarm control panels. It enables the alarm system to be expanded by additional 8 zones. The expander zones can be programmed as NO, NC, EOL, 2EOL/NO or 2EOL/NC. The value of resistors in EOL and 2EOL configurations is programmable. The expander can support vibration and roller shutter motion detectors. This manual applies to the expander with electronics version 2.1 and firmware version 2.0 (or newer).

1. Description of electronics board

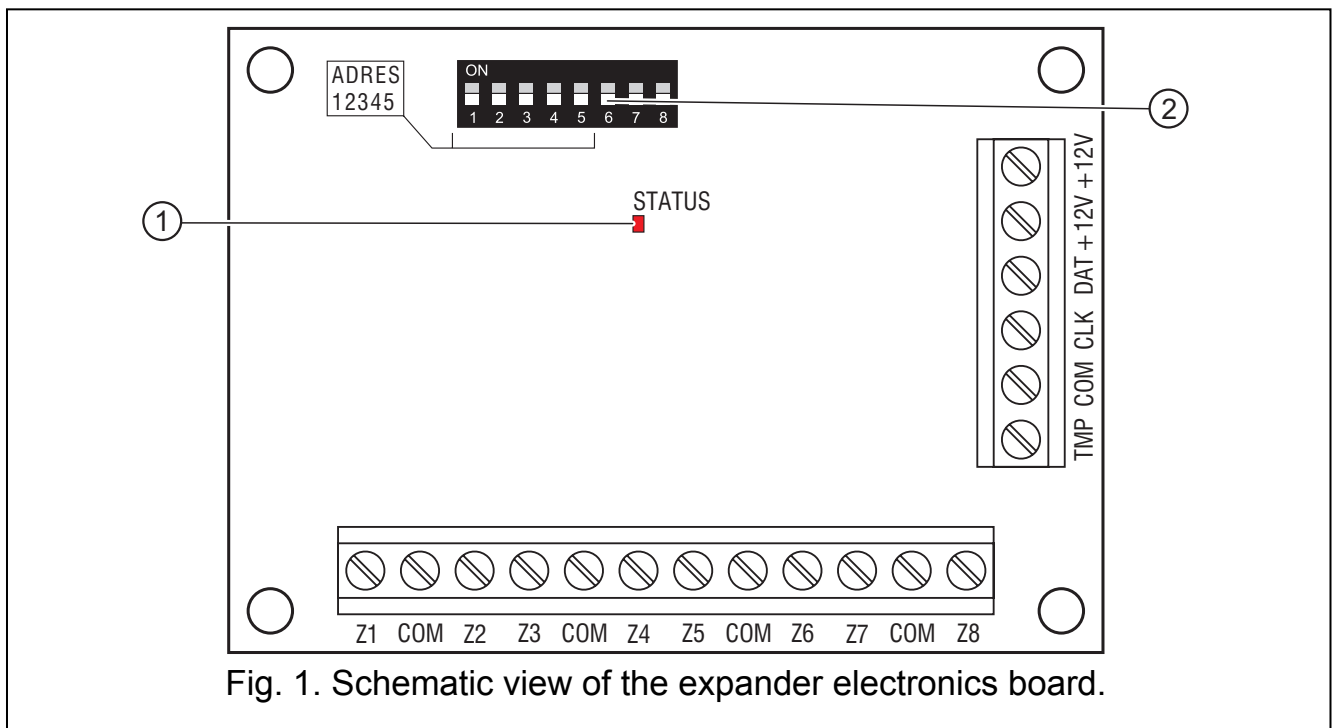

Fig. 1. Schematic view of the expander electronics board.

Explanations to Figure:

- 1 – **LED STATUS** to indicate the process of communication between control panel and expander:
 - LED is blinking – data exchange with the panel;
 - LED is lit – no communication with the control panel.
- 2 – **a set of DIP-switches** for setting individual address of the module and defining how the expander will be identified and, consequently, what functions will be available (see DIP-SWITCHES).

Description of the terminals:

- Z1...Z8** – zones.
- COM** – common ground.
- TMP** – tamper input (if no tamper contact is connected to this terminal, it should be shorted to common ground).

- CLK** - clock.
DTA - data.
+12V - expander power supply input (detectors power supply output).

1.1 DIP-switches

The DIP-switches from 1 to 5 are to be used for address setting. The address must be different from that of the other modules connected to the communication bus of alarm control panel. In case of interaction with the VERSA control panel, an address from the 12 (0Ch) to 14 (0Eh) range must be set. In order to determine the expander address, add up the values set on individual switches as shown in Table 1.

DIP-switch number	1	2	3	4	5
Numerical value (for switch in ON position)	1	2	4	8	16

Table 1.

The switches 6 and 7 must be set to OFF position.

Position of the switch 8 affects the way of expander identification and availability of some functions:

- **OFF** – the expander will be identified as **CA-64 E**. Support for the roller shutter motion and vibration detectors, as well as programming the resistor value in EOL and 2EOL configurations are not available.



The switch 8 must be in position OFF for the CA-64 control panel and for the INTEGRA panels with firmware up to and including version 1.04.

- **ON** – the expander will be identified as **CA-64 Ei** by the INTEGRA control panel with firmware version 1.05 or newer, as well as by the VERSA control panels (identification of the expander in the other panels will be impossible). Available are also support for roller shutter motion and vibration detectors and programming the resistor values in EOL and 2EOL configurations (make sure that a suitable resistor value is programmed).

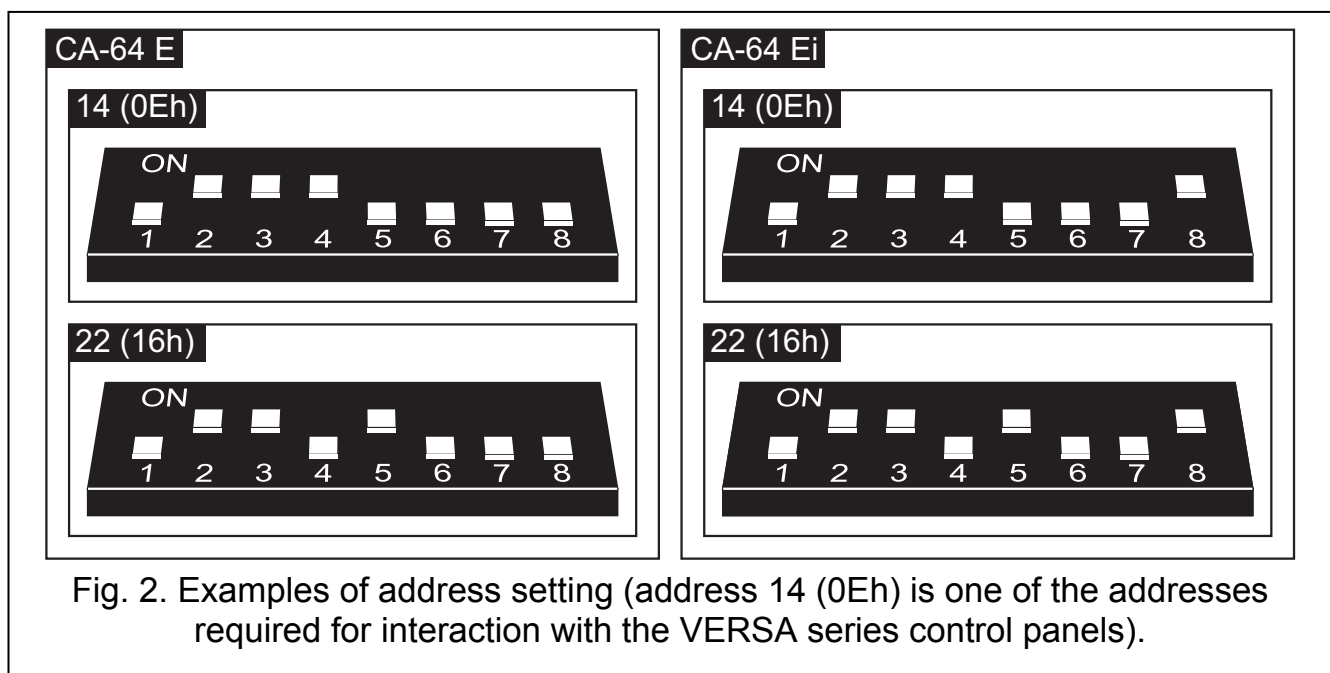

2. Installation and start-up



All connections should only be made when power supply of the alarm system is disconnected.

1. Fasten the expander board in its housing.
2. Using the DIP-switches, set the suitable expander address and define how it is to be identified.
3. Using cables, connect the CLK, DTA and COM terminals to the corresponding terminals of the control panel communication bus.
4. Connect the cables of housing tamper contact to the TMP and COM terminals (or short the TMP terminal to the COM terminal).
5. Connect the detector leads (for connection description refer to the alarm control panel installer manual).
6. Connect the module power supply cables to the +12V and COM terminals. Supply may be provided from the control panel mainboard, from an additional power supply unit or from an expander with power supply (see: installer manual for alarm control panel).
7. Turn on power supply of the alarm system.
8. Start the identification function in the control panel. When the identification is completed, the zones will be assigned respective numbers in the alarm system (zone numeration rules are described in the alarm control panel manual).

3. Specifications

Supply voltage	12 V DC \pm 15%
Number of programmable zones	8
Current consumption, standby.....	70 mA
Current consumption, maximum.....	70 mA
Dimensions of electronics board	57 x 80 mm
Environmental class according to EN50130-5.....	II
Operating temperature range	-10 °C...+55 °C
Weight.....	47 g

The latest EC declaration of conformity and product approval certificates are available for downloading on website www.satel.pl



SATEL sp. z o.o.
ul. Schuberta 79
80-172 Gdańsk
POLAND
tel. + 48 58 320 94 00
info@satel.pl
www.satel.eu