

The APMD-150 wireless dual motion detector is designed for operation as part of the ABAX two-way wireless system. It is supported by the ACU-100 controller with firmware in version 1.06 or later. Microwave (MW) sensor and double pyroelectric (PIR) element are applied in the detector design. The microwave sensor is triggered when the detector is in active state (see the ACU-100 controller user manual, wireless detectors section), after motion is registered by the infrared detector. The detector is characterized by high sensitivity and, at the same time, high immunity to interference and false alarms. Sensitivity of the microwave and infrared paths is set by radio, independently for each path. The remotely run test mode provides for separate testing of the microwave path and the infrared path. The temperature compensation feature makes possible operation within a broad temperature range.

Explanations for Fig. 1:

- 1 - CR123A 3 V lithium battery, ensuring operation for approx. 3-year period. The detector controls the battery status. When the voltage drops to 2.6 V, the "low battery" information is sent to the controller. The low battery signaling continues until the battery is replaced.
- 2 - microwave sensor.
- 3 - LED indicator. It lights red in the test mode only, indicating communication with the controller (during polling), violations (after motion is registered by the microwave or infrared path), and tampers.
- 4 - tamper contact, which responds to pull-off from back tamper unit.
- 5 - pyroelement.
- 6 - tamper contact, which responds to opening of the housing.
- 7 - antenna.
- 8 - fixing screw hole.
- 9 - screen.

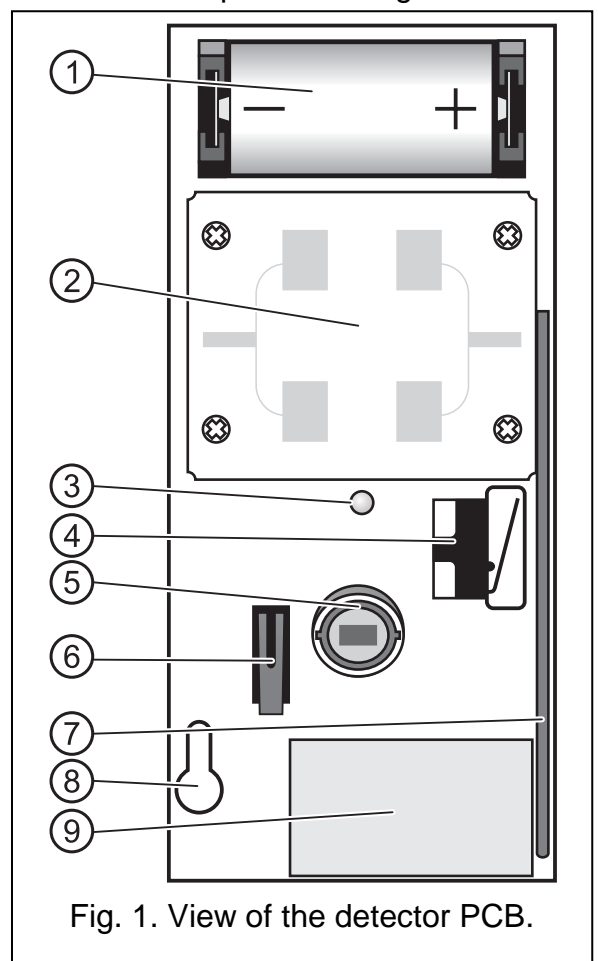

Fig. 1. View of the detector PCB.

1. Installation

The detector is designed for indoor installation. It can be secured to the wall, either directly or on the attached holder.



Before mounting the detector permanently, check the level of signal received from the detector by the ACU-100 controller and, if necessary, change the place of installation so that the location is optimal in terms of communication.

Install the battery inside the detector just before registering it in the controller. If unregistered or having no communication with the controller, the detector will consume more energy, which will reduce the battery life.

It is advisable to be particularly careful during installation so as not to foul up or damage the pyroelement.

Remember during installation not to direct the detector to heat sources and air-condition outlets, as well as objects exposed to strong insolation.

1. Open the housing.
2. Install the battery and add the detector to the wireless system (see the ACU-100 controller user manual). A label with 7-digit serial number that should be entered during registration of the detector in the system is provided on the screen on the electronics board.
3. Select the place where the detector is to be installed and attach it there temporarily.
4. Check the level of signal reaching the controller from the detector. If necessary, select another place for installation.
5. Having selected the place which ensures the optimum signal level, remove the electronics board from the housing.
6. Secure the back tamper unit to the holder screwed to the wall or directly to the wall (see Fig. 2).
7. Fasten the rear part of the housing to the back tamper unit (see Fig. 2).

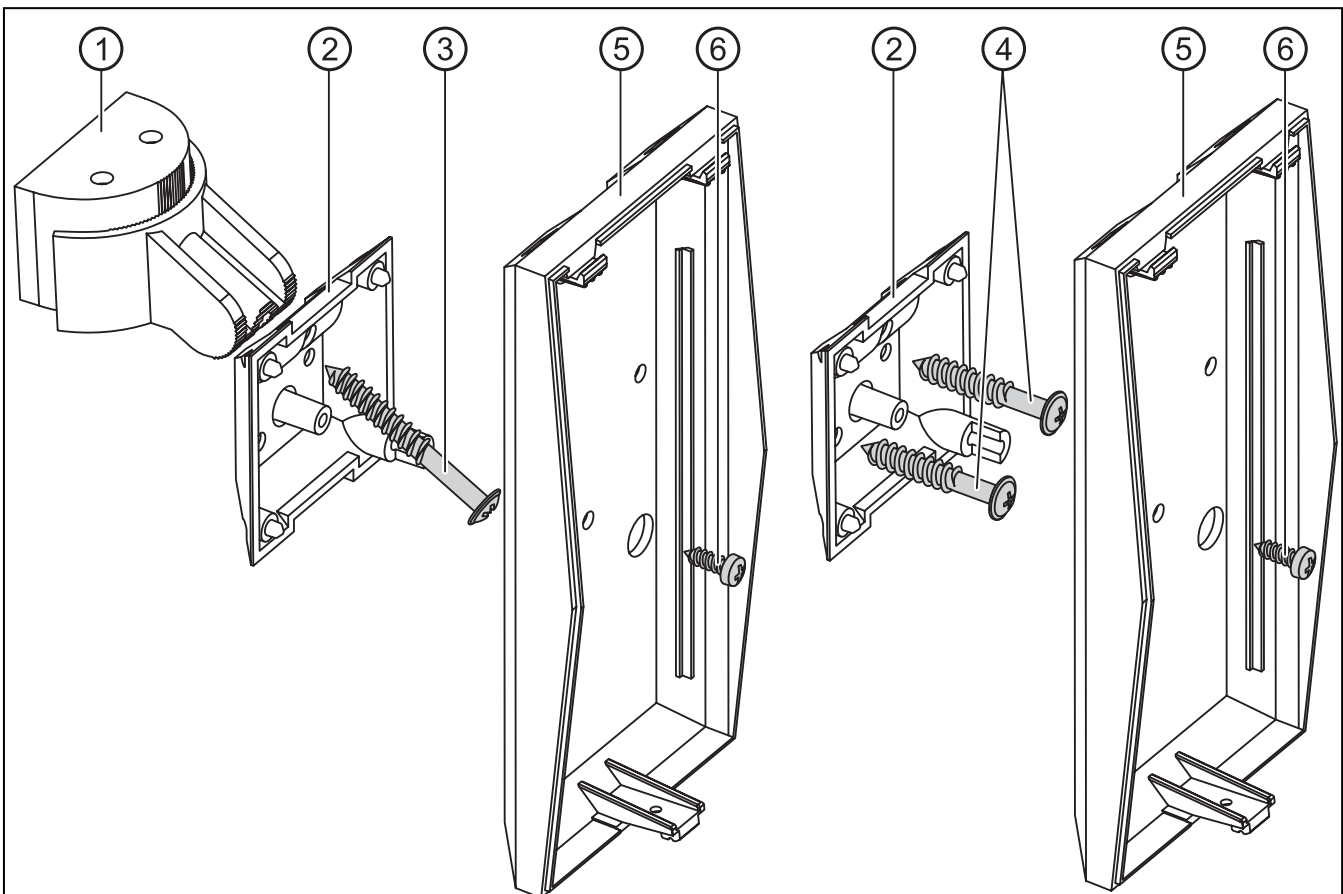
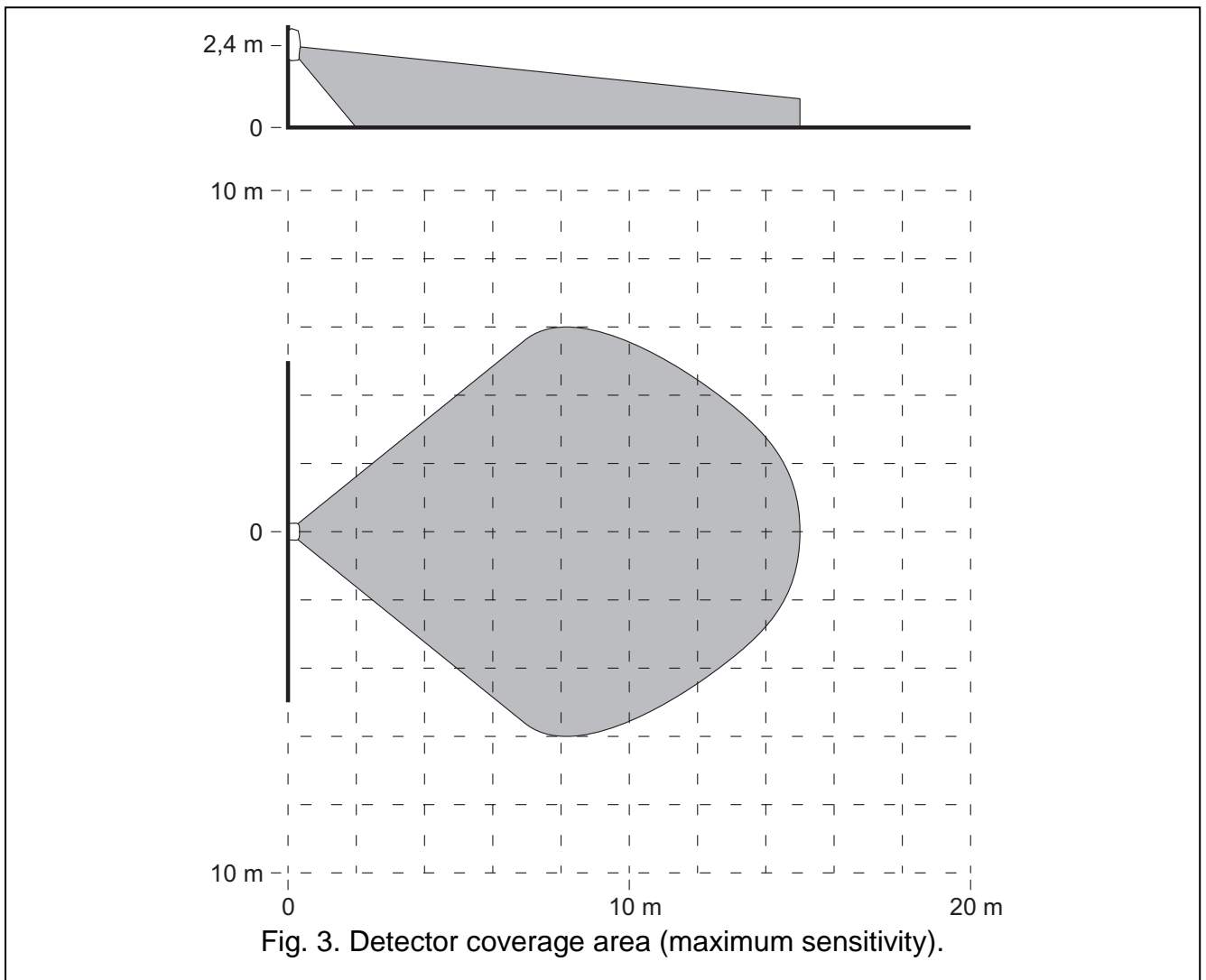

Fig. 2. Mounting the detector on holder and directly on wall. 1 – holder. 2 – back tamper unit. 3 – screw fixing the back tamper unit to the holder. 4 – screws fixing the back tamper unit to the wall. 5 – rear part of detector housing. 6 – screw fixing the rear part of detector housing to the back tamper unit.

8. Install the electronics board in the housing and close the housing.
9. Configure the detector as required. Information on configuration – see the ACU-100 controller user manual.

10. Launch remotely the test mode and check that movement within the monitored area will make the LED indicator light red. If necessary, change sensitivity of the microwave or infrared path.
11. Quit the test mode. The detector is is now ready for work.



2. Technical data

Working frequency band.....	868.0 MHz ÷ 868.6 MHz
Radio communication range	up to 400 m (in open area)
Power supply	CR123A lithium battery, 3 V
Battery life.....	approx. 3 years
Recommended installation height	2.4 m
Detectable motion speed	up to 3 m/s
Microwave head working speed.....	10.525 GHz
Environment class	II
Working temperature range	-10 °C...+55 °C
Housing dimensions	62 x 136 x 49 mm
Weight.....	137 g



Batteries in the battery-supplied wireless equipment should be replaced by qualified personnel. Incorrect replacement of the battery can pose an explosion hazard.

Always use the CR123A 3V lithium batteries.

The used batteries must not be discarded, but should be disposed of in accordance with the existing rules for environment protection.

DECLARATION OF CONFORMITY		CE 1471
<p>Product: APMD-150 – wireless dual technology motion detector for ABAX system</p>	<p>Manufacturer: SATEL spółka z o.o. ul. Schuberta 79 80-172 Gdańsk, POLSKA tel. (+48) 0-58 320-94-00 fax. (+48) 0-58 320-94-01</p>	
<p>Product description: Dual technology PIR+microwave motion detector intended for use with ABAX wireless alarm system components. Operating in the 868.0MHz – 868.6MHz frequency band. Supplied from a 3 V lithium cell. Device is intended for installation in intruder alarm systems.</p>		
<p>The product is in conformity with the following EU Directives: R&TTE 1999/5/EC</p>		
<p>The product meets the requirements of harmonized standards: ETSI EN 300 220-1: v.2.1.1; ETSI EN 300 220-2: v.2.1.1 ETSI EN 300 440-1: v.1.3.1; ETSI EN 300 440-3: v.1.1.2 ETSI EN 301 489-1: v.1.6.1; EN 301 489-3: v.1.4.1 EN60950-1:2004</p>		
<p>Notified entity participating in the conformity assessment: Identification No.: 1471</p>		
<p>Gdańsk, Polska 2007-11-26</p>	<p>Head of Test Laboratory:  Michał Konarski</p>	
<p>The latest EC declaration of conformity and product approval certificates are available for downloading on website www.satel.pl</p>		