

VOICE SYNTHESISER EXPANDER CA-64 SM



ca64sm_e 06/01

CA-64 voice synthesiser expander is a device designed to co-operate with CA-64 control panel. It has the capacity of storing 16 voice messages, each of which lasts for 15 seconds. These messages are used by CA-64 control panel in the process of using telephone notification of the alarm.

MODULE DESCRIPTION

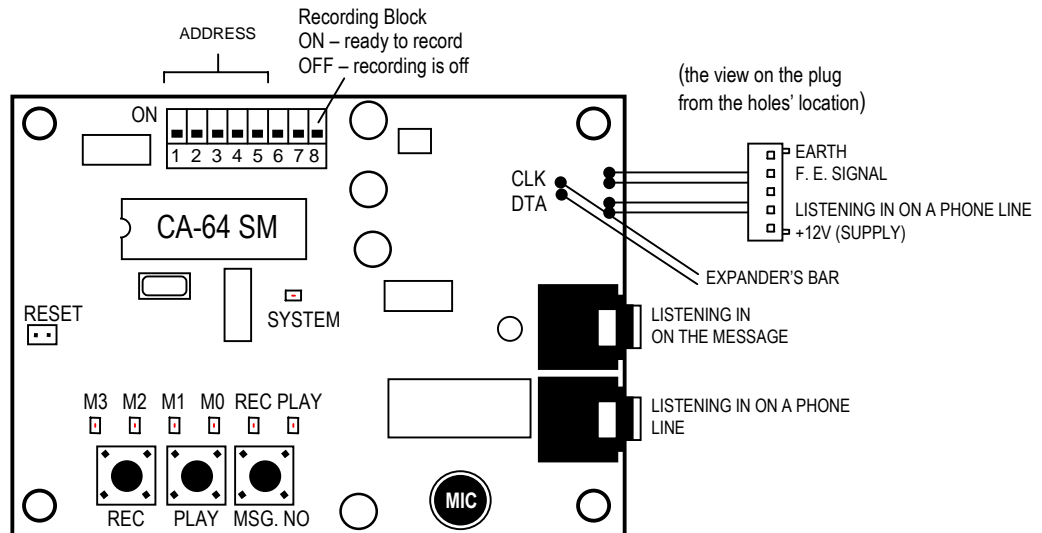

Table 1. Diagrammatic view of the expander's board.

The device is adjusted to be assembled in one casing along with CA-64 control panel main board; it does not have a separate TMP input of tampering circuit.

The module is to be connected to expander's bar and to synthesiser's socket on control panel main board. The conductors assembled with expander's board serve to connect the module. The expander is supplied with **constant voltage** through synthesiser's socket on control panel board.

There may be only one module of this type installed in the system.

The set of switches located on expander's board serves to select an individual address of the expander on the bar and also to block the function of messages recording.

Switches 1-5 serve to select the address, switches 6-7 are not used and the switch 8 is used to switch off the function of recording, which helps to protect already recorded messages against being deleted.

There are two **headphone sockets** on the board. The socket that is closer to assembly wires is used to play a recorded message and the other one is used to listen in on a telephone line. The possibility of listening in on a telephone line is very handy during starting the function of telephone notification; it enables the user to monitor the process of calling and the contents of messages.

Near headphone sockets there is a **microphone** installed, it serves to record messages.

The three **buttons** are used to operate synthesiser module by the user. The operation of the module by the control panel is limited to playing the messages recorded earlier.

RESET pins are used in the production process; they should not be short-circuited.

There are seven light-emitting diodes **LED** located on the board:

- **SYSTEM** diode indicates the communication process between the control panel and the expander. During a proper functioning of the module the diode flashes with varied frequency.
- **REC** diode is on when the message is being recorded.
- **PLAY** diode is on when the message is being played.
- **M0** and **M3** diodes indicate the number of the recorded or played message.

MODULE CONNECTING AND ACTIVATING

CAUTION: Before connecting the module, alarm system supply should be switched off.

1. Place expander's board on distance pins in control panel casing.
2. Connect wires marked CLK and DTA to expander bar's terminals (first bar: CK1, DT1, or second bar: CK2, DT2, - markings on the control panel main board). The wires that end with a pin should be connected to synthesiser's socket (SYNT1 or SYNT2) on the control panel main board.

CAUTION: After switching on control panel supply do not unclip synthesiser's pin from the main board socket with CLK and DTA wires connected, this may block the proper functioning of other expanders.

3. Using switches select expander's address and switch alarm system supply on (SYSTEM LED will emit a steady light).

We select the address using 1-5 switches. To identify expander's address we add up numbers that correspond to switches in **ON** position, according to this table:

Switch number	1	2	3	4	5
Numerical equivalent	1	2	4	8	16

Examples of addressing:

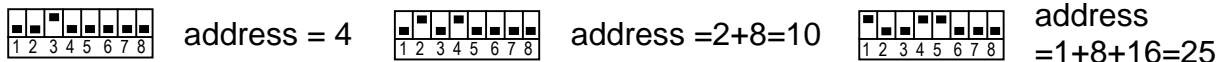

Five switches enable the user to address 32 expanders (numbers 0 - 31). Expander's addresses connected to one bar cannot be repeated, whereas the order of addressing is optional.

4. Start the communication between control panel and the computer through calling user's function "Downloading" (see: operating instructions on CA-64 control panel).
5. From LCD keypad call the function "expanders identification" (→Service Mode; →Structure; →Equipment) – SYSTEM diode should start flashing.

CAUTION: In the process of identification the control panel stores in module's memory a special number (16-bit), which is used to monitor module's presence in the system. Replacing the expander (even with the same address on the switches) without a new identification will activate the alarm (module's sabotage - verification error).

6. Using DLOAD64 software select the partition where sabotage alarms will be activated (there may be alarms in the case of a lockout or replacement of the module) and program the data on telephone notification.
7. Deactivate service mode and save data in FLASH memory.
8. Terminate the communication with a computer and save the system data in a separate file.

RECORDING AND LISTENING TO MESSAGES

Voice messages may be stored in module's memory both after its installation in the alarm system and before it. In order to perform an earlier recording of a message the +12V supply should be introduced into the module. Supply voltage is to be connected to +12V and EARTH contacts, using the plug and wires attached to expander's board (according specifications in table 1). Messages' memory is not deleted after supply is disconnected. The only way of deleting it is to record a new message in its place.

1. In order to record a message the switch 8 on expander's board should be switched **ON**.
2. Using **MSG. NO** switch choose the number of a message that is to be recorded or changed. Current message's number is displayed by means of LEDs: **M3**, **M2**, **M1** and **M0** according to the following table:

M3	M2	M1	M0	Message number
□	□	□	□	0
□	□	□	■	1
□	□	■	□	2
□	□	■	■	3
□	■	□	□	4
□	■	□	■	5
□	■	■	□	6
□	■	■	■	7
■	□	□	□	8
■	□	□	■	9
■	□	■	□	10
■	□	■	■	11
■	■	□	□	12
■	■	□	■	13
■	■	■	□	14
■	■	■	■	15

□ - diode is off
 ■ - diode emits light

This numeration is in accordance with message numbers programmed in control panel. The displayed number may be changed by clicking **MSG. NO** switch. Every click results in passing to the next message. Message numbers change in cycles and the next number after 15 is 0.

3. Press **REC** switch (REC diode will switch on) and dictate the message to the microphone. Recording lasts for 15 seconds without the possibility of shortening the message and is automatically terminated after 15 seconds (diode switches off). The module has the automatic recording level system.
4. In order to listen in on the recorded message plug headphones into **listening in on the message** socket. Pressing **PLAY** switch (PLAY diode will switch on) activates the process of listening in on the message, the number of which is displayed on M3-M0 diodes. Listening in on the message finishes after 15 seconds (diode switches off). Listening in on the message is always possible regardless of the position of switch 8.
5. After the messages have been recorded, switch 8 on module's board should be switched OFF in order to secure recordings against potential deletion.

TECHNICAL DATA

Number of stored messages 16
Duration of a single message 15 seconds
Supply voltage..... DC 10,5V...14V
Maximal power input 65mA
Size 57x80 mm

THE SET INCLUDES:

distance pins (used to install the module in the casing) 4 items.

P.P.U. SATEL s.c.
ul. Schuberta 79
80-172 Gdańsk; POLAND
tel. (58) 32 09 400; (39) 12 47 27
tech. depart. (58) 32 09 420; (604) 166 075
www.satel.pl
satel@satel.pl