

abox2

Smart plug
ASW-200

Firmware version 1.00

EN

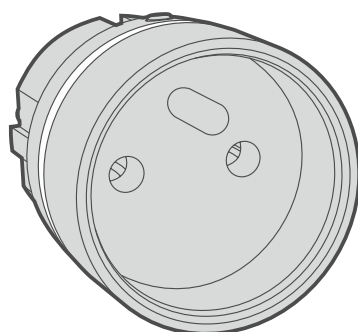

ASW-200 E

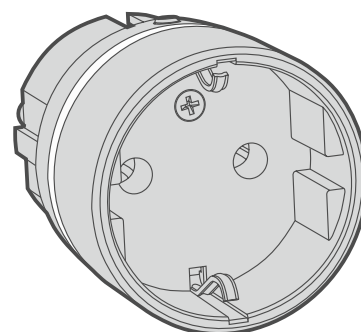

ASW-200 F

CE

asw-200_en 01/23

Satel  [®]

SATEL sp. z o.o. • ul. Budowlanych 66 • 80-298 Gdańsk • POLAND
tel. +48 58 320 94 00
www.satel.pl

IMPORTANT

Read this manual before connecting the device to mains supply.

Changes, modifications or repairs not authorized by the manufacturer shall void your rights under the warranty.

The rating plate of the device is located on the enclosure.



The device meets the requirements of the applicable EU directives.



The device is designed for indoor installation.



The device must not be disposed of with other municipal waste. It should be disposed of in accordance with the existing rules for environment protection (the device was placed on the market after 13 August 2005).



The device meets the technical regulations of the Eurasian Customs Union.

SATEL aims to continually improve the quality of its products, which may result in changes in their technical specifications and software. Current information about the changes being introduced is available on our website.

Please visit us at:
<https://support.satel.pl>

Hereby, SATEL sp. z o.o. declares that the radio equipment type ASW-200 is in compliance with Directive 2014/53/EU. The full text of the EU declaration of conformity is available at the following internet address: www.satel.pl/ce

In the EU, this radio equipment is only permitted to operate in the 868 MHz frequency band.

The following symbols may be used in this manual:



- note,



- caution.

CONTENTS

1.	Features	2
2.	Description.....	2
	Radio communication	3
	Operating modes	3
	Protection against overload and overheating.....	3
	LED indicator	4
3.	Start-up.....	4
4.	Configuring the LED indicator settings.....	5
	Starting configuration mode.....	5
	Configuring	5
5.	Specifications	5

The ASW-200 smart plug is used to remote control electrical appliances. The device is available in two versions:

- ASW-200 E with E type socket (EURO),
- ASW-200 F with F type socket (SCHUKO).

The plug is designed for operation within the ABAX 2 / ABAX two-way wireless system. It is supported by:

- ABAX 2:
 - ACU-220 / ACU-280 controller with firmware version 6.03 (or newer),
 - ARU-200 repeater.
- ABAX:
 - ACU-120 / ACU-270 controller (firmware version 5.04 or newer),
 - ARU-100 repeater (firmware version 2.02 or newer),
 - INTEGRA 128-WRL control panel (firmware version 1.19 or newer and firmware version of processor used to operate ABAX system 3.10 or newer).

1. Features

- Control of electrical appliances up to 2300 W.
- Relay switched on when the voltage is at the zero cross point.
- Encrypted two-way radio communication in the 868 MHz / 915 MHz frequency band (AES standard).
- Transmission channel diversity – 4 channels for automatic selection of the one that will enable transmission without interference with other signals in the 868 MHz / 915 MHz frequency band.
- Remote update of plug firmware.
- Remote configuration.
- LED indicator.
- Firmware protection against overload and overheating.

2. Description

The ASW-200 plug occupies one position on the list of wireless devices.

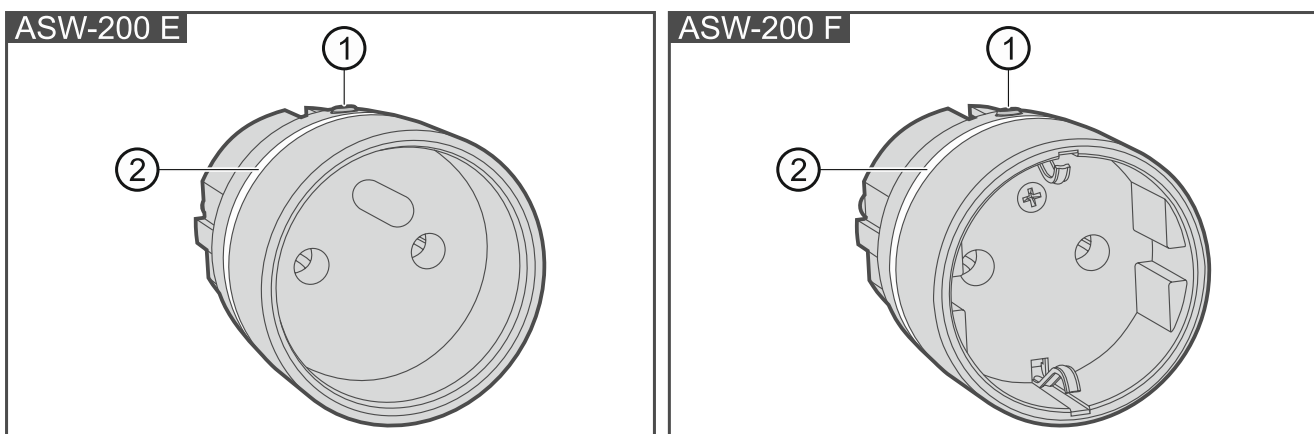

- ① button for manual control of the connected appliance (the button works differently depending on the selected operating mode of the plug – see “Operating modes”).

The button is also used to configure the LED indicator (see “Configuring the LED indicator settings”).

② LED indicator.

Radio communication

The ASW-200 plug connects to the controller / control panel at regular time intervals to provide information about its state (periodical communication). Additional communication takes place when:

- the plug button is pressed,
- control commands are being sent to the plug.

In the ABAX 2 system, information about the supply voltage of the plug and the current consumption of the appliance connected to the plug is also sent to the controller. The information is shown in the ABAX 2 Soft program. It can also be read from the controller using the Modbus RTU communication protocol.



For some devices, the power consumption is not measured.

Operating modes

You can select the operating mode when configuring the ASW-200 plug settings (see the controller / control panel manual).

mode 0– remote control only. Pressing the button does not control the appliance connected to the plug but information is sent to the controller whenever the button is pressed.

mode 1– remote or manual control. Press the button to turn ON / OFF the appliance connected to the plug. Information about the appliance state is sent to the controller / control panel.

mode 2– remote or manual control but with option to manually block the remote control. Press the button to turn ON / OFF the appliance connected to the plug. Press and hold the button for about 3 seconds to block / unblock the remote control. Information about the appliance state is sent to the controller / control panel.

Protection against overload and overheating

The plug has a firmware-based protection against overload or overheating.

Overload

If the current consumed by the appliance connected to the plug is greater than the rated current of the plug (10 A), the plug will automatically turn off the appliance. In order to restore the ability to control the appliance, disconnect the plug from the socket and plug it back in.



Do not use the plug to control appliances whose current consumption is greater than 10 A.

Overload is indicated by the LED indicator.

Overheating

If the temperature in the plug exceeds the maximum permissible value, the plug will automatically turn off the appliance. When the plug cools down, the appliance will automatically turn on and controlling the appliance will be possible.

Overheating is indicated by the LED indicator.

LED indicator

The LED indicates:

- ON with colors changing smoothly for 2 seconds – warm-up after the plug has been connected to 230 VAC socket,
- ON – when the appliance connected to the plug is turned on (one color is selected or colors change smoothly depending on the current consumed by the appliance connected to the plug, where: blue – minimum value, green – maximum value for appliances up to 300 W, red – maximum value for appliances up to 2300 W),
- 3 short red flashes – remote control was blocked / unblocked by pressing the button on the enclosure (mode 2),
- 1 short red flash – appliance connected to the plug was turned on by pressing the button when remote control is blocked (mode 2),
- 2 short red flashes – appliance connected to the plug was turned off by pressing the button when remote control is blocked (mode 2),
- flashing yellow – overload (flashing for the entire duration of the trouble),
- flashing red – overheating (flashing for the entire duration of the trouble).

In the factory default settings, the LED indicator is turned off, i.e. it only indicates warm-up and troubles (overload and overheating). You can turn it on / off when configuring the LED indicator settings (see “Configuring the LED indicator settings”). The LED indicator is also used in the LED indicator configuration mode.

3. Start-up

The ASW-200 plug should be used indoors, in spaces with normal air humidity. When in use, the plug must be located within the radio range of the controller / control panel. Thick walls, metal partitions, etc. will reduce the range of the radio signal. Use the ARF-200 tester to check the level of radio signal. Place the tester next to the 230 VAC socket. If the radio signal level indicated by the tester is higher than 40%, the plug can be used there.

1. Connect the plug to the selected 230 VAC socket.
2. Add the ASW-200 controller to the wireless system and configure its settings (see ABAX / ABAX 2 controller manual or INTEGRA 128-WRL control panel manual and “Configuring the LED indicator settings”). The sticker with the serial number required to register the plug in the system can be found on its enclosure.



In the ABAX system, the plug is identified as ASW-100.

In the VERSA alarm system, you can add and configure the ASW-200 plug by using the DLOADX program.

Simultaneous operation of the ASW-200 plug by the ABAX 2 and ABAX controller / INTEGRA 128-WRL alarm control panel is not possible.

3. Check if the plug works properly.



If you need to perform any service or maintenance work on the appliance, disconnect it from the ASW-200 plug first. Leaving the appliance connected when the plug is inserted into the 230 VAC socket causes a risk of electric shock.

4. Configuring the LED indicator settings

You can configure the LED indicator by using the button on the plug enclosure. The LED indicator can:

- indicate the current consumption by the appliance when it is turned on:
 - the indicator color changes smoothly from blue to green – current consumption by appliances up to 300 W (current consumption up to 1.3 A), where: blue – minimum current consumption, green – maximum current consumption,
 - the indicator color changes smoothly from blue to red – current consumption by appliances up to 2300 W (current consumption up to 10 A), where: blue – minimum current consumption, red – maximum current consumption,
- emit steady light when the appliance is turned on (you can select the color),
- be turned off.

Starting configuration mode

Press and hold the button on the plug enclosure. Then connect the plug to the 230 VAC socket and release the button after 3 seconds. When the configuration mode is started, the LED indicator will turn ON, changing its color smoothly from blue to red (see “Configuring”).

Configuring

1. Keep pressing the button on the plug enclosure to select the indication mode. The LED indicator shows which indication mode is currently selected:
 - smoothly changes color from blue to red – the indicator will show the current consumption by the appliance,
 - flashing one color – the indicator will emit steady light when the appliance is turned on (7 colors are available),
 - OFF – the indicator will be turned off (only warm-up and troubles will be indicated).
2. Wait about 6 seconds. The selected indication mode is saved. The LED indicator configuration mode is terminated.

5. Specifications

Operating frequency band	868.0 MHz ÷ 868.6 MHz / 915 MHz – 928 MHz
Radio communication range (in open area)	
ABAX 2.....	up to 1000 m
ABAX.....	up to 500 m
Supply voltage	230 VAC, 50-60 Hz
Standby power consumption.....	1 W
Rated current (resistive load).....	10 A



For load other than resistive, it should not exceed 3 A at 230 VAC. The power factor (cosφ) must be equal to or greater than 0.4.

Complied with standards.....	EN 50130-4, EN 50130-5
Environmental class according to EN50130-5	II
Operating temperature range.....	-10°C...+55°C
Maximum humidity	93±3%

Dimensions:

ASW-200 E ø45 x 67 mm

ASW-200 F ø45 x 70 mm

Weight:

ASW-200 E 60 g

ASW-200 F 61 g