

PRT-LT Series
EM 125 kHz Access Readers

Firmware 1.25

Rev. D



This document refers to the following products:

- *PRT12LT*
- *PRT12LT-BK*
- *PRT32LT*
- *PRT42LT*
- *PRT42LT-BK*
- *PRT62LT*
- *PRT64LT*
- *PRT66LT*

Installation and Programming Guide

1 . I M P O R T A N T N O T E S

The PRT-LT reader can be configured for several data output format however the factory shipped new unit is pre-configured for **RACS address ID=0**. If required reader can be reconfigured manually using Memory Reset procedure. Comparing with PRT-EM series access terminals the PRT-LT series readers doesn't support standalone operating mode.

Note: If after power up the LED SYSTEM  is lit and accompanied with repeated sound it means that contents of reader's memory is corrupted. In this case reader must be initialized and configured from the scratch.

1.1. COMPATIBILITY RULES

Always check the firmware and hardware version for which manual is dedicated. Using wrong version of manual may cause that device will not behave as described in document.

1.2. ABOUT THIS MANUAL

This manual is dedicated for all versions of PRT-LT readers: with keypad and without keypad. No matter if the PRT-LT readers have built-in keypad or not they represents the same logical functionality. The only difference between various types of PRT-LT readers is limited to their mechanical construction, environment in which they can be installed and keypad which exist in some PRT-LT units.

2 . G E N E R A L D E S C R I P T I O N

The PRT-LT readers have been designed for use in access control installations to enable user identification via EM 125 KHz (and compatible) proximity cards and/or PIN-s. The PRT-LT reader works as a slave unit serving a sole purpose of reading cards/PIN-s then providing subsequent transmission of such collected data to host ACU for further processing. Reader offers several data transmission formats including popular Wiegand/Magstripe data protocols.

2.1. FEATURES

2.1.1. General

- EM 125 KHz proximity cards (EM4100/4102 compatible)
- Up to 10..15 cm reading range (*)
- Outdoor and indoor installations (*)
- 26/32/32 reversed/34/42/66 bit Wiegand data formats
- Magstripe data format (ABA Track II emulation)
- RACS data output format (Roger format)
- Various options for transmission of PIN-s and keys
- LED control input
- BUZZER control input
- Tamper switch
- CE approval

(*) – depends on individual reader type

2.2. PROXIMITY CARDS

The PRT-LT was designed for EM 125 KHz proximity cards compatible with EM 4100/4102 transponders. Reader returns card number without check sum bits. Card number is transmitted starting from the LSB to MSB and if required (it depends on the data output format selected for the given reader) can be supplemented with leading zeros or reduced on the MSB positions.

2.3. FUNCTION KEYS

Some of the PRT-LT readers are equipped with two (e.g. PRT12LT) or one (PRT42LT and PRT42LT-BK) function keys: [F1]- marked with door bell icon and [F2] – marked with the light bulb icon. The function of each function keys depends on the reader's operation mode.

When in **RACS Mode**, pressing function key will cause transmission of the relevant code to the host controller which can further take adequate action (e.g. trigger door bell, light etc.). The host's reaction for function key always depends on its configuration.

When in **Wiegand** or **Magstripe** modes, pressing the F1/F2 causes following codes send over the output lines:

For Wiegand:

- F1=C hex
- F2=D hex

For Magstripe:

- F1=FF FF FF FF BC hex (1099511627708 dec)
- F2=FF FF FF FF BD hex (1099511627709 dec)

2.4. OPERATING MODES

The PRT-LT offers following data transmission formats:

- Wiegand 26bit
- Wiegand 32bit, normal mode (from MSB to LSB)
- Wiegand 32bit, reverse order (from LSB to MSB)
- Wiegand 34bit
- Wiegand 42bit
- Wiegand 66bit
- Magstripe (ABA Track II emulation, also called Clock & Data)
- RACS (for communication with PR series of controllers from Roger)

Wiegand Formats

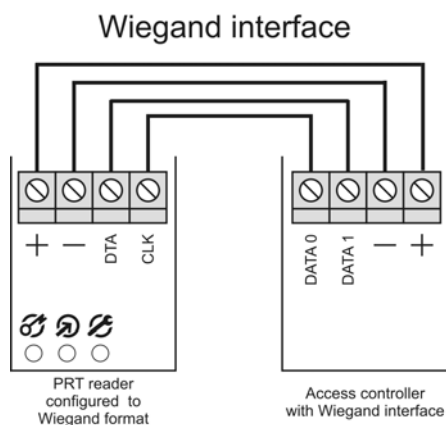

When employing **Wiegand** transmission format, data is sent to the host using sequences of pulses transmitted over CLK and DTA lines (which in this case are called DATA1 and DATA0). Depending on the selected version of the transmission format, the reader can send 26, 32, 34, 42 or 66 bits to the host.

Note: For card codes which require more bits than the number of bits available in the selected data transmission format, reader omits the most significant bits (MSB-s) of the card code. As a result transmission from a reader is not the same as full card code.

In **Wiegand** format, a dual color LED STATUS lights steady in red, LED OPEN is controlled by IN1 while buzzer is controlled by IN2. Both inputs (IN1 and IN2) are triggered by connecting them to supply minus. In addition, whenever card is read or PIN is entered reader activates momentary LED SYSTEM and buzzer.

Magstripe Formats

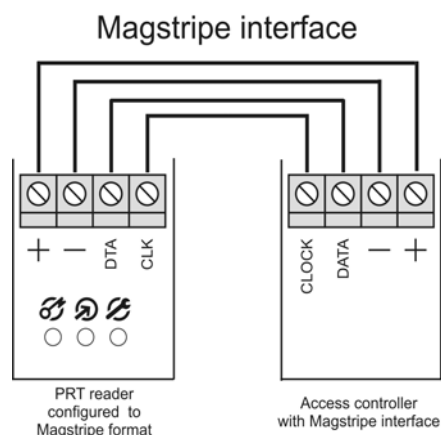

When employing **Magstripe** transmission format, data is transferred to the host using electric signal waves transmitted over the CLK and DTA lines. In **Magstripe** format a dual color LED STATUS lights steady in red, LED OPEN is controlled by IN1 while buzzer is controlled by IN2. Both inputs (IN1 and IN2) are triggered by supply minus. In addition, whenever card is read or PIN is entered reader activates momentary LED SYSTEM and buzzer. Card code is always transmitted as a whole number

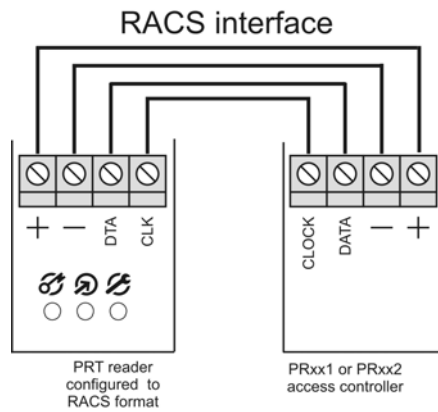

RACS Format

When employing **RACS** format, the PRT-EM unit communicates with the host via CLK/DTA lines. Unlike in the **Wiegand** and **Magstripe** formats, the PRT-LT unit using **RACS** format requires an individual address (ID=0...3) to be set during configuration of the reader. With **RACS** format, communications between the reader and the host is bilateral, this allows controller to monitor communication. The reader's LED-s and the buzzer are controlled by the host unit, unless the reader has lost communication with the host.

Note: When all LED-s are flashing it indicates that reader lost communication with the host unit.

When in **RACS** mode triggering of the IN1 disables reading of the card and keypad. This input can be used for temporary disabling of the reader. The IN2 is not used in **RACS** mode.

3 . C O N F I G U R I N G T H E R E A D E R

3.1. MEMORY RESET

The **Memory Reset** erases entire contents of the reader's memory and enables for programming of the reader's operating mode.

Memory Reset procedure:

1. Power down the unit
2. Remove all connections from CLK and IN1 lines
3. Connect CLK to IN1
4. Restore power, reader will generate continuous beep
5. While LED OPEN (green) is flashing and accompanied with continues sound disconnect CLK from IN1, after this step reader's memory is erased and filled with default values
6. Wait till LED SYSTEM will start flashing
7. Enter three digits which will configure the reader for the required operating mode, (with every entered digit reader generates two beeps). Optionally, if the programmed reader is not equipped with the keypad emulate these three digits using method of multiple card reading (see details in section below)
8. Once the previous step is completed reader automatically ends the **Memory Reset** and enters normal operation

3.2. PROGRAMMING THE PRT-LT READERS WITHOUT KEYPAD

Although some PRT-LT readers are not equipped with keypad still they can be programmed manually according to the same programming procedures as readers with keypad. The difference in programming is so that instead of pressing certain keys (like you normally do when programming readers with keypad) you must emulate keys by multiple readings of the any proximity card (this card will be latter called *Programming Card*). So called *Programming Card* can be any proximity card – once you read it during programming continue to use it later during entire cycle of programming. Of course, next time you will perform programming again you can use the same or another prox. card as *Programming Card*. For example in order to emulate key [9] you must read the designated *Programming Card* 9-times (simply present it to the reader and take it back 9-times) and then wait approx. 3 seconds for the reader to generate a confirmation signal (two beeps) which means that series of card readings were accepted as an equivalent of a single key press and the reader is waiting for the next step of the programming procedure.

Key	Emulation Method
[1]	Read <i>Programming Card</i> 1-time
[2]	Read <i>Programming Card</i> 2-times
[3]	Read <i>Programming Card</i> 3-times
[4]	Read <i>Programming Card</i> 4-times
[5]	Read <i>Programming Card</i> 5-times
[6]	Read <i>Programming Card</i> 6-times
[7]	Read <i>Programming Card</i> 7-times
[8]	Read <i>Programming Card</i> 8-times
[9]	Read <i>Programming Card</i> 9-times
[0]	Read <i>Programming Card</i> 10-times
[*]	Read <i>Programming Card</i> 11-times
[#]	Read <i>Programming Card</i> 12-times
Note: Each time you complete the sequence of multiple readings of the <i>Programming Card</i> wait for the reader to generate confirmation signal (two beeps) which will confirm that reader has accepted series of card readings as the emulation of a single key press.	

Example: In order to emulate following programming sequence [][1][0][ID][#] where ID=113 do following:*

1. [*]: Read 11-times your *Programming Card* and then wait for two beeps
2. [1]: Read 1-time your *Programming Card* and then wait for two beeps
3. [0]: Read 10-times your *Programming Card* and then wait for two beeps
4. [1]: Read 1-time your *Programming Card* and then wait for two beeps
5. [1]: Read 1-time your *Programming Card* and then wait for two beeps
6. [3]: Read 3-times your *Programming Card* and then wait for two beeps
7. [#]: Read 12-times your *Programming Card* and then wait for two beeps

3.2.1. Reader Operating Modes

The factory new reader is pre-configured for **RACS address ID=0** however whenever required it can be changed using Memory Reset procedure. There are following operation modes available for the PRT-LT series reader:

Code	Operating mode	Description
000	Online mode: RACS address ID=0	Reader operates as a slave unit connected to the host controller that requires RACS data transmission format.
001	Online mode: RACS address ID=1	
002	Online mode: RACS address ID=2	
003	Online mode: RACS address ID=3	
020	Online mode: Magstripe	Reader operates as a slave unit connected to the host controller which requires Magstripe data transmission format, keys are not transmitted.
021	Online mode: Magstripe UNITEK	Reader operates as a slave unit connected to a host controller which requires Magstripe data transmission, keys transmitted as single digits, format is compatible with specification of UNITEK controllers (with transmission of PIN-s).
10x	Online mode: 26 bit Wiegand	Reader operates as a slave unit connected to the host controller that requires relevant Wiegand data transmission format.
11x	Online mode: 34 bit Wiegand	
12x	Online mode: 42 bit Wiegand	
13x	Online mode: 66 bit Wiegand	
14x	Online mode: 32 bit Wiegand (no parity)	
15x	Online mode: 32 bit Wiegand reverse (from LSB to MSB, no parity)	
<p>Note: For Wiegand data formats the second digit of the operating mode code (marked as X) specifies the method which reader employs when transmitting PIN-s or keys. For details regarding methods of PIN transmission refer to table below.</p>		

PIN/keys transmission options		
X	Description	Details
X=0	1-10 digits long PIN, transmitted in BCD format	Each key pressed is buffered in reader's memory; with a press of a [#] key reader transmits entire PIN code. The PIN code is transmitted as a BCD coded number.
X=1	1-12 digits PIN, transmitted in binary format	Each key pressed is buffered in reader's memory; with a press of a [#] key reader transmits entire PIN code. The PIN code is transmitted as a binary number.
X=2	Each key pressed is transmitted separately as 4-bit number plus 2 control bits	Each key pressed is immediately transmitted to the host controller as a sequence of 6 bits (EXXXP) where XXXX represents the code of the pressed key supplemented by two control bits (E and P). The E represents the even bit calculated from the first half of a transmitted code where P represents the parity of a second half of the bit stream. This format is compatible with HID 5355 series readers, option: <i>With Parity</i> . Key coding as in Table B (below).
X=3	Each key pressed is transmitted separately as 4-bit number	Each key pressed is immediately transmitted to the host controller as a sequence of 4 bits (XXXX) which represent the code of the pressed key, no control bits added. This format is compatible with HID 5355 series readers, option: <i>Without Parity</i> . Key coding as in Table B (below).
X=4	Each key pressed is transmitted separately as 8-bit number with parity	Each key pressed is immediately transmitted to the host controller as a sequence of 10 bits (EXXXXXXXXXP) where XXXXXXXX represents the code of the pressed key supplemented by two control bits (E and P). The E represents the even bit calculated from the first half of a transmitted code where P represents the parity of a second half of the bit stream. Key coding as in Table A (below).
X=5	Each key pressed is transmitted separately as a 8-bit number without parity bits	Each key pressed is immediately transmitted to the host controller as a sequence of 8 bits (XXXXXXXX) where XXXXXXXX represents the code of the pressed key supplemented by two control bits (E and P). The E represents the even bit calculated from the first half of a transmitted code where P represents the parity of a second half of the bit stream. Key coding as in Table A (below).
X=6	1-6 keys long PIN transmitted as Wiegand 26 bit stream with control bits	1-6 keys long PIN, each key represented by 4-bit long codes (key codes according to table B). Reader sends data after six keys are pressed or earlier when # key is pressed. Reader wait max ca. 15 seconds for each key press. Key's buffer is cleared if no keys have not been entered within ca. 15 seconds. Examples: Keys entered "1234#" – code transmitted "001234" Keys entered "123456" – code transmitted "123456"
X=7	1-4 keys long PIN transmitted as Wiegand 32 bit stream without control bits	1-4 keys long PIN, each key represented by 8-bit long codes (key codes according to table A). Reader sends data after four keys are pressed or earlier when # key is pressed. Reader wait max ca. 15 seconds for each key press. Key's buffer is cleared if no keys have not been entered within ca. 15 seconds. Examples: Keys entered "123#" – code transmitted "0123" Keys entered "123456" – code transmitted "123456"

Table A: 8-bit key coding		
Key	HEX	BIN
0	F0	11110000
1	E1	11100001
2	D2	11010010
3	C3	11000011
4	B4	10110100
5	A5	10100101
6	96	10010110
7	87	10000111
8	78	01111000
9	69	01101001
*	5A	01011010
#	4B	01001011
F1	3C	00111100
F2	2D	00101101

Table B: 4-bit key coding		
Key	ASCI	BIN
0	0	0000
1	1	0001
2	2	0010
3	3	0011
4	4	0100
5	5	0101
6	6	0110
7	7	0111
8	8	1000
9	9	1001
*	A	1010
#	B	1011

3.3. INSTALLATION GUIDELINES

- Reader should be installed in such a way to assure physical access to the connection cable
- A new factory delivered unit is configured for **RACS address ID=0** however data output format can be changed whenever required using **Memory Reset** procedure
- The PRT-LT reader should be mounted near the supervised door on a vertical piece of supporting structure
- Disconnect power supply before making any electrical connections
- Be aware that when installing the reader directly on the metal type surface card reading distance will deteriorate
- For installations on a metal surface you can place a non-metallic 10 mm thick spacer (a plastic/plaster plate etc.) between the reader and the supporting structure
- For installations with two readers to be mounted on the opposite sides of the same wall and aligned along the same geometrical axis, place a metal plate between them and make sure none of two readers has direct contact with it (allow min. 10 mm space)
- For best results mount the proximity readers at least 0.5 m apart
- With its relatively weak electromagnetic field generation, reader should not cause any harmful interference to operation of other equipment. However, its card reading performance can be affected by other interference generating devices, esp. radio waves emitting equipment or CRT computer monitors
- If card reading performance of the reader deteriorates (e.g. reduced reading range or incorrect readings) consider reinstallation in a new location.

Connection terminal assignments		
Wire Color	Label	Function
Green	CLK	DATA 0 line for Wiegand, CLOCK for Magstripe and RACS
Brown	DTA	DATA 1 line for Wiegand, DATA for Magstripe and RACS
Yellow	IN1	Input line; in Wiegand and Magstripe formats this line controls LED OPEN  . Line is active when shorted to ground
Pink	IN2	Input line; in Wiegand and Magstripe formats this line controls internal sunder of the reader. Line is active when shorted to ground
Red	+12V	Supply input plus
Blue	GND	Supply input minus
Grey	TAMP	Tamper switch contacts, normally closed, isolated, IP67, 24V/50mA. Contact became open when unit is detached from the place of installation or upper part of enclosure is open
White		

Note: For screw terminals assignments see additional drawings later in this document.

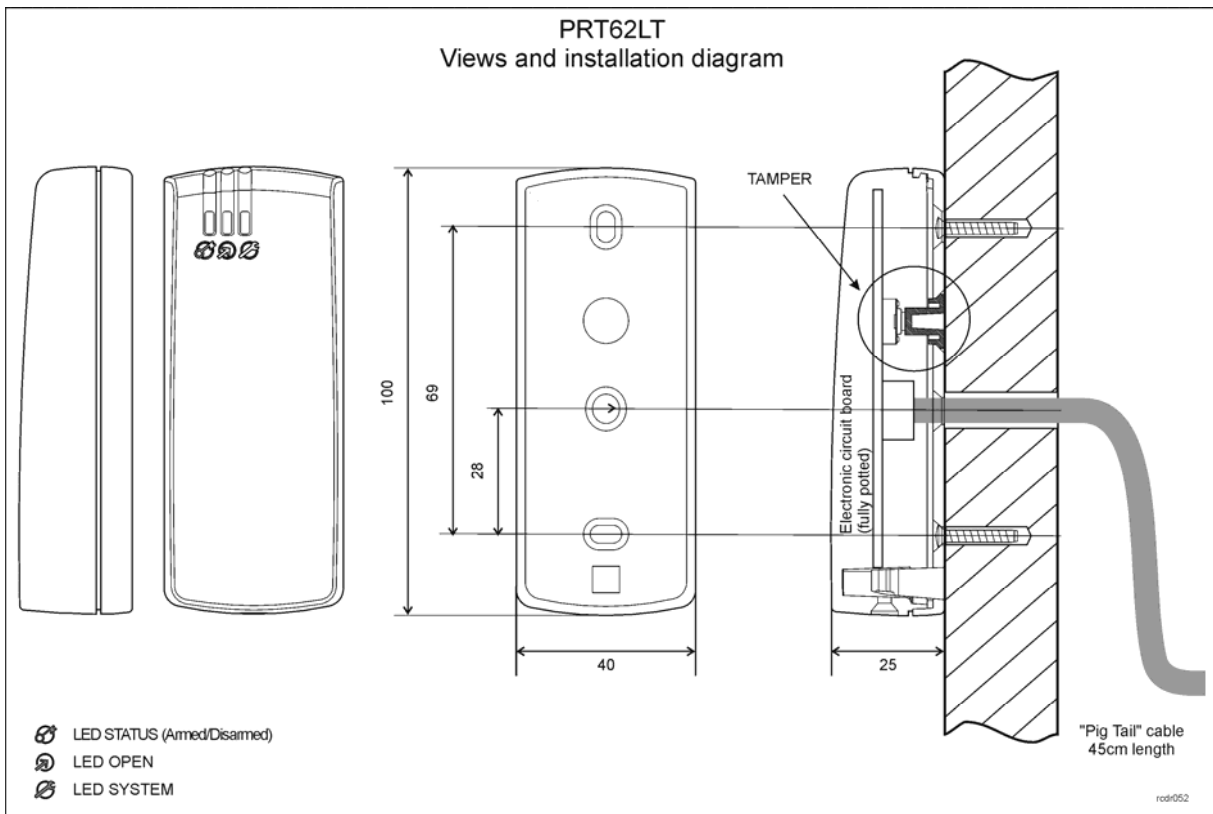
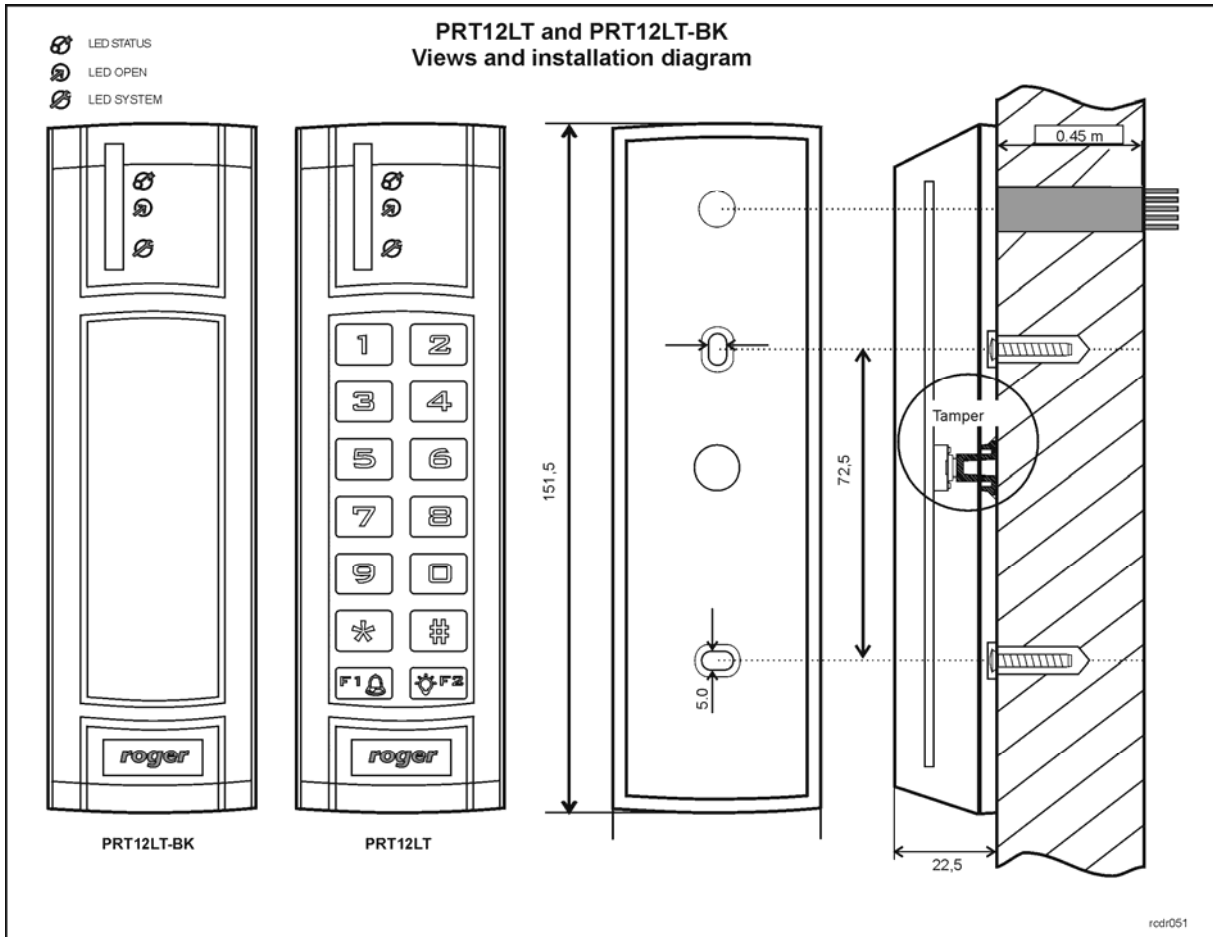

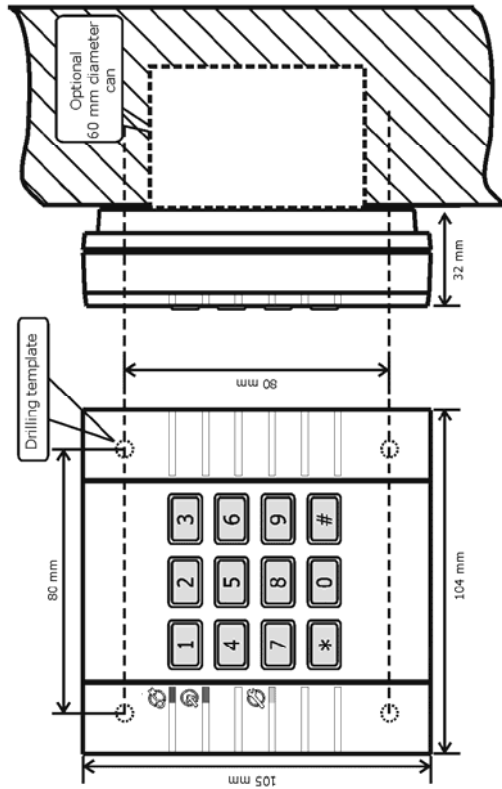

The view and installation diagram of PRT32LT terminal

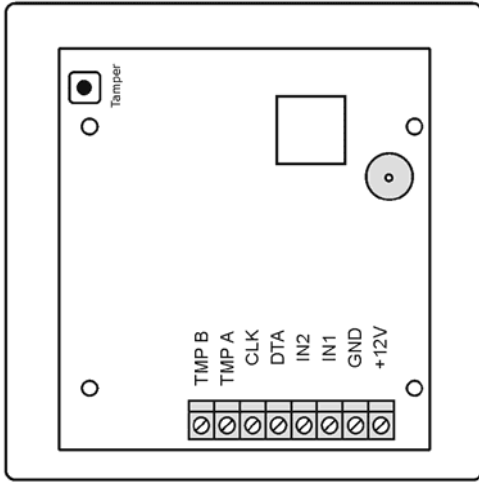

Location of connection terminals

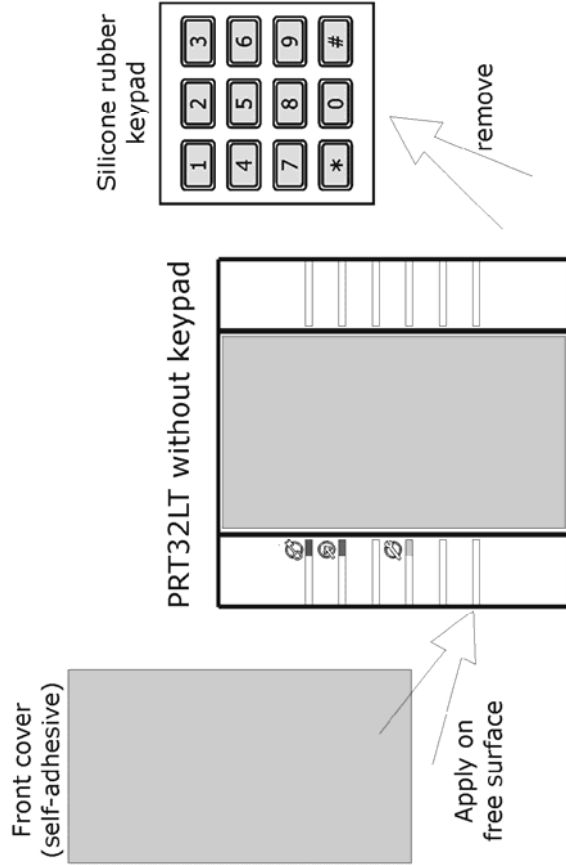

If required keypad can be removed and replaced with plastic self-adhesive front panel

PRT32LT

rcdr058

PRT42LT and PRT42LT-BK Views and installation diagram

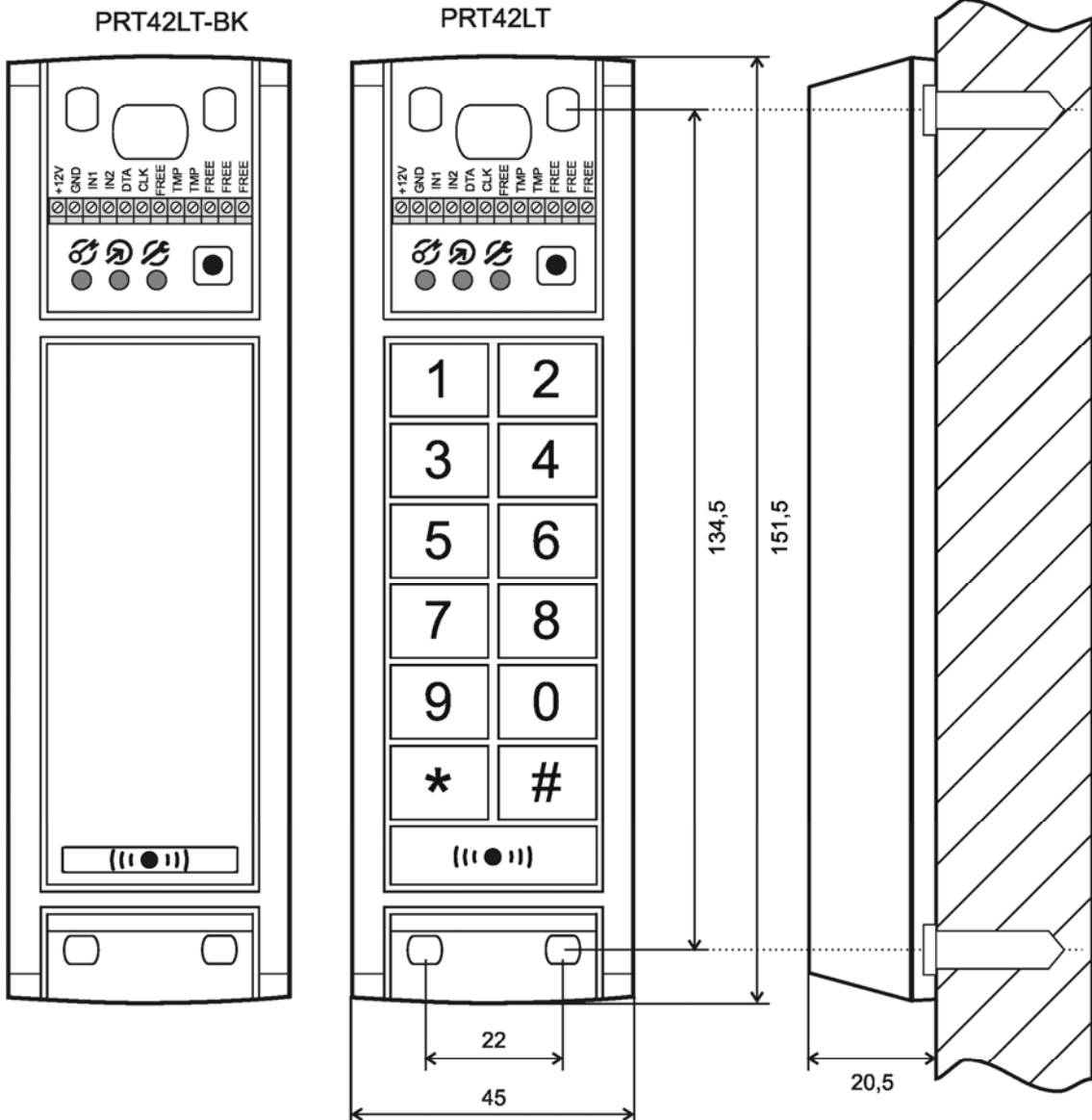

(((●))) F1 Function key (Door Bell)

- LED STATUS (Armed/Disarmed)
- LED OPEN
- LED SYSTEM

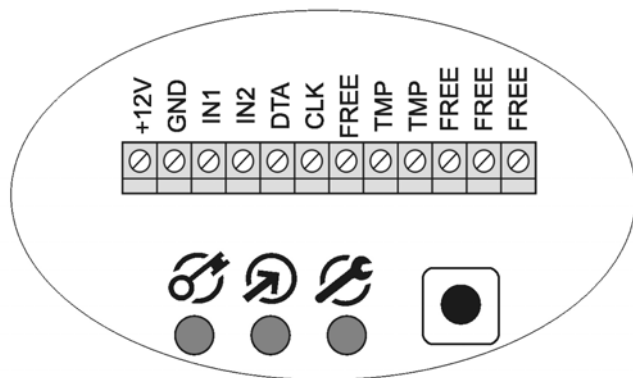

rodr059

PRT64LT

Views and installation diagram

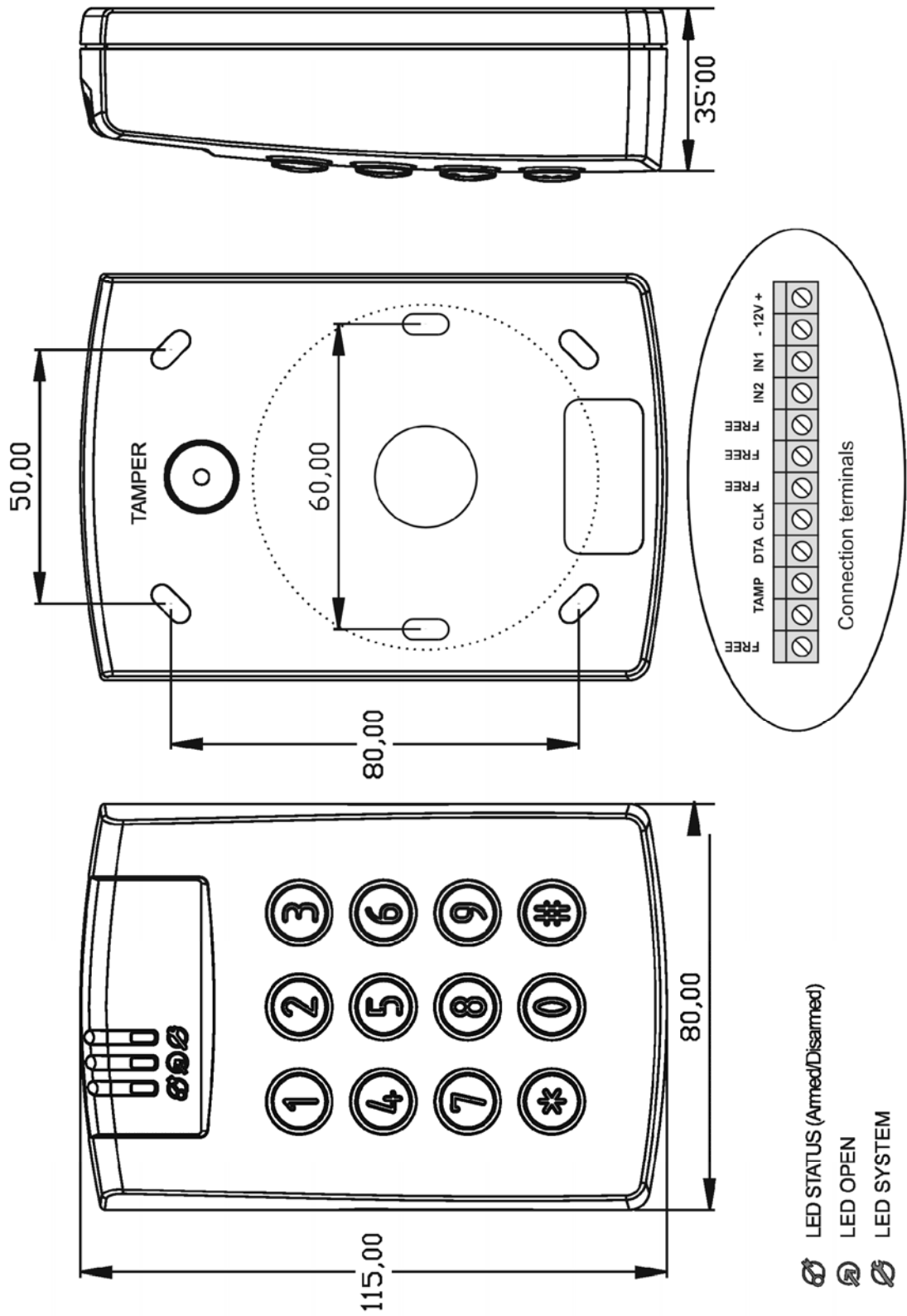



rcdr053

PRT66LT

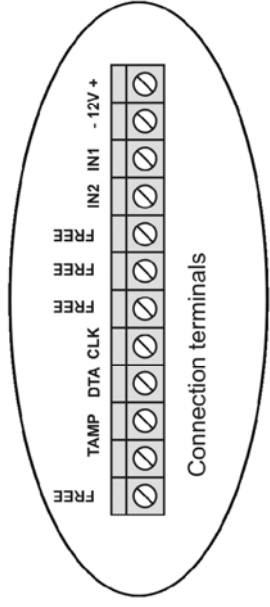
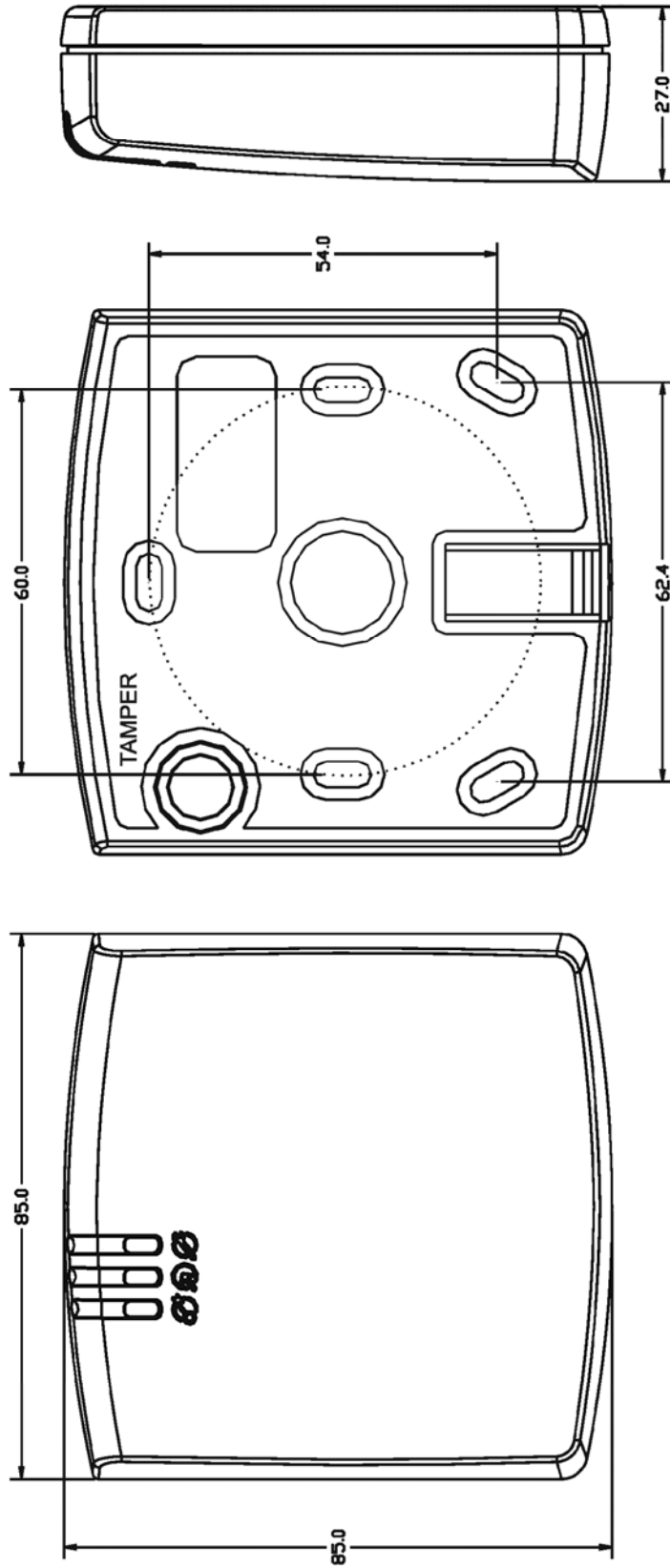
Views and installation diagram



-  LED STATUS (Armed/Disarmed)
-  LED OPEN
-  LED SYSTEM

rcdr054

Wiring PRT-LT reader with various controllers

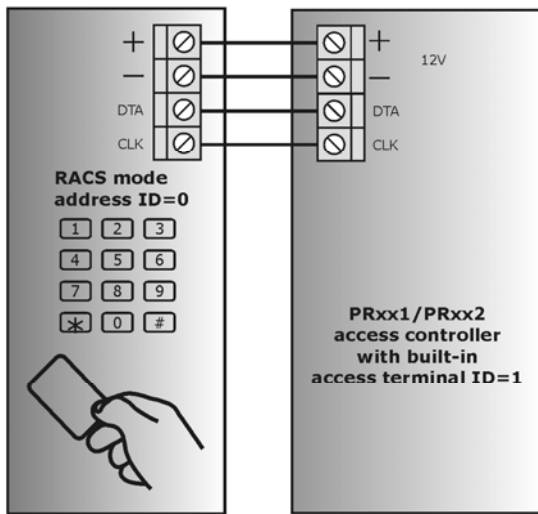

Connection to PRxx1/PRxx2 series access controller with built-in ID1 terminal

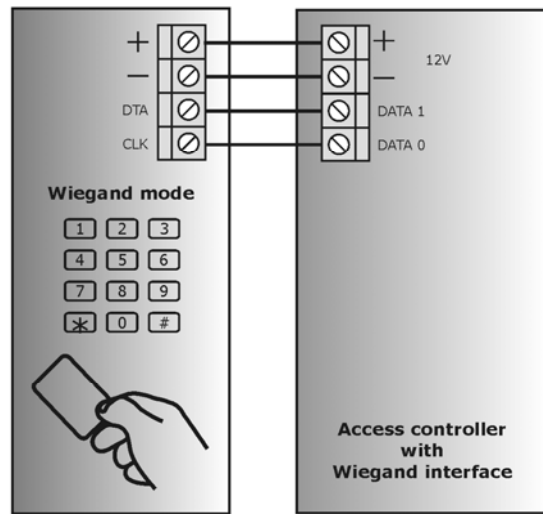

Connection to access control unit with Wiegand interface

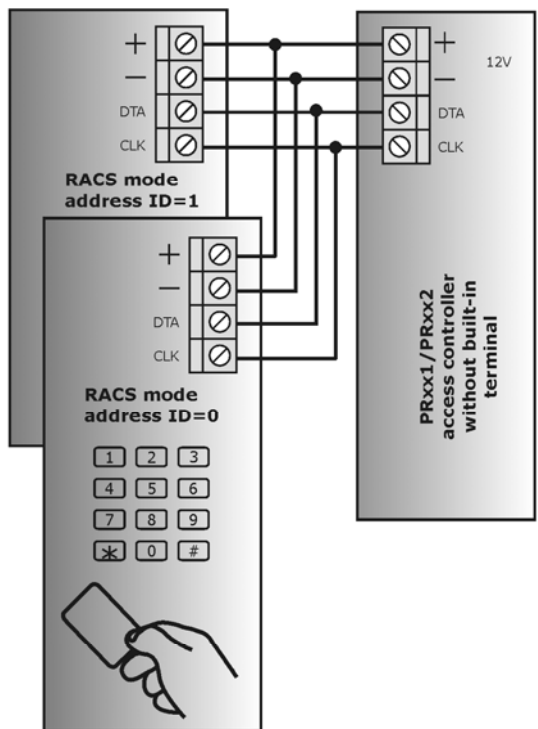

Connection to PRxx1/PRxx2 series access controllers (two-way door control)

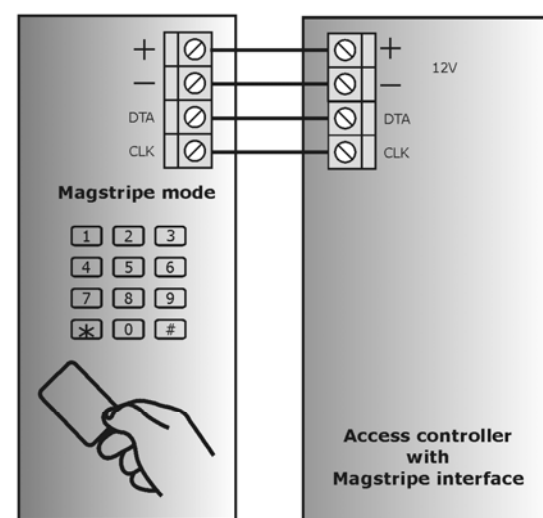

Connection to access control unit with Magstripe interface

rcdr060

Technical Specification	
Supply voltage	10-15 VDC
Current consumption (average)	PRT12LT: 65mA PRT12LT-BK: 45mA PRT32LT: 65 mA PRT42LT: 65 mA PRT42LT-BK: 45mA PRT62LT: 45mA PRT64LT: 65mA PRT66LT: 45 mA
Reading distance	PRT62LT: up to 12 cm, others: up to 15 cm Note: Reading distance is defined for good quality proximity cards placed in optimal position against the reader. For all PRT-LT readers optimal card position is in the front of the reader (card surface parallel to front of the reader)
Anti-sabotage protection (Tamper)	NC contact, 50mA/24V, IP67
Proximity cards	EM 125KHz (EM4100/4102 compatible)
Communication distance	Between ACU and PRT reader: max. 150 m Between main PRT reader and external PRT reader: max. 150 m
Environmental class (according to EN 50131-1)	Class IV, outdoor-general, temperature: -25°C- +60°C, relative humidity: 10 to 95% (non condensing) Class I, Indoor, temperature: +5°C- +40°C, relative humidity: 10 to 95% (non-condensing) PRT12LT/PRT12LT-BK: Class IV PRT32LT: Class I PRT42LT/PRT42LT-BK: Class I PRT62LT: Class IV PRT64LT: Class IV PRT66LT: Class IV
Dimensions H x W x D	PRT12LT/PRT12LT-BK: 150.5 X 46 X 23 mm PRT32LT: 105 X 105 X 31 PRT42LT/PRT42LT-BK: 151.5 X 45 X 20.5 mm PRT62LT: 100 X 45 X 25 mm PRT64LT: 115 X 80 X 35 mm PRT66LT: 85 X 85 X 27 mm
Weight	PRT12LT/PRT12LT-BK: 150g PRT32LT: 140g PRT42LT/PRT42LT-BK: 90g PRT62LT: 100g PRT64LT: 120g PRT66LT: 120g
Approvals	CE

Ordering Codes	
PRT12LT	Outdoor proximity reader with keypad, laser engraved long durability silicon rubber keypad, two function keys, dark grey ABS enclosure, pig-tail cable
PRT12LT-BK	The same as PRT12LT but without keypad
PRT32LT	Indoor proximity reader with keypad, light grey top/dark grey bottom, reader can be re-armed on the field to non-keypad version, ABS enclosure, screw terminals
PRT42LT	Indoor proximity reader with plastic keypad, one function key, dark grey ABS enclosure, screw terminals
PRT42LT-BK	The same as PRT42LT but without keypad, one function key
PRT62LT	Outdoor, miniature proximity reader without keypad, dark gray ABS enclosure, pig-tail cable
PRT64LT	Outdoor, proximity reader with keypad, dark gray ABS enclosure, screw terminals
PRT66LT	Outdoor, proximity reader without keypad, dark gray ABS enclosure, screw terminals

Product History			
Hardware	Firmware	Date	Description
V1.0	fv1.25	29/10/09	Initial product version



The symbol of a crossed-through waste bin on wheels means that the product must be disposed of at a separate collection point. This also applies to the product and all accessories marked with this symbol. Products labeled as such must not be disposed of with normal household waste, but should be taken to a collection point for recycling electrical and electronic equipment. Recycling helps to reduce the consumption of raw materials, thus protecting the environment.

Contact

Roger sp. j.

82-400 Sztum

Gosciszewo 59

Tel.: +48 55 272 01 32

Fax: +48 55 272 01 33

Technical support PSTN: +48 55 267 01 26

e-mail: suport@roger.pl