

Installation Guide
for
PR611 and PR621 v1.0
Access Controllers
Rev. B

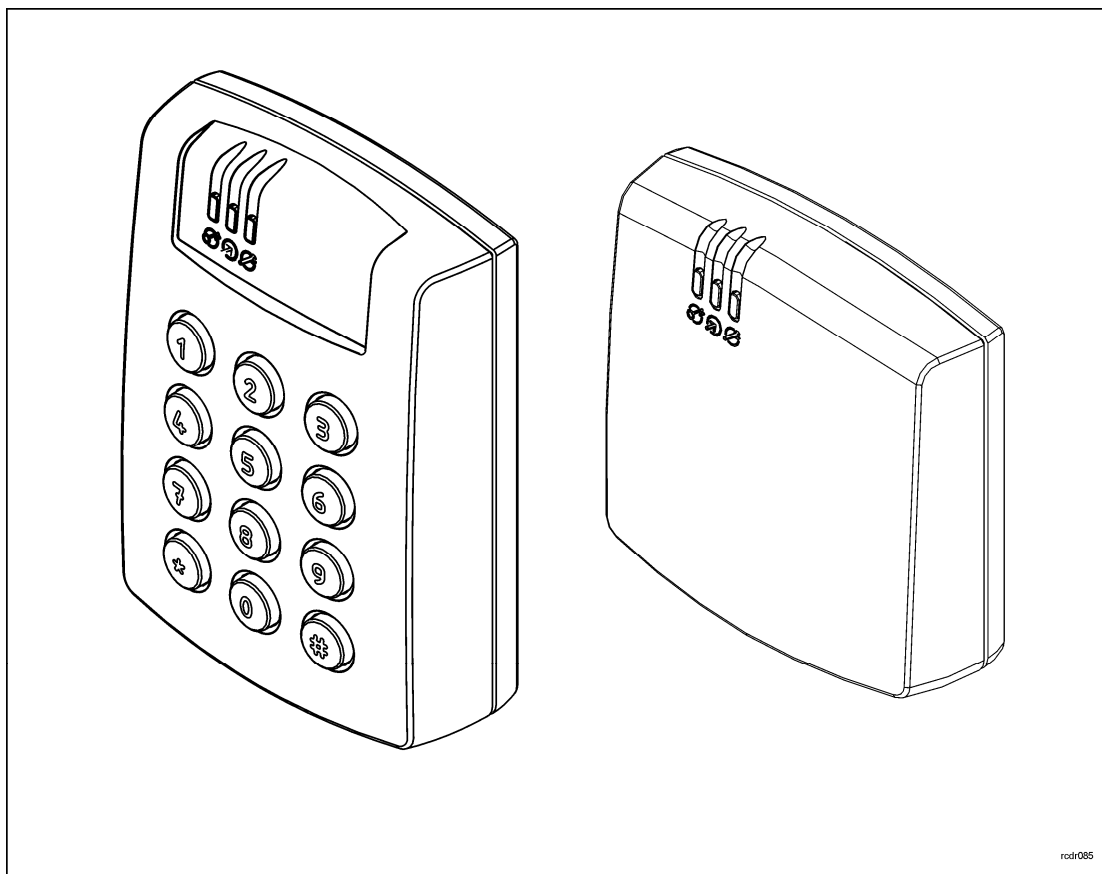

Introduction

This document contains minimum information that is necessary to properly install the device and to perform its initial testing. **Full description of the controller has been included in the general user guide for the PRx11 series controllers, which is available at www.roger.pl.**

The controller can be programmed manually or with a PC. Connecting the controller to the PC requires utilization of the relevant communication interface (UT-2, UT-2USB, UT-4 or RUD-1) however the RUD-1 is most suitable for this purpose because provides 12V DC output which can be used to supply programmed device. Manual programming can be performed locally using the device's keypad (PR611 only) or using an additional, PRT series reader connected to the main PR611/PR621 controller unit (the reader connected to programmed controller should be equipped with a keypad and configured to "RACS mode address ID0"). Later, for device's programming a so called **Programming Cards** can be used. Programming Cards are standard proximity cards which were assigned specific programming functions. Programming Cards can be defined during device's configuration process.

Note: The PR611/PR621 require the PR Master 4.3.1 or higher.

Controller Installation

The controller can be installed both inside and outside of buildings and does not require additional protections against rainfalls (snowfalls) as well as humidity. All the electrical connections can be done only when the power supply is disconnected. The new, factory-made controller, has the address ID=00 and is equipped with the programmed MASTER card delivered with a new device. The card can be used for the initial testing of the device after the installation.

All the devices connected to the AC system's RS 485 communication bus should have the common minus (GND). In order to ensure this, all the GND terminals of power supply units used in the system should be connected together with the separate wire. The other solution is to individually ground (connect to earth) each of GND terminals. However, the latter solution is not recommended, because when grounding potentials in different locations of installation are not the same, the equalizing current will flow through the system's power supply lines. That in turn, can cause disruption of system work or even its damage.

Readers can be installed on metal surfaces but in such cases the reading distance reduction should be expected. The reading distance reduction effect can be minimized by installing readers on the non-metal plate spacer. The thickness of such spacer should be at least 10 mm. The distance between two proximity readers should not be less than 0.5m. In case the two readers are mounted on opposite sides of the same wall it is recommended that they not create the same geometrical axis. If this is not possible, a metal plate beneath each of the readers should be installed. Additionally, between each reader and the plate the non metallic spacer of minimal 10 mm thickness should be put.

The controller is equipped with 6 installation holes in bottom of the enclosure. The distance between two of them placed horizontally is 60 mm, which make it possible to install the device in the standard flush-mounted gang box.

Note: Under no circumstances the positive terminals of the power supply units in the system would be connected together. The note applies also for the supply leads available in controllers with its own power supply (e.g. PR411, PR402).

Address Setting

Before the controller is connected to the communication bus of the RACS, the unique address (ID number) should be assigned to it. A new address setting can be performed during the **Memory Reset** procedure or from the PC with managing program. In order to change the address from the PC, the controller should be connected using the communication interface (UT-2, UT-2USB, UT-4 or RUD-1) however the most preferred is RUD-1 which provides 12V CD output to supply the programmed unit. Then the controller should be find using PR Master program, and finally its destination address should be assigned. The RACS 4 supports addresses from the 00-99 range.

Presence of two or more devices having the same address causes the communication bus conflict and makes a proper communication with the device impossible.

Note: A new controller can be connected to the existing system without the necessity to change its address, however only under condition that no controller existing in the system has the address identical to the address of the newly connected device (e.g. 00). After the controller is connected to the communication bus, it should be found in the management software and the destination address should be assigned to it.

Power Supply

The controller requires 12V DC nominal power supply. The power should be connected to the +12V line (positive terminal) and the GND (negative terminal). Apart from powering function, the GND terminal plays also the role as reference potential for the RS485 bus' communication lines, IN1-IN3 inputs and CLK/DTA interface lines.

Connecting Door Unlocking Device

In majority of cases, door unlocking devices have inductive characteristics. It means that turning off the current flowing through the device may cause the electrical overvoltage condition which can interfere with the controller operation. In extreme cases it may lead to the controller's hanging up. Moreover, the presence of overvoltages causes quicker attrition of the relay's contacts. In order to limit negative impact of overvoltages, it is necessary to utilize a semiconductor diode of general use e.g. 1N4007 (one piece of such diode is delivered with the controller). It should be connected as close as possible to the inductive element (electric strike or magnetic lock). The door lock device element can be supplied from the same power source as the controller but for such purpose the separate pair of wires should be used and connected directly to the power supply's terminals.

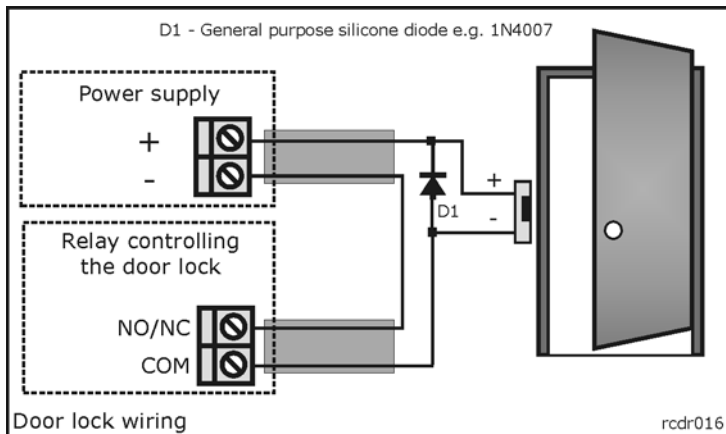

Output Lines

All the controller's inputs (IN1, IN2 i IN3) have identical electric structure and can be configured as lines of NO or NC type. The NO input is triggered by applying supply minus to it, the NC input must be normally shorted to the supply minus (GND) and is triggered by disconnecting it form the minus. Every input is internally connected (pulled up) to the power supply plus (+12V) through a 5.6kΩ resistor.

Relay Outputs

The relay output REL1 offers one switched contact rated 24V/1.5A. The relay's contacts are internally protected against overvoltages by semiconductor elements. However this does not take the responsibility out of the installer to eliminate interferences from inductive elements by an additional diode. It is forbidden to use relay output to switch voltages above 30V because this for sure will cause damage to the semiconductor elements protecting the relay's contacts. In the normal state (the relay is off) the NC-COM contacts are shorted. In the triggering state (the relay is on) the NO-COM contacts are shorted. In case of lack of the power, the REL1 output is in the off state.

Transistor Outputs

There are two transistor outputs (IO1 and IO2) available in the controller. The lines are of the open collector type, i.e. in the normal (off) state represent high impedance and in the triggering state (the output is on) they short to supply minus. The IO1/IO2 lines can switch current up to max 1A DC while voltage connected to the output must not exceed 15V DC. In case of over-current state, the IO1/IO2 lines are automatically switched off and the controller automatically restarts.

Note: If you observe that triggering IO1/IO2 output makes device to restart it might suggest that current switched by the output exceeds its maximum allowed level.

RS485 Communication Bus

The RS485 bus consists of two signal lines A and B. In the RACS 4 any communication bus topology can be used (star, tree or any combination of the two), in other words RACS 4 accepts free bus topology. The matching resistors (terminators) connected at the ends of transmitting lines are also not required. In majority of cases communication works without any problems using any cable type (ordinary telephone cable, shielded or unshielded twisted pair etc. e) but the recommended one is an unshielded computer twisted pair one. Using shielded cables should be limited to installations liable to strong electromagnetic interferences. RS485 communication standard used in the RACS 4 guarantees a proper communication in a distance up to 1200 meters and features a high resistance to interferences. For communication on longer distances, the UT-3 or UT-4 interface should be used. A pair of UT-3 interfaces increases communication distance by additional 1200 m, and using an UT-4 interface makes possible to utilize communication through a computer network (LAN or WAN).

Connecting Readers and Extension Modules

The controller can cooperate with one additional reader of PRT series configured to RACS mode with ID0 address. It can also cooperate with XM-2 I/O extension module. Both an additional reader and an extension module can be connected to the controller using the same CLK and DTA lines. For CLK and DTA lines any type of cables can be used as well. The guaranteed communication distance is 150 meters. Each device connected to CLK/DTA lines must have its individual address from 0–15 range. This address should be set up before particular device is connected to the controller.



Note: Devices communicating using the RACS Clock & Data standard (e.g. PRT readers) can be connected to the controller with cables significantly longer than 150m (even up to 500m), but the communication in such conditions is not guaranteed by the vendor.

Memory Reset

The **Memory Reset** procedure clears all existing controller settings, restores factory ones, and enables for enrolment of the new MASTER card/PIN and new ID number (address) of the controller. After **Memory Reset**, the controller automatically switches to normal working mode.



Simplified Memory Reset Procedure (version 1)

This method clears entire memory and allows for programming of a MASTER card however doesn't allow for programming of the controller's address (address is set to ID=00). This procedure doesn't require use of a keypad.

- Remove all connections from CLK and DTA lines
- Short CLK and DTA lines
- Restart device (switch power supply off and then on or short RST contacts for a while) – all the LED indicators on the reader will be lit
- Remove the bridge between CLK and DTA lines – the LEDs on the reader will be off, and the LED OPEN  (green) will start flashing
- While the LED OPEN  is flashing, read any card – this will be the new MASTER card
- The reader will restart automatically and return to normal mode of operation

Simplified Memory Reset Procedure (version 2)



This method clears entire memory and allows for programming a MASTER card and allows to set ID address. This procedure doesn't require use of a keypad.

- Remove all connections from CLK and IN3 lines
- Short CLK and IN3 lines
- Restart device (switch power supply off and then on or short RST contacts for a while) – all the LED indicators on the reader will be lit
- Remove the bridge between CLK and IN3 lines – the LEDs on the reader will be off, and then the LED STATUS  and LED OPEN  (green) will start flashing
- While the LED OPEN  is flashing, read any card – this will be the new MASTER card then move to the next step where you will program controller's ID number (address)
- Read MASTER card X times where X must be equal to the first digit of the required address then wait for two short beeps
- Read MASTER card Y times where Y must be equal to the second digit of the required address
- The reader will restart automatically and return to normal mode of operation

Full Memory Reset Procedure

This procedure can be performed directly from the controller's keypad (if the controller has it) or from an additional PRT series reader connected to the controller through CLK and DTA lines. The reader used for this should be configured to the **RACS mode address ID0** and be equipped with a keypad. Full Memory Reset procedure clears entire memory and allows for programming a MASTER card and PIN as well as setting up a new address (ID number).

- Remove all connections from CLK and DTA lines.
- Short CLK and DTA lines.
- Restart device (switch power supply off and then on or short RST contacts for a while) – all the LED indicators on the reader will be lit.
- Remove the bridge between CLK and DTA lines – the LEDs on the reader will be off, and the LED OPEN  (green) will start flashing.
- If the controller is equipped with keypad go to the next step if not then without switching the power off connect an external PRT series reader to it. It should be configured to the RACS mode address=ID0. The rest of the steps should be performed using this additional reader.
- Enter a new MASTER PIN code (3-6 digits) followed with the [#] key or skip this step pressing the [#] key alone.
- Read any card – it will be a new MASTER card – or skip this step by pressing the [#] key.
- Enter two digits (from 00 to 99 range). These digits program a new ID address of the controller. Eventually, instead of programming controller's address can press the [#] key alone. In the latter case, the controller will automatically assume address ID=00.
- After this action, the reader will restart automatically and return to normal working mode (enters Armed mode).

After **Memory Reset** procedure, controller resumes its work with default configuration settings. You can then initially test its operation using a MASTER ID card or PIN (if they were programmed). Using the MASTER card or PIN once, activates a relay output REL1 for 4 seconds and LED OPEN  in on along with REL1. Using it twice switches the IO1 output to the opposite state, and changes a current controller's armed mode (LED STATUS  changes its color).

Firmware Upgrade

During manufacturing process controller is programmed with a latest available version of firmware. The firmware can be later upgraded to newer versions. Detailed description of the firmware upgrade procedure can be found in the *Firmware upgrade.pdf* manual available at www.roger.pl. Loading an upgraded firmware to the controller is done using RS485 communication bus and does not require dismounting the device from the place of installation. RogerISP is the software used for upgrading firmware (it can be downloaded at www.roger.pl). After the firmware is upgraded, always perform the **Memory Reset** procedure and assign a proper ID address to the controller. If the controller being upgraded worked in the RACS system before, you need to assign to it appropriate ID address after the upgrade (the same which it was assigned before the upgrade). Then, you need to go to the PR Master managing software, and run the command:

/Subsystems/Controllers/Commands/Restart, verify type and version – the operation will update data related to the controller’s firmware version in the RACS system database.

Note: Together with the controller’s firmware upgrade, you need also to update the managing PR Master software.

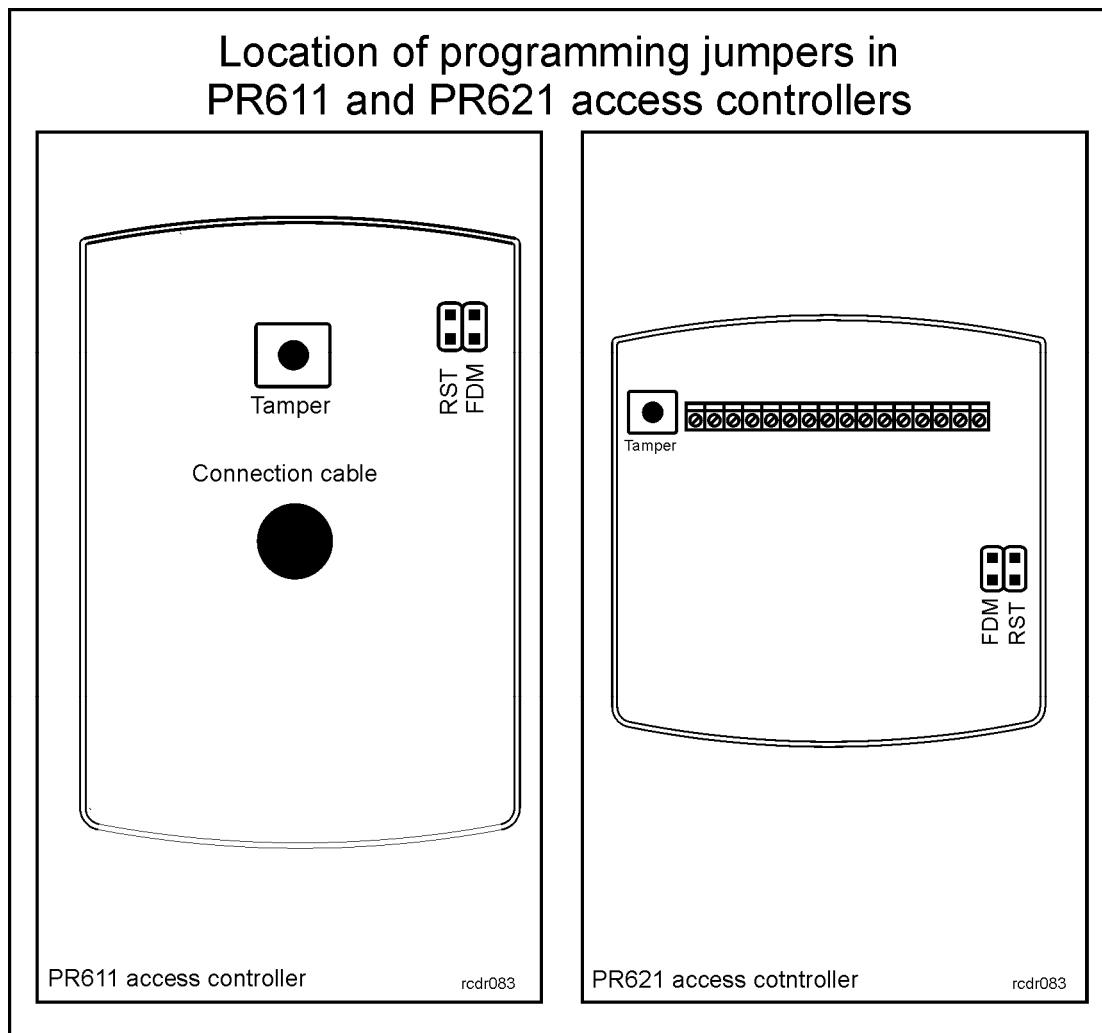

Installation Notes

- Installer should install the device in such a way that, when needed, he has access to a connecting cable (contacts) as well as to the reader programming contacts (pins RST and FDM).
- Before the controller is installed, it is recommended to assign the destination address (ID number) to it.
- Together with the controller a proximity MASTER card is delivered. Nevertheless, for the MASTER card function any proximity card of the EM 125 KHz standard can be programmed later.
- When the MASTER card or PIN is lost or stolen, it can be programmed from scratch.
- The reader should be mounted on the vertical piece of the wall, close to a door being controlled.
- All the electrical connections should be done only when the power supply is disconnected.
- In case of installation on metal surfaces, it is recommended to put a non-metallic spacer under the reader, which should be at least 10 millimeters thick.
- When it is necessary to install readers on opposite sides of the same wall and in the same geometrical axis, a metal plate should be put between the readers, and the readers should be installed on a non-metallic spacer 10 mm thick at a minimum.
- It is recommended that the reader be installed at a distance not lower than 0.5 m from the other reader.
- All the devices communicating between themselves (readers, extension modules, controllers) should have be connected to the same, common minus potential.
- Optionally, system supply minus can be earthed in one arbitrary selected location. Do not connect system supply minus to the earth in more than one place.
- Because of relatively low magnetic field, the reader should not interfere with other devices' operation, however its operation can be disrupted by devices generating a strong electromagnetic field.
- In case when the range of card reading is significantly lower than specified in the technical documentation, changing reader's installation location should be considered.
- A silicone diode of general use e.g. 1N4007 should be always connected in parallel the door locking device (magnetic lock, electric strike, relay, contactor) — one piece of such diode is delivered with the controller. It should be connected as close as possible to the inductive element.
- Door locking equipment should be powered using a separate pair of wire connected directly to power supply output terminals.
- Powering door lock directly from reader's supply contacts can cause pervading interference to an electronic module and disrupt the device's operation.

Connections			
Name	Terminal number (for products equipped with screw terminals)	Wire Color (for versions equipped with pig tail cable)	Purpose
+12V	1	Red	Positive power supply contact, 10–15V DC
GND	2	Black	Negative power supply contact and reference potential for RS485 communication bus, inputs and CLK/DTA interface
IN1	3	Pink	IN1 input line, internally connected to the power supply plus (+12V) through a 5.6kΩ resistor
IN2	4	Blue	IN2 input line, internally connected to the power supply plus through a 5.6kΩ resistor
IN3	5	White-yellow	IN3 input line, internally connected to the power supply plus through a 5.6kΩ resistor
RS485-B	6	Green-white	RS485 communication bus, B line
RS485-A	7	Brown	RS485 communication bus, A line
CLK	8	White	RACS Clock & Data communication interface, CLOCK line
DTA	9	Green	RACS Clock & Data communication interface, DATA line
TMP-A	10	Yellow	Anti-sabotage contact, line A, rated 24V/50mA
TMP-B	11	Grey	Anti-sabotage contact, line B, rated 24V/50mA
IO2	12	Green-brown	IO2 transistor output of open collector type, rated 15V DC/1.0A
IO1	13	Yellow-brown	IO1 transistor output of open collector type, rated 15V DC/1.0A
REL1-NC	14	Grey-pink	REL1 relay output, contact normally closed rated 24V/1.5A
REL1-COM	15	Red-blue	REL1 relay output, common contact, rated 24V/1.5A
REL1-NO	16	Violet	REL1 relay output, contact normally open rated 24V/1.5A

Technical Data	
Supply voltage	10-15 VDC
Current consumption	PR611: average 70 mA PR621: average 50 mA
Tamper	Isolated contact, NC type, 50 mA/24V rated
Reading distance	Up to 15 cm for ISO cards (depends on card type and quality)
Proximity cards	EM 125 KHz (EM4100/4102 compatible)
Distances	RS485 comm. bus: up to 1200m Between an additional reader and the controller: max 150 m Between a reader and XM-2/XM-8 expansion modules: max 150 m
Environmental class (according to EN 50131-1)	Class IV, outdoor general conditions, temperature: -25°C- +60°C, relative humidity: 10 to 95%
Dimensions	PR611: 115 X 80 X 35 mm PR621: 85 X 85 X 27 mm
Weight	~ 120g
Certificates	CE

Ordering Information	
PR611	PR611 controller, standard version, connection via pig tail cable
PR621	PR621 controller, standard version, connection via screw terminals
RM-2	Module consisting of two relay outputs rated 1.5A/24V each with one switched contact NO/NC. Relay contacts are protected against overvoltages using metal-oxide varistors (MOVs). Relays can be triggered by applying low as well as high triggering signal. Triggering of relay is indicated by LED on the module's board.
RM-2 PCB	RM-2 PCB module without enclosure
XM-2	Input/output addressable extension module provides two input lines NO/NC and two relay outputs with one switched contact NO/NC rated 1.5A/24V. Relay contacts are protected against overvoltages using metal-oxide varistors (MOVs). Triggering of each relay is indicated by a LED installed on the module's board. Communication with parent device can be performed using CLK/DTA lines. The module can be located in a distance of 150 m from the host device (controller).
XM-2 PCB	XM-2 PCB module without enclosure
UT-2	RS232-RS485 communication interface
UT-2USB	USB-RS485 communication interface
RUD-1	USB-RS485 communication interface with 12V DC/150mA supply output
UT-4	Ethernet-RS485/RS232 communication interface

Contact

Roger sp. j.

82-416 Gościszewo

Gościszewo 59

Tel.: +48 55 272 01 32

Fax: +48 55 272 01 33

Technical support PSTN: +48 55 267 01 26

Technical support GSM +48 664 294 087

e-mail: biuro@roger.pl

	<p>Such symbol on the product or its package means that the product should not be disposed together with other wastes, because it may cause negative effects to environment and humans health. User is responsible for delivering used equipment to the allotted locations for gathering used electrical and electronic devices. Detailed information on recycling can be found at relevant local authorities, in a disposing company or in a place, where the product was bought. Separate gathering and recycling of such wastes contributes to natural resources protection and is safe for humans health and for natural environment. The equipment's weight is shown in the guide.</p>
---	---

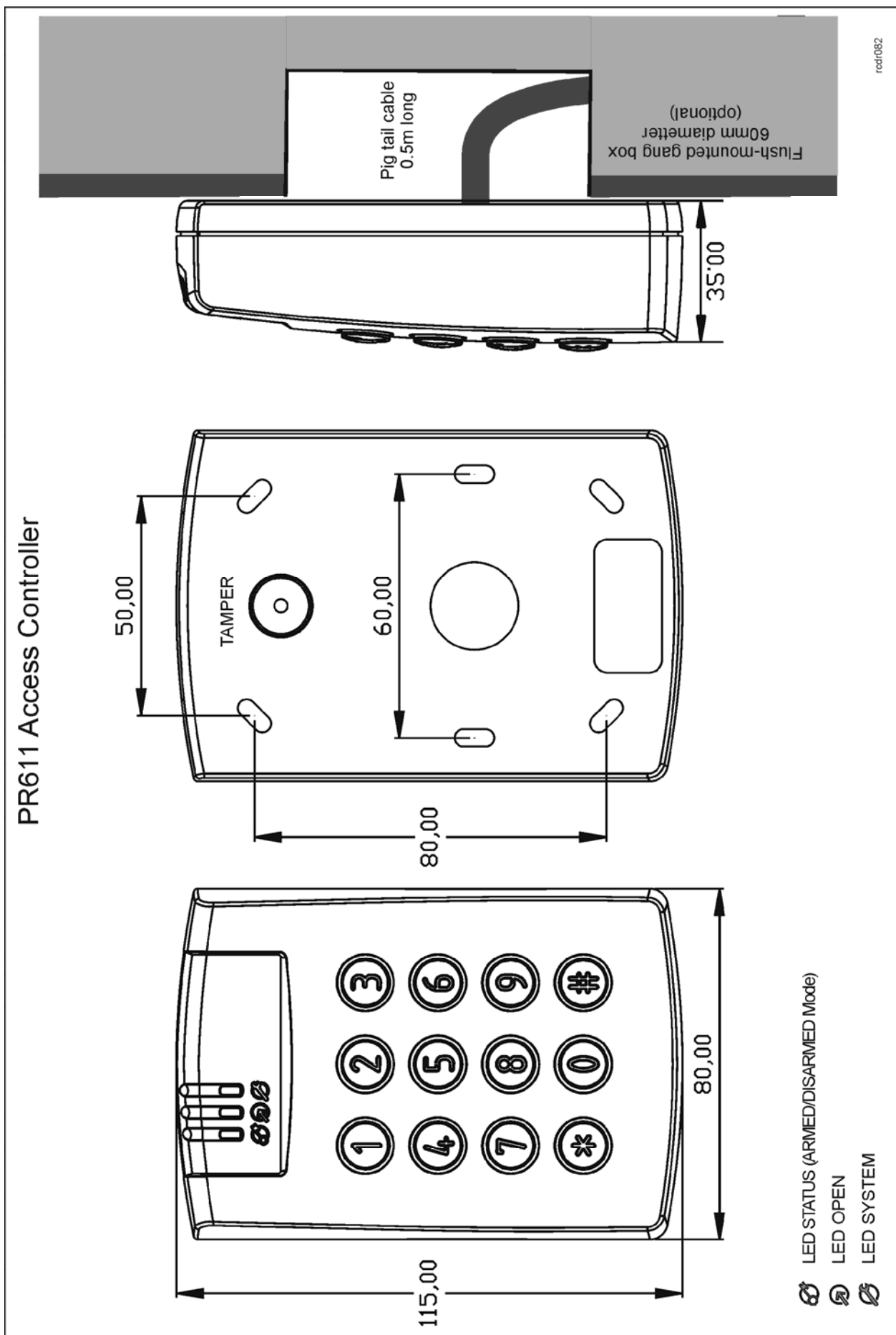

- LED STATUS (ARMED/DISARMED Mode)
- LED OPEN
- LED SYSTEM

PR621 Access Controller

