

*Roger Access Control System*

## Installation guide for HRT82TS temperature sensor module

*Firmware version: 1.0.8.23 or newer*

*Hardware version: 1.0*

*Document version: Rev. C*

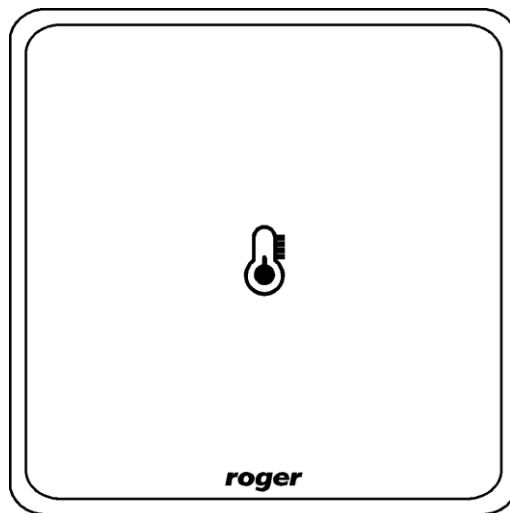

rcdr198

# 1. INTRODUCTION

This manual contains minimum information that is necessary to properly install device. Following documents supplement this manual:

- Functional description of HRC series controllers
- Installation guide for HRC series controllers

In order to acquire the first one it is necessary to obtain Roger consent and sign non-disclosure agreement (NDA). The second one is available at [www.roger.pl](http://www.roger.pl).

# 2. DESCRIPTION AND SPECIFICATION

HRT82TS temperature sensor module is peripheral device used in a hotel system based on HRC series controllers. The module communicates with controller using RACS CLK/DTA bus and enables room temperature readout allowing the controller to control air conditioning and/or heating systems. Interchangeably, room temperature can also be read by means of such devices with built-in temperature sensors as HRT82AC air conditioning control panel and HRT82MF-CH card holder.

| Table 1. Specification                   |  |
|--|--|
| Supply voltage                           | Nominal 12VDC, min./max. range 10-15VDC  |
| Average current consumption              | 25mA   |
| Tamper resistance                        | Isolated contact, NC type (normally closed when enclosure is assembled and attached), 24V/50mA                 |
| Distance                                 | Between controller and HRT device (RACS CLK/DTA): max. 150m  |
| Environmental class (acc. to EN 50131-1) | Class II, indoor general conditions, temperature: -10°C- +50°C, relative humidity: 10 to 95% (no condensation) |
| IP code                                  | IP41   |
| Dimensions HxWxD                         | 85 x 85 x 22 mm  |
| Weight                                   | ~ 100g   |
| Certificates                             | CE   |

# 3. INSTALLATION

## 3.1 Terminals and connection diagram

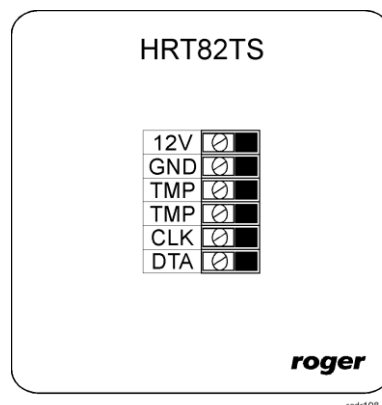

Fig. 1 HRT82TS temperature sensor

| <b>Table 2. HRT82TS terminals</b> |                    |       |                  |
|-----------------------------------|--------------------|-------|------------------|
| Term.                             | Description        | Term. | Description      |
| 12V                               | 12VDC power supply | TMP   | Tamper           |
| GND                               | Ground             | CLK   | RACS CLK/DTA bus |
| TMP                               | Tamper             | DTA   | RACS CLK/DTA bus |

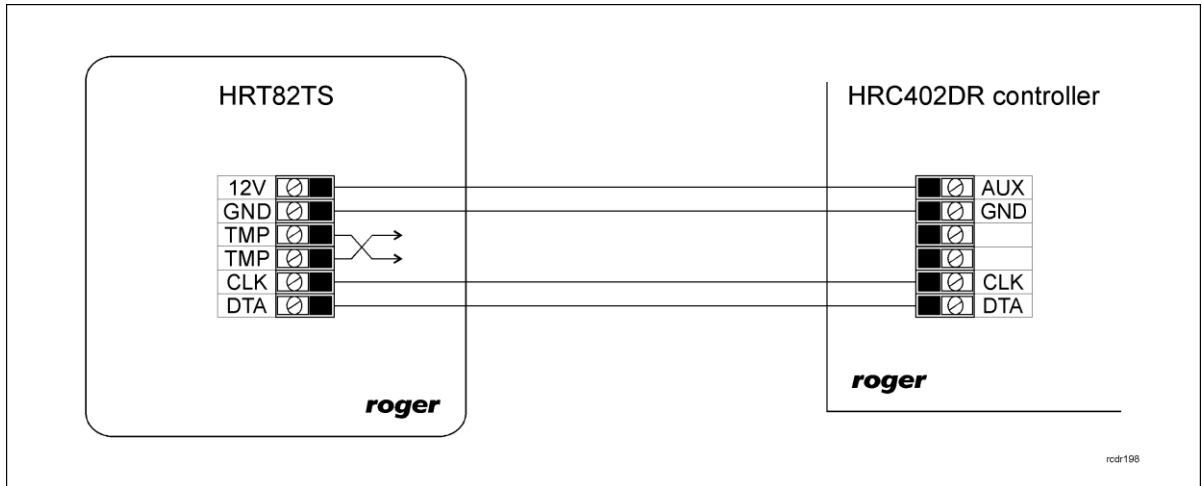

Fig. 2 Connection to controller with 12VDC power supply output

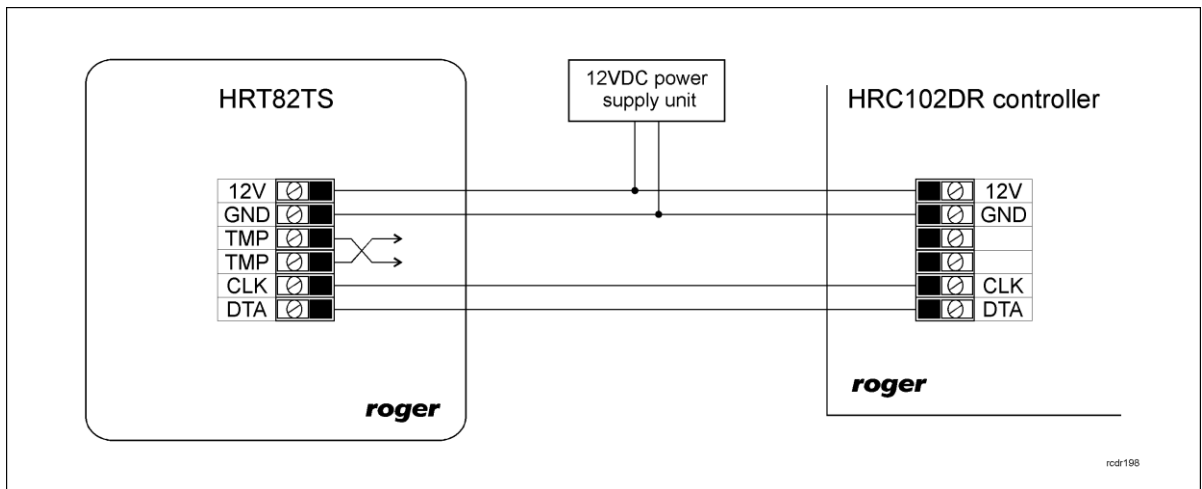

Fig. 3 Connection to controller without 12VDC power supply output

### 3.2 Power supply

HRT82TS requires 12VDC nominal power supply. The power must be connected to 12V and GND terminals. Additionally, the GND terminal is used as reference potential for the RACS CLK/DTA bus. HRT82TS power supply can be provided by connection to buffer power supply unit (e.g. PS-15DR, PS20) or connection to AUX output of HRC402DR controller (see fig. 2). Backup battery connected to power supply unit or directly to HRC402DR controller can be used in order to ensure operation in case of 230VAC power failure.

---

Note: All devices connected to the same RACS CLK/DTA bus must be connected to common reference potential (GND).

---

### 3.3 RACS CLK/DTA communication bus

RACS CLK/DTA is the addressable bidirectional communication standard developed and applied in Roger controllers in order to enable their communication with peripheral devices. Addresses of all devices connected to CLK and DTA lines must be properly configured in range of 00..15. Standard unshielded signal cables (e.g. U/UTP cat. 5) with maximal length of 150m can be used for RACS CLK/DTA communication.

### 3.4 Front panel

HRT82TS is equipped with front icon backlight which is used for signalling proper operation (steady light) or communication problems (blinking).

### 3.5 Wall mounting and installation guidelines

HRT82TS consists of front panel and base which are factory assembled and require manual disassembly prior to installation according to fig. 4.

#### Installation guidelines

- Install device on wall far from sources of heat and moisture
- It is recommended to install device on Ø60mm flush mounting box
- Front panel and base must be properly oriented in order to ensure functioning of tamper resistance.
- All electric connections must be made with power supply switched off
- Run connection wires through hole in device base and then connect wires to screw terminals
- If device and controller are supplied from different power supply units then it is necessary connect GND terminals of both devices
- Front panel can be regularly cleaned with wet cloth and mild detergent. Do not clean by means of abrasive materials and strong cleaners like alcohols, solvents, etc.
- Damages resulting from improper maintenance or use are not covered by warranty

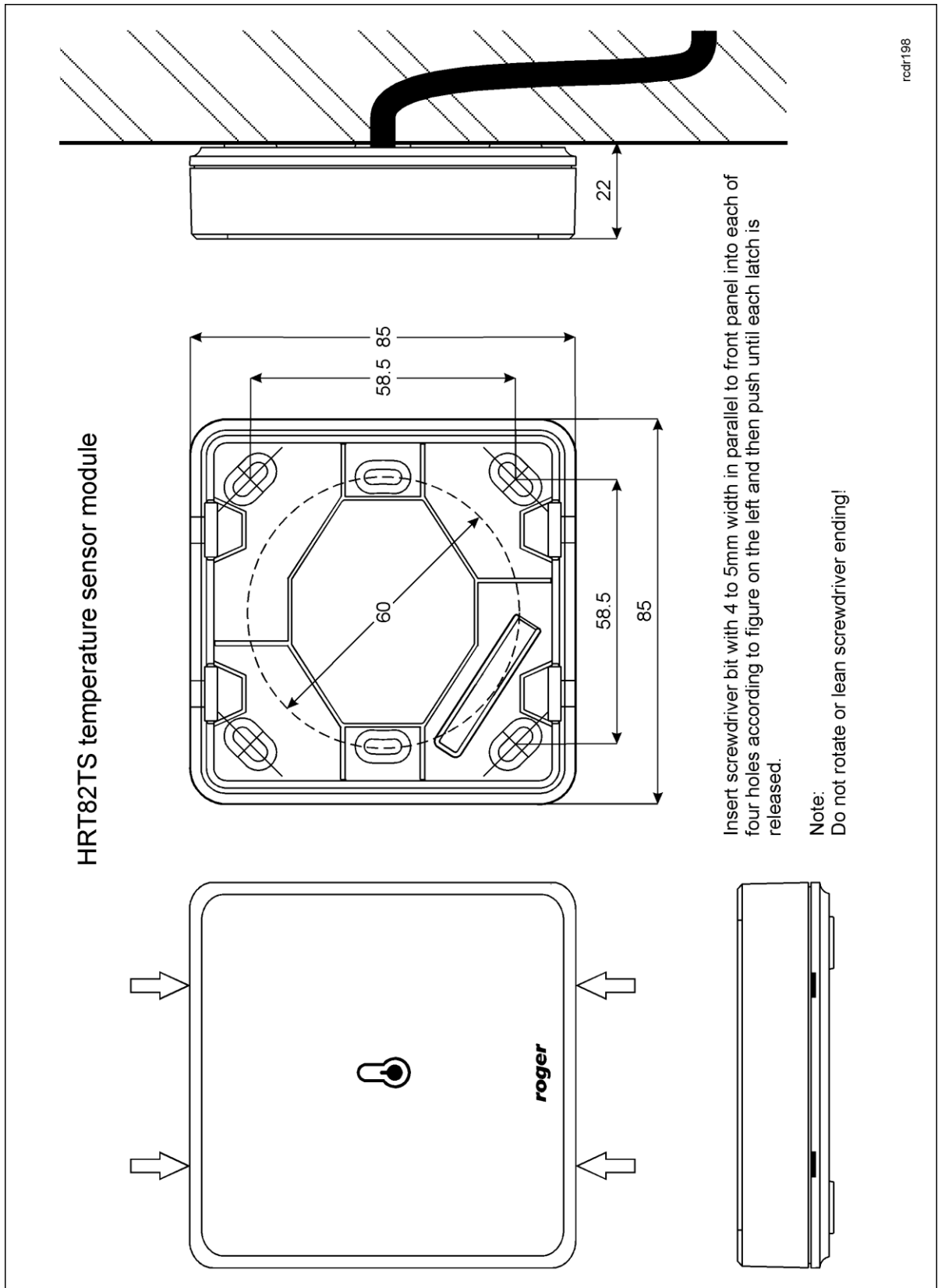

Fig.4 HRT82TS latches and wall mounting

## 4. CONFIGURATION

### 4.1 Device programming

The address of factory new HRT82TS is ID=7 and such device is ready to communicate with HRC series controller requiring no additional configuration. The same address is used by HRT82AC air conditioning control panel. Therefore particular controller can operate with only one of mentioned devices at the same time.

If necessary, HRT82TS settings can be modified with RogerVDM software (available at [www.roger.pl](http://www.roger.pl)) after connection to RUD-1 communication interface.

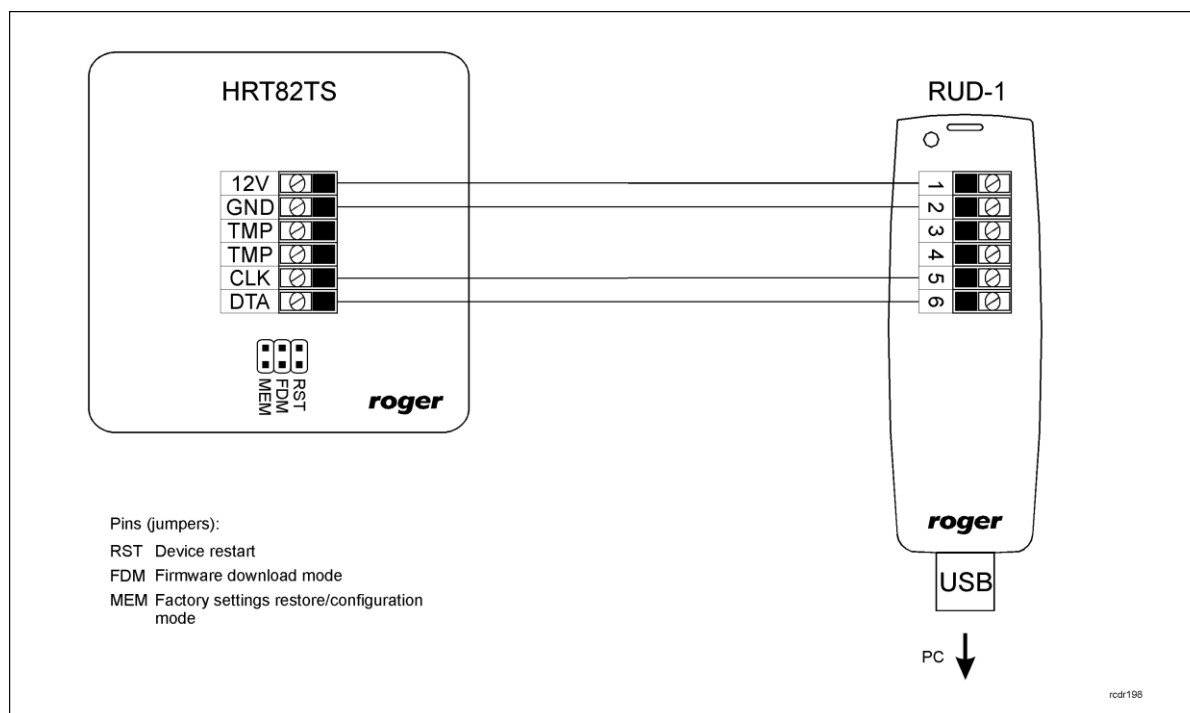

Fig. 5 HRT82TS and RUD-1 connection

#### Connection and configuration procedure

1. Connect device to RUD-1 communication interface according to fig. 5
2. Place jumper on MEM pins
3. Restart the device (place and remove jumper on RST pins or switch power supply off and on)
4. Install and start RogerVDM software
5. In the opened window select device, firmware version, communication channel and serial port with connected RUD-1 – see fig. 6
6. Select *Connect* button, the software shall establish connection with the device and automatically switch to configuration window
7. Enter required settings (configuration window is shown in fig. 7, while options are described in table 3)
8. Select *Send to Device* button – the software shall upload new settings
9. Remove jumper from MEM pins
10. Restart the device (place and remove jumper on RST pins or switch power supply off and on)

#### Note:

During connection procedure placing jumper on MEM pins and restarting the device restores its factory default settings.

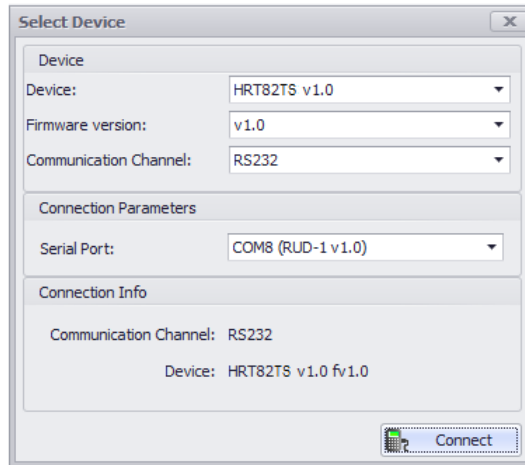

Fig. 6 Device select window in RogerVDM software

|                     |                       |      |
|---------------------|-----------------------|------|
| General             | Device Name           | none |
| Transmission Format | RACS CLK/DTA Address  | 1    |
|                     | Communication Timeout | 20.0 |

Fig. 7 Configuration window in RogerVDM software

| Table 3. Configuration parameters |                     |   |
|-----------------------------------|---------------------|---|
| Parameter                         | Values              | Description   |
| General                           |                     |   |
| Device Name                       | 16 ASCII characters | Device description which can be filled with any comment by installer.   |
| Transmission Format               |                     |   |
| RACS CLK/DTA Reader Address       | 0..15               | Device address on RACS CLK/DTA bus. Default address ID=7 is required for communication with HRC controller.                             |
| Communication timeout             | 0..255              | The device signals communication failure when selected timeout [0.5s] elapses. When 0 is selected then failure is not signalled at all. |

## 4.2 Firmware update

HRT82TS firmware can be updated with RogerVDM (available at [www.roger.pl](http://www.roger.pl)) after connection to RUD-1 communication interface.

### Firmware update procedure

1. Connect device to RUD-1 communication interface according to fig. 5
2. Install and start RogerVDM software
3. Close *Select Device* window
4. In top menu select *Tools->Update firmware*
5. In the opened window select device, port with connected RUD-1 and specify path to firmware file (\*.hex) – see fig. 8
6. According to displayed message place jumper on FDM pins and restart the device (place and remove jumper on RST pins or switch power supply off and on)
7. Select *Update* button
8. After firmware upload remove jumper from FDM pins and reset device (place and remove jumper on RST pins or switch power supply off and on)

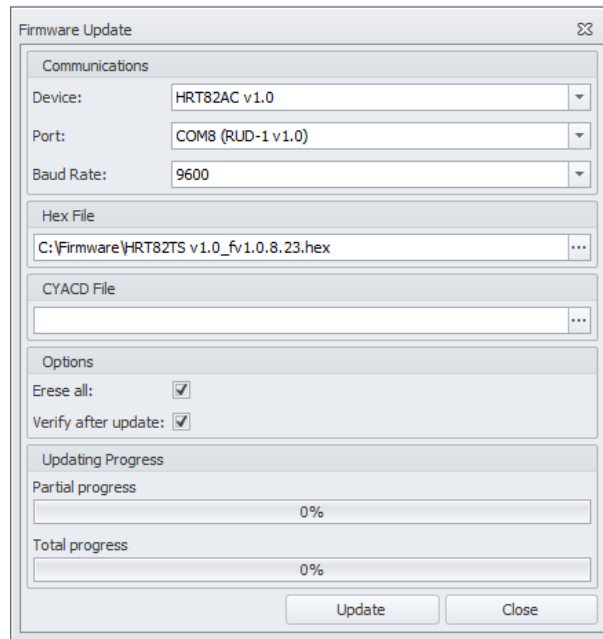

Fig. 8 Firmware update window in RogerVDM software

### 4.3 Memory reset

In order to restore HRT82TS factory default settings place jumper on MEM pins and then restart the device either by placing and removing jumper on RST pins or by switching power supply off and on. Moreover, memory reset is also part of connection and configuration procedure (see 4.1).

## 5. TROUBLESHOOTING

| Table 4. Troubleshooting         |                                      |                     |  |
|----------------------------------|--------------------------------------|---------------------|--|
| Issue                            | Visual indication                    | Acoustic indication | Solution   |
| No communication with controller | Front panel icon backlight blinking. | -                   | 1. Check if RACS CLK/DTA bus is properly connected, wires are undamaged and the bus does not exceed 150 m. All devices connected to particular RACS CLK/DTA bus should have common supply minus (GND).<br>2. Check if the controller is properly configured for communication with the device. |

## 6. ORDERING INFORMATION

| Table 5. Ordering information |  |
|-------------------------------|--|
| HRT82TS                       | Temperature sensor module                              |
| RUD-1                         | Communication interface with 12VDC power supply output |



## 7. PRODUCT HISTORY

| <b>Table 6. Product history</b> |          |   |
|---------------------------------|----------|---|
| Version                         | Released | Description                                 |
| HRT82TS v.1.0                   | 07/2015  | The first commercial version of the product |

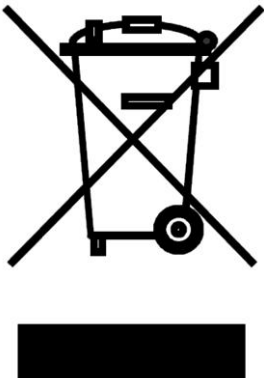
|  |   |
|--|---|
|  | <p>This symbol placed on a product or packaging indicates that the product should not be disposed of with other wastes as this may have a negative impact on the environment and health. The user is obliged to deliver equipment to the designated collection points of electric and electronic waste. For detailed information on recycling, contact your local authorities, waste disposal company or point of purchase. Separate collection and recycling of this type of waste contributes to the protection of the natural resources and is safe to health and the environment. Weight of the equipment is specified in the document.</p> |
|--|---|

**Contact:**  
**Roger sp. z o.o. sp.k.**  
**82-400 Sztum**  
**Gościszewo 59**  
**Tel.: +48 55 272 0132**  
**Fax: +48 55 272 0133**  
**Tech. support: +48 55 267 0126**  
**E-mail: [support@roger.pl](mailto:support@roger.pl)**  
**Web: [www.roger.pl](http://www.roger.pl)**