

PR602LCD v1.0  
Installer Manual  
Rev. A

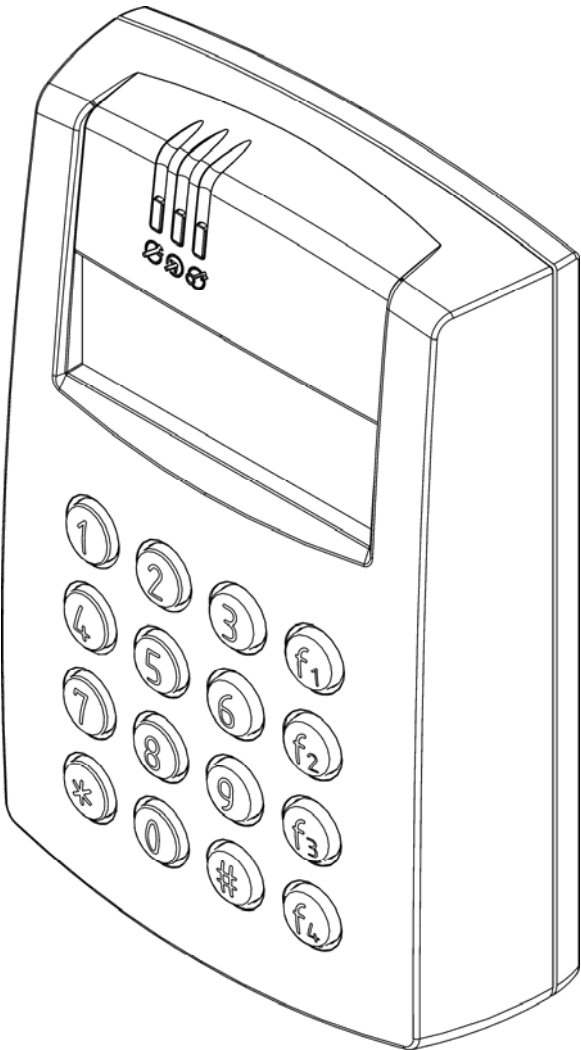

## Introduction

This document contains minimum information required for electrical connections and installation of the PR602LCD access controller in Roger Access Control System.

The full functional description of this product can be found in General Manual for PRxx2 Access Controllers available on [www.roger.pl](http://www.roger.pl)

---

**Note: The PR602LCD requires PR Master v4.2.6.8 or higher.**

---

## Installation

The PR602LCD can be installed either in internal or external locations and doesn't require any additional protection measures.

All electrical connections should be worked out before power supply will be applied. Factory new unit has ID number set to 00 and has pre-programmed MASTER PIN=1234 and MASTER card delivered with the device. The MASTER card/PIN can be used for initial testing of the controller's installation. If the unit has factory setting the single use of card/PIN MASTER will activate REL1 output for approximately 4 seconds while double use of card/PIN MASTER will change current arming mode of controller and will switch IO1 output to reverse state.

All devices connected to RACS communication bus should have common supply minus (common GND). This can be achieved by connecting all supply minuses with separate wire or connecting every supply minus with earth however this solution might create problems when electrical potentials of the earth are not the same in different parts of electrical installation.

---

**Note:** It is forbidden to short positive (+) outputs from different power supply sources used in the access system.

---

## Setting address

Before controller will be connected to communications bus it should have individual address (ID number=00..99). The controller's address can be set manually during Memory Reset procedure or connecting controller separately (without other controllers) to PC and then changing its address from PR Master program.

---

**Note:** Connecting two controllers with the same address will cause communications conflict which will corrupt system's behaviour.

---

## Power supply

Controller requires 10-15V DC power supply which should be connected to +12V (positive) and GND (negative) wires. Also, the GND line operates as reference potential for: inputs, RS485 and Clock/Data interface.

## Door Lock

In most cases the door locks are some kind of solenoid thus they represent inductive impedance. Such type of loads will create strong voltage pulse when current flows through this element is discontinued. This phenomenon may hang up electronic circuit or change its behavior. In order to protect system from these effects every inductive load should be protected with silicon diode (e.g. 1N4007) connected in parallel to inductive load and very close to it.

The door lock can be supplied from the same power source as electronic modules however it should be wired using separate pair of wires connected directly to power source but not to other electronic equipment connected to it.

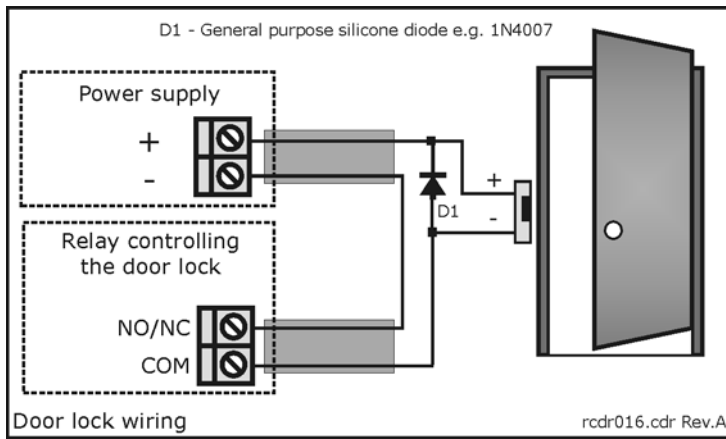

**Inputs**

Controller offers three inputs (IN1, IN2 and IN3), all of them have the same electric structure and might be configured as NO or NC. Normally, each input is internally biased to supply plus (+12V) through 5.6kΩ resistor.

The NO type input can be triggered by shorting it with supply minus (GND). The NC line should be normally tied to GND and will be triggered when connection with GND will be discontinued.

**Relay output**

Controller has one relay type output (REL1) which offers one NO/NC/COM contact 24V/1.5A rated. The relay’s contact are internally protected with semiconductor components which are dedicated to protect relay’s contact from sparks when switch high current. Those components will be damaged when voltage over 30V will be applied to relay’s contacts therefore the 24V AC/DC is the maximum voltage level allowed to be applied to relay.

When relay output is not triggered (normal state) the NC is shorted with COM, when triggered (active state) NO contact is shorted to COM. When controller is not supplied or supplied with voltage below its minimum level the relay output remains in normal (not triggered) state.

**Transistor outputs**

There are two transistor outputs IO1 and IO2, both outputs has identical electrical structure. When not triggered (normal state) transistor outputs represent high impedance, when triggered (active state) outputs short connected potential to supply minus (GDN). Each output can switch max. 1A DC while connected voltage must be 15V DC or less. The IO1/IO2 are internally protected and automatically switch off if current rise above 1A and automatically restore when current drops below 1A.

**Communication bus**

The communications bus consist of three lines: A, B and cable’s shield (SHLD). Electrically it represents RS485 standard however either the daisy chain structure nor terminating resistors are not required. Free topology of communication bus is allowed, the A/B wires can be laid down using “three”, “star” or any combination of them. It is recommended to use UTP cable for A and B lines however other types of signal cables are accepted as well. The use of shielded cables should be limited to those installation were strong electromagnetic interferences are expected.

The maximum length of cable between communication interface and individual controller or between CPR32-SE network controller (if installed in system) and individual controller, or between communication interface and CPR32-SE network controller must not exceed 1200m.

When longer cable lengths required the UT-3 or UT-4 interfaces can be used. Using two UT-3 unit communication distance can be extended by next 1200m while using UT-4 distance is not limited while UT-4 is connected to any location when computer network is available.

### Connecting readers and extension modules

Access terminals (readers) and extension modules (e.g. XM-2, XM-8) can be connected to controller through CLK and DTA lines. Controller can operate either with Roger access terminals (format RACS) or with any other type of readers which are equipped with Wiegand or Magstripe interfaces. Any type of signal cable can be used for CLK and DTA lines. Each device connected to controller through CLK/DTA lines must have its individual address (0..15) however this rule is not valid for devices which operate with non RACS format (e.g. Wiegand or Magstripe).

Note: Normally the maximum guaranteed cable run between controller and any other device connected through CLK/DTA line is limited to 150m nevertheless in most cases communication will be satisfactory for up to 500m however it is not guaranteed.

For best card reading results controller should be installed on non metal surface. When installed on metal structure the reading range might be reduced up to 50%. This effect can be reduced by placing non metal spacer (min. 10mm thick) between controller and metal surface.

Controller should be installed on at least 0.5m distance from another reader, also both reader should not be aligned along the same geometrical axes.

### Connecting Wiegand and Magstripe readers

Follow schematic drawing below when connecting Wiegand or Magstripe reader to controller. Note, that to prepare the controller for operation with those type of readers you must make relevant setting in PR Master program.

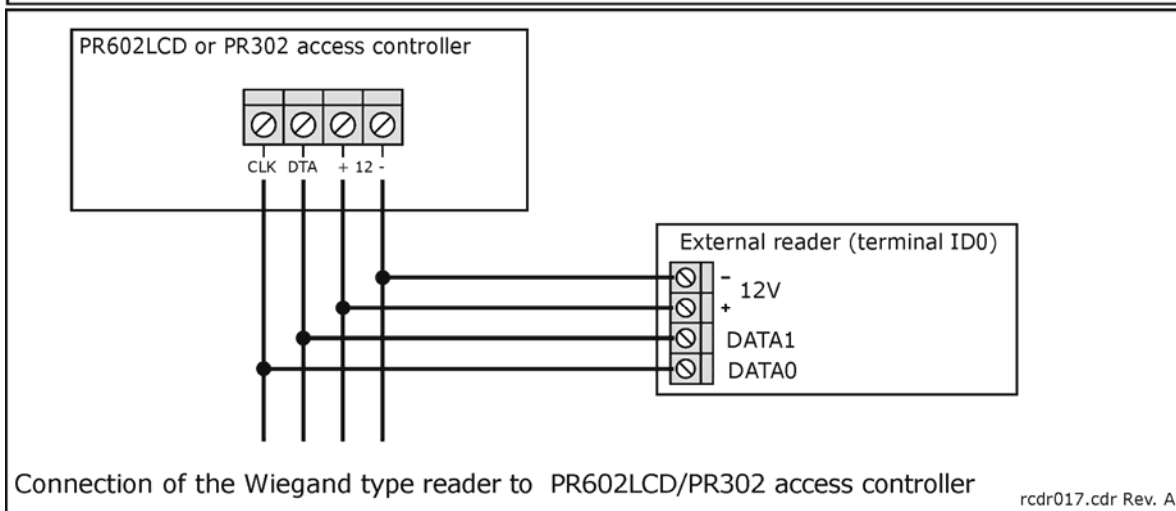
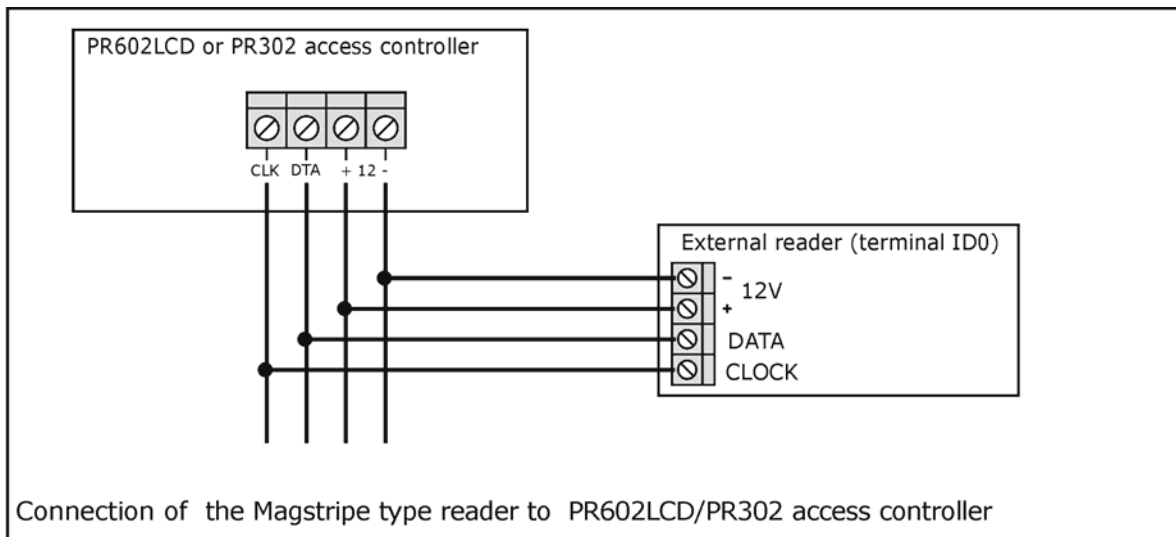

rcdr017.cdr Rev. A

## Memory Reset

The Memory Reset procedure clears all existing data in memory, restores default settings of configuration, enables for enrolment of the new MASTER card/PIN and the new ID number (address) of the controller. There are two methods to enter Memory Reset:

- By means of CLK and DTA line
- By means of programming jumpers available in rear panel of the controller enclosure

The method by use of CLK and DTA lines doesn't requires access to internal space of controller's enclosure.

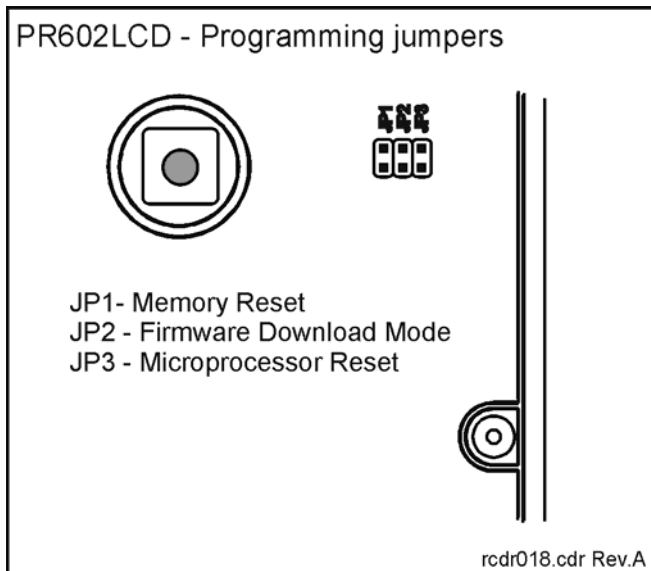

Memory Reset by means of programming jumpers:

- Put jumper on MEMORY RESET contacts and wait till LED OPEN (green) will start blinking
- Remove jumper from MEMORY RESET contacts
- Enter new MASTER PIN and press [#] or if you don't want to program it press [#] key only
- Read any proximity card - this will be a new MASTER card or press [#] to skip this step
- Enter two digits (range 00..00) which will program new ID number (address) for the unit

After this step Memory Rest will be completed and controller returns to normal operations.

Memory Reset by means of CLK and DTA wires:

- Remove all connections from CLK and DTA lines
- Short CLK and DTA lines
- Restart controller (Power off / Power on)
- Remove connection between CLK and DTA lines, LED OPEN will start blinking
- Enter new MASTER PIN and press [#] or if you don't want to program it press [#] key only
- Read any proximity card - this will be a new MASTER card or press [#] to skip this step
- Enter two digits (range 00..00) which will program new ID number (address) for the unit

After this step Memory Reset will be completed and controller returns to normal operations.

Once the Memory Rest is completed controller restores Default (Factory) settings, using MASTER PIN/card you can initially test installation while:

- Single use of MASTER PIN/card triggers REL1 for 4s

- Double use of MASTER PIN/card changes controller's arming mode and switches IO1 output to opposite state.

## Firmware upgrade

During manufacturing process controller is programmed with latest version of firmware, nevertheless it can be later upgraded with newer versions. Roger design team continuously work on enhancements so the new firmware versions are released quite often (every new firmware version is published on [www.roger.pl](http://www.roger.pl)). Our customers are advised to register at web site so Roger will let inform when new versions are ready for download. The new firmware can be downloaded without removal of the controller from live installation. The detailed description of firmware upgrade procedure can be found in *Firmware upgrade.pdf* on [www.roger.pl](http://www.roger.pl).

The new firmware is programmed into the controller by means of communication bus and doesn't require de-installation of the unit from its original location. For firmware upgrade the RogerISP v3 program is required. Once the controller is upgraded it should be fully reconfigured, also it is necessary to update the RACS database which must know what is the current version of controller's firmware (command ...**Networks/Controllers/Commands/Restart controller and verify version..**).

---

Note: Whenever new firmware is uploaded into the unit the PR Master program should be also upgraded to latest available version.

---

Cable connection assignments		
Wire colour	Name	Function
Red	+12V	Power supply plus
Black	GND	Power supply minus, also reference ground for inputs, RS485 and Clock and Data interface
Pink	IN1	IN1 input, internally pulled to supply plus through 5.6kΩ resistor
Blue	IN2	IN2 input, internally pulled to supply plus through 5.6kΩ resistor
White-yellow	IN3	IN3 input, internally pulled to supply plus through 5.6kΩ resistor
Brown	RS485 A	RS485 communication bus, line A
White-green	RS485 B	RS485 communication bus, line B
White	CLK	Interface RACS Clock & Data, line CLOCK
Green	DTA	Interface RACS Clock & Data, line DATA
Yellow-brown	IO1	IO1 transistor output 15V DC/1.0A
Brown-green	IO2	IO2 transistor output 15V DC/1.0A
Violet	REL1-NO	REL1 output, normally open contact, 24V/1.5A rated
Red-blue	REL1-COM	REL1 output, common contact, 24V/1.5A rated
Gray-pink	REL1-NC	REL1 output, normally closed contact, 24V/1.5A rated
Yellow	TAMPER A	Tamper switch, line A, 24V/50mA rated
Gray	TAMPER B	Tamper switch, line B, 24V/50mA rated

<b>Technical specification</b>	
Supply voltage	10-15 VDC
Current consumption	average 100 mA
Anti-sabotage	Isolated contact, NC type, 50mA/24V rated, IP67
Reading distance	UP to 12 cm for ISO card (depends on card type)
Cards	EM 125 KHz (EM4100/4102 compatible)
Distances	Between controller and reader or extension module: max. 150 m Between controller and Communications interface or CPR32-SE network controller: 1200m
Environmental class (according to EN 50131-1)	Class IV, Outdoor-General, temperature: -25°C- +60°C, relative humidity: 0 to 95% (non-condensing)
Ingress protection	IP 65
Dimensions	170 X 110 X 42 mm
Weight	~ 410g
Approvals	CE

<b>Ordering information</b>	
PR602LCD	PR602LCD access controller
RM-2	Relay module with plastic enclosure, the RM-2 offers two relays with one NO/NC contact 1.5A/24V rated, relay contacts are protected by over-voltage components, each relay can be triggered by applying supply plus or minus, the maximum amount of current required to trigger relay is less then 5mA, two LEDs to indicate triggering of relevant relay
RM-2 PCB	RM-2 PCB module without enclosure
XM-2	Input/output addressable extension module with plastic enclosure, digital communication according to RACS Clock and Data protocol, two NO/NC inputs and two relay outputs, each relay offers one NO/NC contact 1.5A/24V rated, relay contacts protected by over-voltage components, two LEDs to indicate triggering of relevant relay
XM-2 PCB	RM-2 PCB module without enclosure
UT-2	RS232-RS485 communication interface
UT-2USB	USB-RS485 communication interface
UT-4	Ethernet-RS485/RS232 communication interface

**Contact**

**Roger sp. j.**

**82-416 Gosciszewo**

**Gosciszewo 59**

**Tel.: +48 (55) 272 01 32**

**Fax: +48 (55) 272 01 33**

**e-mail: [biuro@roger.pl](mailto:biuro@roger.pl)**



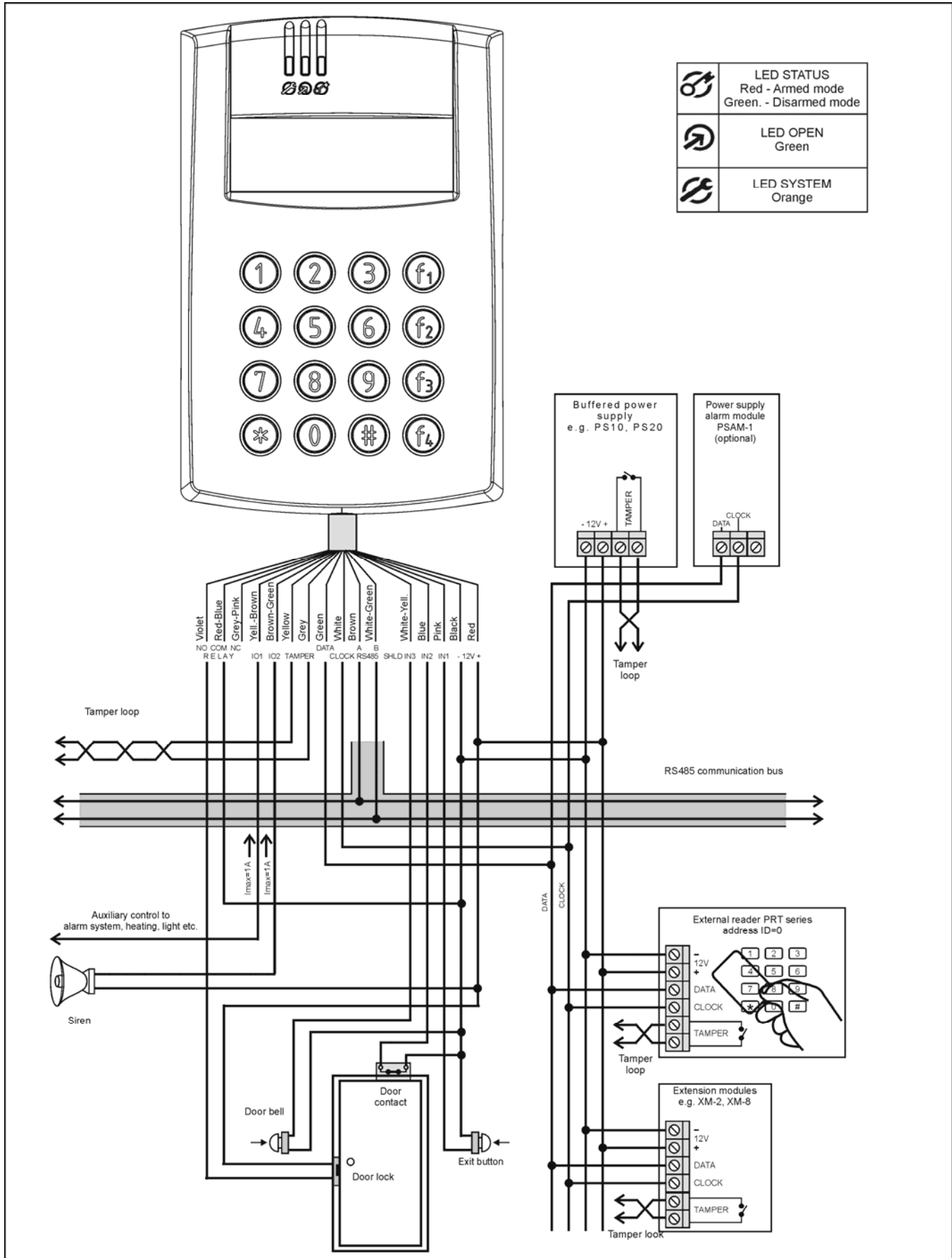

	LED STATUS Red - Armed mode Green. - Disarmed mode
	LED OPEN Green
	LED SYSTEM Orange

Typical installation of PR602LCD access controller (sample only)

rcdr015.cdr Rev.A