

Q60S/R

CONTROL UNIT
FOR SLIDING GATES
230V

EXTERNAL RADIO PANEL

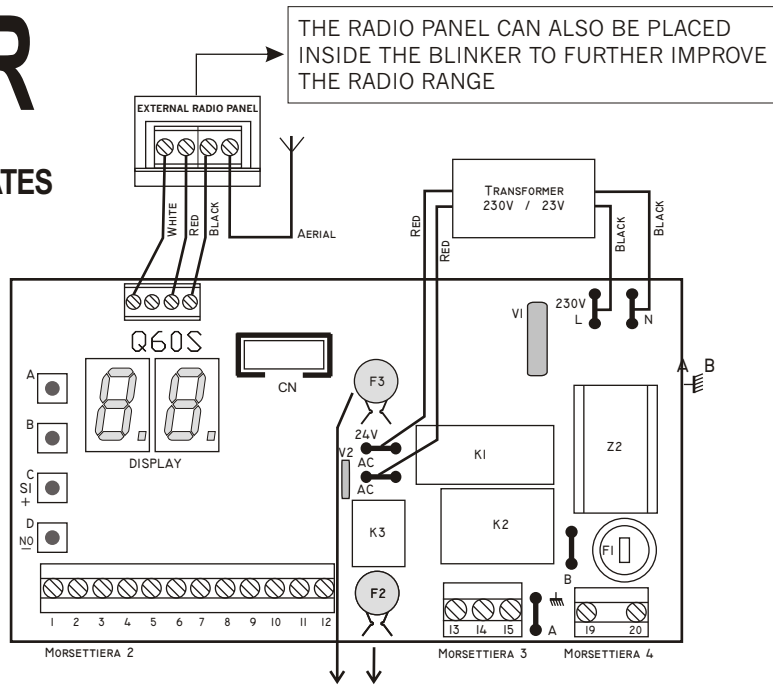

THE RADIO PANEL CAN ALSO BE PLACED INSIDE THE BLINKER TO FURTHER IMPROVE THE RADIO RANGE

CONTROL UNIT COMPONENTS

- A TOP LEVEL MENU BUTTON
- B LOWER LEVEL MENU BUTTON
- C BUTTON TO INCREASE OR CHANGE TO YES (SI)
- D BUTTON TO DECREASE OR CHANGE TO NO
- F1 230V FUSE 5A
- F2 24V FUSE (RESTORABLE) 0,6A
- F3 24V FUSE (RESTORABLE) 1,6A
- DISPLAY 7 SEGMENTS DISPLAY
- M1 RADIO/AERIAL TERMINAL BLOCK
- M2A/M2B CONTROLS AND SAFETY DEVICES TERMINAL BLOCKS
- M3 MOTOR TERMINAL BLOCK
- M4 MAIN POWER TERMINAL BLOCK
- A, B EARTH CONNECTIONS
- MR RADIO UNIT
- CN NOT USED CONNECTOR
- Z2 FILTER
- K1/ K2 MOTOR RELAY
- K3 BLINKER RELAY
- V1 PRIMARY VARISTOR
- V2 SECONDARY VARISTOR

PARAMETERS

B use **button B** to move to next parameter
C use **button C** to **INCREASE** a numeric value or change **NO** to **YES**
D use **button D** to **DECREASE** a numeric value or change **YES** to **NO**
 To save changes and to ensure that they are not lost when power is removed, use **button B** to step through **SU** parameter, the press and hold **button C** until the display reverts to idle display .

RESTORABLE FUSE 24V

IMPORTANT: If a temporary short circuit occurs the fuse will restore itself after few seconds.

In case of a permanent short circuit, cut the main power off, remove the terminal blocks 2A and 2B, wait few seconds and then power the unit again. The fuse will be automatically restored. Find and remove the short circuit cause before plugging the terminal blocks in.

- BUTTON A** → A
Cycle round the top level menu
- BUTTON B** → B
Move from the top level menu to the lower level menu
- BUTTON C** → C
Increase time or change to YES
- BUTTON D** → D
Decrease time or change to NO

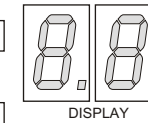

DISPLAY SIGNALS

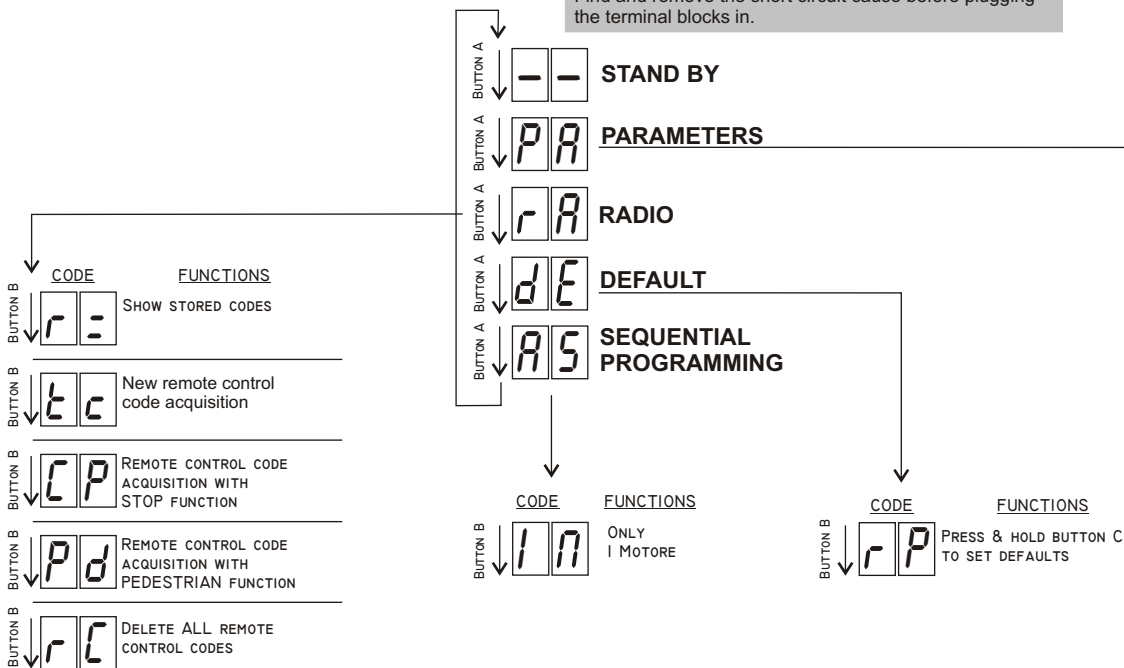
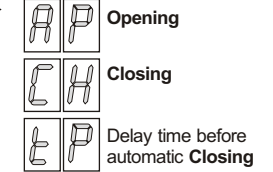

CODE	TIMES	VALUES
NI	MOTOR WORKING TIME 0 → 99	21
FI	MOTOR TORQUE 8 → 19	14
Fr	MOTOR POWER DURING DECELERATION 10 → 19	19
rI	MOTOR DECELERATION TIME 0 → (NI - 2")	6
tP	DELAY TIME BEFORE AUTOMATIC CLOSING 0 → 99	3
Pd	PEDESTRIAN OPENING TIME 0 → 99 (NI, 1)	7
Fn	MAGNETIC LIMITSWITCH	NO

FUNCTIONS	STANDARD DEFAULT VALUES
Press & hold button C to SAVE changes PRESS BUTTON D TO ABANDON CHANGES	
P9 SOFT START	YES
P8 PHOTOCELLS TEST	YES
P7 Motor test	YES
P6 DECELERATION ON	YES
P4 PRE BLINKING	NO
P3 AUTOMATIC CLOSING STEP BY STEP	YES
P2 MULTI OCCUPATION	NO



PROGRAMMING THE RADIO

IMPORTANT: BEFORE PROGRAMMING FOR THE FIRST TIME THE RADIO RECEIVER, DELETE ALL THE RECORDED TEST CODES. SEE FUNCTION  AT THE BOTTOM OF THIS CHAPTER

IN CASE OF TRANSMITTERS WITH DIP-SWITCHES, SET THE MICROSWITCHES TO CREATE A NEW PERSONAL CODE.
(For security reasons avoid to set the microswitches all in OFF or all in ON position).

IN CASE OF HIT TYPE TRANSMITTERS, THE ABOVE MENTIONED PROCEDURE IS NOT NECESSARY BECAUSE EACH TRANSMITTER COMES WITH ITS OWN CODE RANDOM.



DISPLAYING STORED CODES

Press the **button A** repeatedly until the display shows 
Press **button B** until the display shows 
The display will now cycle through each stored code from 01 to 50.



TO ERASE A SINGLE STORES CODE

Press **button D** when the number of the code to be removed is displayed



STORING NEW REMOTE CONTROL CODE

- Press the **button A** repeatedly until the display shows 
- Press **button B** until the display shows 
- Press and hold the remote control button until a dot appears on the display (this means that the receiver is ready to store a new code) and simultaneously press **button C** to store the new code



STORING NEW REMOTE CONTROL CODE with STOP function

- Press the **button A** repeatedly until the display shows 
- Press **button B** until the display shows 
- Press and hold the remote control button until the dot appears on the display and simultaneously press **button C** to store the new code.

STORING NEW REMOTE CONTROL CODE with PEDESTRIAN function

- Press the **button A** repeatedly until the display shows 
- Press **button B** until the display shows 
- Press and hold the remote control button until the dot appears on the display and simultaneously press **button C** to store the new code

DELETING ALL STORED CODES

- Press the **button A** repeatedly until the display shows 
- Press **button B** until the display shows 
- Press and hold **button D** until the display shows 
This indicates that all the codes have been erased

SELF-DIAGNOSIS DISPLAY MESSAGES



Photocell's test error



Fotocellula o
Costa di sicurezza
in apertura



Closing phase photocell
beam interrupted
or wiring fault



Both opening and closing
phase photocell beam
interrupted or wiring fault



Stop pressed
(or open circuit between
terminal 2 & 8)



Limit switch
in opening phase



Limit switch
in closing phase



Pedestrian start signal
(short circuit between
terminal 7 & 8)



Start signal
(short circuit between
terminal 1 & 8)



Radio fob
continuously
transmitting



Motor problem (wiring
fault, obstruction or
torque setting too low)

PROGRAMMING THE Q60S W PARAMETERS

WARNING :

Before proceeding with the control board commissioning, check which kind of limit switch is installed on the motor.

The control board is preset to work with electromechanical limit switches.

 → NO

In case of magnetic limit switch please select parameter:

 → YES

Method 1 = **STANDARD**

Method 2 = **SEQUENTIAL**

Warning:

Before powering up and programming the control unit refer to the wiring scheme and then:

- 1 Check that the motor connections are correct
- 2 Check that the photocell connections are correct

Important:

*If the photocells are not installed in closing phase, you must link terminals 3 and 9.
If the photocells are not installed in opening phase, you must link terminals 4 and 9.*

- 3 Check that the control connections are correct.

Important:

If an emergency stop button is not fitted, you must link terminals 2 and 8.





- 4 Use the motor release key supplied to disengage the electric motor from the mechanical drive; then close the gate and re-engage.
- 5 Power the control unit up

STANDARD PROGRAMMING PROCESS (Method 1)

- a) Give a **START** signal (terminal 1 and terminal 8).
After an opening movement of about 240mm, the deceleration phase will start (since the control board is pre-adjusted for an opening of 2,50m). The motor will wait about 3 seconds and after that will start again with the closing phase.
- b) Give a **START** signal to verify which functions and times are not suitable with the installation and take note.
- c) Enter the programming phase through the **buttons A and B** to reach the wished parameter
- d) Use the buttons **C and D** to change or confirm every single parameter
- e) **IMPORTANT:** save the changes by selecting the parameter  and pushing the **button C**.





Example:

Increase the motor working time by 5 seconds

With the switched on control board, ensure that the display shows: → --
Press **button A** until the display shows → 
Press **button B** until the display shows → 
Wait until the display shows → 
Press 5 times the **C** until the display shows → 
Press **button B** until the display shows → 
Press the button C for some seconds until the display shows → --
The motor working time has been increased from 21 to 26 seconds

SEQUENTIAL PROGRAMMING (method 2)

SLIDING GATE SEQUENTIAL PROGRAMMING

- a) Press **button A** (steps through the top menu) until the display shows 
- b) Press **button B** (steps through the sub-menu) until the display shows 
- c) Give a **START** signal: the leaf starts opening and the display shows 
- d) Wait until the leaf has done the 90% of the opening cycle and then give another **START** signal: the display shows  and the deceleration phase begins.
- e) When the opening phase has been completed (**OPENING LIMIT SWITCH**) and the display shows , the control board has stored the opening and deceleration times and starts calculating the "**stay open**" (pause) time
- f) At the reaching of the desired pause time, give another **START** impulse. The control board has stored the "**stay open**" time and the gate starts the closing cycle.
- g) When the closing cycle has completely finished, till the complete closure of the gate, the control unit automatically exits from the sequential programming process and all the working times have been saved.

SPECIAL FUNCTIONS



AUTOMATIC CLOSING FUNCTION

When set to YES ("SI"):

- an impulse during the opening phase will stop the motors until another impulse is received
- an impulse during the closing phase will stop and reverse the motors

When set to NO, the step-by-step operation is active:

- 1st impulse starts the **opening phase**
- 2nd impulse stops the **opening phase**
- 3rd impulse starts the **closing phase**



MULTI-USER FUNCTION

when set to YES ("SI"):

The control unit will not accept any command during the opening phase

TERMINAL BLOCK CONNECTIONS
All the connections must be done without power supply.

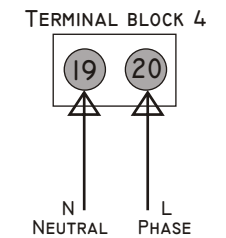
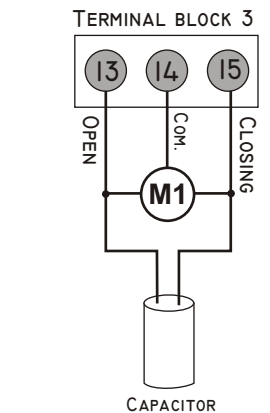
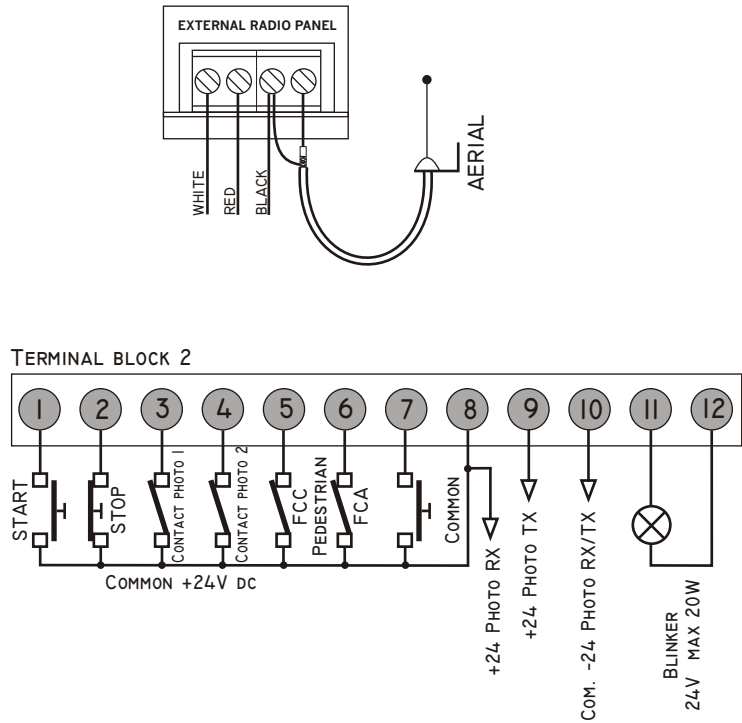

EARTH TERMINAL BLOCK CONNECTIONS

Connect the yellow/green motors cable to earth terminal **A** .
Connect the yellow/green network cable to earth terminal **B**.

TERMINAL BLOCK 2 CONNECTIONS

1-8	Start control normally open (NA) for button, key selector , radio receiver or Timer clock connection. The Start control starts the programmed running cycle.
2-8	Stop control normally closed (NC). Emergency button. When pressed the gate stops immediately. In Opening phase and Break-time: at the first impulse the gate closes. In Closing phase: at the first impulse the gate opens. If, temporarily, the Stop contact is not used, link terminal 2 with terminal 8.
3-8	Input of one safety photocell in closing phase. Input of safety rubber edges and of safety photocell in closing phase. Input of several safety photocells in closing phase. The receiver contacts must be connected in series. Normally closed (NC). In opening phase: does not work In closing phase: Stop, break-time for 2 seconds, opening phase again. If, temporarily, the photocell contacts are not used, link terminal 3 with terminal 9.
3-9	Input only for safety rubber edges in closing phase. The contacts must be connected in series if there is more than one safety rubber edge. Normally closed (NC). In opening phase: does not work. In closing phase: Stop, break-time for 2 seconds, opening phase again.
4-8	Input for safety photocells in opening phase (for sliding gate). Normally closed (NC). In opening phase: Stops and changes direction for 3 seconds In closing phase: does not work If you also want to connect the safety rubber edges, you must connect in series their contacts with the photocell ones. If, temporarily, the photocell contacts are not used, link terminal 4 with terminal 9.
4-9	Input safety rubber edges in opening phase (for sliding gate). Normally closed (NC). In opening phase: Stops and changes direction for 3 seconds In closing phase: does not work Using more than one safety rubber edges, the contacts must be connected in series.
5-8	Limit switch input in closing phase.
6-8	Limit switch input in opening phase.
7-8	Pedestrian start input. Normally open (NA). Only one leaf start to open
8-10	Output for photocell receiver power supply. Output for extra 24V dc accessories power supply. With all Standard accessories included 100 mA are still available for extra accessories.
9-10	Output for photocell transmitter power supply.
11-12	Blinker intermittent output. 24V 20W max.

TERMINAL BLOCK 3 CONNECTIONS

13- 14-15	Motor M1- output The motor is assembled to be fixed on the right side of the gate (looking from inside). If you need to fix it on the left side of the gate and the motor has electromechanical limit switch system, you have to swap motor wires 13 with 15 and limit switch wires 5 with 6. Capacitor between plugs 13 and 15. If you need to fix it on the left side of the gate and the motor has magnetic limit switch system, you have to swap motor wires 13 with 15 and keep unchanged the limit switch wires. PLEASE PAY ATTENTION TO REVERSE THE MAGNET SUPPORTS. Capacitor between plugs 13 and 15.
------------------	--

TERMINAL BLOCK 4 CONNECTIONS

19-20	Power input 230-240 Vac - 50/60 Hz. (19=Neutral - 20=phase)
--------------	---

WIRING SCHEME FOR THE Q60S CONTROL UNIT

1 START

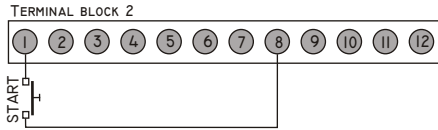

2 PEDESTRIAN START

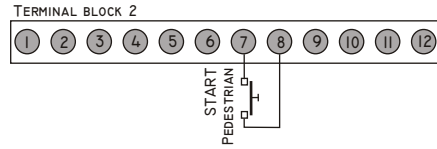

3 PERMANENT START COMMAND WITH TIMER

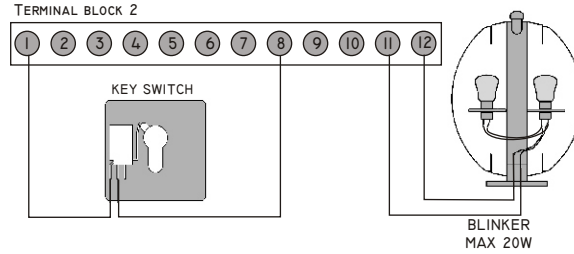
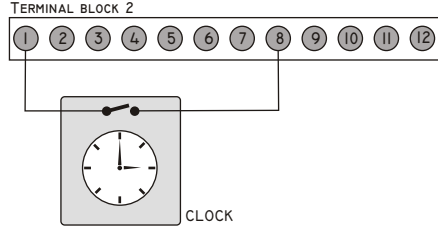

4 EMERGENCY STOP BUTTON

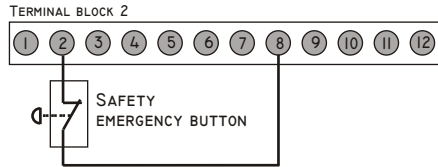

N.B.: Link terminals 2 and 8 if an emergency STOP button is NOT USED

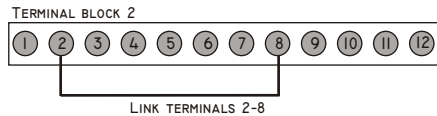

5 MOTOR AND LIMIT SWITCH ELECTROMECHANICAL

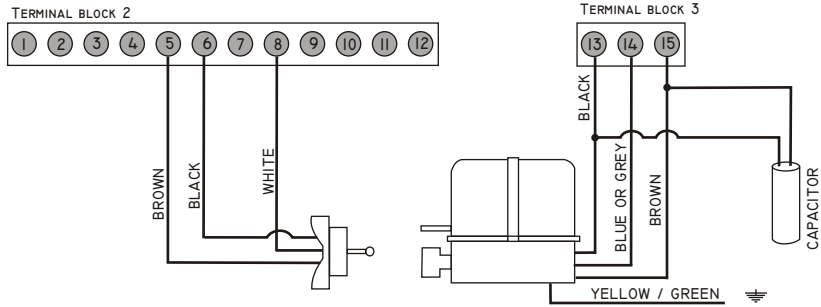

IF IT IS MOUNTED ON THE LEAF-HAND SIDE (looking the inside)
TO INVERT WIRE 13 WITH WIRE 15 END WIRE 5 WITH WIRE 6

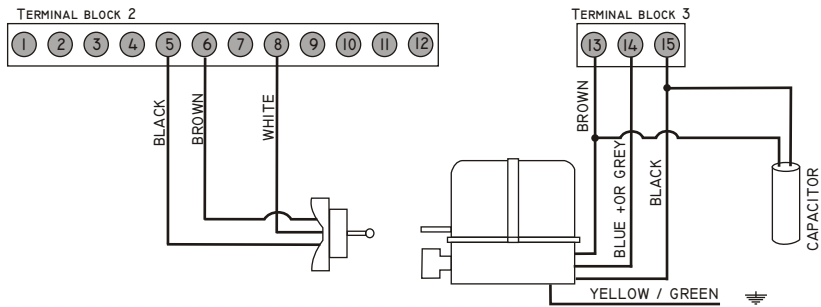

MOTOR AND MAGNETIC LIMIT SWITCH WIRING FOR MOTOR FIXED ON THE RIGHT SIDE OF THE GATE (looking from inside)

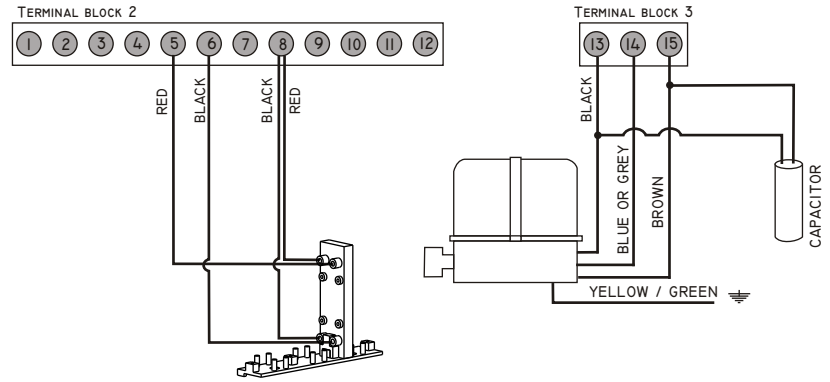

MAGNET SUPPORTS POSITION ON THE RACK IN CASE OF MOTOR FIXED ON THE RIGHT SIDE OF THE GATE AND CLOSING TO THE LEFT (looking from inside)

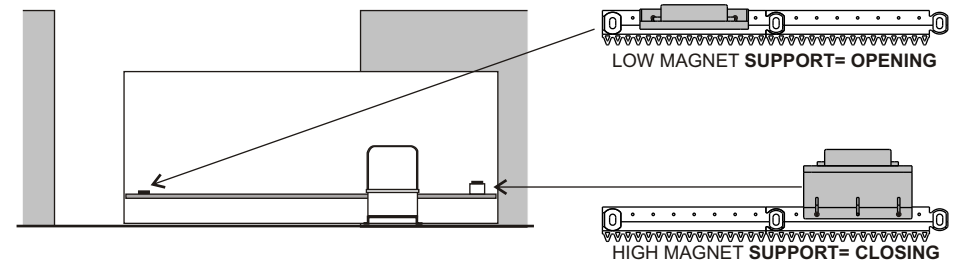

N.B. THE HIGH MAGNET SUPPORT HAS ALWAYS TO BE USED FOR THE CLOSING MOVEMENT

IN CASE OF MOTOR FIXED ON THE LEFT SIDE OF THE GATE (looking from inside)

SWAP MOTOR WIRE 13 WITH THE 15 AND CHANGE THE POSITION OF THE MAGNET SUPPORTS

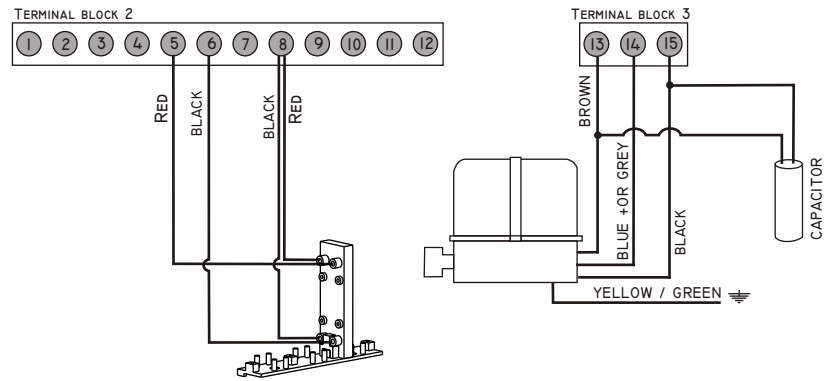

MAGNET SUPPORTS POSITION ON THE RACK IN CASE OF MOTOR FIXED ON THE LEFT SIDE OF THE GATE AND CLOSING TO THE RIGHT (looking from inside)

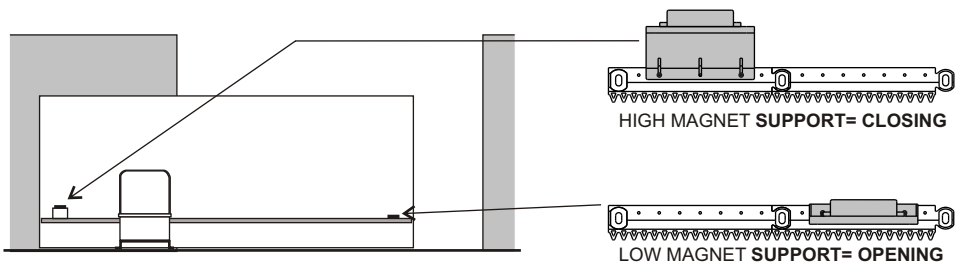

N.B. THE HIGH MAGNET SUPPORT HAS ALWAYS TO BE USED FOR THE CLOSING MOVEMENT

MOTOR AND LIMIT SWITCH WIRING IN CASE OF USE WITH ROAD BARRIER

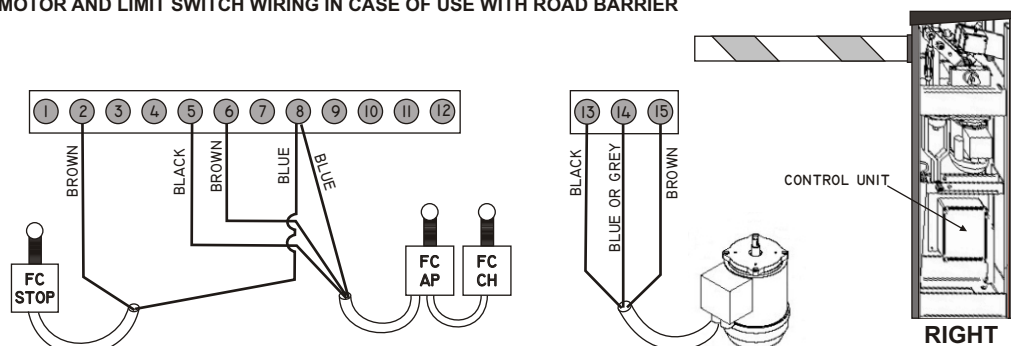

N.B. : TO REVERSE THE OPENING SIDE PLEASE SEE THE BARRIER INSTRUCTION MANUAL

6 CONNECTING PHOTOCELL IN CLOSING PHASE

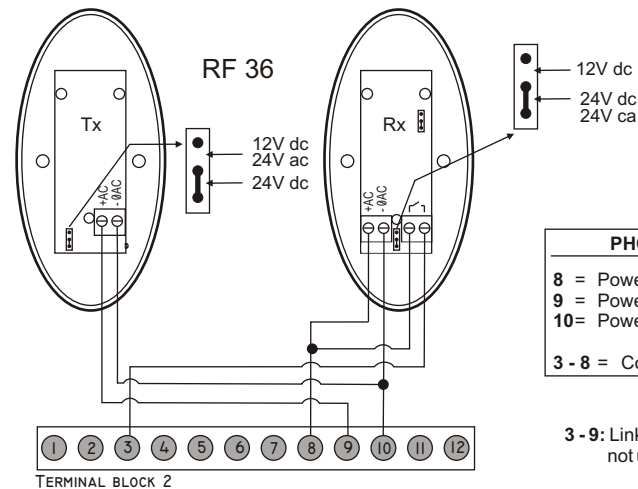

PHOTOCELLS CONNECTIONS

- 8** = Power supply + PHOTO RX
- 9** = Power supply + PHOTO TX
- 10** = Power supply - COM. PHOTO TX/RX
- 3 - 8** = Connections photocells

3 - 9: Link terminals **3** and **9** if the photocells are not used in the closing phase.

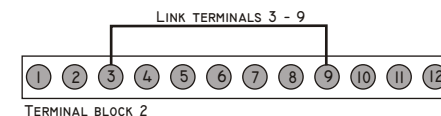

CONNECTING PHOTOCELL IN OPENING PHASE

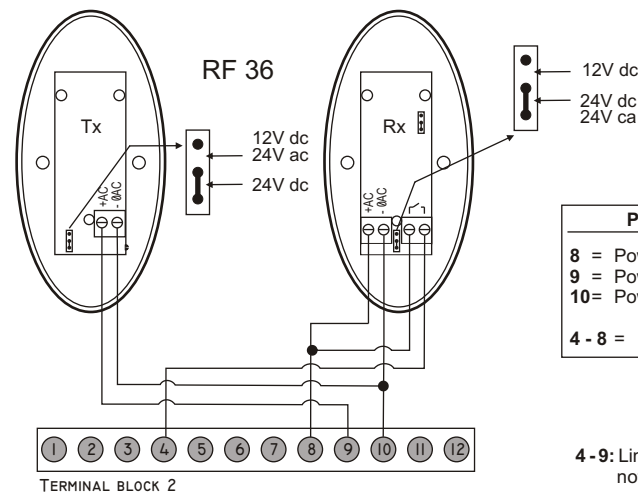

PHOTOCELLS CONNECTIONS

- 8** = Power supply + PHOTO RX
- 9** = Power supply + PHOTO TX
- 10** = Power supply - COM. PHOTO TX/RX
- 4 - 8** = Connections photocells

4 - 9: Link terminals **4** and **9** if the photocells are not used in the opening phase.

