

# SWING

Automation system for counterweight balanced  
(up and over) garage doors Technical Installation Manual

# 1. WARNINGS AND GENERAL SAFETY INSTRUCTIONS

This manual contains important safety information.

An incorrect installation or an improper use may cause serious damages to persons or objects.

Read this manual carefully and completely. Pay particular attention to the sections marked by the symbol: 

This indicates that risk to personal injury may occur if not adhered to.

Store this manual safely for future use.



**Always disconnect main power supply before operating in the automatic gate.**



**Make sure that the earth system is perfectly working and always connect the automatic gate to it.**

The installation of automatic gates and doors must fully comply with the requirements set forth in 2006/42/EC Directive, with particular reference to EN 12445 and EN 12453 standards.

The final connection to the electrical mains, testing and start-up of the automation must be performed by skilled and qualified personnel (professional gate installers), who is responsible for carrying out the risks analysis and verifying the compliance of the system with the current safety standards.

This product is exclusively designed and manufactured for the intended use specified in this manual.

Any other use than stated could compromise the integrity and the safety of the product and therefore is strictly prohibited.

The automation is designed to move driveway gates and not intended to be used for any other purpose.



**Do not let children play with the radio transmitters and any other device which could accidentally start the gate automation.**

Use exclusively original parts by manufactured by Proteco for maintenance.

Do not carry out any alteration on the components of the automatic gate.

Proteco SRL will not accept liability for any components and/or additional devices used in-conjunction with the automation that has not been produced exclusively by Proteco.

## CE COMPLIANCE DECLARATION

**Manufacturer:** PROTECO S.r.l.  
**Address:** Via Neive, 77 – 12050 Castagnito (CN) – ITALIA  
declares that  
**The product type:** SWING Electromechanical gear motor for up and over balanced garage doors  
**Models:** SWING, SWING C  
**Accessories:** E102/C, E102/L, E101

Is built to be integrated into a machine or to be assembled with other machinery to create a machine under provisions of 2006/42/EC Machinery Directive, with reference in particular to the following requirements: 1.1.2, 1.1.3, 1.1.5, 1.2.1, 1.2.2, 1.2.3, 1.2.4.1, 1.2.6, 1.3.1, 1.3.4, 1.3.7, 1.3.8.2, 1.3.9, 1.4.1, 1.4.2.1, 1.4.2.2, 1.5.1, 1.5.4, 1.6.1, 1.6.2, 1.6.3, 1.6.4, 1.7.1, 1.7.3, 1.7.4, 1.7.4.1, 1.7.4.2, 1.7.4.3.

It complies with the essential requirements of EEC Directives:

**2006/95/CE**      **Low Voltage Directive**  
**2004/108/CE**    **Electromagnetic Compatibility Directive**

It complies with the essential requirements of EEC Directives:

EN 12453, EN 12445, EN 12604, EN12605, EN 13241-1  
EN 55014-1, EN 55014-2  
EN 60335-1, EN 60335-2-103  
EN 61000-3-2  
EN 61000-3-3

The manufacturer also declares that the start-up of the machinery is not permitted unless the machine, in which the product is incorporated or of which is becoming a component, has been identified and declared as conformed to 2006/42/EC Machinery Directive.

Castagnito, September 14<sup>th</sup> 2014

Angela Gallo

*Angela Gallo*  
C.F.O.

## 2. PRODUCT DESCRIPTION AND INTENDED USE

Il motoriduttore SWING è stato studiato per automatizzare porte da garage basculante a contrappeso di tipo residenziale. Qualsiasi altro uso da quello descritto è da considerarsi improprio e vietato.

Tutti i modelli garantiscono il blocco meccanico della porta con un sistema di ingranaggi irreversibile; non è pertanto necessario installare alcun tipo di serratura.

In caso di black-out il motoriduttore può essere sbloccato manualmente dall'interno del garage.

### 2.1 TECHNICAL SPECIFICATIONS

	SWING
Power Supply	230V ~ 50Hz
Current	1.0 A
Moto Power	300 W
Thermic Protection	140°C
Capacitor	10µF
Motor Thrust	645 Nm
Class IP protection	54
Revolutions (speed)	1400 rpm
Opening time	18"
Maximum door surface	8 m <sup>2</sup>
Working temperature range	- 20°C / +50°C
Duty cycle	50%

### DIMENSIONS

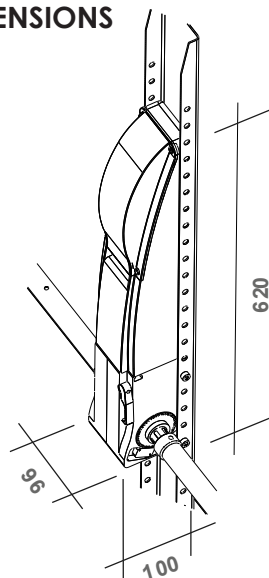

### 2.2 Pack Contents

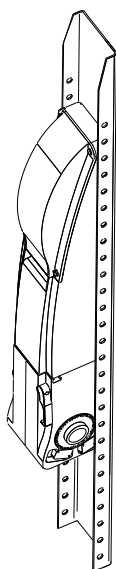

#### SWING C

Gearmotor with release system  
Control panel  
+ Base plate 1.2m  
+ Limit switch system

### 2.3 Optional Accessories

#### E 101

Kit for manually release form outside

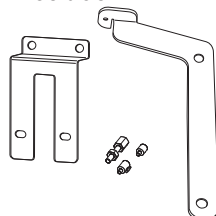

#### E 102/L

Set of telescopic arms and brackets for lateral fixing on door

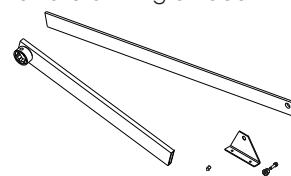

#### E 102/C

Set of telescopic arms and brackets for CENTRAL fixing on door

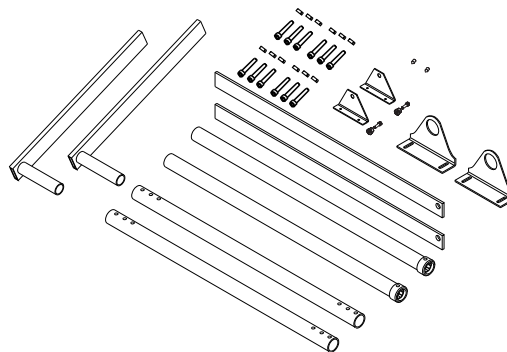

## 3. INSTALLATION

### 3.1 Preliminary Checks

Before the installation, to ensure correct working of the automation, please check the followings:

- Make sure the door can be easily moved manually, without frictions or clinging
- Check the weight, dimensions and type of the door is appropriate to this type of automation
- Ensure the door opens smoothly without skids
- Check correct balancing and condition of the door

Any lack or incorrect movement of the door must be fixed before installing the automation system.

### 3.2 Electrical Set-up

#### 3.2.1 STANDARD INSTALLATION

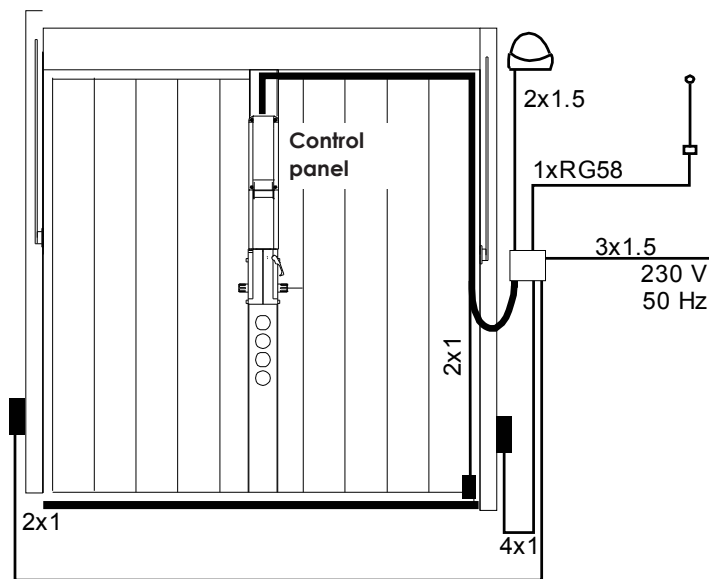

#### 3.2.2 ELECTRICAL CABLES SPECIFICATIONS

Use the following cables are required for a correct electrical set-up:

- |            |                            |
|------------|----------------------------|
| 3 x 1.5    | for electrical mains 230V  |
| 2 x 1.5    | for flashing light         |
| 1 x RG58 f | or external aerial         |
| 2 x 1      | for transmitting photocell |
| 4 x 1      | for receiving photocell    |
| 2 x 1      | for safety edge            |

**Note:** The cables required the electrical set-up (not included in the pack) may vary according to quantity and type of devices installed.

### 3.3 Gear motor Installation

Fix the base plate on the door according to the type of doors and measurements as shown here below.

- a) Unlock any kind of door blocking system
- b) Find the door's height dimension H by door type (Fig. 1, 2 and 3).
- c) Cut the base plate (from the side where there are no holes on the edge) according to the H dimension.
- d) Fix the base plate in the middle of the door (in case of single motor installation) or on the door's edges (in case of twins motor installation) and arrange a solid fastening. Please refer to **3.4.1** and **3.4.2** sections.
- e) Fix the gear motor to the base plate using the four M8x20 screws supplied; make sure that the transmission shaft is from 10 to 15 cm lower than the pivoting point of the door (Fig. 4).  
In case of heavy doors or garage doors with pedestrian shutter in the middle you need to install two motors, one of each edge of the door (Fig. 5).

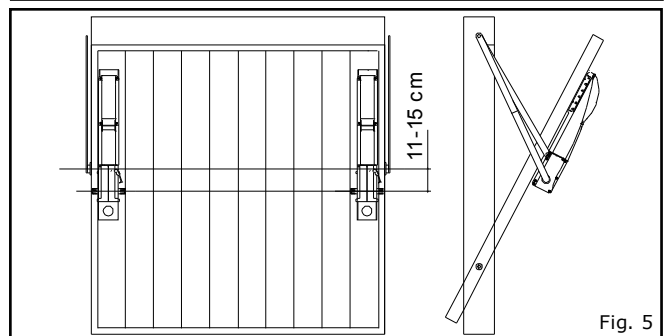
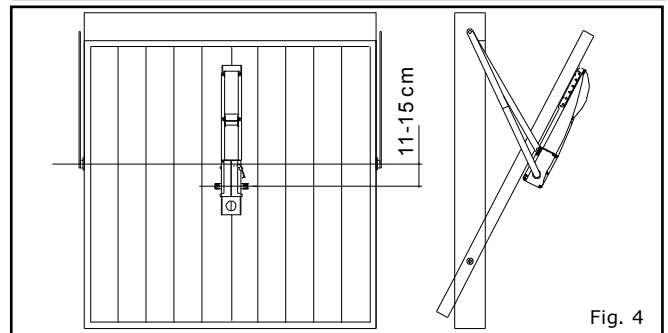
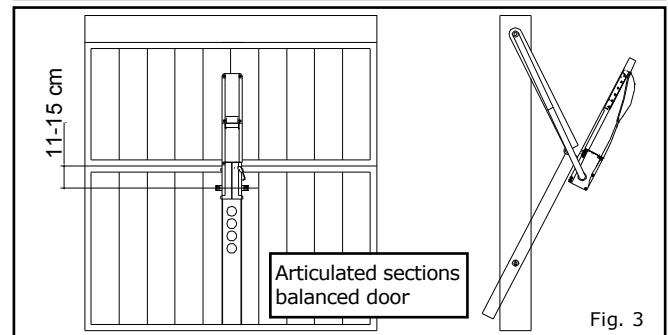
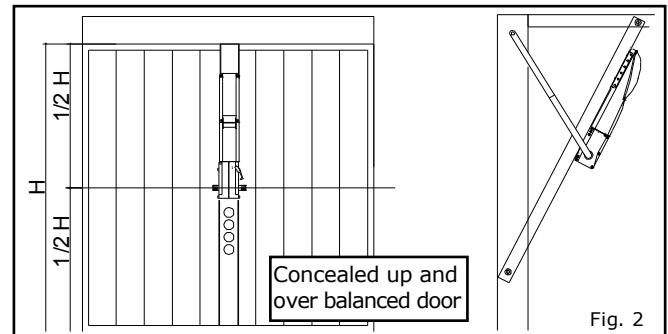
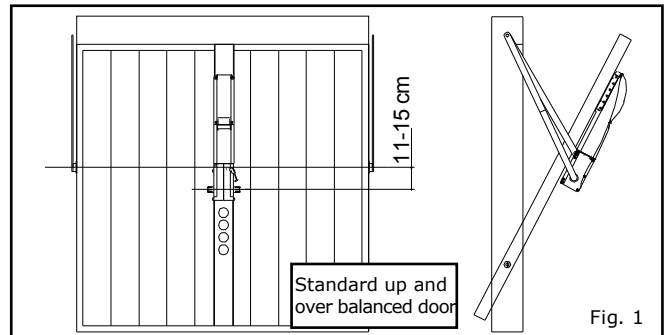

### 3.4 Installing the transmission arms

#### 3.4.1 Installing CENTRAL transmission arms set E102/C (Optional purchase)

- Fix the transmission arms with toothed ring onto the drive shaft and fasten with the two M8x8 grub screws (Fig. 6)
- Get the L arms in to the triangle-shaped brackets with plastic ring (Fig. 7)
- Join the L arms to the toothed ring arms by the supplied coupling pipes (Fig. 8)
- Fix the triangle-shaped brackets to the doors with the supplied screws; make sure that bushings are aligned with the drive shaft (Fig. 9)
- Insert the flat arms ("swords") 35x5 in to the L arms (Fig. 10). The holes must be on the upper side and pointing towards the door.
- Fix the flat arms ("swords") directly to the upper pivots of the door's brackets (Fig. 16). If dimensions or the kind of door don't allow direct fixing on the pivots, please use the supplied anchoring brackets (Fig. 11) and fix them at the same height of the pivot points of the door (Fig. 12)
- Fasten the arms by piercing 12 holes as shown in the picture and fixing the 12 through screws M6x40 and self-locking nuts (Fig. 13).

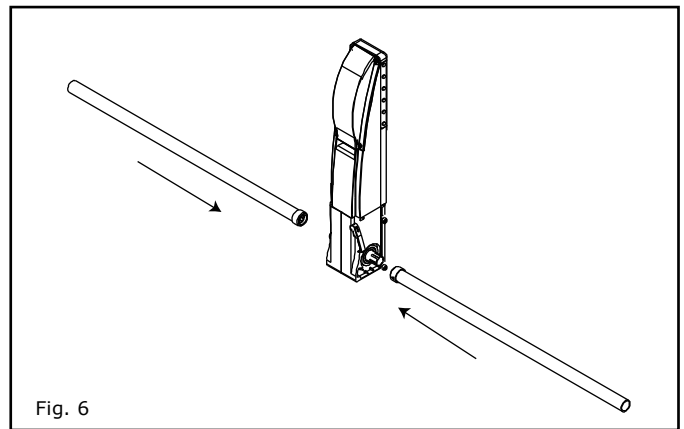

Fig. 6



Fig. 7

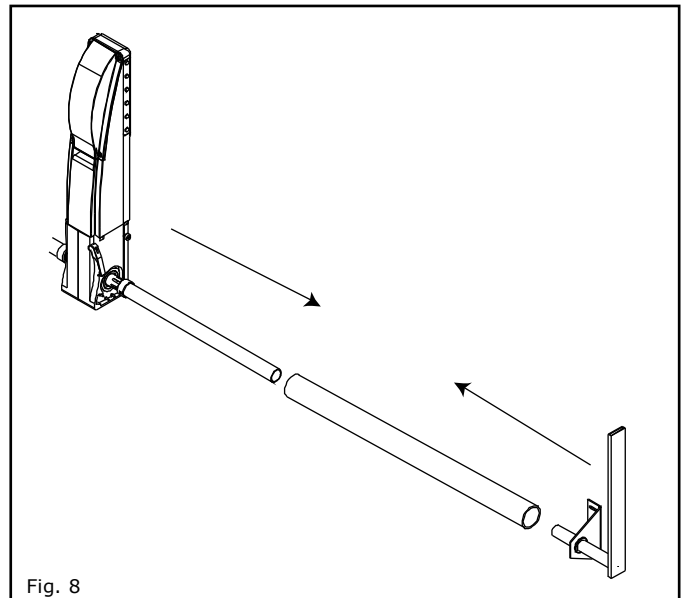

Fig. 8

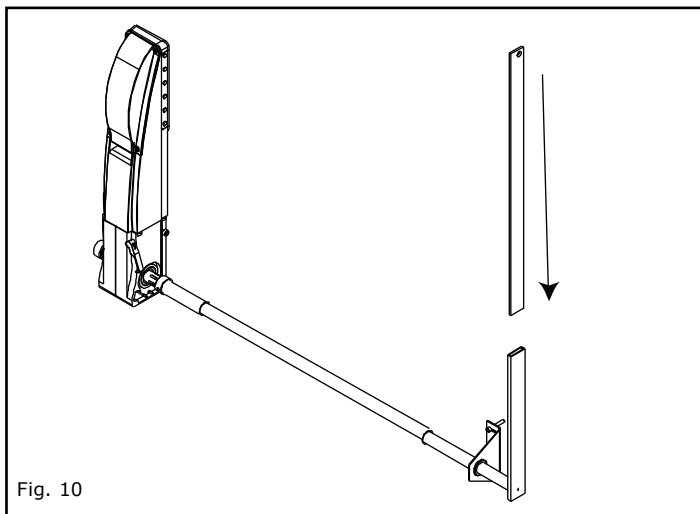

Fig. 10

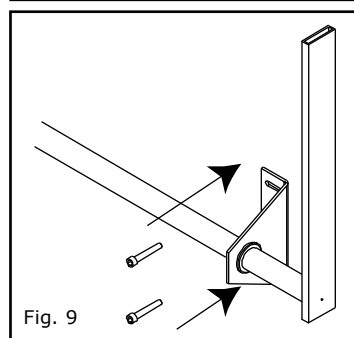

Fig. 9

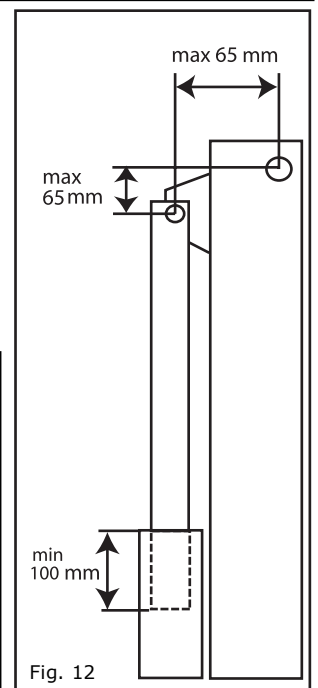

Fig. 12

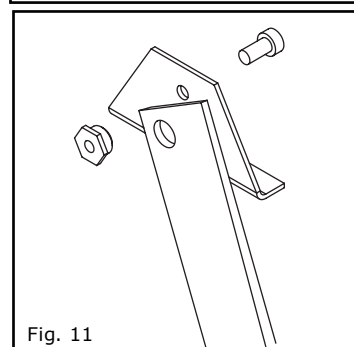

Fig. 11

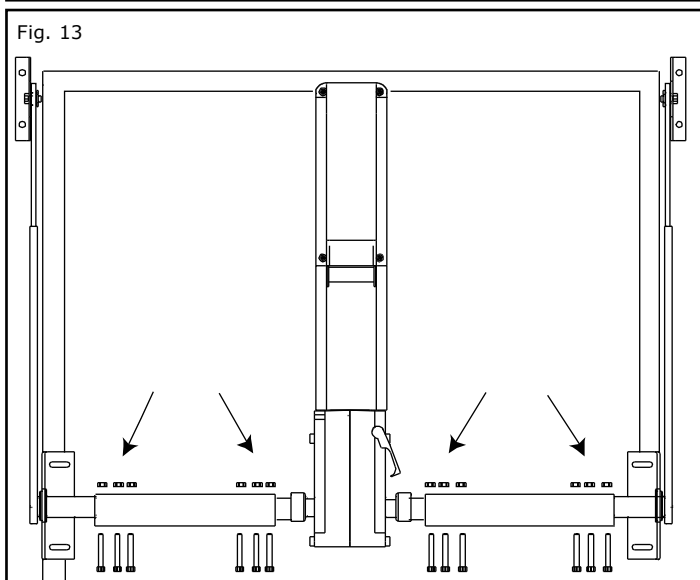
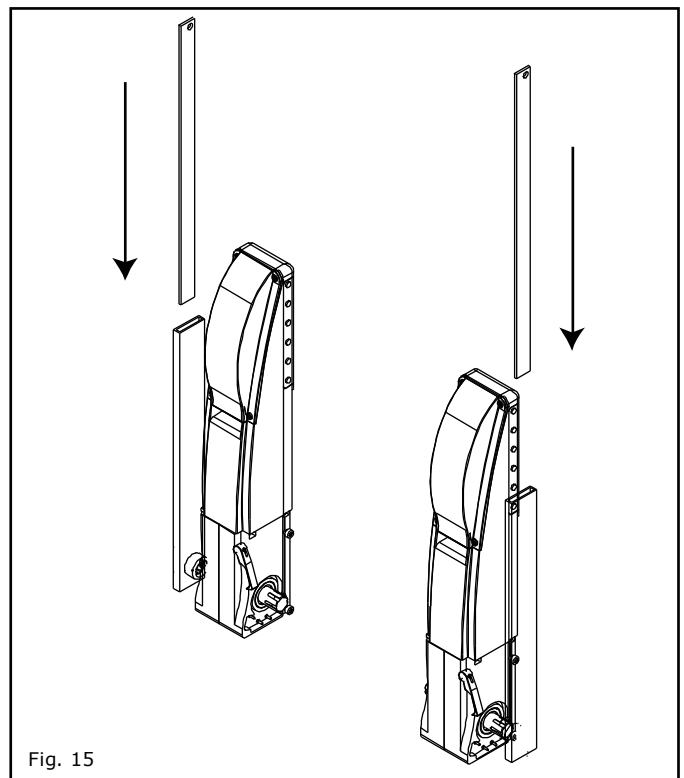
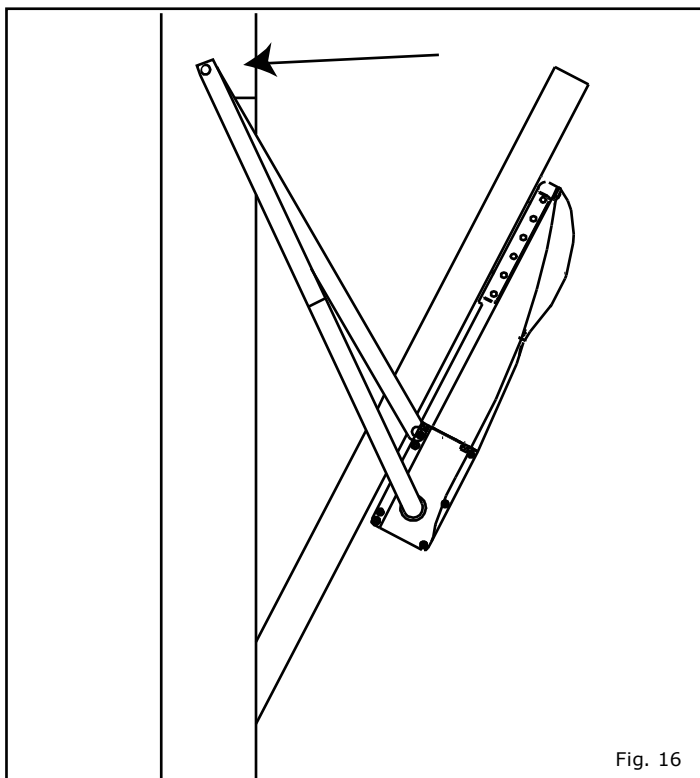
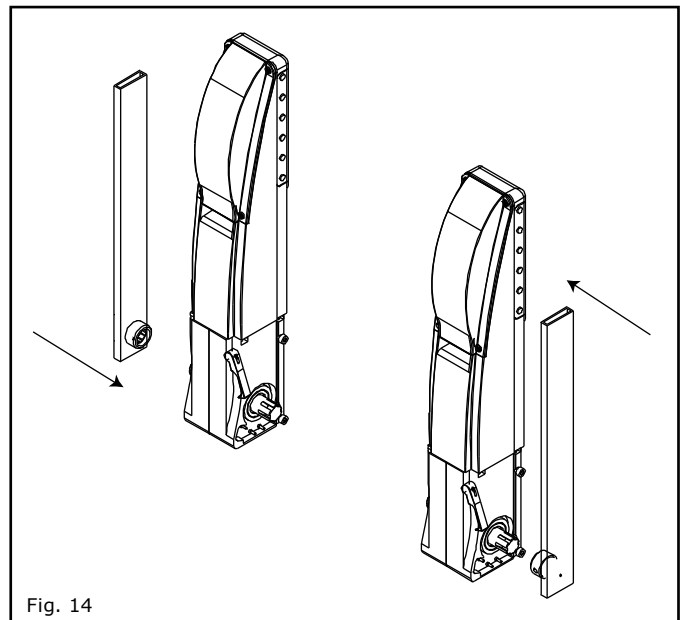

Fig. 13

### 3.4.2 Installing LATERAL transmission arms set E 102/L (Optional purchase)

- a) Fix the toothed ring arm onto the drive shaft and fasten it with the grub screw M8x8 (Fig. 14).  
In case of twin motor installation, repeat procedure on the opposite side.
- b) Insert the flat arms ("swords") 35x5 in to the toothed ring arm (Fig.15)
- c) Fix the flat arms ("swords") directly to the upper pivots of the door's brackets (Fig. 16).  
If dimensions or the kind of door don't allow direct fixing on the pivots, please use the supplied anchoring brackets (Fig. 11) and fix them at the same height of the pivot points of the door (Fig. 12)



## 4. ELECTRICAL WIRING

Wire motor and limit switches as per below schemes:

MOTOR WIRING

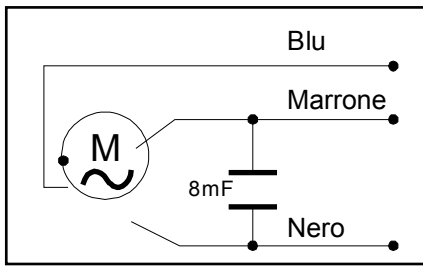

LIMIT SWITCHES WIRING

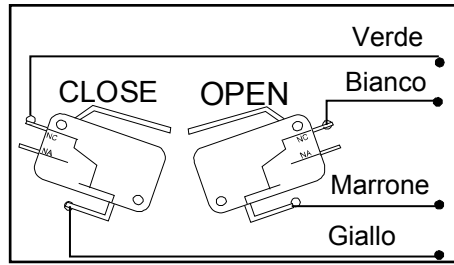

Insert electrical cables into the control panel's case. Please follow the control panel's instruction manual to proceed with the correct cable wiring and programming.

## 5. ADJUSTING LIMIT SWITCHES

- Give the control panel an closing command.
- When the door reaches the closed position give the control panel a Stop command.
- Install the cam ring on the driving shaft, pay attention that pin (D) wouldn't get stuck between the two micros.
- Rotate the ring (B) anti-clockwise so that pin (D) can activate the closing micro-switch (E).
- Fasten the grub screw (C) to fix the ring on the drive shaft in the required position.
- Place the screw (A) about 17-18 clockwise away from pin (D).
- Give the control panel an opening command and check the correct opening position of the door.
- If the door doesn't stop in the correct open position move screw (A) one or more holes backward/forward

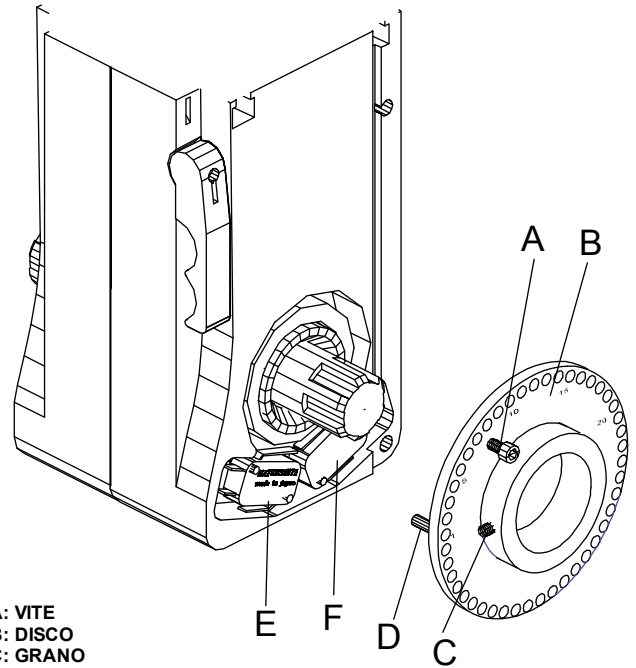

- A: VITE  
B: DISCO  
C: GRANO  
D: PIOLO  
E: MICRO DI CHIUSURA  
F: MICRO DI APERTURA



## 6. INSTALLING THE MANUAL RELEASE SYSTEM FROM OUTSIDE 101

(Optional)

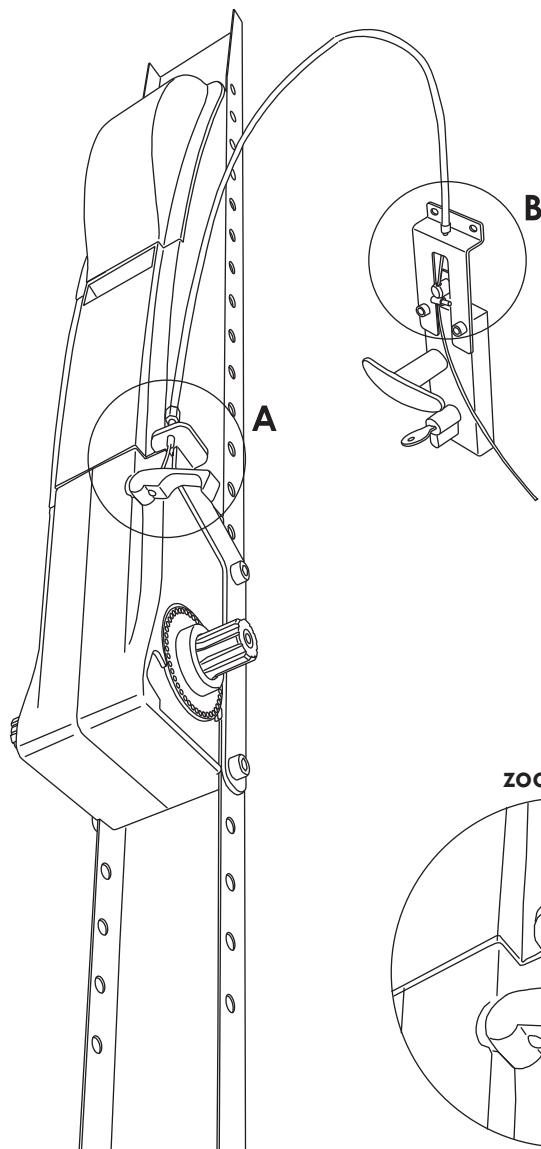

- 1) Unlock motor moving the handle.
- 2) Insert the steel wire in the eyelet on the motor carter (zoom **A**)
- 3) Get the steel wire into the black sheath.
- 4) Drive the sheath and the wire to the point where the pulling system will be fixed.
- 5) When placing the sheath and the wire make sure it makes wide and reasonable bends as shown in the picture.
- 6) Check the limit of the sheath is close to the motor (hold the sheath with one hand and straighten the wire out with the other hand).
- 7) Fix now the pulling system to the frame.
- 8) Cut the sheath accordingly.
- 9) Fasten the wire to the pulling system.
- 10) Adjust wire's pulling by its regulator.

zoom A

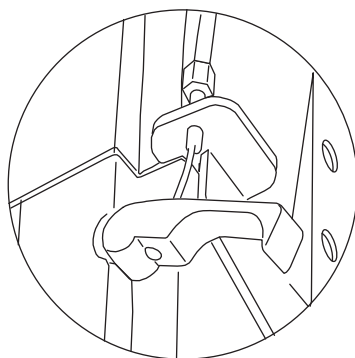

zoom B

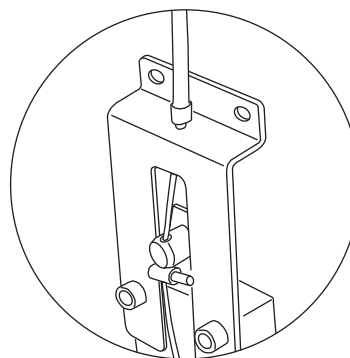

## 7. TESTING THE AUTOMATION AND START UP

Power the system and proceed with a careful checking of the gear motor working, please pay particular attention to safety devices connected to the automation and to the emergency manual release systems.

Place the cover on the motor and screw it.

Hand over this instructions manual to the end user and demonstrate the correct use of the automation and how to release the motor for manual operation of the gate in the event of power cuts.

## 8. RELEASE PROCEDURE FOR MANUAL OPERATION



**Always cut the main power of the system during the release and re-locking procedure to avoid any accidental activation of the door.**

- 1) Cut off main power to motor
- 2) Rotate the handle as shown in the beside picture
- 3) Open the door manually and secure it so that it won't move (for example because of a gust of wind) or fall on people and objects
- 4) Restore power supply, give a Start command to the automation and move the release handle back to its original position.

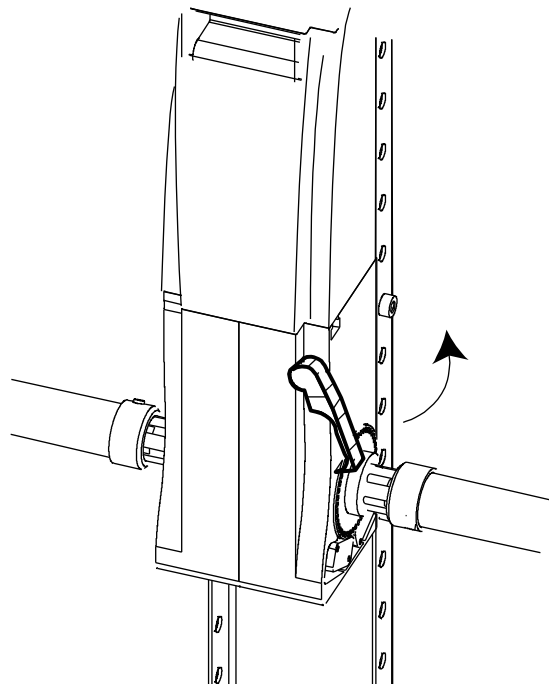

## 9. MAINTENANCE

Effettuare almeno semestralmente la verifica funzionale dell'impianto con particolare attenzione ai dispositivi di sicurezza e di sblocco e alle parti meccaniche in movimento.

## 10. DISPOSAL



**Do not pollute the environment**

Alcune parti di questo prodotto possono contenere sostanze inquinanti. Some components may contain polluting substances. Ensure materials are passed to THE authorised municipal collection facilities.

## 11. EXPLODED VIEW DRAWING

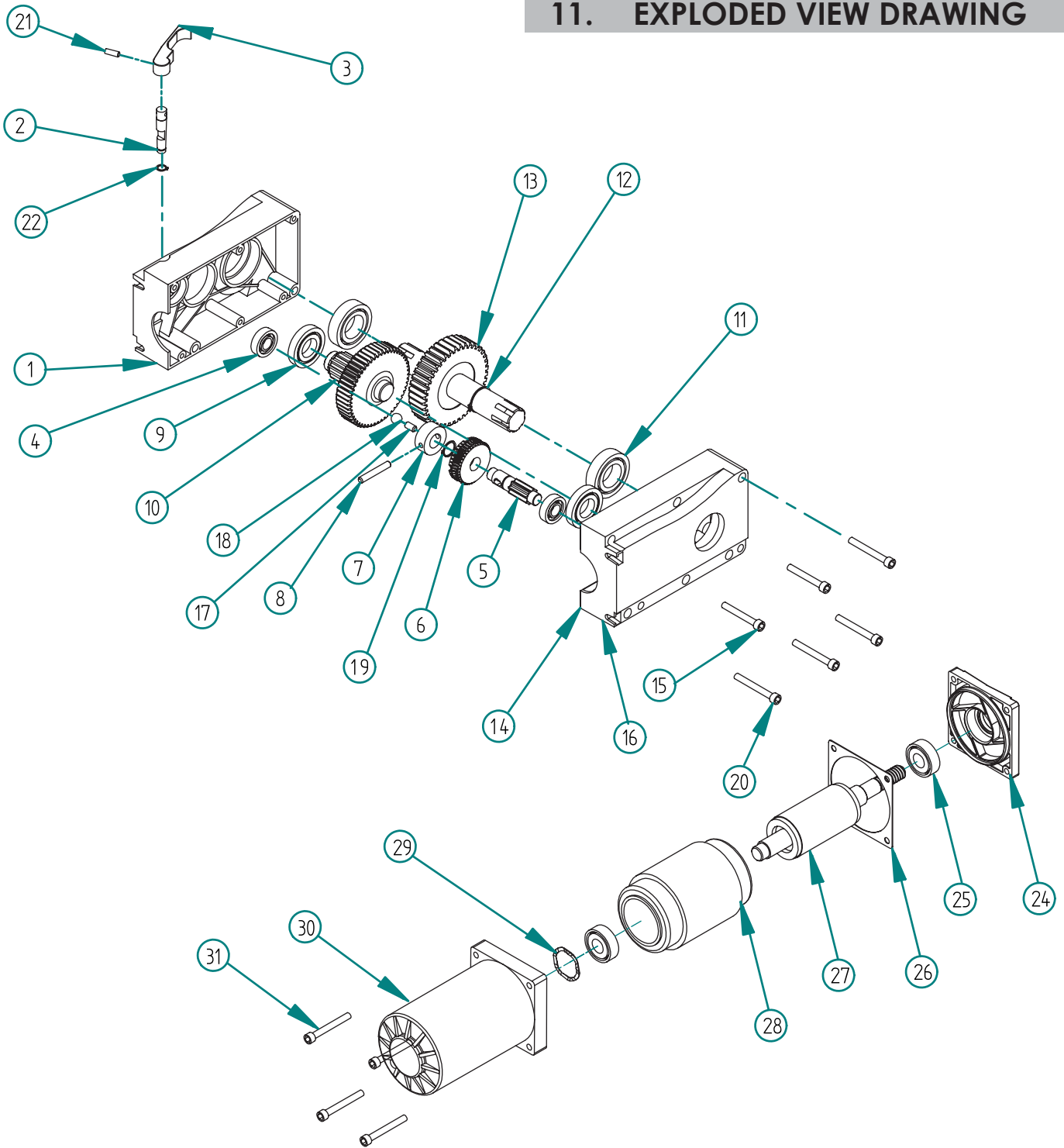

- 1. Guscio destro
- 2. Albero conico di sblocco
- 3. Levetta di sblocco
- 4. Cuscinetto 6001
- 5. Alberino con asola
- 6. Ruota dentata in bronzo
- 7. Distanziale in acciaio
- 8. Spina temprata 6x40
- 9. Cuscinetto 16004
- 10. Gruppo intermedio
- 11. Cuscinetto 6005
- 12. Anello elastico E25
- 13. Gruppo dentato finale
- 14. Guscio sinistro
- 15. Vite M6x45
- 16. Dado M6

- 17. Spina 6x12
- 18. Sfera temprata
- 19. Anello elastico E15
- 20. Vite M6x55
- 21. Grano M5x14
- 22. Anello elastico E8
- 23. Guarnizione motoriduttore
- 24. Flangia anteriore motore
- 25. Cuscinetto 6001-ZZ-EMQ
- 26. Guarnizione motore
- 27. Albero con rotore
- 28. Statore
- 29. Anello di compensazione
- 30. Tubo motore
- 31. Vite M6x40
- 32. 0.4 Kg Grasso AGIP NF2

- 1. Right shell
- 2. Conic shaft
- 3. Unlock system handle
- 4. Bearing 6001
- 5. Shaft with slot
- 6. Bronze gear
- 7. Spacer
- 8. Hardened steel pin 6x40
- 9. Bearing 16004
- 10. Middle gear group
- 11. Bearing 6005
- 12. Elastic ring E25
- 13. Torque shaft group
- 14. Left shell
- 15. Screw M6x45
- 16. Nut M6

- 17. Hardened steel pin 6x12
- 18. Hardened sphere
- 19. Elastic ring E15
- 20. Screw M6x55
- 21. Headless screw M5x14
- 22. Anello elastico E8
- 23. Guarnizione motoriduttore
- 24. Flangia anteriore motore
- 25. Cuscinetto 6001-ZZ-EMQ
- 26. Motor gasket
- 27. Motor shaft with rotor
- 28. Stator
- 29. Spring ring
- 30. Motor tube
- 31. Screw M6x40
- 32. 0.4 Kg Grease AGIP NF2