

# Q20A



### Control panel for single/double-leaf swing gates - 24V dc

- Adjustable obstacle detection feature
- Display for programming and trouble-shooting.
- Electronic adjustment of working and slowdown times for single motor.
- Dual programming modes: automatic or sequential step-by-step.
- Quick closing.
- Pedestrian opening.
- Delay time in opening and closing.
- Multi-occupation function.
- Pre-blinking.
- Second radio channel interface (**available as accessory**).
- Electric lock output integrated on board.
- Reversing stroke and lock pulse (for electric-lock installation only).
- Plug-in radio receiver 433,92MHz (99 users) suitable for both fixed and rolling-code Proteco's transmitters.
- Individual output for **MECHANICAL** N.C. and **RESISTIVE** 8K2 safety edges.
- Operational self diagnostic.

### TECHNICAL FEATURES

Item	PQ20A, PQ20A1D
Dimensions	137 x 84 x 37 mm
Box dimensions	220 x 290 x 90 mm
Pcb's weight	160 g
Main power	1700 g
Tension to control unit	230V ac ~ 50-60 Hz -10% +20%
Main power tolerance	20V ac
Transformer	230/20V – 130 VA
Main fuse	2 A
Battery fuse	10 A
Rated power input	250 W
Max. absorption rate	10 A
Absorption in stand-by	40 mA
Blinker	24V dc, max 20 W
Accessories	24V dc , max 5 W
Electric lock	12V, max 15 W
Working temperature	-20 +60 °C
IP rate (boxed)	IP55

## Index

1.	<b>WARNING AND INSTALLATION TIPS</b> .....	p. 02
2.	<b>COMPONENTS</b> .....	p. 03
3.	<b>WIRING TABLE</b> .....	p. 04
3.1	<b>MOTORS</b> .....	p. 06
3.2	<b>MAIN POWER</b> .....	p. 07
3.3	<b>START commands</b> .....	p. 07
	3.3.1 Timer .....	
	3.3.2 Key switch .....	
3.4	<b>PEDESTRIAN opening</b> .....	p. 07
3.5	<b>STOP emergency push button</b> .....	p. 08
3.6	<b>PHOTOCELLS</b> .....	p. 08
	3.6.1 Photocells in CLOSING .....	
	3.6.2 Photocells in OPENING .....	
3.7	<b>SAFETY EDGES</b> .....	p. 09
	3.7.1 Safety edge in CLOSING .....	
	3.7.2 Safety edge in OPENING .....	
3.8	<b>BLINKER</b> .....	p. 10
3.9	<b>ELECTRIC LOCK</b> .....	p. 10
3.10	<b>Second radio channel interface AUX / WARNING LIGHT / COURTESY LIGHT / MAGNETIC LOCK</b> .....	p. 10
	<b>MAIN CONTENTS</b> .....	p. 11
4.	<b>PROGRAMMING</b> .....	p. 13
4.1	<b>RADIO settings</b> .....	p. 13
	Recording a transmitter as START command .....	
	Recording a transmitter as PEDESTRIAN OPENING command .....	p. 14
	Recording a transmitter as SECOND RADIO CHANNEL .....	
	Deleting a single transmitter .....	p. 15
	Deleting all transmitters at once .....	
	Setting the 2nd RADIO CHANNEL interface .....	p. 16
4.2	<b>PROGRAMMING MODES</b> .....	p. 17
4.2.1	Setting the Programming Mode .....	
	AUTOMATIC MODE .....	
	SEQUENTIAL STEP BY STEP MODE .....	p. 18
4.2.2	Return to the DEFAULT settings .....	p. 18
4.3	<b>MOTOR TORQUE/OBSTACLE DETECTION</b> .....	p. 19
	OBSTACLE DETECTION - motor 1 .....	
	OBSTACLE DETECTION - motor 2 .....	
	SLOWDOWN SPEED - motor 1 .....	p. 20
	SLOWDOWN SPEED - motor 2 .....	
4.4	<b>FUNCTIONS</b> .....	p. 21
	AUTOMATIC CLOSING AFTER ENERGY POWER CUT .....	
	MULTI OCCUPATION .....	
	PRE-BLINKING .....	
	PHOTOCELL TEST .....	p. 22
	REVERSING STROKE .....	
	LOCK PULSE .....	p. 23
	QUICK CLOSING .....	
	SINGLE LEAF MODE .....	
	SEPARATE PUSH-BUTTONS .....	
	MOTORS' TEST .....	p. 24
	LEAF RELEASE IN CLOSING motor 1 .....	
	LEAF RELEASE IN OPENING - motor 1 and 2 .....	
	BLINKER TENSION .....	p. 25
4.5	<b>TIMES</b> .....	p. 26
	DELAY TIME in OPENING .....	
	DELAY TIME in CLOSING .....	
	AUTOMATIC CLOSING .....	p. 27
	PEDESTRIAN AUTOMATIC CLOSING .....	
	WORKING time - Motor 1 .....	
	WORKING time - Motor 2 .....	p. 28
	SLOWDOWN - Motor 1 .....	
	SLOWDOWN - Motor 2 .....	
	PEDESTRIAN OPENING .....	p. 29
	ELECTRIC LOCK .....	
4.6	<b>SAFETY DEVICES</b> .....	p. 30
	STOP emergency push button .....	
	PHOTOCELL in CLOSING .....	
	PHOTOCELL in OPENING .....	
	SAFETY EDGE in CLOSING .....	p. 31
	SAFETY EDGE in OPENING .....	
4.7	<b>MAINTENANCE/OPERATION recalls</b> .....	p. 32
	Display number of cycles performed (no possibility of reset) .....	
	Display maintenance countdown .....	
	Set maintenance service .....	p. 33
	Display installation date .....	
	Set installation date .....	
	Motors direct command .....	p. 34
5.	<b>TROUBLE SHOOTING</b> .....	p. 35
6.	<b>INSTALLATION BOX</b> .....	p. 36
7.	<b>DISPOSAL</b> .....	p. 36

# 1. WARNINGS AND INSTALLATION TIPS

**WARNING: This manual contains important information concerning personal safety. An incorrect installation or an improper use may lead to severe injuries.**

Read carefully and pay particular attention to the safety sections marked by the symbol .

Store this manual safely for future use.

 **Do not allow children or pets near your gate. Never let children operate or play with gate controls. Keep the remote controls away from children and unauthorised users.**

 **All wirings or operations on the control panel must be performed with the control panel disconnected from the power supply.**

 **Connect the control panel only to a power supply line equipped with safety grounding system.**

Wiring, settings and commissioning of this control board must be carried out by qualified and experienced personnel only. The installation has to comply to laws and regulations in force, with particular reference to EN 12453 provisions.

**This appliance is only to be used with the power supply unit provided with the appliance.**

**Means for disconnection must be incorporated in the fixed wiring in accordance with the wiring rules and wiring diagram (please see paragraph 3).**

**When operating a based-off switch, make sure that other persons are kept away.**

**Frequently examine the installation for signs of wear or damage to cables. Do not use if repair or adjustment is needed.**

This panel can control double leaf gate as well as single leaf gate.

**In case of single leaf gates, please pay particular attention to paragraphs marked by this symbol:**



## CE COMPLIANCE DECLARATION

Manufacturer: **PROTECO S.r.l.**  
Address: Via Neive, 77 - 12050 CASTAGNITO (CN) - ITALIA

### declares that

The product type: Q20A ELECTRONIC CONTROLLER for gate automation (1 or 2 motors), 24V  
Models: **PQ20A, PQ20A1D**  
Accessories: **MRX02**

Is built to be integrated into a machine or to be assembled with other machinery to create a machine under provisions of 2006/42/EC Machinery Directive.

It complies with the essential requirements of EEC Directives  
**2014/30/UE (EMC)**      **2014/35/UE (LVD)**  
**2014/53/UE (RED)**  
**RoHS2 2011/65/CE**

And with **EN 60335-1 - EN 60335-2-103**

The manufacturer declares that the start-up of the machinery is not permitted unless the machine, in which the product is incorporated or of which is becoming a component, has been identified and declared as conformed to 2006/42/EC Machinery Directive.

Note: These products have undergone test in a typical uniform configuration.

Castagnito, July 18th 2018

Marco Gallo  
CEO 



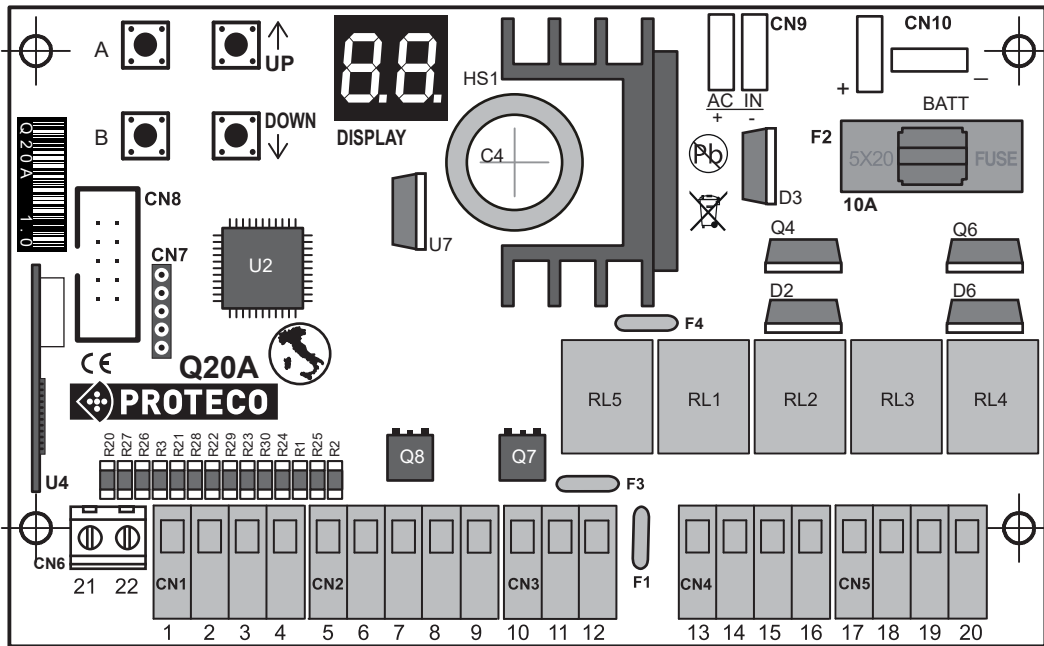

## 2. COMPONENTS



- DISPLAY** = LCD display  
**U4** = radio receiver  
**F1** = self-restoring fuse ACCESSORIES 24V - 0,5A  
**F2** = main fuse BATTERY 10A  
**F3** = self-restoring fuse BLINKER 24V - 1,6A  
**F4** = self-restoring fuse ELECTRIC LOCK 12V - 1,6A

- RL1** = relay motor **1 OPEN**  
**RL2** = relay motor **1 CLOSE**  
**RL3** = relay motor **2 OPEN**  
**RL4** = relay motor **2 CLOSE**  
**RL5** = relay ELECTRIC LOCK  
**CN1** = START COMMANDS  
**CN2** = PHOTOCELLS  
**CN3** = SAFETY EDGES  
**CN4** = ELECTRIC LOCK and BLINKER  
**CN5** = MOTORS **M1 - M2**  
**CN6** = EXTERNAL AERIAL  
**CN7** = SOFTWARE plug  
**CN8** = 2° RADIO CHANNEL interface plug  
**CN9** = SECONDARY - TRANSFORMER 20Vac plug  
**CN10** = BATTERY plug  
**Q7** = mosfet BLINKER  
**Q8** = mosfet PHOTOCELLS

### PROGRAMMING KEYS

A 	<b>ENTER / settings selection</b>
B 	<b>EXIT / SAVE</b>
	<b>UP</b> or <b>START</b> command
	<b>DOWN</b> or <b>PEDESTRIAN</b> command

# 3. WIRING TABLE

for **24Vdc** systems

English

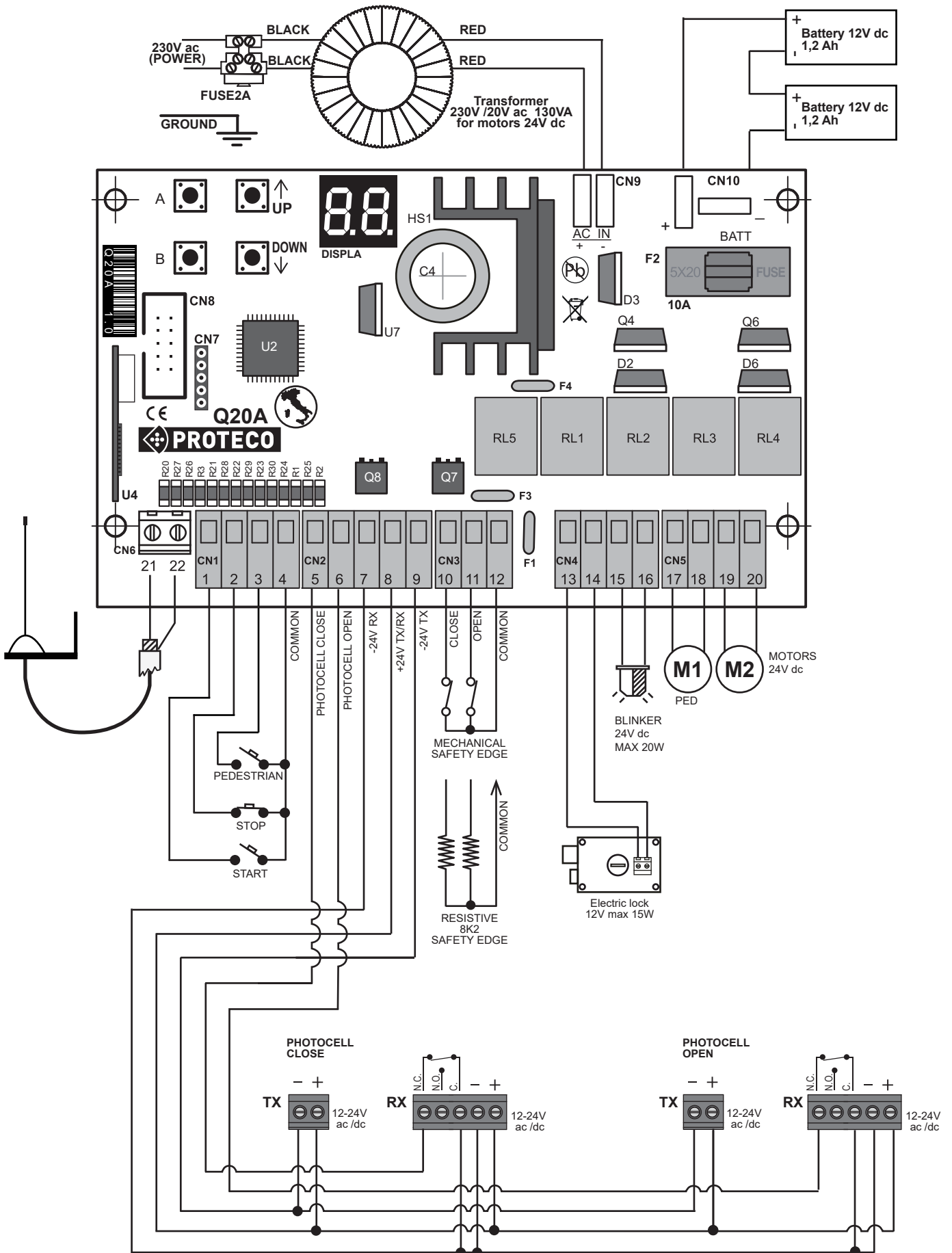

## Terminals (INPUTS / OUTPUTS)

### CN1 = START contacts

- 1 START (contact N.O.)
- 2 STOP push button (contact N.C.)
- 3 PEDESTRIAN START (contact N.O.)
- 4 COMMON

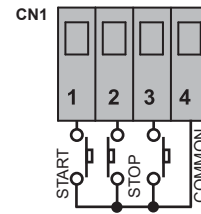

### CN2 = PHOTOCELLS

- 5 CLOSE (contact N.C.)
- 6 OPEN (contact N.C.)
- 7 RX PHOTOCCELL -24V
- 8 TX/RX +24V
- 9 TX PHOTOCCELL -24V

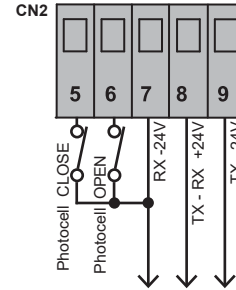

### CN3 = SAFETY EDGES

- 10 CLOSE
- 11 OPEN
- 12 COMMON

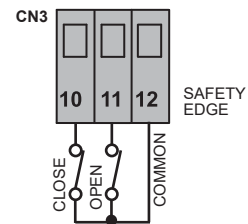

### CN4 = ELECTRIC LOCK and BLINKER

- 13 } Electric Lock 12V - 15W
- 14 }
- 15 } Blinker 24V dc 20W
- 16 }

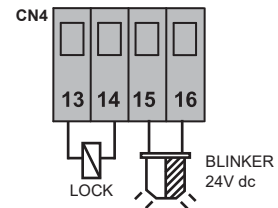

### CN5 = MOTORS M1 - M2

- 17 } MOTOR M1
- 18 }
- 19 } MOTOR M2
- 20 }

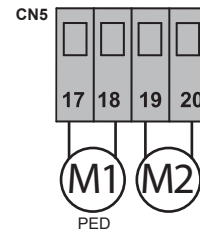

### CN6 = EXTERNAL AERIAL

- 21 Coaxial wire 1 (SIGNAL)
- 22 Coaxial wire 2 (EARTH)

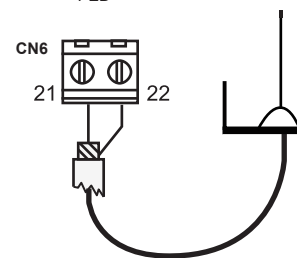

### CN8 = 2nd radio channel interface plug



### CN9 = secondary TRANSFORMER 20V ac

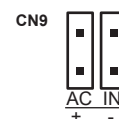

### CN10 = BATTERY

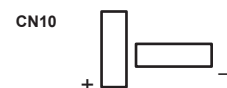







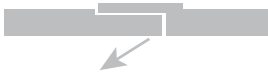
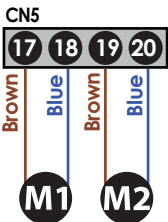

### 3.1 MOTORS wiring

- M1** motor 1 → first to open and **last to close**.
- M2** motor 2 → second to open and **first to close**.

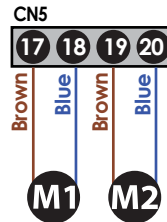
Wire **M1** to 17 - 18 terminal **CN5**.  
 Wire **M2** to 19 - 20 terminal **CN5**.

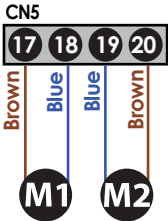
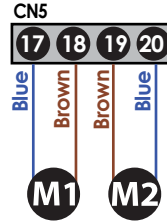
 In case of single leaf gate wire M1 to 17 - 18, terminal **CN5** and set **H9** to **01**.

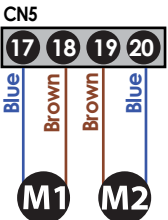
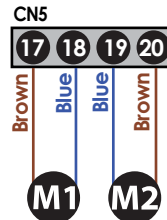
According to the type of motor you have make the connections as indicated in the below table:

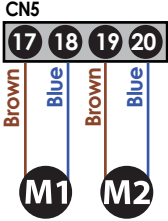
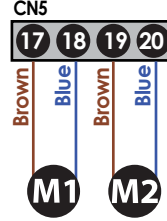
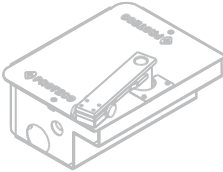
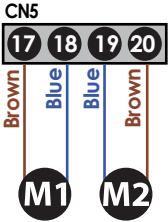
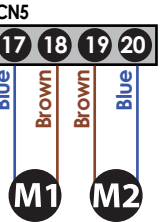
Motor type	Gate type	
	LH leaf that opens as 1st (M1)	RH leaf that opens as 1st (M1)
	 	 
		
		
		
		

## 3.2 MAIN POWER

Once all wirings are done, power the control unit. Connect the 230V to the **transformer (130VA, primary 230V – secondary 20V)** and the transformer's output to **CN9**.

### 3.2.1 BATTERY

In case of power cut it is possible to connect no. **2** back-up batteries 12V 1,2Ah to **CN10**.

### 3.2.2 DC TENSION

It is possible to power the control unit DC. Replace the transformer by any other kind of power bank and wire to **CN9**, as picture shows. Pay attention to polarity (+ / -). If polarity is inverted, the control unit automatically goes to low consumption mode.

If main power supply delivers more than 10A, it is necessary to wire in series a fuse of 10A.

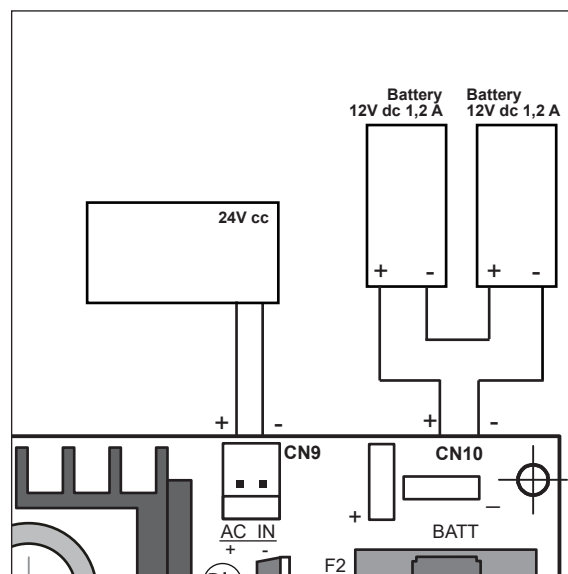

## 3.3 START PUSH BUTTON

It is possible to connect a START PUSH BUTTON (contact N.O.) to **1-4**, terminal **CN1**.

An additional START PUSH BUTTON shall be wired in **PARALLEL** (contact N.O.).

### 3.3.1 TIMER

It is possible to connect a TIMER (contact N.O.) to **1-4**, terminal **CN1**.

When the TIMER is fitted, the gate remains OPENED for the whole time set and then CLOSES automatically.

#### ATTENTION!:

If a **TIMER** is connected, it is necessary to set the **MULTI-OCCUPATION** function, **HI** on **01**.

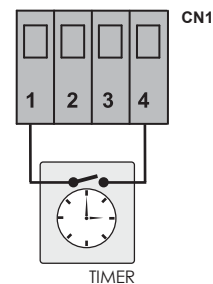
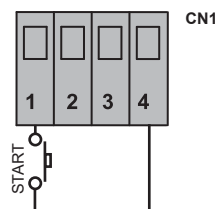

### 3.3.2 KEY SWITCH

It is possible to connect a KEY SWITCH (contact N.O.) to **1-4**, terminal **CN1**.

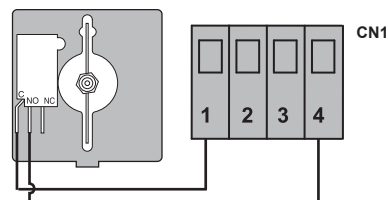

## 3.4 PEDESTRIAN OPENING

PEDESTRIAN START contacts (N.O.) must be wired to **3-4**, terminal **CN1**.

Additional PEDESTRIAN START contacts shall be wired in **PARALLEL** (contact N.O.).

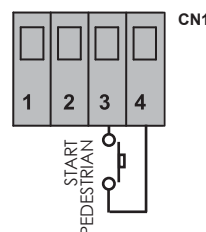



### 3.5 STOP PUSH BUTTON

Wire the STOP push button (contact N.C.) to **2-4**, terminal **CN1**.  
Additional STOP push buttons shall be wired in **series** (contact N.C.).

 **The emergency STOP push button is highly recommended for the safety of people and objects.**

**Attention:** The contact comes by default switched OFF.  
To activate the contact go to **P1** and set it to **01**

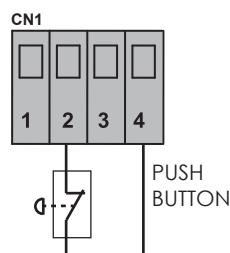
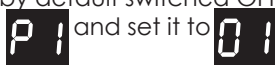

### 3.6 PHOTOCELLS

#### 3.6.1 Photocells in CLOSING

Wire the photocells to **7-8-9**, terminal **CN2**.  
Wire the N.C. contact of the photocells to **5-7**, terminal **CN2**.  
An additional set of photocells can be connected, wiring in **SERIES** the N.C. contacts.

- If the photocell beam is interrupted during CLOSING, the gate **STOPS** and **reverses** for **1,5 seconds**.
- If the photocell beam is interrupted during opening, the gate keeps on working normally.

 **For safety reasons a set of photocells must be installed to protect the gate CLOSING area**

NB: If no PHOTOCELL in CLOSING is connected, set **P2** to **00**.

#### 3.6.2 Photocells in OPENING

Wire the photocells to **7-8-9**, terminal **CN2**.  
Wire the N.C. contact of the photocells to **6-7**, terminal **CN2**.  
An additional set of photocells can be connected, wiring in **SERIES** the N.C. contacts.

- If the photocell beam is interrupted during opening, the gate **STOPS**.
- Once the beam is free from obstacles, the gate **RESTARTS** opening normally.
- When photocell's beam is broken during **CLOSING** the gate stops. When photocell's beam comes free, the gate **OPENS** again.

 **For safety reasons a set of photocells must be installed to protect the gate OPENING area.**

**Attention:** The contact comes by default switched OFF.  
To activate the photocell in OPENING go to **P3** and set it to **01**

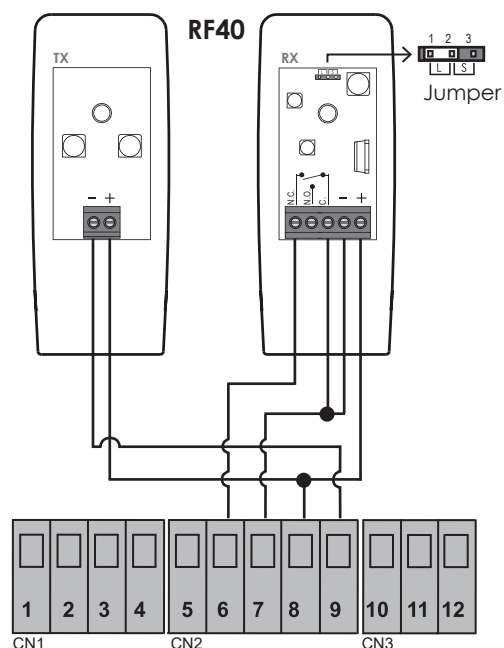
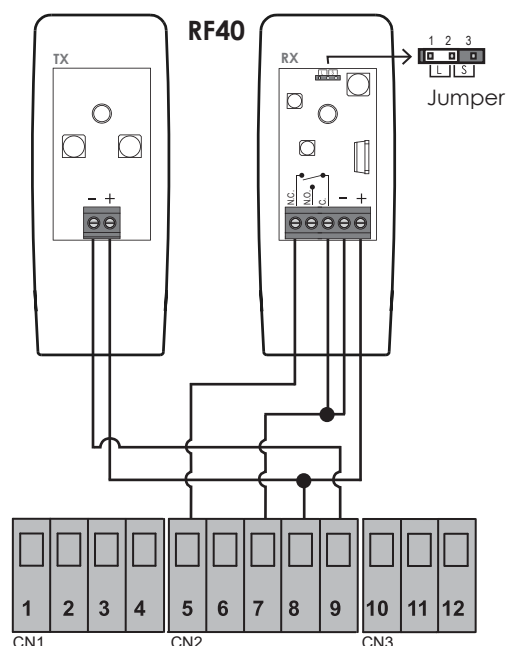

## 3.7 SAFETY EDGE

### 3.7.1 SAFETY EDGE IN CLOSING

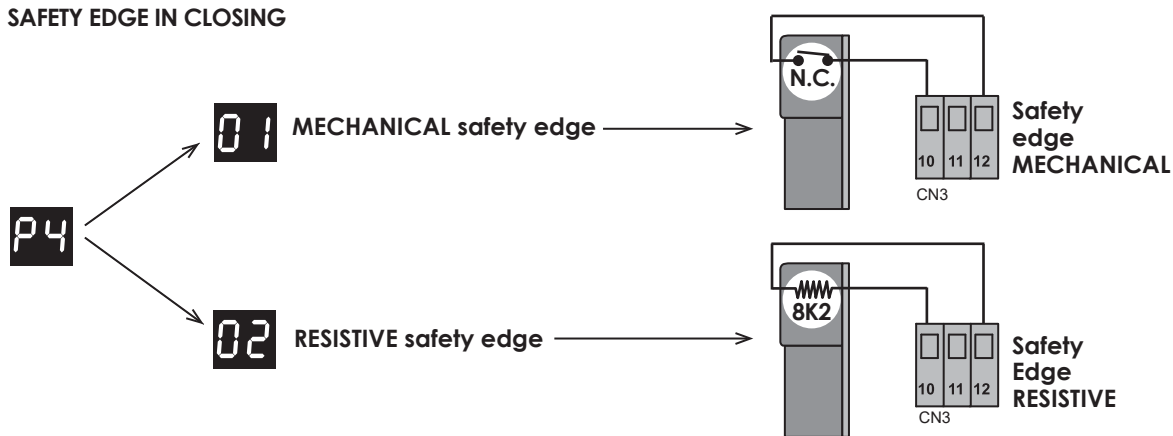

Wire the SAFETY EDGE to **10 – 12**, terminal **CN3**.

**Attention:** The contact comes by default switched OFF.

To activate the contact go to **P4** and set it to **01** or **02**

- The operation of the SAFETY EDGE in **CLOSING** stops the gate and reverses to opening position.
- The operation of the SAFETY EDGE in **OPENING** doesn't affect the normal duty cycle.



After the intervention of the safety edge in **CLOSING** the gate stays in **OPENING** position. Give a **START** command to restart the gate normal operation.

### 3.7.2 SAFETY EDGE IN OPENING

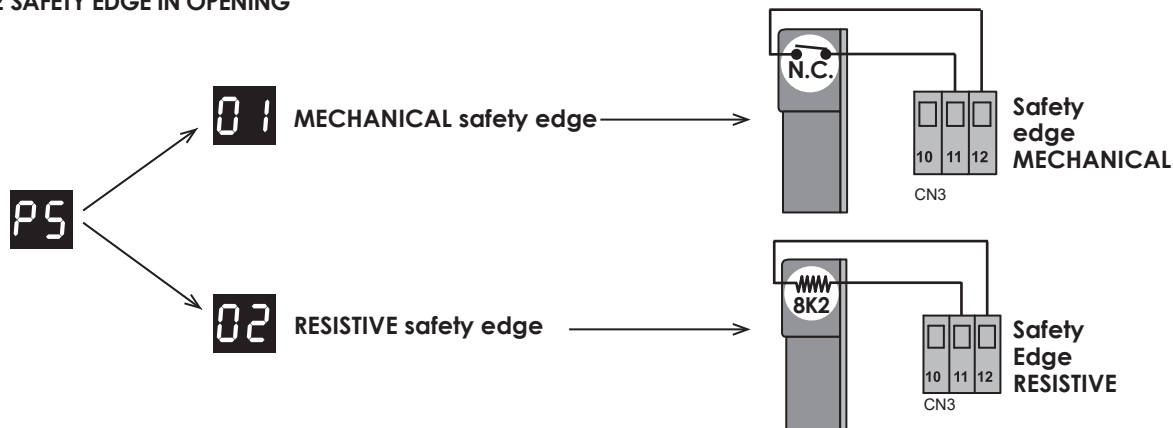

Wire the SAFETY EDGE to **11 – 12**, terminal **CN3**.

**Attention:** The contact comes by default switched OFF.

To activate the contact go to **P5** and set it to **01** or **02**

- The operation of the SAFETY EDGE in **OPENING** stops the gate and reverses to closing position for 10 cm. The gate remains still until giving another **OPENING** command.
- The operation of the SAFETY EDGE in **CLOSING** doesn't affect the normal duty cycle.



After the intervention of the safety edge in **OPENING** the gates stops and stays still. Give a **START** command to restart the normal operation.

### 3.8 BLINKER

Wire the blinker (max 20W) to **16- 17**, terminal **CN5**.

- **SLOW** flash → **OPENING**
- **QUICK** flash → **CLOSING**
- Light **ON and FIXED** → **COUNTDOWN**

NB:

The **HL** setting allows to choose the outgoing tension: **00** intermittent tension (Default), or **01** fixed tension.

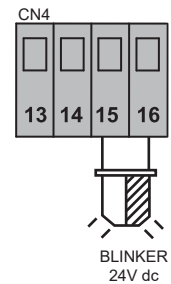

### 3.9 ELECTRIC LOCK

Wire the ELECTRIC LOCK to **13 - 14**, terminal **CN4**.

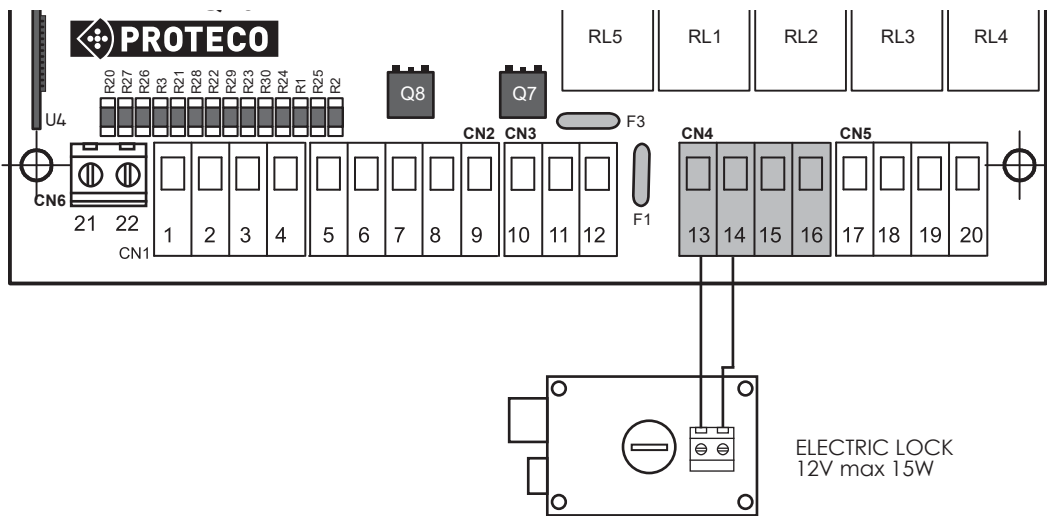

### 3.9 Second radio channel AUX / WARNING LIGHT / COURTESY LIGHT / MAGNETIC LOCK



Switch the **POWER OFF** before plugging the interface.

Plug the interface **MRX02** (sold as optional) into **CN8** according to the driving slot.

Go to **AA** and set **A6**.

**(OPTIONAL)**

MRX02

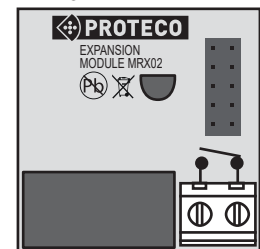

**RELAY  
MAX 1A - 24V**

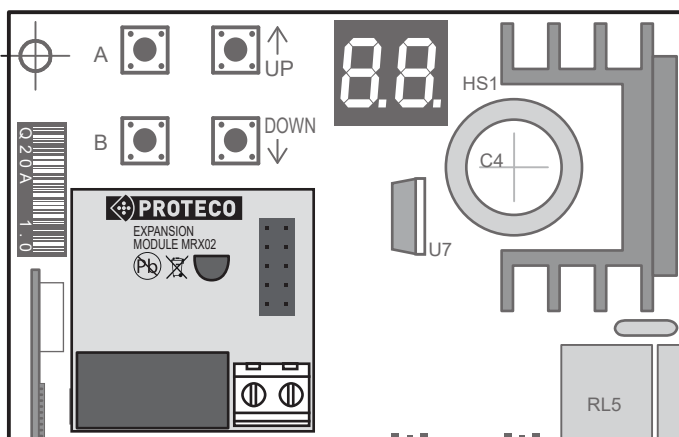

**SETTINGS TABLE**

DEFAULT settings are marked by this symbol



<b>AA RADIO settings</b>	
<b>A1</b>	RECORDING a transmitter as OPENING COMMAND 01.....99 (max) FL = full memory
<b>A2</b>	RECORDING a transmitter as PEDESTRIAN OPENING 01.....99 (max) FL = full memory
<b>A3</b>	RECORDING a transmitter as SECOND RADIO CHANNEL (optional) 01.....99 (max) FL = full memory
<b>A4</b>	DELETING a single transmitter 01.....99
<b>A5</b>	DELETING all transmitters at once
<b>A6</b>	SETTING the 2° radio channel interface 01.....06
<b>CC PROGRAMMING</b>	
<b>C1</b>	AUTOMATIC with <b>OBSTACLE DETECTION</b> feature
<b>C2</b>	<b>SEQUENTIAL</b> with <b>OBSTACLE DETECTION</b> feature (it may be switched OFF)
<b>C3</b>	Return to the DEFAULT SETTINGS
<b>FF MOTOR TORQUE / OBSTACLE DETECTION</b>	
<b>F3</b>	OBSTACLE DETECTION – <b>Motor 1</b>
<b>F4</b>	OBSTACLE DETECTION – <b>Motor 2</b>
<b>F5</b>	SLOWDOWN SPEED – <b>Motor 1</b> 01 (min)...05 (FL)..... 10 (max)
<b>F6</b>	SLOWDOWN SPEED – <b>Motor 2</b> 01 (min)...05 (FL)..... 10 (max)
<b>HH FUNCTIONS</b>	
<b>H0</b>	AUTOMATIC CLOSING AFTER ENERGY POWER CUT 00 = OFF      01 = ON (FL)
<b>H1</b>	MULTI-OCCUPATION 00 = OFF (FL)      01 = ON
<b>H2</b>	PRE-BLINKING 00 = OFF (FL)      01 = ON
<b>H4</b>	PHOTOCELL TEST 00 = OFF      01 = ON (FL)
<b>H5</b>	REVERSING STROKE (for electric lock only) 00 = OFF (FL)      01 = ON
<b>H6</b>	LOCK PULSE (for electric lock only) 00 = OFF (FL)      01 = ON
<b>H8</b>	QUICK CLOSING 00 = OFF (FL)      01 = ON
<b>H9</b>	SINGLE LEAF GATE 00 = OFF (FL)      01 = ON
<b>HA</b>	SEPARATE PUSH-BUTTONS Function 00 = OFF (FL)      01 = ON
<b>HC</b>	MOTOR TEST 00 = OFF      01 = ON (FL)
<b>HE</b>	LEAF RELEASE in CLOSING 00 = OFF (FL)      00...10 (max)
<b>HF</b>	LEAF RELEASE in OPENING 00 = OFF (FL)      00...10 (max)
<b>HL</b>	BLINKER VOLTAGE 00 = INTERMITTENT (FL) 01 = FIXED
<b>LL TIMES</b>	
<b>L1</b>	DELAY in OPENING 00 = OFF 01 (min)...02 (FL)..... 10 (max)
<b>L2</b>	DELAY in CLOSING 00 = OFF 01 (min)...05 (FL)..... 20 (max)
<b>L3</b>	AUTOMATIC CLOSING 00 = OFF 01 (min)...03 (FL)..... 99 (max)

<b>L4</b>	PEDESTRIAN AUTOMATIC CLOSING	00 = OFF 01 (min)...03 (max)
<b>L5</b>	WORKING TIME - <b>Motor 1</b> SEQUENTIAL mode only C2	00 = OFF 01 (min)...17 (max)
<b>L6</b>	WORKING TIME - <b>Motor 2</b> SEQUENTIAL mode only C2	00 = OFF 01 (min)...17 (max)
<b>L7</b>	SLOW DOWN - <b>Motor 1</b>	00 = OFF 01 (min)...07 (max)
<b>L8</b>	SLOW DOWN - <b>Motor 2</b>	00 = OFF 01 (min)...05 (max)
<b>L9</b>	PEDESTRIAN OPENING	00 = FULL OPENING 01 (min)...07 (max)
<b>LE</b>	ELECTRIC LOCK PULSE TIME	00 = OFF 01 (min)...02 (max)

**PP SAFETY DEVICES**

<b>P1</b>	STOP push button	00 = OFF 01 = ON
<b>P2</b>	PHOTOCELL in CLOSING	00 = OFF 01 = ON
<b>P3</b>	PHOTOCELL in OPENING	00 = OFF 01 = ON
<b>P4</b>	SAFETY EDGE in CLOSING	00 = OFF 01 = MECHANICAL ON
<b>P5</b>	SAFETY EDGE in OPENING	02 = RESISTIVE ON

**UU MAINTENANCE and SERVICE**

<b>U1</b>	Cycles performed (no possibility of RESET)	EX.: 12573 cycles Display shows the cycles performed in 3 sequences 01 25 73
<b>U2</b>	Set maintenance COUNTDOWN	00 = OFF EX: 123 cycles left to maintenance 00 01 23
<b>U3</b>	SET WORKING cycles	00 = OFF 01 = 1000 cycles 02 = 2000 cycles 99 = 99000 cycles(max)
<b>U4</b>	Display INSTALLATION DATE	00 = OFF day month year 10 08 18
<b>U5</b>	Set INSTALLATION DATE	00 = OFF day month year 10 08 18
<b>U6</b>	Motors DIRECT COMMAND	o1 = OPEN M1 c1 = CLOSE M1 o2 = OPEN M2 c2 = CLOSE M2

**SELF DIAGNOSTIC - Fault messages**

<b>--</b>	Control unit ready to program	<b>St</b>	START
<b>Fc</b>	PHOTOCELL in Closing	<b>Pd</b>	PEDESTRIAN START
<b>FA</b>	PHOTOCELL in Opening	<b>rd</b>	THE TRANSMITTER is compatible and can be saved
<b>bC</b>	SAFETY EDGE in Closing	<b>A</b>	OBSTACLE DETECTION M1 operating
<b>bA</b>	SAFETY EDGE in Opening	<b>A</b>	OBSTACLE DETECTION M2 operating
<b>SP</b>	STOP - open contact. Close the contact	<b>Sd</b>	SAVE settings
<b>00</b>	MOTORS running		→ QUICK ROTATION = normal operation SLOW ROTATION = slowdown

# MAIN TABLE

	Display	Main Settings
A		RADIO
		PROGRAMMING
A		MOTOR TORQUE/ OBSTACLE DETECTION
		FUNCTIONS
B		WORKING TIMES
		SAFETY DEVICES
		MAINTENANCE

## 4. PROGRAMMING

### 4.1 RADIO Settings

The control unit can manage both fixed and rolling code transmitters: once the first transmitter has been recorded, the control unit will only accept that kind of radio code. Therefore if the radio code entered is fixed code, the control unit will recognize just fixed code transmitters and viceversa. **NO RESET POSSIBLE.**

The radio capacity can store **fill 99 different users.**

Press A and use to go to setting

Press again A to select the RADIO MENU: the display shows

Use to choose the setting you wish within the RADIO MENU.

### Recording a TRANSMITTER as START command

Press one of the transmitter's key, the display shows:

= radio compatible  
or

= transmitter in storage

1	Scroll     to go to setting:	
2	<b>Press and hold the transmitter and at the same time press A </b> The display shows the radio code position.	
3	The display shows  when memory is full	
Repeat step 1 and 2 to record any additional transmitter.		
4	Press B  to return to previous setting, then press B  again as many times as the display shows: or wait 20 seconds, to go out of the programming automatically.	

## A2





### Recording a transmitter as PEDESTRIAN OPENING

Press one of the transmitter's key, the display shows:

**rd** = radio **compatible**

or

**01 02 ... 99** = Transmitter **in storage**

1	Scroll   to go to setting:	<b>A2</b>
2	<b>Press and hold the transmitter and at the same time press A</b>  The display shows the radio code position.	<b>01</b> <b>02 ...</b> <b>99 (max)</b>
3	The display shows <b>FL</b> when memory is full	<b>FL</b>
Repeat step 1 and 2 to record any additional transmitter as PEDESTRIAN OPENING.		
4	Press <b>B</b>  to return to previous setting, then press <b>B</b>  again as many times as the display shows: or wait 20 seconds, to go out of the programming automatically.	<b>Sd</b> (setting saved)

## A3

### Recording a transmitter as SECOND RADIO CHANNEL







**It is mandatory to plug the interface MRX02 into the according slot with power OFF**

Press one of the transmitter's key, the display shows:

**rd** = radio **compatibile**

or

**01 02 ... 99** = Transmitter **in storage**

1	Scroll   to go to setting:	<b>A3</b>
2	<b>Press and hold the transmitter and at the same time press A</b>  The display shows the radio code position.	<b>01</b> <b>02 ...</b> <b>99 (max)</b>
3	The display shows <b>FL</b> when memory is full	<b>FL</b>
Repeat step 1 and 2 to record any additional transmitter as SECOND RADIO CHANNEL.		
4	Press <b>B</b>  to return to previous setting, then press <b>B</b>  again as many times as the display shows: or wait 20 seconds, to go out of the programming automatically.	<b>Sd</b> (setting saved)

A4

## Deleting a single transmitter



To delete a single transmitter keep a full list of users..

1	Scroll   to go to setting:	A4
2	Press  to confirm	
3	Use   to select the radio code to delete	01...02 .....99
4	<b>Hold</b> for about <b>5 seconds until the display shows:</b>	5d
5	Release  . The control unit goes back to stand-by position	--
Repeat the procedure to delete other transmitters.		
6	Press  to return to previous setting, then press again  as many times as the display shows: or wait 20 seconds, to go out of the programming automatically.	5d (setting saved)









The TRANSMITTER POSITION DELETED will be subsequently available to save a NEW ONE.

A5

## Deleting all transmitters at once

1	Scroll   to go to setting:	A5
2	<b>Press and hold</b> for about <b>10 seconds</b> until the display shows: All codes are now deleted	5d
3	Release  . The control unit goes back to stand-by position	--
4	Press  to return to previous setting, then press again  as many times as the display shows: or wait 20 seconds, to go out of the programming automatically.	5d (setting saved)



1	Scroll   to go to setting:	<b>A6</b>
2	Press <b>A</b>  to confirm	
3	Use   to select the function:	<p>MONOSTABLE contact</p> <p>BISTABLE contact</p> <p>TIMER</p> <p>PILOT LIGHT</p> <p>COURTESY LIGHT</p> <p>MAGNETIC LOCK</p>
4	Press <b>B</b>  to return to previous setting, then press again <b>B</b>  as many times as the display shows: or wait 20 seconds, to go out of the programming automatically..	<p><b>SD</b> (setting saved)</p>

**01**

**MONOSTABLE contact**

The contact CLOSES only when the transmitter is pressed.

**02**

**BISTABLE contact**

The contact CLOSES or OPENS each time the transmitter is pressed.

**03**

**TIMER**

The contact CLOSES when pressing the transmitter and remains closed during 90 seconds.

**04**

**PILOT LIGHT when GATE IS OPENED**

The contact CLOSES when the gate starts OPENING and OPENS only when reaching the CLOSING position, no matters if the gate STOPS during operation.

**05**

**COURTESY LIGHT**

The contact CLOSES when the gate starts OPENING and OPENS 90 seconds after reaching the CLOSING position.

**06**



**MAGNETIC LOCK**

The contact is a permanent CLOSED contact (N.C.).  
The contact OPENS (N.O.) a second before the gate starts OPENING and CLOSES (N.C.) a second after the CLOSING cycle is completed.

## 4.2 PROGRAMMING

Press A  and croll   to go to setting 

Then press A  to go to PROGRAMMING: display shows 





Use   to select the according setting.

### 4.2.1 Setting the Programming mode.

#### AUTOMATIC programming with OBSTACLE DETECTION feature



##### ATTENTION:

**AUTOMATIC PROGRAMMING can only be performed with ground stops in Opening and Closing. The gate must be in CLOSING POSITION before starting program.**

1	Scroll   to go to setting:	
2	<b>Press and hold</b> A  for about <b>10 seconds</b> . When starting the programming the gate: <ul style="list-style-type: none"><li>• Closes for about 5 seconds</li><li>• Stops and starts opening till reaching the full opening position</li><li>• Stops briefly (about 3 sec.)</li><li>• Then starts closing</li><li>• Before reaching the closing position slows down</li></ul>	
3	Now the control unit has detected and saved automatically all working parameters and returns to stand-by position.	

##### IMPORTANT!

The  /  values affect the amperometric detection even during programming.

In case during programming leaves should stop due to the intervention of the obstacle detection, adjust parameters  and  , and proceed with a new programming.

Once the programming is completed, before starting the system, check that the obstacle detection function is working correctly. If not, re-adjust  and .







## C2 SEQUENTIAL STEP BY STEP programming with OBSTACLE DETECTION feature (it may be switched off)

MANUAL setting of the working times.





### ATTENTION:

The **SEQUENTIAL PROGRAMMING** can only be performed with ground stops in Opening and Closing.  
The gate must be in **CLOSING POSITION** before starting program.

SEQUENTIAL PROGRAMMING can be performed direct from  on the control unit or using a transmitter previously recorded.

1	Scroll   to go to setting:	C2
2	Press  To confirm. Display shows:	n1
3	Press the <b>transmitter</b> (or  ). • <b>Motor 1</b> starts opening.	
4	At <b>90%</b> of the opening cycle press again the <b>transmitter</b> (or  ). • <b>Motor 1</b> starts slowing down and reaches the opening position.	
5	Let <b>Motor 1</b> still for 4-5 seconds and then press again the transmitter (or  ). <b>Motor 1</b> working times are now set. The display shows:	n2
6	<b>Repeat step 3, 4, 5</b> to set <b>motor 2</b> <b>Motor 2</b> working times are now set. • the gate stops for about 3 seconds. • then starts closing • slow down and reaches the closing position	
7	Now the control unit has detected and saved automatically all working parameters and returns to stand-by position.	



### N.B.:

Once the programming is completed the value of  and  will automatically set to 10.  
Before starting the system, check that the obstacle detection function is working correctly.  
If not, re-adjust  and .

### 4.2.2 Return to the DEFAULT settings

The control unit is set with default working times and functions.  
If you wish to return to default settings follow the below procedure:

## C3 RESTORE FACTORY DATA (Default)

1	Scroll   to go to setting:	C3
2	<b>Press and hold</b>  for about 5 seconds.	
3	Factory data are restored and display shows:	5d (setting saved)

### 4.3 FF MOTOR TORQUE / OBSTACLE DETECTION

Use this function to set the sensibility of the OBSTACLE DETECTION.

Press A and scroll UP DOWN to go to setting **FF**

Press A to go to setting **F\_**

Use UP DOWN to select the according function.

### F3 OBSTACLE DETECTION ADJUSTMENT – MOTOR 1

1	Scroll  UP  DOWN to go to setting:	<b>F3</b>
2	Press A  to confirm. The display shows the OBSTACLE DETECTION value set.	
3	Use  UP  DOWN to change the sensitivity value of <b>motor 1</b> .  OFF MINIMUM SENSITIVITY MAXIMUM SENSITIVITY	00 (OFF) 01 (min) .... 10 (max)
4	Press B  to return to previous setting, then press B  again as many times as display shows or wait 20 seconds, to go out of the programming automatically.	5d (setting saved)







### F4 OBSTACLE DETECTION ADJUSTMENT - motor 2

1	Scroll  UP  DOWN to go to setting:	<b>F4</b>
2	Press A  to confirm. The display shows the OBSTACLE DETECTION value set.	
3	Use  UP  DOWN to change the sensitivity value of <b>motor 2</b> .  OFF MINIMUM SENSITIVITY MAXIMUM SENSITIVITY	00 (OFF) 01 (min) .... 10 (max)
4	Press B  to return to previous setting, then press B  again as many times as display shows or wait 20 seconds, to go out of the programming automatically.	5d (setting saved)







**N.B.:**

If OBSTACLE DETECTION works uncorrect (stops + reverses) change the sensitivity level **F3** - **F4** .

**F5****SLOWDOWN speed - motor 1**

1	Scroll   to go to setting:	<b>F5</b>
2	Press <b>A</b>  to confirm. The display shows SPEED value set.	<b>01</b> (min) <b>02</b>
3	Use   to change <b>SLOWDOWN speed</b> of <b>motor 1</b>	<b>05</b> (Default) ... <b>10</b> (max)
4	Press <b>B</b>  to return to previous setting, then press <b>B</b>  again as many times as display shows: or wait 20 seconds, to go out of the programming automatically.	<b>Sd</b> (setting saved)

**F6****SLOWDOWN speed - motor 2**

1	Scroll   to go to setting:	<b>F6</b>
2	Press <b>A</b>  to confirm. The display shows SPEED value set.	<b>01</b> (min) <b>02</b>
3	Use   to change <b>SLOWDOWN speed</b> of <b>motor 2</b> .	... <b>10</b> (max)
4	Press <b>B</b>  to return to previous setting, then press <b>B</b>  again as many times as display shows: or wait 20 seconds, to go out of the programming automatically.	<b>Sd</b> (setting saved)



**If SLOW DOWN speed has been changed, repeat the whole PROGRAMMING procedure.**

## 4.4 HH FUNCTIONS

Use this menu to TURN ON/OFF any special function.

**00** = OFF function DEACTIVATED







**01** = ON function ACTIVATED

Press **A**  and use   to go to setting **HH**

Press again **A**  to enter the menu: display shows **H\_**

Use   to select the according setting.







### H0 AUTOMATIC CLOSING AFTER POWER CUT

1	Scroll   to go to setting:	<b>H0</b>
2	Press <b>A</b>  to confirm.	
3	Use   to turn:	Function OFF Function ON
		<b>00</b> <b>01</b>
4	Press <b>B</b>  to return to previous setting, then press <b>B</b>  again as many times as display shows:	<b>5d</b> (setting saved)
	or wait 20 seconds, to go out of the programming automatically.	

### H1 MULTI-OCCUPATION







This function gives priority to **OPENING**:

**During the OPENING cycle, additional START commands will be ignored for all the duration of OPENING and COUNT DOWN.**

1	Scroll   to go to setting:	<b>H1</b>
2	Press <b>A</b>  to confirm.	
3	Use   to turn:	Function OFF Function ON
		<b>00</b> <b>01</b>
4	Press <b>B</b>  to return to previous setting, then press <b>B</b>  again as many times as display shows:	<b>5d</b> (setting saved)
	or wait 20 seconds, to go out of the programming automatically.	

### H2 PRE-BLINKING

This function activates a **pre-blinking during 4-5** seconds before any opening and closing cycle.

1	Scroll   to go to setting:	<b>H2</b>
2	Press <b>A</b>  to confirm.	
3	Use   to turn:	Function OFF Function ON
		<b>00</b> <b>01</b>
4	Press <b>B</b>  to return to previous setting, then press <b>B</b>  again as many times as display shows:	<b>5d</b> (setting saved)
	or wait 20 seconds, to go out of the programming automatically.	

**PHOTOCELL TEST**

The photocell test allows to check the good operation of the photocells at every opening and closing cycle.

1	Scroll   to go to setting:	H4
2	Press  to confirm.	
3	Use   to turn:	Function OFF Function ON
		00 01
4	Press  to return to previous setting, then press  again as many times as display shows:	5d (setting saved)
or wait 20 seconds, to go out of the programming automatically.		

**PHOTOCELL TEST OPERATION**

At every OPENING/CLOSING cycle, the control unit temporarily turns the power off from the photocell transmitter, to check the receiver relay performance.

If the check is successful and the relay contact exchange is correct (N.C. → N.O. → N.C.), the power is restored, for normal operation.

If a fault is detected the display shows (PHOTOCELL TEST FAILED).

**REVERSING STROKE**

**N.B. This function is activated just when an ELECTRIC LOCK is fitted.** When giving an OPENING command the gate goes to CLOSING position for **1 second** in order to help the lock release easily.

1	Scroll   to go to setting:	H5
2	Press  to confirm.	
3	Use   to turn:	Function OFF Function ON
		00 01
4	Press  to return to previous setting, then press  again as many times as display shows:	5d (setting saved)
or wait 20 seconds, to go out of the programming automatically.		

**LOCK PULSE**

**N.B. This function is activated just when an ELECTRIC LOCK is fitted.** When giving a CLOSING command the gate goes to CLOSING position and pushes for 1 second more in order to hook the lock correctly.

1	Scroll   to go to setting:	H6
2	Press  to confirm.	
3	Use   to turn:	Function OFF Function ON
		00 01
4	Press  to return to previous setting, then press  again as many times as display shows:	5d (setting saved)
or wait 20 seconds, to go out of the programming automatically.		

# H8

## QUICK CLOSING

By activating this function the gate closes **1 second** after passing through the photocell beam in closing (once the opening cycle has been completed).  
If the photocells are not involved, the gate will close according to the **AUTOMATIC CLOSING TIME** set.

1	Scroll   to go to setting:	H8
2	Press A  to confirm.	
3	Use   to turn:	Function OFF 00 Function ON 01
4	Press B  to return to previous setting, then press B  again as many times as display shows:	5d (setting saved)
or wait 20 seconds, to go out of the programming automatically.		

# H9

## SINGLE LEAF MODE



Enable this function in case of **single-leaf gate**.

1	Scroll   to go to setting:	H9
2	Press A  to confirm.	
3	Use   to turn:	Function OFF 00 Function ON 01
4	Press B  to return to previous setting, then press B  again as many times as display shows:	5d (setting saved)
or wait 20 seconds, to go out of the programming automatically.		

# HA

## SEPARATE PUSH-BUTTONS Function

This allows to use to different push-buttons/controls for opening and closing.

To use this function, you need to wire:







- opening push-button/control **START** terminals
- closing push-button/control **PEDESTRIAN START** terminals

1	Use   buttons to move inside the menu, till the display shows:	HA
2	Press button A  to confirm.	
3	Use   buttons to select:	SEPARATE PUSH-BUTTONS Function OFF 00 SEPARATE PUSH-BUTTONS Function ON 01
4	Press button B  to go back to the top level menus, then press button B  again till the display shows:	5d (setting saved)
or wait the timeout (20 seconds) to exit.		









**MOTORS' TEST**

This function allows to check the good operation of the motors in **opening and closing**.

1	Scroll   to go to setting:	HC
2	Press A  to confirm.	
3	Use   to turn:	Function OFF Function ON 00 01
4	Press B  to return to previous setting, then press B  again as many times as display shows: or wait 20 seconds, to go out of the programming automatically.	5d (setting saved)







**LEAF RELEASE in CLOSING - motor 1**

This function allows **motor 1** to release thrust force on the gate when full **closing** has been completed.

1	Scroll   to go to setting:	HE
2	Press A  to confirm.	
3	Use   to set thrust force value:	00(OFF) 01 (min) .... 10 (max)
4	Press B  to return to previous setting, then press B  again as many times as display shows: or wait 20 seconds, to go out of the programming automatically.	5d (setting saved)







**LEAF RELEASE in OPENING - motor 1 and 2**

This function allows **motor 1 and 2** to release thrust force on the gate when full **opening** has been completed.

1	Scroll   to go to setting:	HF
2	Press A  to confirm.	
3	Use   to set thrust force value:	00(OFF) 01 (min) .... 10 (max)
4	Press B  to return to previous setting, then press B  again as many times as display shows: or wait 20 seconds, to go out of the programming automatically.	5d (setting saved)



This function allows to select the blinker output tension.



1	Scroll   to go to setting:	HL
2	Press <b>A</b>  to confirm.	
3	Use   to select the output tension	INTERMITTENT (Default) FIXED
4	Press <b>B</b>  to return to previous setting, then press <b>B</b>  again as many times as display shows:	00 01
	or wait 20 seconds, to go out of the programming automatically.	5d (setting saved)

## 4.5 **LL** TIMES settings

This menu enables to set any **WORKING TIME** as well as **COUNTDOWN** for **AUTOMATIC CLOSING**.







Press **A**  and use   to go to main menu **LL**

Press again **A**  to go to **L\_**

Use   to select the according setting.







### **L1** DELAY TIME in OPENING

This function allows to set **the delay time in opening**.

1	Scroll   to go to setting:	<b>L1</b>
2	Press <b>A</b>  to confirm.	
3	Use   to set the delay time in OPENING:  Setting <b>00</b> the <b>DELAY TIME in OPENING is turned OFF</b>	<b>00</b> (OFF) <b>01</b> .... <b>10</b> (max)
4	Press <b>B</b>  to return to previous setting, then press <b>B</b>  again as many times as display shows:  or wait 20 seconds, to go out of the programming automatically.	<b>5d</b> (setting saved)

### **L2** DELAY TIME in CLOSING

This function allows to set **the delay time in closing**.

1	Scroll   to go to setting:	<b>L2</b>
2	Press <b>A</b>  to confirm.	
3	Use   to set the delay time in CLOSING:  Setting <b>00</b> the <b>DELAY TIME in CLOSING is turned OFF</b> .	<b>00</b> (OFF) <b>01</b> .... <b>20</b> (max)
4	Press <b>B</b>  to return to previous setting, then press <b>B</b>  again as many times as display shows:  or wait 20 seconds, to go out of the programming automatically.	<b>5d</b> (setting saved)

L3

**AUTOMATIC CLOSING**

This function enables to set the countdown for the **AUTOMATIC CLOSING**.

1	Scroll   to go to setting:	L3
2	Press <b>A</b> to confirm.	
3	Use   to set the countdown:  Setting <b>00</b> the <b>AUTOMATIC CLOSING</b> is <b>TURNED OFF</b>	00 (OFF) 01 ... 99 (max)
4	Press <b>B</b> to return to previous setting, then press <b>B</b> again as many times as display shows:  or wait 20 seconds, to go out of the programming automatically.	5d (setting saved)

L4

**PEDESTRIAN AUTOMATIC CLOSING**

This function enables to set the countdown for the **PEDESTRIAN AUTOMATIC CLOSING**.

1	Scroll   to go to setting:	L4
2	Press <b>A</b> to confirm.	
3	Use   to set the pedestrian countdown:  Setting <b>00</b> the <b>PEDESTRIAN AUTOMATIC CLOSING</b> is <b>TURNED OFF</b>	00 (OFF) 01 ... 99 (max)
4	Press <b>B</b> to return to previous setting, then press <b>B</b> again as many times as display shows:  or wait 20 seconds, to go out of the programming automatically.	5d (setting saved)

L5

**WORKING time - Motor 1**

This function enables to set the working time in **opening/closing** of **motor 1**.



This function applies **ONLY** with **SEQUENTIAL PROGRAMMING** **[2]**

The **AUTOMATIC PROGRAMMING** **[1]** on the contrary sets automatically the working time and cannot be changed.

1	Scroll   to go to setting:	L5
2	Press <b>A</b> to confirm.	
3	Use   to decrease/increase <b>motor 1 working time</b> .	01 ... 99 (max)
4	Press <b>B</b> to return to previous setting, then press <b>B</b> again as many times as display shows:  or wait 20 seconds, to go out of the programming automatically.	5d (setting saved)

## WORKING time - Motor 2

This function enables to set the working time in **opening/closing** of **motor 2**.



This function applies **ONLY** when **SEQUENTIAL PROGRAMMING** is performed **[2]**.

The **AUTOMATIC PROGRAMMING [1]** on the contrary sets automatically the working time and cannot be changed.

1	Scroll   to go to setting:	L6
2	Press <b>A</b> to confirm.	
3	Use   to decrease/increase <b>motor 2 working time</b> .	01 ... 99 (max)
4	Press <b>B</b> to return to previous setting, then press <b>B</b> again as many times as display shows: or wait 20 seconds, to go out of the programming automatically.	5d (setting saved)

## SLOWDOWN – Motor 1

This function enables to set slowdown in **opening/closing** of **motor 1**.

1	Scroll   to go to setting:	L7
2	Press <b>A</b> to confirm.	
3	Use   to decrease/increase <b>motor 1 slowdown time</b> :  Setting <b>00</b> <b>motor 1 SLOWDOWN turns OFF</b>	00(OFF) 01 (min) ... 10 (max)
4	Press <b>B</b> to return to previous setting, then press <b>B</b> again as many times as display shows: or wait 20 seconds, to go out of the programming automatically.	5d (setting saved)









## SLOWDOWN - Motor 2

This function enables to set slowdown in **opening/closing** of **motor 2**.

1	Scroll   to go to setting:	
2	Press <b>A</b> to confirm.	L8
3	Use   to decrease/increase <b>motor 2 slowdown time</b> .  Setting <b>00</b> <b>motor 2 SLOWDOWN turns OFF</b>	00(OFF) 01 (min) ... 10 (max)
4	Press <b>B</b> to return to previous setting, then press <b>B</b> again as many times as display shows: or wait 20 seconds, to go out of the programming automatically.	5d (setting saved)







## PEDESTRIAN OPENING

This function enables to set the **pedestrian opening** of **motor 1**.

1	Scroll   to go to setting:	L9
2	Press <b>A</b>  to confirm.	
3	Use   to set the <b>pedestrian opening time</b> :   Setting  the pedestrian leaf will fully open.	00 (full opening)  01 (min) ... 12 (max)
4	Press <b>B</b>  to return to previous setting, then press <b>B</b>  again as many times as display shows:  or wait 20 seconds, to go out of the programming automatically.	5d (setting saved)

## ELECTRIC LOCK

This function enables to set the ELECTRIC LOCK pulse time.



1	Scroll   to go to setting:	LE
2	Press <b>A</b>  to confirm.	
3	Use   to set the pulse time:	01 (min) ... 05 (max)
4	Press <b>B</b>  to return to previous setting, then press <b>B</b>  again as many times as display shows:  or wait 20 seconds, to go out of the programming automatically.	5d (setting saved)

## 4.6 PP SAFETY DEVICES







This menu helps setting and handling the **safety devices**.

Press **A**  and scroll   to go to setting **PP**.







Press again **A**  to confirm, the display shows **P\_**.

Use   to select the according setting.







### P1 STOP emergency push button

1	Scroll   to go to setting:	P1
2	Press <b>A</b>  to confirm.	
3	Use   to turn the contact: <b>OFF – stop button deactivated</b> <b>ON – stop button activated</b>	00 01
4	Press <b>B</b>  to return to previous setting, then press <b>B</b>  again as many times as display shows: or wait 20 seconds, to go out of the programming automatically.	Sd (setting saved)







### P2 PHOTOCELL in CLOSING

1	Scroll   to go to setting:	P2
2	Press <b>A</b>  to confirm.	
3	Use   to turn the contact: <b>OFF – photocell in closing deactivated</b> <b>ON – photocell in closing activated</b>	00 01
4	Press <b>B</b>  to return to previous setting, then press <b>B</b>  again as many times as display shows: or wait 20 seconds, to go out of the programming automatically.	Sd (setting saved)







### P3 PHOTOCELL in OPENING

1	Scroll   to go to setting:	P3
2	Press <b>A</b>  to confirm.	
3	Use   to turn the contact: <b>OFF – photocell in opening deactivated</b> <b>ON – photocell in opening activated</b>	00 01
4	Press <b>B</b>  to return to previous setting, then press <b>B</b>  again as many times as display shows: or wait 20 seconds, to go out of the programming automatically.	Sd (setting saved)

**P4****SAFETY EDGE in CLOSING**

1	Scroll   to go to setting:	<b>P4</b>
2	Press <b>A</b>  to confirm.	
3	Use   to turn the contact: <b>OFF</b> - safety edge in <b>closing deactivated</b> <b>ON</b> - MECHANICAL safety edge in <b>closing activated</b> (N.C.) <b>ON</b> - RESISTIVE safety edge in <b>closing activated</b> (8K2)	<b>00</b> <b>01</b> <b>02</b>
4	Press <b>B</b>  to return to previous setting, then press <b>B</b>  again as many times as display shows: or wait 20 seconds, to go out of the programming automatically.	<b>5d</b> (setting saved)

**P5****SAFETY EDGE in OPENING**

1	Scroll   to go to setting:	<b>P5</b>
2	Press <b>A</b>  to confirm.	
3	Use   to turn the contact: <b>OFF</b> - safety edge in <b>opening deactivated</b> <b>ON</b> - MECHANICAL safety edge in <b>opening activated</b> (N.C.) <b>ON</b> - RESISTIVE safety edge in <b>opening activated</b> (8K2)	<b>00</b> <b>01</b> <b>02</b>
4	Press <b>B</b>  to return to previous setting, then press <b>B</b>  again as many times as display shows: or wait 20 seconds, to go out of the programming automatically.	<b>5d</b> (setting saved)



## 4.7 **UU** MAINTENANCE and SERVICE SETTING

This menu displays all data and maintenance status of your electric gate.









Press **A**  and scroll   to go to setting **UU**.

Press again **A**  to confirm, the display shows **U\_**.

Use   to select the according setting.











### **U1** Cycles performed (no possibility of reset)

This feature shows **how many OPERATIONS** your gate performed.

1	Scroll   to go to setting:	<b>U1</b>
2	Press <b>A</b>  Display shows the number of complete cycles performed. <b>ex:</b> a control unit that performed <b>12573 cycles</b> , the display will show 3 views in sequence     First view                                      Second view                                      Third view	
3	Press <b>B</b>  to return to previous setting, then press <b>B</b>  again as many times as display shows:	<b>5d</b> (setting saved)
	or wait 20 seconds, to go out of the programming automatically.	







### **U2** Maintenance countdown

This features shows **the number of cycles left to MAINTENANCE**

1	Scroll   to go to setting:	<b>U2</b>
2	Press <b>A</b>   • If display shows 3 times  maintenance countdown has not been set (default) • if display shows a view in 3 sequences like:     First view                                      Second view                                      Third view  <b>It means 123 cycles left to maintenance service.</b>	<b>00</b>
	 When countdown comes to the end the blinker flashes 5 times every 5 minutes, after every full operation, while the display shows <b>U3</b> proceed now to maintenance.	
3	Press <b>B</b>  to return to previous setting, then press <b>B</b>  again as many times as display shows:	<b>5d</b> (setting saved)
	or wait 20 seconds, to go out of the programming automatically.	





**U3****Setting maintenance service**

This function enables to set the number of **CYCLES** to next maintenance service.

1	Scroll   to go to setting:	<b>U3</b>
2	Press <b>A</b> 	
3	Use   to set the desired number of cycles till next maintenance service.  The number of cycles entered in <b>U3</b> will be automatically transferred as well to setting <b>U2</b> (cycles left to maintenance)	(1000 cycles) <b>01</b> (2000 cycles) <b>02</b> (55000 cycles) <b>55</b> (99000 cycles) <b>99</b>
4	Press <b>B</b>  to return to previous setting, then press <b>B</b>  again as many times as display shows:  or wait 20 seconds, to go out of the programming automatically.	<b>Sd</b> (setting saved)

**U4****Displaying installation date**

This function shows the **INSTALLATION DATE**.

1	Scroll   to go to setting:	<b>U4</b>
2	Press <b>A</b>  to confirm:  • If display shows 3 times <b>00</b> installation date has not been set. • if display shows a view in 3 sequences, installation date has been set:  <b>10</b> day <b>08</b> month <b>18</b> year	<b>00</b>
3	Press <b>B</b>  to return to previous setting, then press <b>B</b>  again as many times as display shows:  or wait 20 seconds, to go out of the programming automatically.	<b>Sd</b> (setting saved)

### Set installation date

This function enables to set **the date of first INSTALLATION.**

1	Scroll   to go to setting:	U5
2	Press  to confirm: If display shows 3 times  installation date has not been set	00
3	Use   to set the <b>day</b> and press  to confirm. Use   to set the <b>month</b> and press  to confirm. Use   to set the <b>year</b> and press  to confirm ex:  day  month  year	
4	Press  to return to previous setting, then press  again as many times as display shows: or wait 20 seconds, to go out of the programming automatically.	Sd (setting saved)

### Motors direct command

This function enables to check the **correct motors' operation** or to reach electrically **limit switches in Opening/Closing** without unlocking the motors

1	Scroll   to go to setting:	U6
2	Press  to select	n1/n2
3	Use   to.  → <b>OPEN motor 1</b> while holding the key <b>CLOSE motor 1</b> while holding the key  → <b>OPEN motor 2</b> while holding the key <b>CLOSE motor 2</b> while holding the key  Holding the keys pressed, the display shows the force used at that moment.	
4	Press  to return to previous setting, then press  again as many times as display shows: or wait 20 seconds, to go out of the programming automatically.	Sd (setting saved)

## 5. TROUBLE SHOOTING

The control unit is designed to display the most common faults.  
Here below the fault table and possible solutions.

Fault	Probable cause	Solution
<b>88</b> DISPLAY TURNED OFF	<ul style="list-style-type: none"> <li>No tension.</li> <li>Fuses damaged.</li> <li>Transformer damaged.</li> </ul>	<p>Check the power supply.</p> <p>Find the cause and replace the fuse. Check wiring as well as in/out transformer's tension.</p>
<b>FC</b> PHOTOCELL CLOSING	<ul style="list-style-type: none"> <li>Non-calibrated photocell.</li> <li>Obstacle in between.</li> </ul>	<p>Check the calibration between receiver and transmitter. Remove the obstacle and clean the lenses from dirt.</p>
	<ul style="list-style-type: none"> <li>Incorrect wiring.</li> <li>Non-powered photocell.</li> <li>Disconnected photocell, disconnected output.</li> </ul>	<p>Check the wiring.</p> <p>Check the tension on the transmitter and receiver. Turn <b>P2 OFF</b>. (see paragraph 3.6.1)</p>
	<ul style="list-style-type: none"> <li>Non-calibrated photocell</li> <li>Obstacle in between.</li> </ul>	<p>Check the calibration between receiver and transmitter. Remove the obstacle and clean the lenses from dirt.</p>
<b>FA</b> PHOTOCELL OPENING	<ul style="list-style-type: none"> <li>Non-calibrated photocell</li> <li>Obstacle in between.</li> </ul>	<p>Check the calibration between receiver and transmitter. Remove the obstacle and clean the lenses from dirt.</p>
	<ul style="list-style-type: none"> <li>Incorrect wiring.</li> <li>Non-powered photocell.</li> <li>Disconnected photocell, disconnected output.</li> </ul>	<p>Check the wiring.</p> <p>Check the tension on the transmitter and receiver. Turn <b>P3 OFF</b>. (see paragraph 3.6.2)</p>
	<ul style="list-style-type: none"> <li>Incorrect wiring.</li> <li>Non-compatible photocells.</li> </ul>	<p>Check the wiring.</p> <p>Use Proteco's photocells.</p>
<b>FE</b> PHOTOCELL TEST	<ul style="list-style-type: none"> <li>Incorrect wiring.</li> <li>Non-compatible photocells.</li> </ul>	<p>Check the wiring.</p> <p>Use Proteco's photocells.</p>
<b>bc</b> SAFETY EDGE CLOSING	<ul style="list-style-type: none"> <li>Safety edge disconnected.</li> <li>Incorrect wiring.</li> <li>Input disabled.</li> </ul>	<p>Check the wiring.</p> <p>Check the wiring.</p> <p>Turn <b>P4 OFF</b>.</p>
	<ul style="list-style-type: none"> <li>Incorrect mode selection (MECHANICAL - RESISTIVE)</li> <li>Incorrect micro adjustment.</li> </ul>	<p>Check the safety edge type and set <b>P4</b> accordingly.</p> <p>Adjust the inox wire tension.</p>
	<ul style="list-style-type: none"> <li>Disconnected safety edge.</li> <li>Incorrect wiring.</li> <li>Input disabled.</li> </ul>	<p>Check the wiring.</p> <p>Check the wiring.</p> <p>Turn <b>P5 OFF</b>.</p>
<b>ba</b> SAFETY EDGE OPENING	<ul style="list-style-type: none"> <li>Disconnected safety edge.</li> <li>Incorrect wiring.</li> <li>Input disabled.</li> </ul>	<p>Check the wiring.</p> <p>Check the wiring.</p> <p>Turn <b>P5 OFF</b>.</p>
	<ul style="list-style-type: none"> <li>Incorrect mode selection (MECHANICAL - RESISTIVE)</li> <li>Incorrect micro adjustment.</li> </ul>	<p>Check the safety edge type and set <b>P5</b> accordingly.</p> <p>Adjust the inox wire tension.</p>
	<ul style="list-style-type: none"> <li>Disconnected button.</li> </ul>	<p>Check the stop button wiring or turn <b>P1 OFF</b>. (see paragraph 3.5)</p>
<b>SP</b> STOP PUSH BUTTON	<ul style="list-style-type: none"> <li>Disconnected button.</li> </ul>	<p>Check the stop button wiring or turn <b>P1 OFF</b>. (see paragraph 3.5)</p>
<b>St</b> START COMMAND	<ul style="list-style-type: none"> <li>Incorrect wiring.</li> </ul>	<p>Check the wiring. (paragraph 3.5)</p>
	<ul style="list-style-type: none"> <li>Permanent start command.</li> </ul>	<p>Check the good operation of all devices connected to START (contact N.O.) (see paragraph 3.3).</p>
<b>Pd</b> PEDESTRIAN COMMAND	<ul style="list-style-type: none"> <li>Pedestrian start command.</li> </ul>	<p>Check the good operation of all devices connected to PEDESTRIAN START (contact N.O.) (see paragraph 3.4).</p>
<b>NE</b> MOTORS' TEST	<ul style="list-style-type: none"> <li>Disconnected motors.</li> </ul>	<p>Wire the motors according to the wiring table.</p>
	<ul style="list-style-type: none"> <li>Incorrect wiring.</li> </ul>	<p>Check motors' wiring (paragraph 3.1).</p>
	<ul style="list-style-type: none"> <li>Capacitor damaged.</li> </ul>	<p>Use a tester to check the stator's tension.</p>
<b>rd</b> PERMANENT RADIO SIGNAL	<ul style="list-style-type: none"> <li>Unknown TRANSMITTER not in memory.</li> </ul>	<p>Check the transmitter's keys.</p> <p>If a key sticks, the transmitter led remains on and fixed. Remove the transmitter's battery and make sure the fault disappears from display.</p>
	<ul style="list-style-type: none"> <li>PERMANENT START COMMAND FROM AN EXISTING TRANSMITTER.</li> </ul>	<p>Check the transmitter's keys.</p> <p>If a key sticks, the transmitter led remains on and fixed. Remove the transmitter's battery and make sure the fault disappears from display.</p>
<b>01</b> <b>02</b> <b>50</b> <b>99</b>		
<b>U3</b> COUNTDOWN COMPLETED blinker flashes every 5 sec.	<ul style="list-style-type: none"> <li>Proceed to maintenance service.</li> </ul>	<p>Reset the maintenance service</p>

## 6. BOX Installation

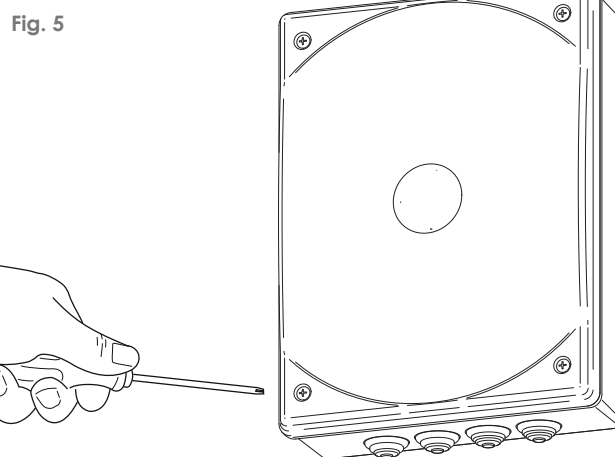
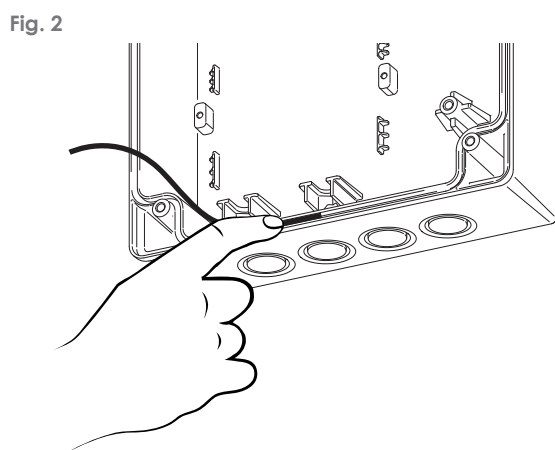
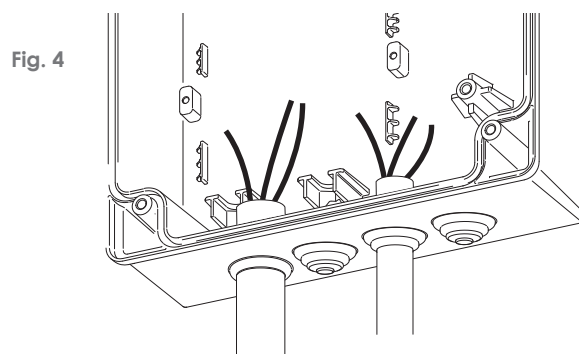
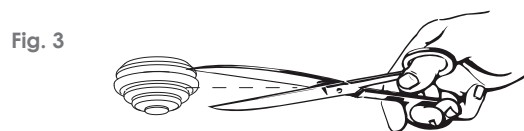
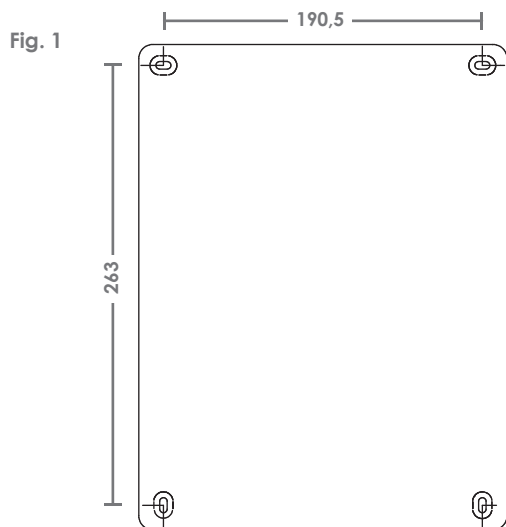

- 1) Choose the place for the box and mark the fixing points on the wall. Pay attention to respect the distances between the holes (fig. 1).
- 2) Make the drillings and fix the box with the pre-drilled holes downwards.
- 3) Slip the washer round the edge of the box, starting from centre down (fig. 2). Do not extend the washer, just push it into its housing and cut any excess.
- 4) Cut the rubber grommets the same size of the wires/cables for electrical wirings (fig. 3) so that the grommet perfectly adheres to the cable/wire. Do not cut the rubber grommets you're not going to use.
- 5) Put all the grommets in the pre-drilled holes of the box and drive the cables/wires (fig. 4).
- 6) Once wirings and installation are finished close the box and screw the cover on the box (fig. 5).

## 7. DISPOSAL



**Do not pollute the environment**

Some electronic components may contain polluting substances.

Ensure materials are passed to the authorised collection centres, according to the laws and the regulations on force, for safe disposal.

