

# MATRIX

## RACK-DRIVEN SLIDING GATE SYSTEM

---

Installation and User manual

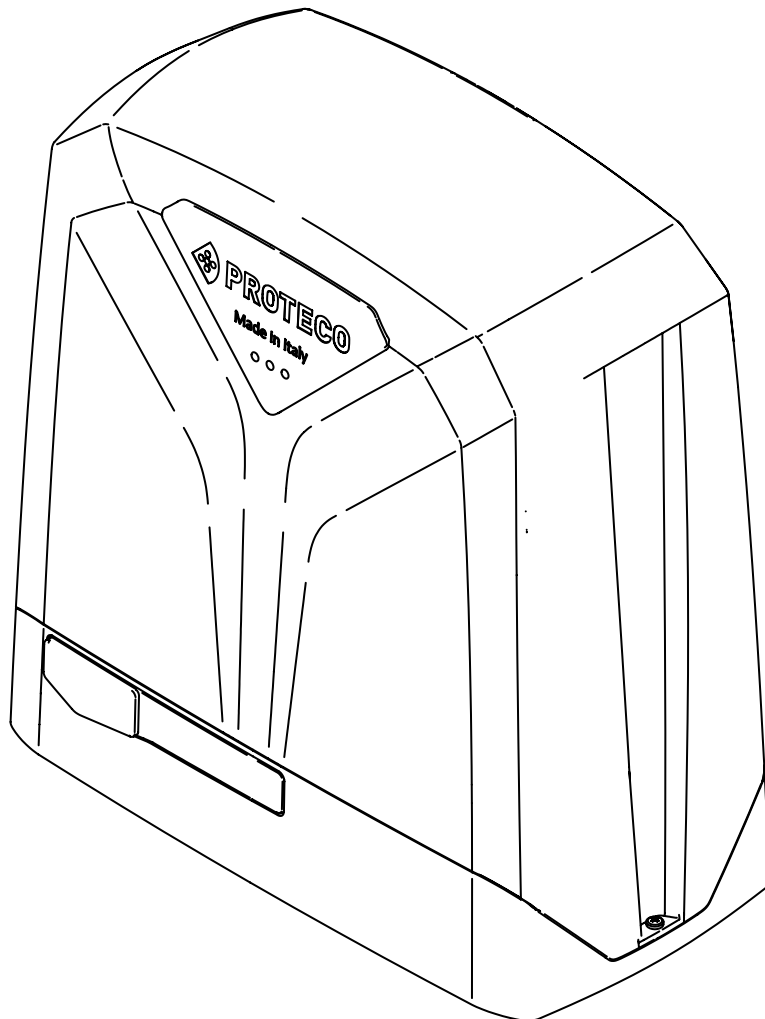

# INDEX

<b>1. WARNINGS</b>	<b>3</b>
<b>2. TECHNICAL FEATURES</b>	<b>3</b>
2.1 Introduction	3
2.2 Technical features	3
2.3 Content	4
2.4 Dimensions	4
2.5 Limit switches	4
2.6 Duty cycles	4
2.7 Life line	4
<b>3. INSTALLATION</b>	<b>5</b>
3.1 Introduction	5
3.2 Preliminary checks	5
3.3 Electric layout	6
3.4 Wires features	6
3.5 Basement preparation	6
3.6 Fixing on ground	7
3.7 Manual operation	7
3.8 Rack installation	8
3.8.1 B102 steel rack	8
3.9 Limit switches installation	9
3.9.1 Mechanical limit switches	9
3.9.2 Magnetic limit switches	9
3.10 Wirings	10
3.11 Master and Slave configuration	10
3.12 General test	10
3.13 Cabinet installation	10
<b>4. MAINTENANCE</b>	<b>11</b>
4.1 Release system test	11
<b>5. END USER GUIDELINES</b>	<b>13</b>
5.1 Safety tips	13
5.2 Manual operation	13
5.3 Maintenance	13
5.4 Disposal	13
5.4.1 Disposal of the system	13
5.4.2 Disposal of packing	13

## 1. WARNINGS

This manual for MATRIX series contains important information concerning personal safety.

An incorrect installation or an improper use may lead to severe injuries.

Read carefully and pay particular attention to the safety sections marked by the yellow triangle .



The installation of automatic doors, gates and barriers must comply with the Machinery Directive 2006/42/CE and EN 12453 regulation, and performed by qualified personnel.



Make sure the main power line is equipped with state of the art safety grounding system; as well be sure the whole installation is protected by a power cut switch and against overcurrent.

Make sure the area is clear from flammable gases and/or electromagnetic interferences: it could lead to very dangerous injuries.



Switch the power and batteries OFF before any operation.

After installation, packaging and waste materials (cardboard, plastic, metal parts etc.) must be kept away from children as they could be potentially harmful. Use only original spare parts. Any alteration to the system is prohibited.

Proteco Srl will not respond in case of using additional and/or fake spares.



Before commissioning the system, deliver the last pages of this manual to the user (section 5. END USER'S TIPS starting from page 13).

Proteco S.r.l. reserves the right to make changes to the product without notice.

## 2. TECHNICAL FEATURES

### 2.1 Introduction

MATRIX range is the new Proteco's electromechanical rack-driven motor generation designed to automate sliding gates in residential, block and industrial areas.

Any other use than that described is to be considered improper and prohibited.

All models grant the mechanical locking of the gate with an irreversible gear system; it is therefore not necessary to install any type of lock.

MATRIX works by electricity, in case of power cut the motor can be manually unlocked using a special lever system protected by key.

### 2.2 Technical features

	<b>Matrix 2500</b>	<b>Matrix 1800</b>	<b>Matrix BLDC</b>	<b>Matrix High Speed</b>
Power supply	230 V 50/60 Hz	230 V 50/60 Hz	230 V 50/60 Hz	230 V 50/60 Hz
Motor voltage	6 A	4,5 A	4,5 A	3 A
Start up current	2,5 A	2 A	1,4 A	1,3 A
Rated current	230 V 50/60 Hz	230 V 50/60 Hz	48 V dc	48 V dc
Rated power	550W	500W	350W	300W
Fuse	8A	8A	5A + 30A@48V	5A + 30A@48V
Start up capacitor	25 µF	30 µF	-	-
Standard capacitor	25 µF	20 µF	-	-
Start up thrust	2000 N	1400 N	1600 N	1400 N
Rated thrust	1100 N	900 N	1000 N	700 N
Thermal cut off	150°C	150°C	-	-
Max. opening speed	11 m/min	11 m/min	13 m/min	20 m/min
Max. leaf weight	2500 Kg	1800 Kg	2500 Kg	1800 Kg
Duty cycle	50%	50%	80%	80%
Operating temperature	-30° C ÷ + 55° C	-30° C ÷ + 55° C	-30° C ÷ + 55° C	-30° C ÷ + 55° C
IP rating	44	44	44	44
Limit switch type	Mechanical/ Magnetic	Mechanical/ Magnetic	Mechanical/ Magnetic	Mechanical/ Magnetic

## 2.3 Content

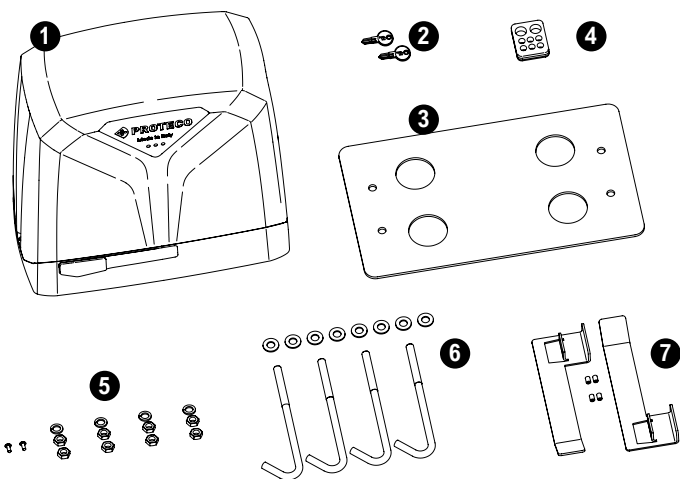

DESCRIZIONE	CODICE	QUANTITÀ
1 Gearmotor		1
2 Release key	FLC2722	2
3 Ground plate	MPIS06	1
4 Wires membrane	MPC06	1
5 Anchor screws Grower M10	MRO10EZ	4
5 Washer Ø 10		8
5 4,2x13 self-threading screws	MVI4213DI	2
6 Anchor screws i M10	MTRF10185Z	8
6 Bolt M10 + Washer M10	MDAM10Z	4
6 Washer M10	MRO10Z	8
7 Limit switch cam LH	MSLF01S	1
7 Limit switch cam RH	MSLF01D	1
7 Dowel M6x10	MGR0610Z	4

## 2.4 Dimensions

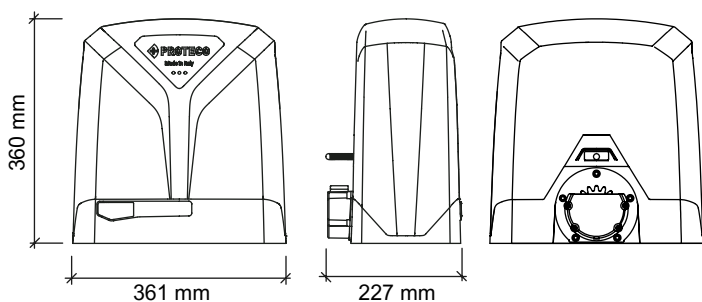

## 2.5 Limit switches

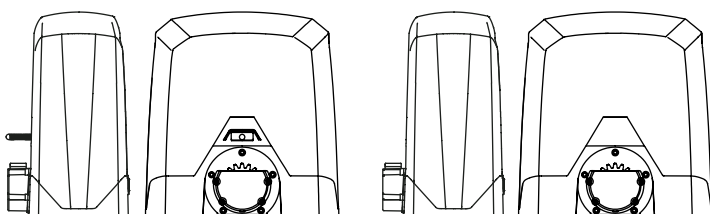

Picture 1: Mechanical limit switch

Picture 2: Magnetic limit switch

## 2.6 Duty cycles

The calculation of cycles refers to a gate of standard length, installed according to the standards in force, free from mechanical and/or accidental friction, with an outside temperature of 20 °C, as per EN 60335-2-103 regulations.

The number of working cycles depends very much on the length and weight of the gate, as well as the Matrix model chosen for the installation.

Table 1: Gate Length

	Matrix 2500	Matrix 1800	Matrix BLDC	Matrix High Speed
Gate length (m)	Max. Cycles/ Hour	Max. Cycles/ Hour	Max. Cycles/ Hour	Max. Cycles/ Hour
Up to 6	28	28	40	58
From 6 to 10	14	14	28	40
From 10 to 12	12	12	22	32
From 12 to 15	8	-	15	20
From 15 to 18	-	-	10	-

Table 2: Reduction of duty cycle rate according to gate weight

	Matrix 2500/ Matrix BLDC	Matrix 1800	Matrix High Speed
Gate weight	Duty cycle rate	Duty cycle rate	Duty cycle rate
600 Kg	100	100	100
From 600 to 1000	80	70	70
From 1000 to 1500	70	50	50
From 1500 to 1800	50	30	30
From 1800 to 2500	40	-	-

### Example:

Gate length 10 m, gate weight 1500Kg, Matrix 2500

14 x 0,7 (70%) = 9,8

Approximately 10 cycles per hour

In addition, there may be other factors that can affect the shelf life of the product.

Factors may vary depending on the environment in which the automation is installed.

## 2.7 Life line

The life of the gearmotor may be affected by multiple waste factors. The life expectation can be calculated using the criteria outlined in the below table.

In order to get the waste rate add together all values that comply with the installation scenario and according accessories.

### ATTENTION:

If the waste rate obtained is beyond 10, move to a superior version in order to fulfill the expected performances.

	Matrix 2500	Matrix 1800	Matrix BLDC	Matrix High Speed
Normal operation frequently cut due to obstacle	1	1	1	1,5
Seaside areas	1	1	1	1
Sandy and/or dusty areas	0,5	0,5	0,5	0,5
Outside temperatures often beyond 40° or below 0°	0,5	0,5	0,5	0,5

Gate weight	Matrix 2500/ Matrix BLDC	Matrix High Speed/ Matrix 1800
Up to 600 Kg	0,5	0,5
From 600 to 1000	1	2
From 1000 to 1500	2	3
From 1500 to 1800	3	4
From 1800 to 2500	4	-

Gate length	Matrix 2500/ Matrix BLDC	Matrix High Speed/ Matrix 1800
Up to 6 m	0,5	0,5
From 6 to 10	1	1
From 10 to 12	1,5	1,5
From 12 to 15	2	2,5
From 15 to 18	3,5	-

Follow the waste rate line of the graph to get the estimated duty cycles.

Duty cycles obtained may be compromised if the maintenance plan is not carefully respected.

Duty cycles are determined on the base of design analysis, project calculations and tests carried out at factory.

Therefore the duty cycles achieved are a mere estimation.

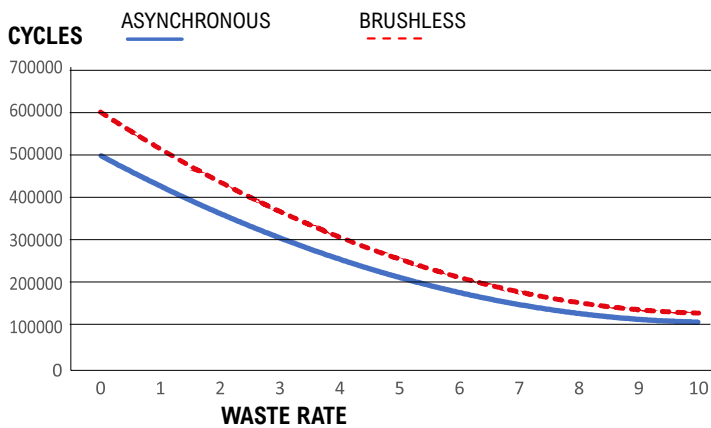

### 3. INSTALLATION

#### 3.1 Introduction



**Matrix must be installed by qualified personnel, complying with law regulations and instructions contained in this manual.**

For a proper installation, strictly follow the following procedure, respecting the below chronological order:

- Prepare a strong basement using ferro concrete.
- Fix the gearmotor to ground.
- Fit the rack and the according limit switches.
- Fit safety devices (sensors, blinker, safety edges ....)

#### 3.2 Preliminary checks

Before proceeding to installation, it is necessary to double check the good condition of every component and make sure the site is suitable for installation purposes.

- All components must be integral and suitable to use.
- Make sure the installation site complies with system's dimensions.
- Make sure the concrete basement grants stability and solidity.
- Make sure the area around the system is clear enough to allow easy and safe manual operation.
- Make sure gate features are suitable to automate.
- Make sure weight, dimensions and gate features are suitable to the model you have chosen.
- Make sure cogwheel case doesn't hit against any fixing points of the gate (as screws, bolts, gate's wheels).
- Make sure the gate area is fitted with ground stops both in opening and closing.
- Make sure the installation area grants fixing stability and solidity.
- Make sure the gate is mechanically free of friction.
- Make sure the automation fixing area is compatible with the dimensions of the ground plate and that there is sufficient space to carry out manual operation easily and safely.
- Make sure the automation positioning area is not subject to flooding; possibly install the automation raised from the ground.
- If the system is installed in areas where vehicles transit, it is advisable to provide adequate protection against accidental impacts.
- Make sure the electric circuit is connected to a state of the art safety grounding.
- Make sure the fixing surfaces of the photocells are flat and allow correct alignment between transmitter and receiver.

### 3.3 Electric layout

Picture 3: Electric layout

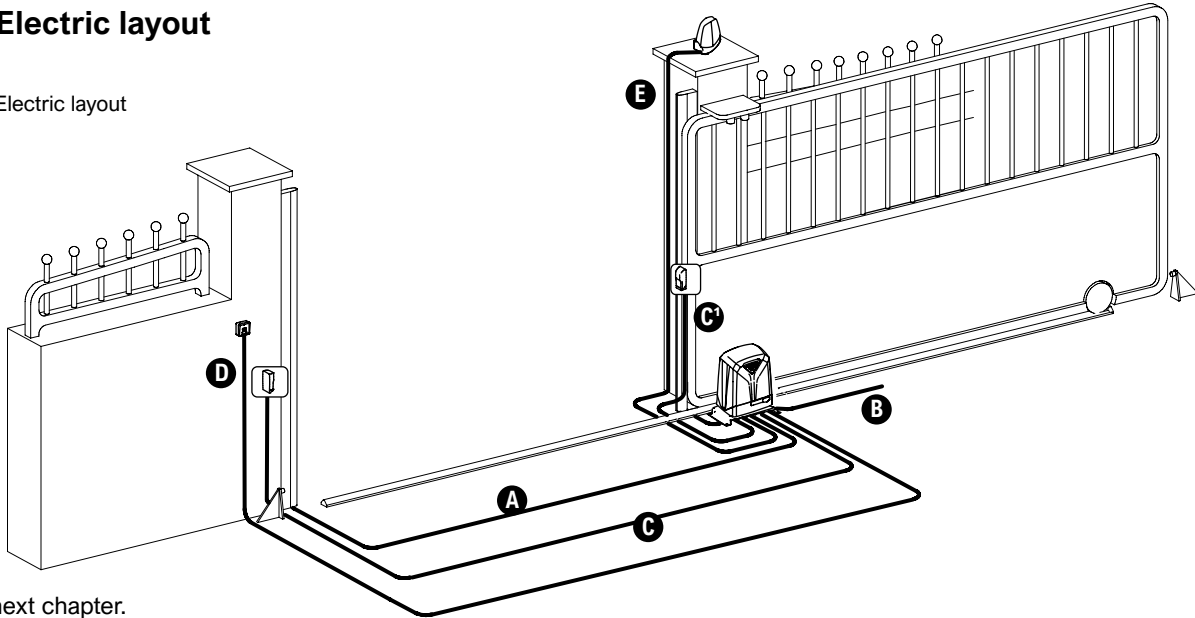

Refer to next chapter.

### 3.4 Wires features

Cables necessary for the installation of the system (not included) may vary according to the quantity and type of accessories and devices fitted.

	230V	24V
<b>A</b> Safety edge	2x0,5	2x0,5
<b>B</b> Power supply	2x1,5+T	2x1,5+T
<b>C</b> Photocells	Rx 4x0,5	Rx 4x0,5
<b>C</b> Photocells	Tx 2x0,5	Tx 2x0,5
<b>D</b> Key switch	2x0,5	2x0,5
<b>E</b> Blinker	2x0,5	2x0,5

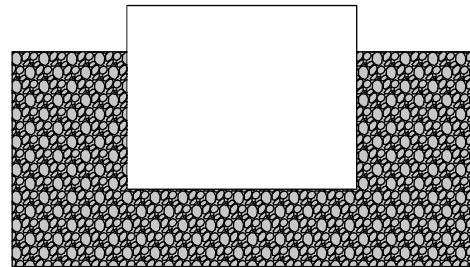

Picture 5: basement section

Pay attention while arising the basement, since **the concrete work cannot impede to stud the fixing screws.**

**Do not forget wirings!** While preparing the concrete basement keep a duct of the proper dimension to connect the main power and any possible additional devices. Drive the wires guide through the right hole of the ground plate and keep it oriented towards the property. Make sure ground plate is properly levelled. **(Picture 6)**

### 3.5 Basement preparation

It is absolutely key to build a solid concrete basement (at least EN206 C25/30 proof). Basement dimensions must be no less than 500x300mm and no less than 400mm deep. We recommend to consider an extra concrete surface of 100 mm all around the basement. **(Picture 4)**.

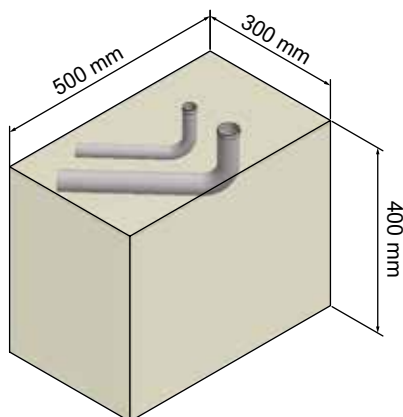

Picture 4: ferro concrete basement

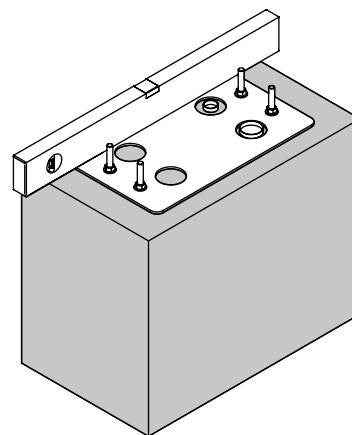

Picture 6: Basement and ground plate

Picture 7: Top view

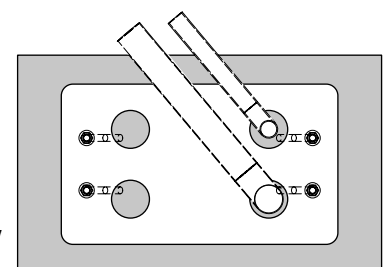

PROPERTY VIEW

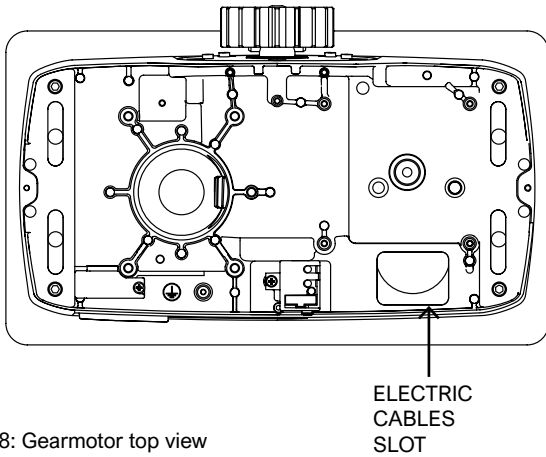

Picture 8: Gearmotor top view

Screw nut and washer M10 to the anchor bolts, keeping the same distance for all of them, in order to create a balanced support for the ground plate.  
Put anchor bolts M10 into holes, then tighten washers and bolts M10 as shows **Picture 10**.

Picture 9:  
Ground plate view

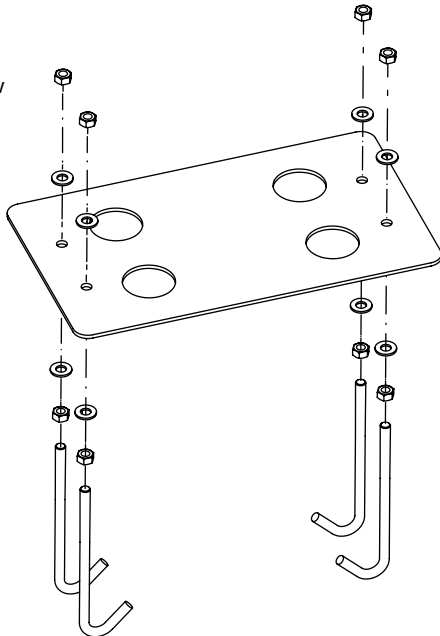

Picture 10: Anchor screws view



Cast the concrete and, before setting begins, put the ground plate in the center, leaving a margin of 40/60mm; ground plate has to be aligned to the gate and properly levelled.  
Wait for the concrete to set completely.

**ATTENTION: Keep the ground plate surface and anchor bolts as clean as possible (screen the anchor bolts).**

Leave electrical cables at least 30-50cm longer to allow easy connection to the control unit.

### 3.6 Fixing on ground

Loose washers and bolts M10 screwed on the ground plate.  
Proceed to remove Matrix's cabinet.

Lay the gearmotor on the ground plate.

Match anchor bolts protruding from the ground plate to the aluminium base slots.

Fix the gearmotor to ground plate using flat washers M10, Grower washers and bolts M10 provided in the fittings bag.  
Pay attention while fixing, cogwheel must be oriented towards the gate.  
**Attention!** Drive electric cables through the aluminium base and keep them away from components that may warm up (as motor, transformer, etc etc).

Cut the membrane keeping an extra margin of 3 cm from ground plate edge and fit the cables for safety devices and power supply connection.

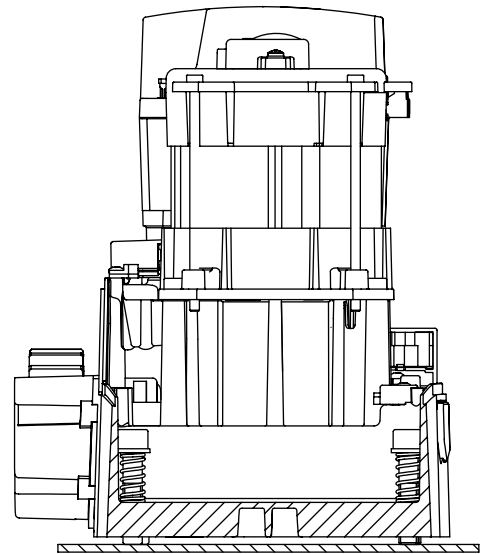

Figure 11:

It is possible to adjust the height of the aluminium base calibrating the 4 screws 10x50 and springs (this will be necessary only if Matrix serves as replacement of a previous installation, refer to **picture 11**)

Height can be adjusted up to max. 19mm (without washer).  
Unlock the gearmotor and set it to manual operation mode.

### 3.7 Manual operation

Switch the power off and release the gearmotor using the lock barrel positioned on the aluminium base.

Lift the plastic tang to accede to the lock (**Picture 12**).  
Plug the key in and turn it counter clockwise.

Pull the release lever completely to full opening (90°), (**Picture 13**).  
Now you can move the gate manually.

**ATTENTION: Be carefull, the gate may accidentally move.**

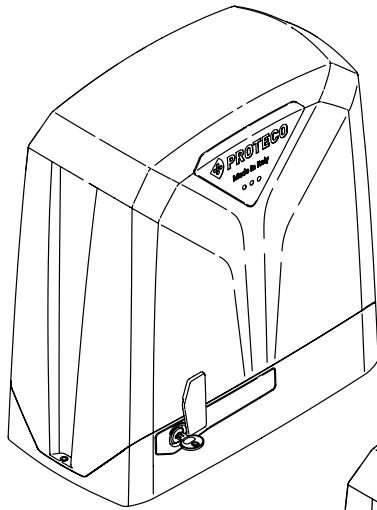

Picture 12- Lock barrel

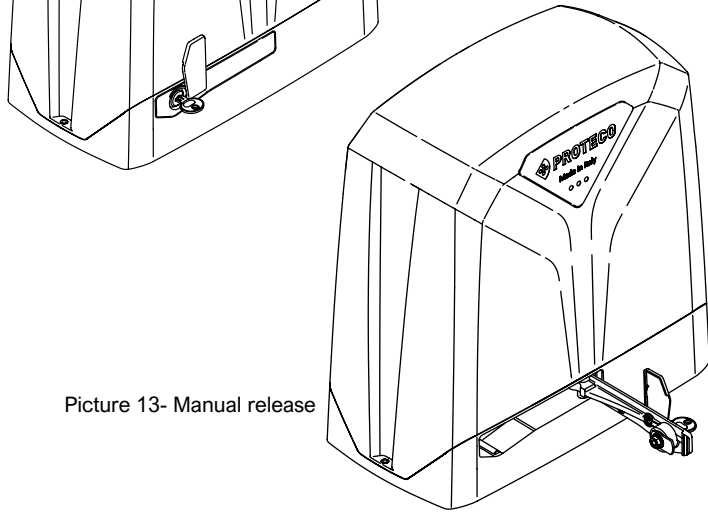

Picture 13- Manual release

To lock the gearmotor back, put the release lever to its original closing position and turn the key clockwise (Picture 12).

Remove the key from the barrel and pull down the plastic tang.

Move the gate to restore the lock system.  
Power the gearmotor.

### 3.8 Rack installation

#### 3.8.1 B102 steel rack - type M4 12x30mm - 1m length

**ATTENTION:**

Fit the rack as shown in the below picture.

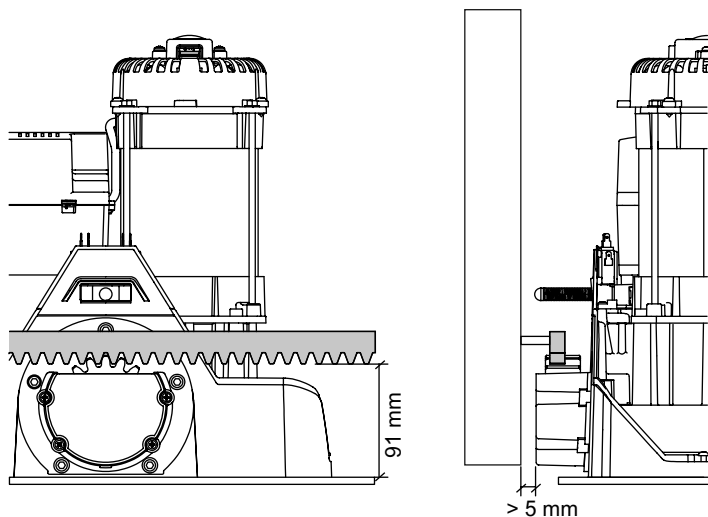

Manually move the gate to opening position.  
Fit the three bolts to the rack in the centre of each slot (Picture 14).

Rack has to be aligned to the gate.

While positioning the rack, keep a small gap between rack and cogwheel of 1/2mm and level. Weld the first bolt to the gate.

Move the gate manually making sure the rack properly matches the cogwheel, then weld the second and third bolt.

Place another rack piece beside, using another one underneath for calibration. See Picture 15

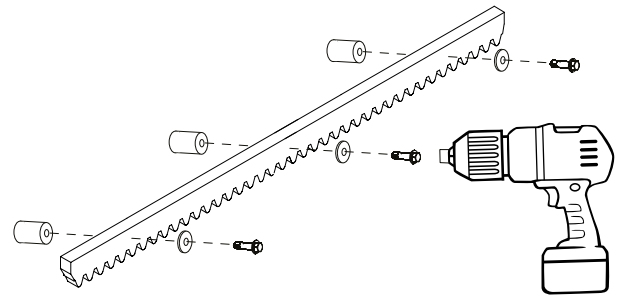

Picture 14- Rack installation

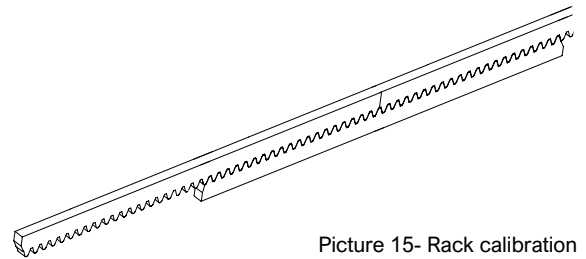

Picture 15- Rack calibration

Move the gate manually and weld the three bolts.  
Close the gate manually for about 0,5 m, and join the second rack piece to the first one, keeping match to the cogwheel.

Make sure rack is properly levelled and fix.



Picture 16: - Extension bracket

Repeat the same procedure for the whole gate's length.  
The last rack piece may exceed the gate length: in this case add a bracket as gate extension and as rack support (Picture 16).

**ATTENTION:** Make sure the gate regularly reaches mechanical ground stops keeping match between rack and cogwheel.  
Make sure as well the gate is free of friction points during cruising.

**IMPORTANT:** Avoid the gate overloads the gearmotor.  
Keep a small gap between the rack and the cogwheel (Picture 17).

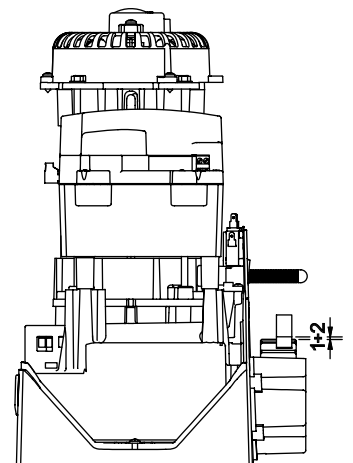



### 3.9 Limit switches installation

#### 3.9.1 Mechanical limit switches

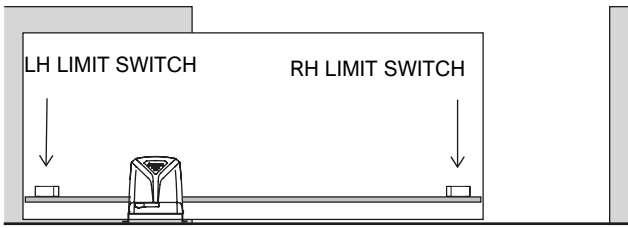

Picture 18

Once the motor position is determined, adjust limit switches accordingly. (Picture 18)

- Manually close the gate and keep a margin of 3 cm before reaching the closing mechanical stop.
- Fit the two dowels to the limit switch cam.
- Lean the cam and slide until the limit switch is activated.
- Tighten the dowels to secure the cam to the rack.
- Manually move the gate to opening position and repeat the same procedure.
- Take the dowels and fix the limit switch cams.

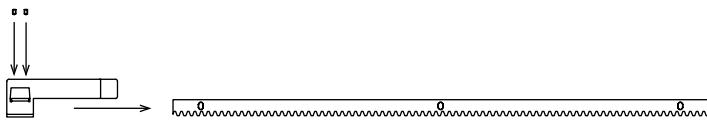

Picture 19: Cam installation on rack

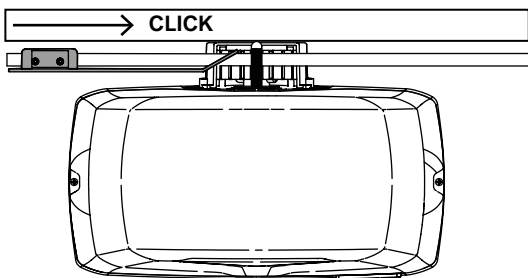

Picture 20

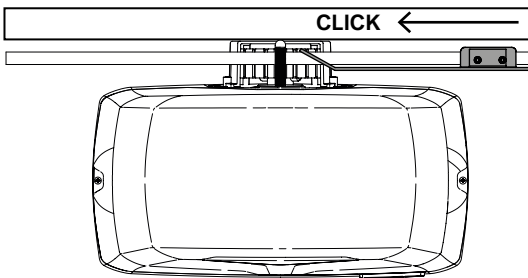

Picture 21

Once the installation of the limit switch cams has been completed, manually move the gate in opening and closing and check that cams always activate the limit switch without reaching the mechanical stop. (Pictures 20/21)

This check guarantees the correct functioning of the automation and preserves the good mechanical condition of the gate.

**ATTENTION: Remove any exceeding rack.**

#### 3.9.2 Magnetic limit switches

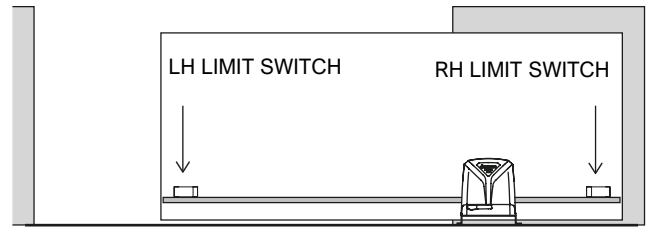

Picture 22

Once the motor position is determined, adjust limit switches accordingly. (Picture 22)

- Manually close the gate and keep a margin of 3 cm before reaching the closing mechanical stop.
- Fit the two dowels to the closing limit switch cam.
- Lean the cam and slide until the limit switch is activated.
- Tighten the dowels to secure the cam to the rack.
- Manually move the gate to opening position and repeat the same procedure.
- Take the dowels and fix the limit switch cams.

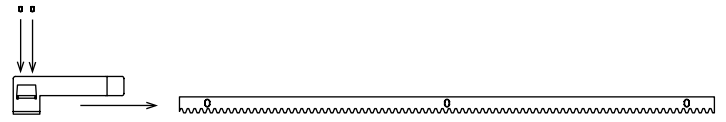

Picture 23: Cam installation on rack

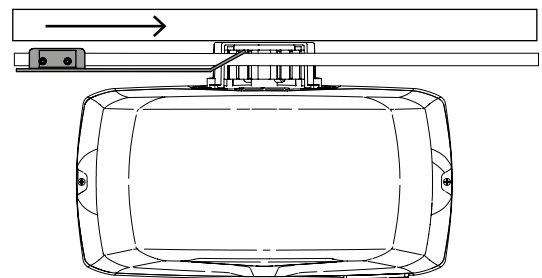

Picture 24

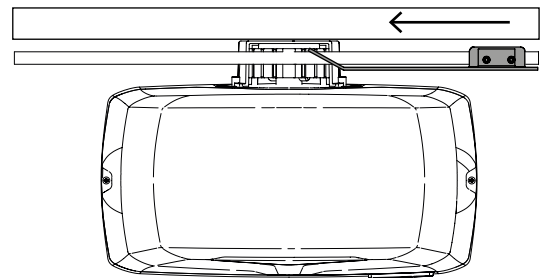

Picture 25

Once the installation of the limit switch cams has been completed, proceed to general test. (Pictures 24/25).

This procedure guarantees the correct functioning of the automation and preserves the good mechanical condition of the gate.

**ATTENTION: The magnetic limit switch is activated when approaching the magnetic area. Leave the gear and control unit visible to double check the good operation of the system.**

**ATTENTION: Remove any exceeding rack.**

### 3.10 Wirings



The power connection must be performed by experienced qualified personnel, in full compliance with laws, rules and regulations.

Insert the electrical cables into the supplied cable gland, breaking through the membranes and place the cable gland in the appropriate seat on the base of the gearmotor.

Connect all power and grounding cables to the appropriate terminal block located near the symbol

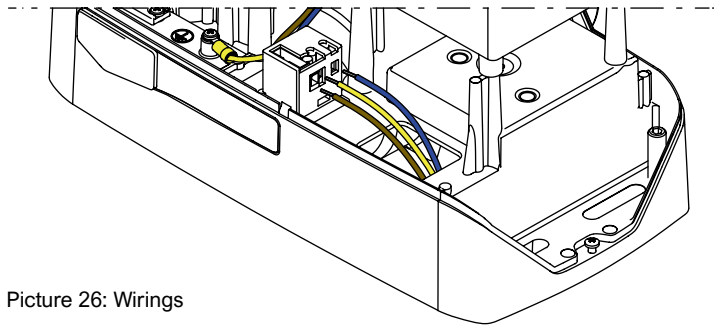

Picture 26: Wirings

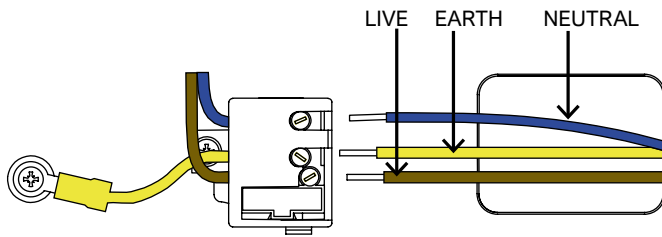

Picture 27: Wirings terminal block

### 3.11 Master and Slave configuration



Picture 28: TWIN mode - full opening

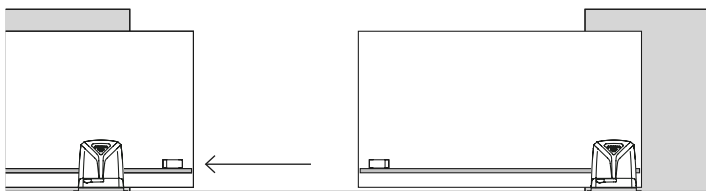

Picture 29: TWIN mode - pedestrian/partial opening

PARTIAL/PEDESTRIAN start command is performed only by MASTER motor.

The TWIN function allows to synchronize two mirror sliding gates as shows **Picture 28**.

For more details refer to chapter "TWIN mode".

### 3.12 General test

Before starting the general test, be sure programming has been carried out (Refer to chapter "3.5 Start Up" of the control unit manual).

Once mechanical installation and electrical connections have been completed, power the automation and proceed with a careful test of the gearmotor, accessories and safety devices connected.

**Important! Programming procedure must be repeated every time anything concerning the gate has been changed (speed, weight, rail, wheels ...)**

Most importantly, check that opening and closing limit switches work correctly, stopping the gearmotor before it reaches the mechanical stops.

After powering the gearmotor, manually move the leaf to opening and closing position and check that LO (Opening limit switch) and LC (Closing limit switch) are displayed on the control unit before reaching the mechanical stop. Make sure both messages are properly displayed.

Deliver the end user chapter of this manual to the customer and instruct him how the automation works and how to use it.

### 3.13 Cabinet installation

Once both mechanical and electrical installations are completed, proceed to fit the cabinet.

Lean the cabinet onto the alluminium base, just put a little pressure on the upper side. Use the two screws 4,2x13 to fix the cabinet, as show **Pictures 30 and 31**.

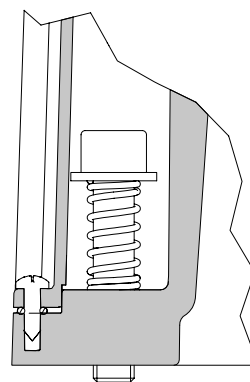

Picture 30: Matrix section view

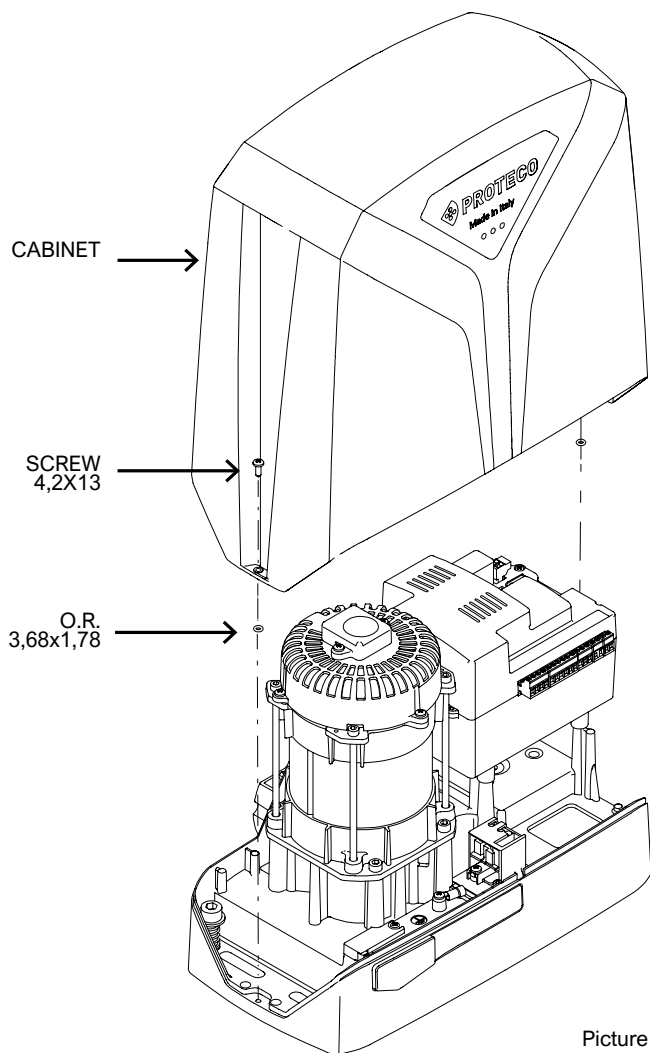

Picture 31

## 4. MAINTENANCE

**Attention! Maintenance service must be carried out by qualified technical personnel, in full compliance with the safety standards required by the laws in force. Maintenance has to be carried out every six months.**

Regular maintenance is required to keep the automation safe and in good operation over time.

In order to proceed to maintenance service, follow the below checks:

- Turn the POWER OFF.
- Check screw connections are properly tightened.
- Check the condition of moving components: cogwheel, rack and gate parts.  
Proceed to replace the wasted parts.
- Turn the POWER ON and proceed to the expected tests outlined in the chapter.
- Lock the gearmotor back and proceed to test.

### 4.1 Release system test

To check the efficiency of the release system, perform the following checks.

Disconnect any power source, use the supplied key to release the lock barrel on the aluminium base.

Pull the release lever and move the gate manually to check proper operation.

Gate leaf must slide freely during the whole cruise.



## 5. END USER GUIDELINES

The following pages contain important information for your safety and for complying with standing safety regulations. Keep this manual for future reference.

### 5.1 Safety tips



Keep children under 8 away from the system.



Children over 8, people with reduced physical or mental abilities, or lacking experience, may only use the automation under supervision, or if they have been instructed on how to use safely the system and have understood the related dangers.



This product was designed and built exclusively for the intended use indicated. Any other use could compromise the integrity and safety of the product and should be avoided.



Do not access, for any reason, the internal parts of the automation: it may be dangerous and components can only be repaired or replaced by qualified personnel.



Do not start transmitters or other command devices unless the area is visible and clear from danger.



Do not allow children play within the automation area.

### 5.2 Manual operation

To release the gearmotor use the lock barrel positioned on the aluminium base. Lift the plastic tang to accede to the lock (Picture 32).

Plug the key in and turn it counter clockwise. Pull the release lever completely to full opening (90°), (Picture 33). Now you can move the gate manually.

**ATTENTION: Be careful, the gate may accidentally move.**

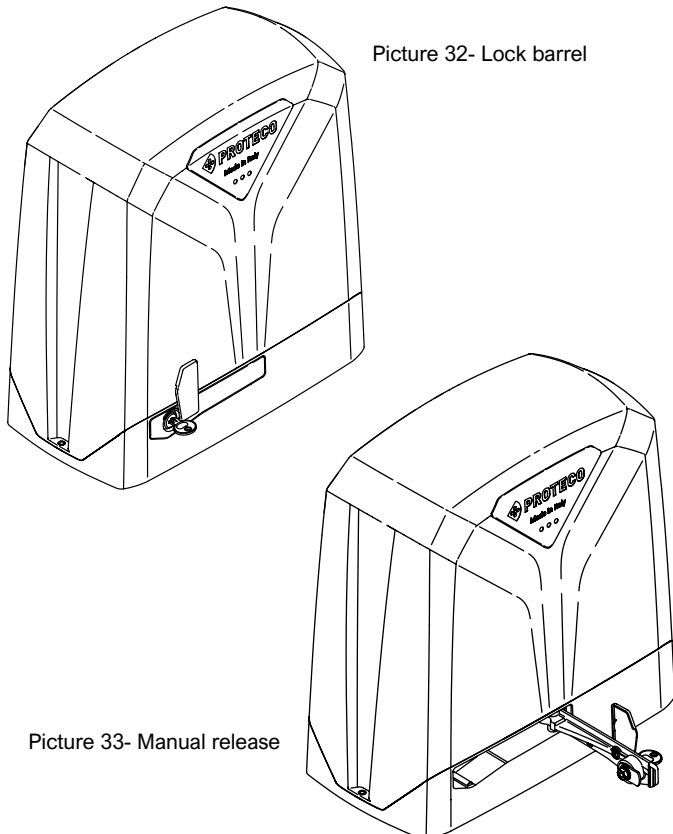

Picture 32- Lock barrel

Picture 33- Manual release

To lock the gearmotor back, put the release lever to its original closing position and turn the key clockwise (Picture 32).

Remove the key from the barrel and pull down the plastic tang. Move the gate to restore the lock system.

**ATTENTION: put the gate exactly in the same previous position, or switch the power off during 5/10 seconds and then turn the power on again.**

**ATTENTION: store key and installation manual in a safe place for future reference.**

### 5.3 Maintenance

To keep the automation safety and in good operation over time, it is advisable to schedule a periodic maintenance plan with the installer, or at least report any anomalous behaviors that may require inspection.

**In case of malfunctions it is advisable to contact the installer who carried out the whole installation, rather than others.**

Periodic maintenance and repairs must be reported by the installer and the owner must keep them safe and available for future reference. End user may only take care of photocells and automation housing cleaning.

### 5.4 Disposal

#### 5.4.1 Disposal of the system

Any part of the system, including devices such as remote controls, must be disposed in compliance with current legislation, as they may be harmful for the environment.

Most of the materials used are similar to solid urban waste and can be handled accordingly. They can be recycled through separate collection and disposed in authorized centers.

Other components (electronic boards, batteries, etc.) may instead contain polluting substances. They must therefore be removed and delivered to companies authorized for their recovery and disposal. Before proceeding, it is always advisable to check the specific regulations in force.

#### 5.4.2 Disposal of packing

Packaging components (cardboard, plastics, etc.) are sare similar to solid urban waste and can be handled accordingly without any difficulty, simply by carrying out separate collection for recycling. Before proceeding, it is always advisable to check the specific regulations in force.



**DO NOT POLLUTE THE ENVIRONMENT!** Some components may contain polluting or dangerous substances, if dispersed they could affect the environment and human health.



**Proteco S.r.l.** Via Neive, 77  
12050 CASTAGNITO (CN) ITALY  
Tel. +39 0173 210111 - Fax +39 0173 210199  
info@proteco.net - www.proteco.net