

13

TWO WIRE DIGITAL SYSTEMS

ACI/FARFISA
INTERCOMS

TECHNICAL
MANUAL
2005

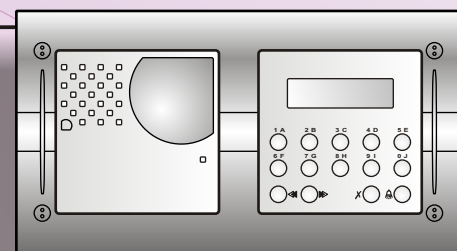

PROJECT
MATRIX

DUO system

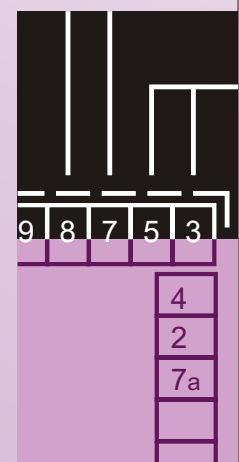
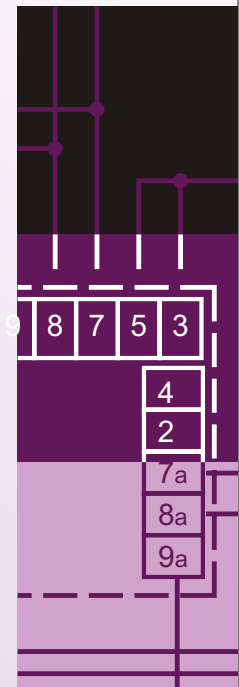

INTRODUCTION

This edition contains helpful information on the operation and installation of Farfisa video intercoms systems.

In order to make the systems work properly it is necessary to install only Farfisa equipment, keeping strictly to the items referred to in each diagram.

Read all the notes carefully, (even the small ones) in each installation scheme and the working instructions of the system given in the following pages.

For the sake of clarity, please notice that the sequence of the terminals of each article has not been followed. Only the terminal code (letter and/or number) is valid not the graphic sequence.

The items may have more terminals than the ones in the installation diagrams. The excess terminals must not be used.

Notice to the installer and user

Check the integrity of the product after removing it from the packing.

Packing materials (such as plastic bags, cardboard, polystyrene foam, etc.) must be kept out of the reach of children.

The manufacturer cannot be held responsible for possible damages caused by improper, erroneous and unreasonable use.

The cable runs of any intercom and video-intercom system must be kept separate from the mains or any other electrical installation as required by **International Safety Standards**.

WARNINGS

An all-pole mains switch with a contact separation of at least 3mm in each pole shall be incorporated in the electrical installation of the building.

Before connecting the unit, make sure its data correspond to those of the mains.

The apparatus shall not be exposed to dripping or splashing.

For correct operation make sure that ventilation or heat dissipation openings are not obstructed.

Do not open or tamper with power supply or video intercom apparatus when they are ON. There is high voltage inside.

Avoid bumping and hitting the video intercom apparatus, it could break of the CRT with consequent projections of fragmented glass.

For installation or maintenance refer only to qualified personnel.



European Mark of conformity to the EEC Directives.

CEMARK

The CE mark ensures that the product complies with the requirements of the European Community Directives in force; in particular, Electrical Safety LVD73/23, Electromagnetic Compatibility EMC89/336 and Telecommunication Terminals R&TTE99/5 Directives.

As set forth by the Directives, the technical documentation and Conformity Declarations are available in the Company's offices for verifications and controls by competent Authorities.



Mark of VDE a German Testing and Certification Institute.



Quality assured firm according to standard ISO 9001:2000 certified SGS.



Italian Association of Electrotechnical and Electronic Industries

Due to continuous technological evolution ACI FARFISA reserves the right to modify the products, technical specifications and installation diagrams contained in this manual at any time without prior notice.

The diagrams and information contained in this manual have been carefully verified and are to be considered as reliable. However, ACI FARFISA is not responsible for any errors, inaccuracies or infringements to patents and third-party rights that may arise from using this manual.

13 TECHNICAL MANUAL

2005 edition

<i>INDEX</i>	<i>Page</i>
Main features	2
Internal stations	3
- video intercom Project series	3
Door stations	6
- push-button panel Matrix series	6
Power supplies	22
Installation instructions	23
Installation diagrams	25
Product list	
2220. Transformer for door stations	22
2221. Transformer for line driver	22
2222. Line driver	22
2302. Cable with 2 conductors	23
DV2421. Line distributor	22
CD2132MA. Digital encoder module with 2 call buttons. Matrix series	11
CD2134MA. Digital encoder module with 4 call buttons. Matrix series	11
MA20. Blank module Matrix series	6
MA22S. Module with 2 call buttons. Matrix series	16
MA24S. Module with 4 call buttons. Matrix series	16
MA61. Front frame for 1 module. Matrix series	6
MA62. Front frame for 2 modules. Matrix series	6
MA63. Front frame for 3 modules. Matrix series	6
MA71. Back box with frame for 1 module. Matrix series	6
MA72. Back box with frame for 2 modules. Matrix series	6
MA73. Back box with frame for 3 modules. Matrix series	6
MA91. Rain shelter with frame for 1 module. Matrix series	6
MA92. Rain shelter with frame for 2 modules. Matrix series	6
MA93. Rain shelter with frame for 3 modules. Matrix series	6
PT5262W. Video intercom with integrated decoder. Project series	2
TD2100MA. Digital push-button panel. Matrix series	7
VD2120MA. Audio/video module. Matrix series	7
WB5262. Wall bracket for PT5262W video intercom	3



MAIN FEATURES

Farfisa digital **DUO System**, developed with innovative technology, allows the installation of videointercom systems up to 40 users and 2 door stations, drawing **two non-polarized wires only**, including the power supply to the system. The very reduced number of conductors with no coaxial cable allows a fast and simple videointercom installation, reducing mounting costs. The 2-wire technology allows a videointercom system, with 1 or more entrances, without having to think of the calculation of the conductors on the riser and on the various branches; the wires are always two. For a good result of the installation it is necessary to follow carefully the indications in this manual and especially it is requested not to exceed the distances recommended by ACI Farfisa.

Choosing the equipment

The following options are available for **door stations**:

- door stations with digital push-buttons panels
- door stations with conventional push-button panels and digital encoder

The **internal stations** are videointercoms with flat tube and integrated decode module. The videointercom is connected to the wall bracket through terminal boards.

Performances of DUO videointercom installations

- digital or conventional push-button panels with digital encoder
- coded call with 12-button keypad on 2x16-character LCD
- call by means of conventional buttons with digital encoder
- call from landing or intercommunicating is differentiated from the outdoor one
- timed conversation (1-minute duration with possibility of increasing conversation time by pressing a specific button on the push-button panel)
- acoustic signal of conversation end
- private audio-video and lock function (only the called user can see, talk and release lock)
- coded lock release directly from the digital push-button panel (by means of programmable personal code)
- busy signal on door stations
- free tone on internal stations when the installation is available for intercommunicating calls or video auto switching
- connection up to 5 internal stations in parallel and intercommunicating for each user

Installation examples

Installation example of a videointercom system with one video digital station

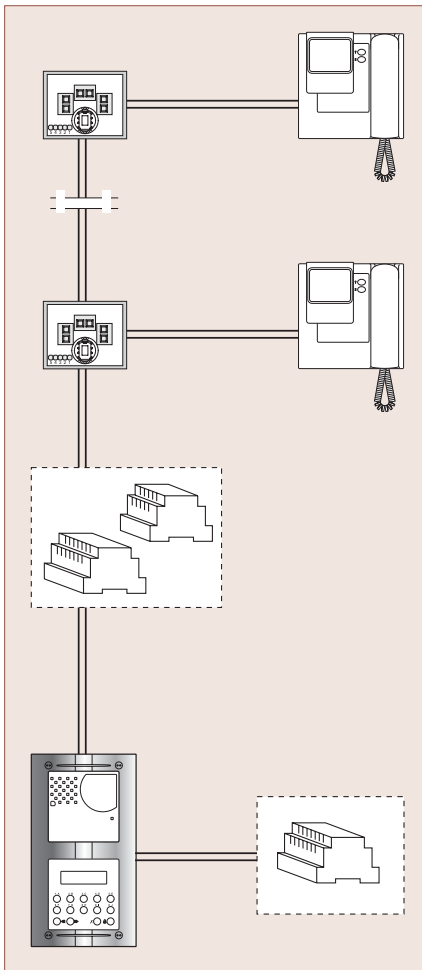

Installation example of a videointercom system with two video digital stations and two risers

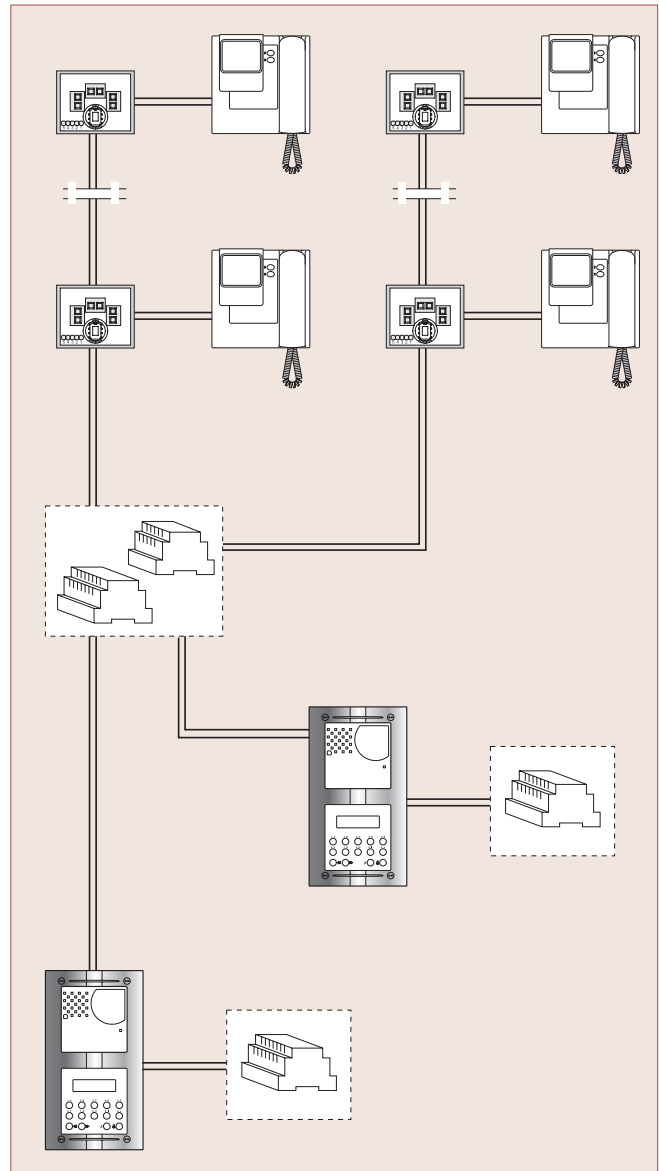

INTERNAL STATIONS

VIDEOINTERCOMS WITH INTEGRATED DECODER

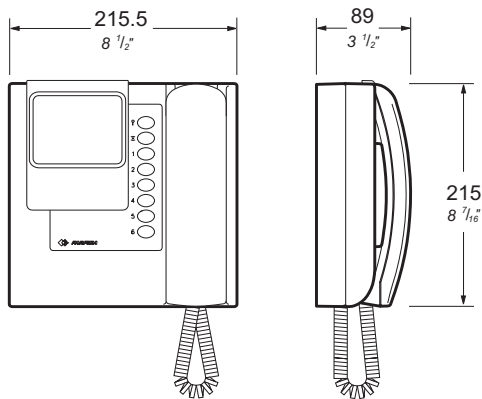

PT5262W. White flat tube videointercom with two buttons, one for control switch ON and one for door lock release, audio-video privacy, electronic microphone, modulated electronic ringing sounds and terminal board for the connection to the wall-bracket. It can be installed on the wall (with no built-in) by using the wall-bracket **WB5262**.

WB5262. The wall bracket for the **PT5262W** video intercom includes a terminal board for connection to the system.

Technical characteristics

Power supply directly from the line

Local power supply:	13Vac/15Vdc
Stand-by current:	8 mA
Operating current	0.6A
Screen	4" FLAT CRT
Starting up time	2 ÷ 4 sec.
Operating temperature	0° ÷ +50°C
Maximum admissible humidity	90% RH

Terminals

- LM/LM** Line inputs
- A+** Local positive power supply (15Vdc-13Vac)
- A-** Local negative power supply
- P1/P1** Contact of push-button n.6 (max 0.3A)
- A1** Floor call positive input
- GN** Floor call negative input
- GPC** Additional bell positive output
- GPE** Additional bell negative output

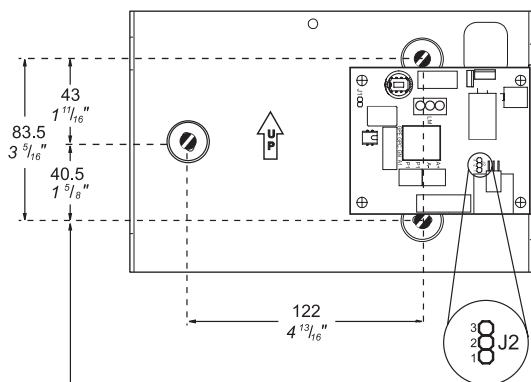

140 ÷ 150 cm
4' 7" ÷ 4' 11"

Measures for the installation of the wall bracket **WB5262** to the wall, and recommended height from the floor.



J2 Jumper to select the power supply of videointercom



1-2 powered locally (A+/A-)

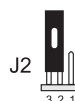

2-3 powered by the line (default)

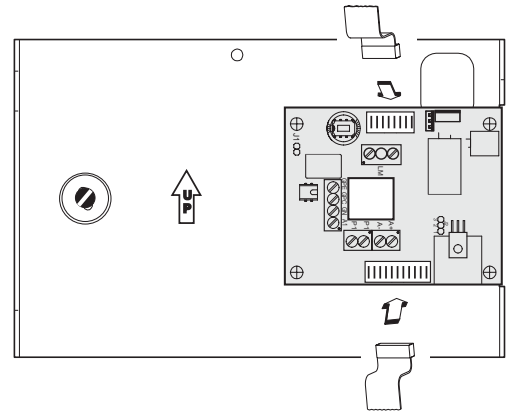

Plugging in of videointercom connectors to the terminal boards of wall bracket.

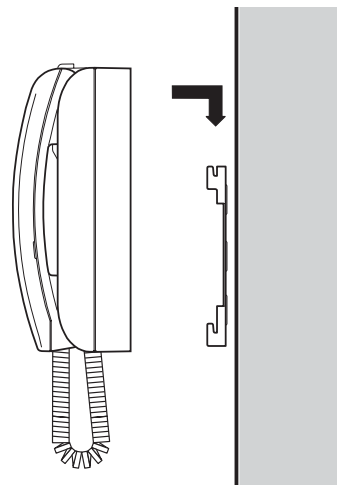

Installation of videointercom onto the wall bracket.

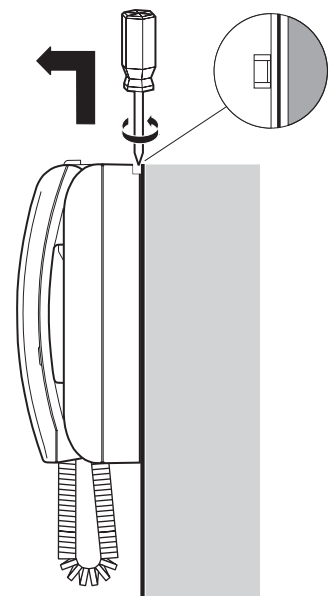

Dismounting of videointercom from the wall bracket.



INTERNAL STATIONS

Programming



Monitor must be programmed properly to define its operating mode. Function that can be programmed are:

- **User address** (mandatory; default value is 100).
- **User address for intercommunicating functions** (mandatory; default value 000).
- **Code for supplementary push-buttons** (not mandatory; any value by default).
- **Bell volume** (two level adjustment; high-low).

Programming procedure

To enter or exit from the programming phase it is necessary to do the following steps:

Enter the programming phase

- With the handset hanged up press the button  until you get the programming tone.
- Pick up the handset still keeping pressed the button  until you get the confirming tone.
- Keep the handset out of the hook and proceed with the programming.

Exit the programming phase



- Hang up the handset.
- To protect the programming phase, any operation not allowed or wrong will cause the immediate exit from the programming phase.

Keypad meaning

- To enter addresses or codes you must use the buttons P1÷P5 as described in the following table.
- To enter numbers from 1 to 5 uses buttons P1÷P5.
 - To enter numbers from 6 to 0 uses the shift button  followed by the buttons P1÷P5.

Monitor buttons cross-reference

P1 = 1	 +P1 = 6
P2 = 2	 +P2 = 7
P3 = 3	 +P3 = 8
P4 = 4	 +P4 = 9
P5 = 5	 +P5 = 0

Example: to enter the code 028 it is necessary to press in sequence: +P5/P2/+P3

Programming of user's and intercommunicating address

- In order to receive a call from the door station the monitor must be programmed with an address which is stored in a non-volatile memory. To program the monitor it is necessary to:
- Enter the programming phase.
 - Press the button  until a programming tone will be heard.
 - Enter the user's address (the value must be between 001 and 200; do not forget to enter always all the three figures. After entering the third figure, if the value is correct, a confirming tone will be heard).
 - Enter the internal user address for the intercommunicating function (the value must be between 000 and 005; do not forget to enter always all

the three figures. After entering the third figure, if the value is correct, a confirming tone will be heard).

- If you desire to go on with the programming phases proceed, otherwise exit the programming phase, as described in the previous paragraphs.

Programming the codes to assign to the supplementary push buttons

To use the supplementary buttons to call another user, to make an intercommunicating call inside the same apartment, or to make a connection with an external door station it is necessary to program them according to the following instructions:

- Enter the programming phase as described in the previous paragraphs.
- Press the buttons you want to program (P1÷P5) until you hear the programming tone.
- Enter the code you will associate to the button
- To call a monitor in the same apartment and intercommunicating enter always the code 000 (after entering the third figure, if the value is correct, a confirming tone will be heard). The value of the button P1÷P5 will set automatically the address of the monitor to call according to the following table.

Intercom- municating user	Button to press				
	P1	P2	P3	P4	P5
000	001	002	003	004	005
001	000	002	003	004	005
002	000	001	003	004	005
003	000	001	002	004	005
004	000	001	002	003	005
005	000	001	002	003	004

For example if you press the button 3 from the monitor whose intercommunicating address is **002** you will call the intercommunicating user **003**.



- To call another user enter is address (value between 001 and 200; do not forget to enter always all the three figures. After entering the third figure, if the value is correct, a confirming tone will be heard).
- To be connected with an external door unit enter is address (value between 231 and 240; do not forget to enter always all the three figures. After entering the third figure, if the value is correct, a confirming tone will be heard).
- If you desire to go on with the programming phases proceed, otherwise exit the programming phase, as described in the previous paragraphs.

Programming the volume of the bell

- In order to modify the bell level, you have to:
- Go to the programming mode as described in the previous paragraphs.
 - Press the lock button to change the level (from high to low and viceversa), The videointercom shall confirm the operation with a tone which sound level is equal to the recorded bell level.

Operating mode

Call or connection with an external door station.

When a call is originated from an external station you get an acoustic signal on the monitor and it powers ON for about 30 seconds; if the calling time expires and the monitor turns OFF you can press the buttons  to establish again the connection with the calling external door station. Picking up the handset you install a connection with the door station for about 90 seconds, and pressing the button  you will open the door.

When you pick-up the handset with the system without any conversation in progress, you will get a tone of free system, pressing the  button you will be connected with the external door station or the last calling external station if more than one door stations are present on the system: in this case, if the buttons P1÷P5 on the monitor have been programmed with the address of the external stations, it would be possible to connect selectivity with them by pressing the related buttons.

If picking up the handset you did not get any tone, the system is busy, and no other operations are allowed until the system become free.

In the case of a call to an apartment which has more than one monitor in parallel, intercommunicating service, all the monitors (max 6) will ring, but only the monitor whose intercommunicating address is 000 will be powered ON; to answer from this video intercoms you can proceed as described in the previous paragraphs. From other monitors it would be possible to answer just picking up the handset, this operation lights ON automatically the monitor from which you answer and powers OFF the previous one lighted ON.

If you wish to see whose is calling before answering, you can press the  button and then pick up the handset.

Control power ON.

When the system is in stand by mode and no communications are in progress, it would be possible from an apartment to make a control power ON function by pressing, without picking up the handset, the button  or buttons P1-P5 if properly programmed.

Button  connect you with the last calling external door station, whilst buttons P1÷P5 connect you with the door stations which address have been previously programmed in the buttons.

Control power ON ends after about 30 seconds, but it is interrupted if in the system another control power ON or a call is made.

If the user picks up the handset during a control power ON phase a connection with the external door station is automatically set.

Make or receive a call from another user

When the system is in stand by mode it would be possible call another user. To execute this operation it is necessary to have properly programmed the buttons P1÷P5 with the address of the user you want to call (max 5).



INTERNAL STATIONS

To make the call it is necessary to pick up the handset, verify the presence of the tone of system ready and press the button corresponding to the user you want to call, a calling tone is heard whilst the monitor of the called user will sound without powering itself ON. If the called user lifts the handset within 30 seconds a connection will be set for about 90 seconds, otherwise the system returns in stand by mode. Any call from the external door station will interrupt the internal call.

Make or receive an intercommunicating call.

When the system is in stand by mode it would be possible call another device installed in the same apartment (max 6). To execute this operation it is necessary to have properly programmed the buttons P1÷P5.

To make the call it is necessary to pick up the handset, verify for the presence of the system ready tone and press the button corresponding to the device you want to call. On the handset a calling tone is heard whilst the called device will sound without powering itself ON; calling sound will be different from that generated for a call from an external door station. If the called device answers within 30 seconds a connection will be set for about 90 seconds, otherwise the system returns in stand by mode.

Any call from the external door station will interrupt the intercommunicating call.

Supplementary Functions

Floor call

A floor call will generate a different sound on the monitor ant it does no power it ON. Floor call will only advise you that someone is calling from the door of your apartment. This function is enabled either with the system free or with the system busy.

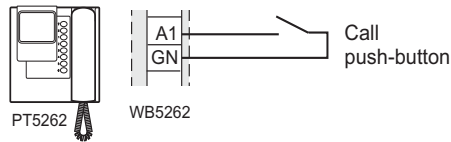

Local power supply

In case of lack in monitor powering, due to an underdimensioned cabling of the system, it would be possible to power the monitor locally using the terminals A+ and A- present on the wall bracket WB5262.

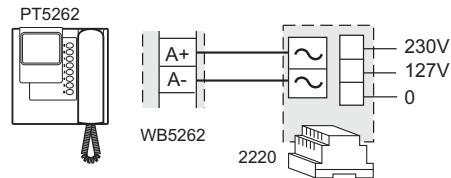

Note. Move the jumper **J2**, present on the wall bracket **WB5262** from the position **1-2** to the position **2-3**.

Call repeater

If you connect the devices according to the diagram reported below it would be possible to repeat the calling sound of the monitor in other rooms of your apartment.

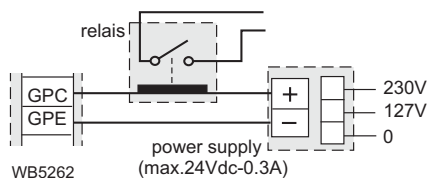

Tone table

Tone of recognized pressure of a button. It is activated to indicate the pressure of one of the buttons P1÷P5 during the programming phase.



Programming tone. It is activated to indicate the system is waiting to be programmed.



Acknowledge tone. It is activated to confirm the correct operation of the door lock release and during the programming phase to indicate a valid operation.



Tone of system ready. Activated for 30 seconds if the system is free



Calling tone. It is activated during a call to another user or during an intercommunicating call (active for 30 seconds or until the called user answers).



Dissuasion tone. It is activated when a nonexistent device is call or when a device is not available.



End conversation tone. It is activated 10 seconds before the conversation time ends.



Calling table

Call from external door unit – from other user



Intercommunicating call.



Floor call



Note. All the acoustic signalling, with the exception, of the system ready and calling tone last after about 2 seconds.



Module frames complete with back box

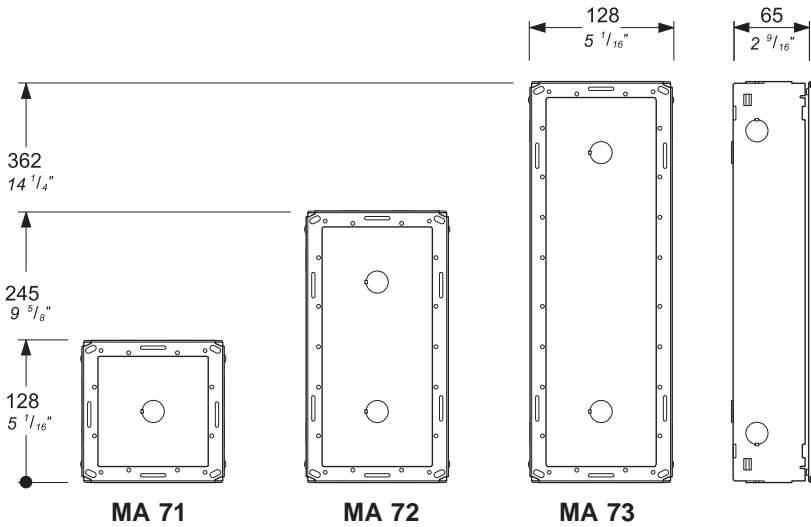

Stainless steel anti-vandalism push-button panels especially studied to withstand burglary, penetration of solids and water jets (IP 45 protection degree against the penetration of external solids and water; IK09 against shocks).

The Matrix push-button panels include back boxes, rain shelters, module frames, die-cast aluminium decorative frames, button modules, and video modules with built-in speaker unit.

The push-button elements have been developed to allow both for horizontal and vertical configuration.

Front frames

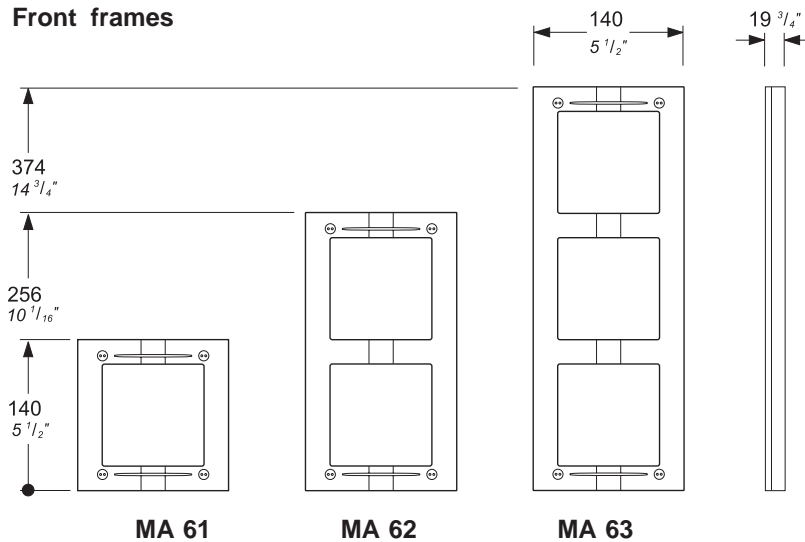

Audio-video module

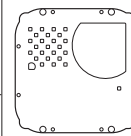

VD2120MA

Audio-video module without call buttons with B/W camera and door speaker integrated.

(for specifications see page 7)

Digital modules

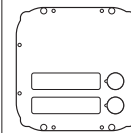

CD2132MA

Digitizer module with 2 call buttons (for specifications see page 12).

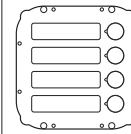

CD2134MA

Digitizer module with 4 call buttons (for specifications see page 12).

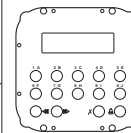

TD2100MA.

Digital door station (for specifications see page 7).

Rain shelters with module frames

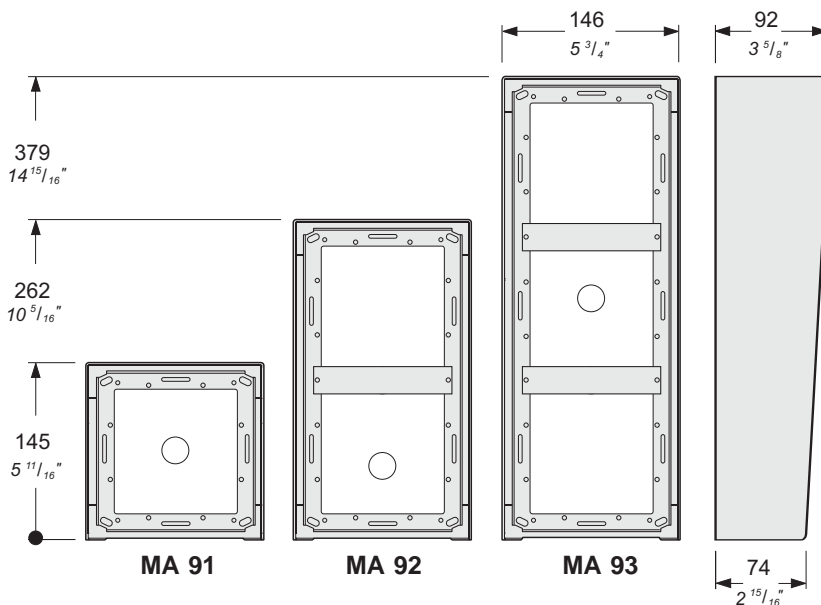

Blank and button modules

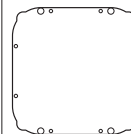

MA 20.

Blank module in stainless steel.

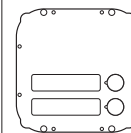

MA 22S.

Module with 2 call buttons and encoding board (for specifications see page 16)

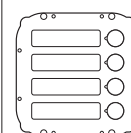

MA 24S.

Module with 4 call buttons and encoding board (for specifications see page 16)



AUDIO-VIDEO MODULE

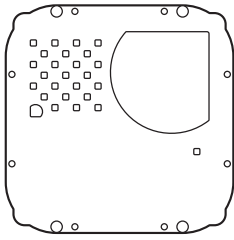

- VD2120MA.** Modules complete with:
- CCD camera with autoiris, fixed 3.6mm lens and 6 infrared LED's
 - amplified speaker unit with reception volume and anti-feedback adjustments
 - steel front plate with breakproof transparent screen
 - horizontal and vertical adjustments
 - red operation LED
 - connection to the digital encoding modules (CD2132MA and CD2134MA) and digital door station (TD2100MA) through the cable complete with connectors supplied together with the items listed here above.

Technical data

Power supply	13Vac±1 - 0.35A
Minimum illumination	2 Lux
Illumination system	6 infrared Led's
Sensor	CCD 1/4" B/W
Number of pixels	291,000
Lens	3.6mm; F5
Focus	0.1m ÷ ∞
Autoiris	electronic
Horizontal/vertical adjustment	±15°
Operating temperature	-10°÷+40°C
Max. permissible humidity	80%RH

Adjustments

You can manually change the camera framing by unloosening and adjusting the horizontal and vertical screws in the desired direction.

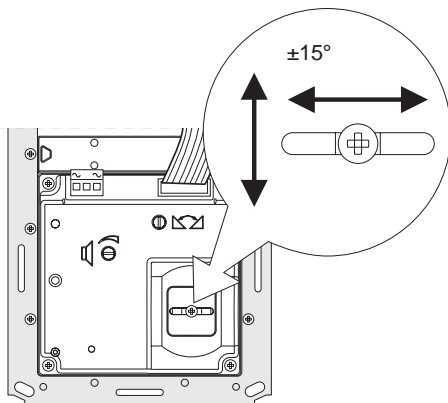

Volume adjustment

To increase the volume from the amplifier, turn the trimmer "↻" in a clockwise direction.

Anti-feedback adjustment

In case of "feedback" (Larsen effect) in the external unit it is necessary to operate as follow:
 - make the call from the door station and lift the handset of the called user;
 - adjust the trimmer "↻" until the whistling stops (Larsen effect).

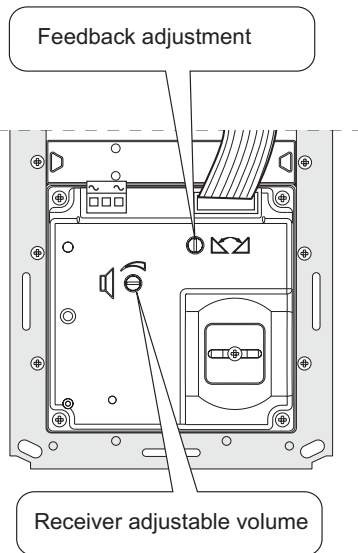

DIGITAL PUSH-BUTTON PANEL

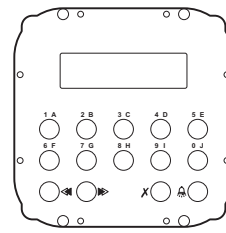

TD2100MA. Matrix series anti-vandalism steel push-button panel with 14 steel buttons and alphanumerical LCD. Used to dial and send calls over DUO digital line.

Technical features

Power supply	from audio/video module
Door-opening time	3/6 sec.
LCD	2 lines x 16 characters
Number of calls (hypothetical)	250
Memory	250 names
Dimensions	1 module
Operating temperature	0°÷+40°C
Maximum humidity acceptable	90% RH

Terminals

- LP/LP** audio-data-video to and from internal users
- P1/P1** direct call button inputs
- EC** positive signal for exchanger
- EM** negative signal for exchanger
- S1/S2** door opening contacts

Connection terminal boards

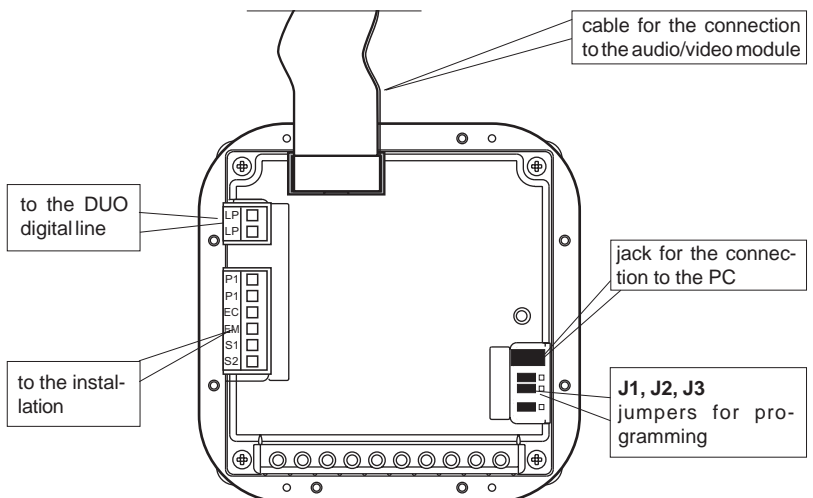

PROGRAMMING

Before programming you must:

- Move the jumper **J1** on the back of the push-button panel from **A** to **B**; the display shows "Programming / type: ""
- Dial the programming code (see table) and press to confirm.
- After you programme each single code, bring the jumper **J1** back to **A**.
- To exit and access the 2-digit programming codes you must move the jumper **J1**.

Positions of jumper J1

A = operation mode

B = programming mode

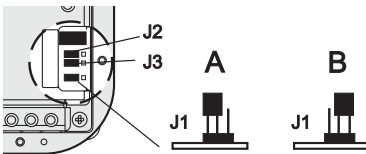

Table of programming codes

00	Entry of codes for door lock / address P1 / address PE
01	Entry-modification-deletion of names
02	Language selection
03	System programming
04	Entry of display initial text
05	Loading names from PC
06	Ordering names

Entry of codes for door lock / address P1 / address PE (code 00)

Enter the code **00** to access the "entry of door lock codes" mode. The display shows "PASSWORD 0 / ""

- Dial the first opening code on the keypad, for example 7890; the display shows "PASSWORD 0 / 7890".
- Press ; the display shows "PASSWORD 1 / ""
- Dial the second opening code on the keypad, for example 1234; the display shows "PASSWORD 1 / 1234".
- Press ; the display shows "PASSWORD 2 / ""
- Repeat the operation to enter a maximum of 16 codes. When you press to confirm the last code (PASSWORD 15) you enter the "entry of address P1 code" mode automatically. You can memorise the number of the internal station that can be called directly by pushing a button connected between terminals **P1 / P1**.
- Press ; the display shows "P1 / 0100".
- Press **X** to delete the code shown on the display and enter the number of the internal station you want to enable for the direct call

function. The internal stations can be coded with numbers from 1 to 200.

- Press to confirm and go to the "entry of address PE code"; the display shows "PE / 0231 ". You can enter the code for the external station address. The push-button panels can be coded with numbers from 231 to 250.
- Dial the code and press to confirm. You go back to the "entry of door lock codes" mode. The display shows the PASSWORD 0 code (PASSWORD 0 / internal station)".
- To exit programming bring the jumper **J1** back to the original position (from B to A).

Note. To delete the password and the address associated with P1 and PE press **X** and then press again.

Entry / modification / deletion of names (code 01)

You can enter 32 characters, of which 28 characters for the name and the last 4 characters on bottom right for the internal station number. When searching for characters, the display shows upper-case letters, low-case letters, numbers, characters . <> and space in a sequence.

Enter the names from top down and from left to right. You must enter a number in the last space on bottom right to save the name (see "deleting a name"). The push-button panel reorders the list in alphabetical order every time you enter and confirm a name.

Function of buttons

- Hold this button pressed to scroll the list of existing names
- X** Hold this button pressed to move the cursor to the name characters
- Hold this button pressed to scroll down the list of characters
- Hold this button pressed to scroll up the list of characters

Entry of names

- Move the jumper **J1** from **A** to **B**.
- Enter the code **01**; the display shows the first name. The display is empty if no codes are programmed.
- Press or to select the character for the first cell; press **X** to go to the second cell; press or to select the character for the second cell; continue until you have entered the complete name with code. Press **X** after you have entered the number in the last cell on bottom right; the display shows "STORE USER / YES < > NO"; press to confirm; press to modify the name.
- If confirmed, the display shows the second name. The display is empty if no names are programmed.

- Once you have confirmed the last name, bring the jumper back to the original position (from **B** to **A**). The display shows "waiting" and an automatic status bar. Normal operation is restored after a few seconds and the display shows the initial text (see "Operation").

Notes. Once you have entered 250 names the display shows "waiting" and an automatic status bar. After a few seconds the display shows "Programming / type: "" and you can continue with programming.

You can enter 2 or more names with the same call number (i.e. different family names in the same apartment).

Modification of names

- Press to search for the name you want to modify; (hold the button pressed for quick searching).
- Press **X** to go to the character you want to modify.
- Select the character with (forward) (backward).
- Repeat the operation until you have completed the name modification.
- Once you have completed the modification, hold **X** pressed until the display shows "STORE USER / YES < > NO" Press to confirm or to modify the name again. Enter a space to delete a letter.

Addition of 1 or more names to the list

To add a new name to the existing list press to scroll the list; the display is empty after the last name. To enter a new name follow the operations described in "Entry of names". If confirmed, the name is placed in the list in alphabetical order.

Deletion of names

- Press to search for the name you want to delete; (hold the button pressed for quick searching).
- Press **X** to go to the last cell (bottom right); enter a space to delete the existing number.
- Press **X** again; the display shows "DELETE USER / YES < > NO" Press to confirm or to go back to the name. The next name is displayed after you have deleted the name.

Language selection (code 02)

You can choose the language from 6 different options (Italian, English, French, German, Spanish and Portuguese) in operation mode.

- Move the jumper **J1** from **A** to **B**.
- Enter the code **02**; the display shows "Italiano" in case of first programming or the programmed language.



- Press **▶** or **◀** to select the language.
- Press **🔔** to confirm; the display shows "Programming / type: ".

System programming (code 03)

You can change or activate the functions of the push-button panel (see table).

- Enter the code **03**; the display shows "bit 0 = 0/0 <> 1" in case of first programming or "bit 0 = 1/0 <> 1" if changed in the previous programming.
- Press **▶** to select 1 or **◀** to select 0.
- Press **🔔** to confirm and go to the next code (see code table with descriptions).
- Once you have confirmed the value of the last code (bit 7), the display shows "Programming / type: " and you can continue with programming.

Personalisation of display initial text (code 04)

You can modify the text shown on the display during normal operation or idle state. You must programme bit 5 to display the text (see "system programming").

- Enter the code **04**; the display shows "DUO System", in case of first programming, or the text you want to replace.
- For information on how to enter the characters see "entry of names".
- Press **🔔** to confirm; the display shows "Programming / type: " and you can continue with programming.

Loading names from PC

You can load names directly from your PC.

- Load the names on the PC using a dedicated software application (software supplied on demand).
- Turn off the push-button panel and the PC.

- Connect the PC serial port to the stereo jack on the back of the push-button panel with a cable as shown in the figure.
 - Move the jumpers **J2** and **J3** on the back of the push-button panel from **A** to **B** (also the jumper **J1** must be on **B**).
 - Turn on the PC and then the push-button.
 - Enter the code **05**; the display shows "TD2100MA > PC / in progress 0".
 - Download the names from the PC within 15 seconds; the display shows "TD2100MA < -> PC / in progress 1", "TD2100MA < -> PC / in progress 2" and then the downloaded names.
- At the end of download the push-button deletes the existing names. The first line of the display shows "waiting" and the second line shows a status bar to show the progress of the deletion operation. At the end the display shows "Programming / type: ".
- Turn off the push-button panel and then the PC.
 - Disconnect the cable from the PC and the push-button panel.
 - Bring the jumpers **J2** and **J3** back to **A**; bring the jumper **J1** back to **A** if you have completed programming, otherwise continue with programming.

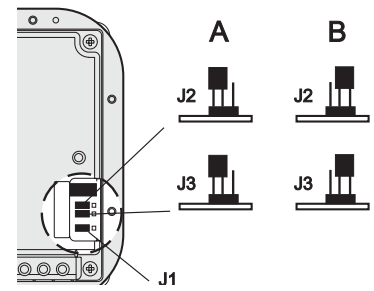

Ordering names

You can list the names in alphabetical order (from A to Z).

- Enter the code **06**; the first line of the display shows "waiting" and the second line shows a status bar; at the end of the operation the push-button panel returns automatically to the programming mode (the display shows "Programming / type: ").

Return to operation mode

Once you have completed programming, bring the jumper **J1** back to **A**; the display shows "ACI FARFISA / press <>" or the text you have entered during programming (see "Personalisation of display initial text").

PC serial port Stereo jack Ø = 2.5mm

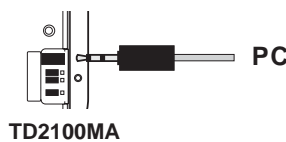
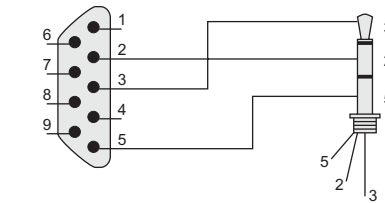

Table of system programming codes

Programming code \	Function description	Value entered with buttons	
		◀ = 0	▶ = 1
bit 0	door lock activation time	3 sec.	6 sec.
bit 1	activation upon call from internal station (1)	NO	YES
bit 2	door lock activation with X (2)	NO	YES
bit 3	deactivation of tone generator on the external door station	NO	YES
bit 4	activation of personalised initial screen (3)	NO	YES
bit 5	deactivation of ACI FARFISA and activation of personalised text	NO	YES
bit 6	reserved; do not program	-	-
bit 7	reserved; do not program	-	-

- (1) This function allows the internal stations to press the **👁** button, start a conversation with the external station (in case of more external stations in parallel the connection is established with the last calling door station) and activate the door lock by pressing the button **🔑**.
- (2) This functions allows for quicker door lock activation by pressing **X** rather than dialling the code 00+**🔔**. For example: press **X** + password + **🔔**.
- (3) You can alternate "ACI FARFISA" with the personalised text (see "personalisation of display initial text").



OPERATION

Check that all connections are correct. Connect the power supply unit to the mains; the displays shows the software version of the push-button panel for 3 seconds followed by "ACI/FARFISA /press <> (<> in alternate mode).

Dial the user number, check that the number is correct on the display "dialling /----" and press to make the call. The tone and the text "calling / ----" confirm that the call has been made.

In case of error press **X** (only before sending the call) and dial the correct to number.

If the number exists you hear the confirmation tone and the display shows "calling /----".

You can select the internal station from the names in the list. Press or to search for the internal station and press to send the call. The called station will ring only once; but, if in this phase, press another time the station rings again. If press **X** the call is terminated and the system is ready for a new call.

The called user picks up the handset enables the conversation with the external station for 60 seconds. The display shows "connection /---". The text on the display starts flashing 10 seconds before conversation ends. To continue conversation for additional 60 seconds press again.

Press the button to release the door lock. Door lock activation time is 3 seconds (or 6 seconds).

Replace the handset to or press **X** on the door station to restore the idle state.

Numbers that are not sent or deleted go off after 25 seconds.

In installations with **2 or more digital push-button panels**, when a call is made from one push-button panel, the other push-button panels are deactivated and their display shows "busy /".

Wait until the line is free to make the call.

Door lock opening

The door lock can be opened from the push-button panel, including in "busy" mode, by dialling one of the 16 4-digit codes you have entered.

Door lock activation

- Dial **00**
- Press ; the display shows "Password/ ■■ ■■"
- Dial the personal access code within 10 seconds; each digit is visualised with * instead of ■.
- Press to release the door lock; you hear the confirmation tone and the push-button panel returns to the current system operation mode (free or busy).

Composition digital push-button panel

Audio-video composition

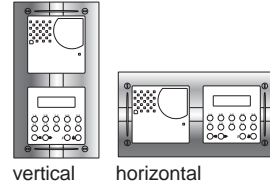

- Composed of:
- 1 TD2100MA
 - 1 VD2120MA
 - 1 MA62
 - 1 MA72

"Dialling"

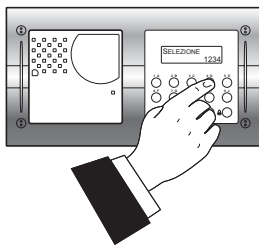

or "Search"

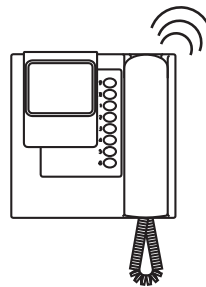
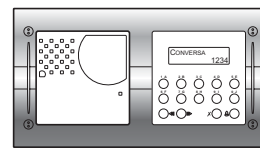
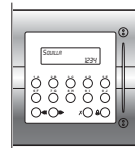
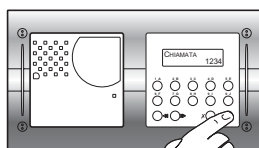
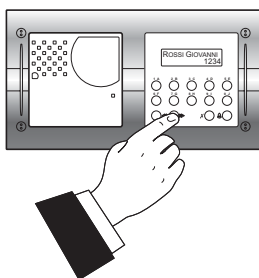

DIGITAL ENCODER

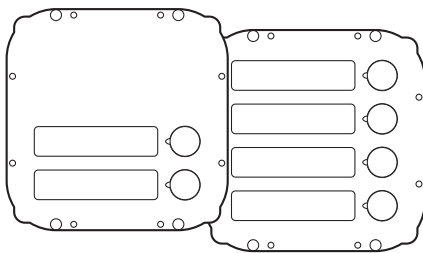

CD2132MA. Encoding module with front plate and two stainless steel buttons. Complete with name-holders with transparent screen green color backlit breaking resistant and with connection cable to the next module. Used to send calls over DUO digital line.

CD2134MA. With 4 call buttons.

Technical features

Power supply from audio/video module	
Door-opening time	3 / 6 sec.
Number of calls (hypothetical)	128
Dimensions	1 module
Operating temperature	0° ÷ +40°C
Maximum humidity acceptable	90% RH

Terminals

LP/LP	audio-data-video to and from internal users
EC	positive signal for exchanger
EM	negative signal for exchanger
S1/S2	door opening contacts

PROGRAMMING

To program the device it is necessary:

- Move the jumper **J1** from **A** to **B** position; a programming tone will confirm the correct operation.

All the following operations are divided into two phases. The first is to set the programming code on the micro-switches **MS1** and **MS2**, the second is to enter the code by pressing the button **SW1**. An acknowledge tone will confirm a correct code; an error tone will indicate a wrong code, in this case it is necessary to set a correct code and enter it again.

In any moment it is possible to exit the programming phase by setting OFF all the micro-switches **MS1** and **MS2** and moving back the jumper **J1** from B to A position.

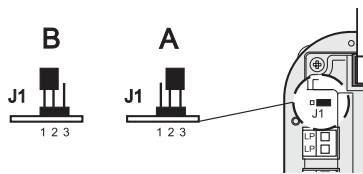

Position of jumper J1

- A = operating mode
- B = programming mode

Position of button SW1 and micro-switches MS1 and MS2

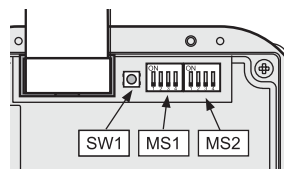

Connection terminal boards

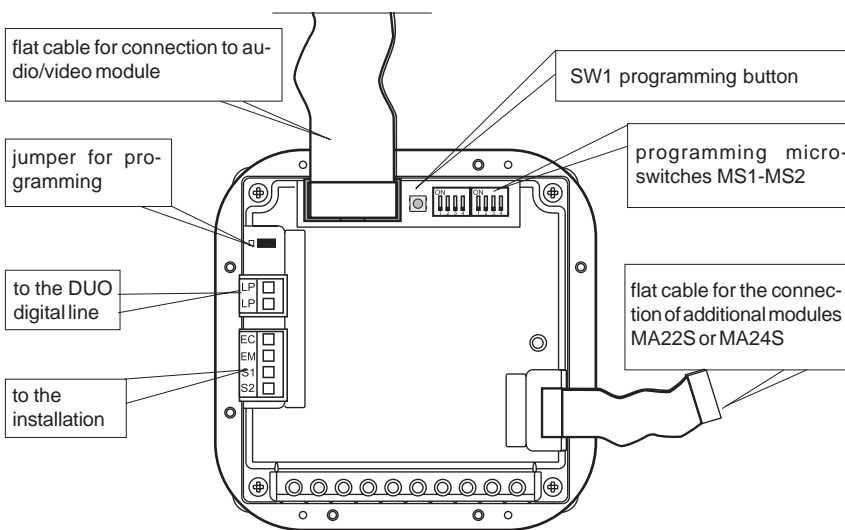

Programming codes entering

- Choose the desired programming code and set it on the micro-switches according to the table 1.
- Press the programming button **SW1**.

Table 1
Programming codes

	MS1	MS2
1A user address associated to the first button		
	1	A
2A user address associated to the last button		
	2	A
1B address of the external door station		
	1	B
2B system programming		
	2	B

Example: **MS1 MS2 SW1**



Entering the sequence above described, you will enter in the programming mode of associating the address to the first calling button of the module.

Programming mode of associating the address to the first calling button of the module (code 1A).

- Set the micro-switches of **MS1** and **MS2** according to the address, between 1 and 200, you want to associate to the first calling button of the module (see table 2).
- Press the programming button **SW1**.

Programming mode of associating the address to the last calling button of the module (code 2A)

- Set the micro-switches of **MS1** and **MS2** according to the address, between 1 and 200, you want to associate to the last calling button of the module (see table 2).
- Press the programming button **SW1**.

This programming is useful when the push button panel has more buttons than the connected users and to prevent the case when, by pressing an enabled button, the system gets busy along 30 seconds.

Programming mode of entering the address of the external door station (code 1B)

- Set the micro-switches of **MS1** and **MS2** according to the address, between 231 and 250, you want to give to the external door station.
- Press the programming button **SW1**.



Table 2
Cross-reference table between codes and microswitches position of MS1 and MS2.

	MS1	MS2		MS1	MS2		MS1	MS2		MS1	MS2		MS1	MS2
1			21			41			61			81		
2			22			42			62			82		
3			23			43			63			83		
4			24			44			64			84		
5			25			45			65			85		
6			26			46			66			86		
7			27			47			67			87		
8			28			48			68			88		
9			29			49			69			89		
10			30			50			70			90		
11			31			51			71			91		
12			32			52			72			92		
13			33			53			73			93		
14			34			54			74			94		
15			35			55			75			95		
16			36			56			76			96		
17			37			57			77			97		
18			38			58			78			98		
19			39			59			79			99		
20			40			60			80			100		



101	MS1 ON 1 2 3 4	MS2 ON 1 2 3 4	121	MS1 ON 1 2 3 4	MS2 ON 1 2 3 4	141	MS1 ON 1 2 3 4	MS2 ON 1 2 3 4	161	MS1 ON 1 2 3 4	MS2 ON 1 2 3 4	181	MS1 ON 1 2 3 4	MS2 ON 1 2 3 4
102	ON 1 2 3 4	ON 1 2 3 4	122	ON 1 2 3 4	ON 1 2 3 4	142	ON 1 2 3 4	ON 1 2 3 4	162	ON 1 2 3 4	ON 1 2 3 4	182	ON 1 2 3 4	ON 1 2 3 4
103	ON 1 2 3 4	ON 1 2 3 4	123	ON 1 2 3 4	ON 1 2 3 4	143	ON 1 2 3 4	ON 1 2 3 4	163	ON 1 2 3 4	ON 1 2 3 4	183	ON 1 2 3 4	ON 1 2 3 4
104	ON 1 2 3 4	ON 1 2 3 4	124	ON 1 2 3 4	ON 1 2 3 4	144	ON 1 2 3 4	ON 1 2 3 4	164	ON 1 2 3 4	ON 1 2 3 4	184	ON 1 2 3 4	ON 1 2 3 4
105	ON 1 2 3 4	ON 1 2 3 4	125	ON 1 2 3 4	ON 1 2 3 4	145	ON 1 2 3 4	ON 1 2 3 4	165	ON 1 2 3 4	ON 1 2 3 4	185	ON 1 2 3 4	ON 1 2 3 4
106	ON 1 2 3 4	ON 1 2 3 4	126	ON 1 2 3 4	ON 1 2 3 4	146	ON 1 2 3 4	ON 1 2 3 4	166	ON 1 2 3 4	ON 1 2 3 4	186	ON 1 2 3 4	ON 1 2 3 4
107	ON 1 2 3 4	ON 1 2 3 4	127	ON 1 2 3 4	ON 1 2 3 4	147	ON 1 2 3 4	ON 1 2 3 4	167	ON 1 2 3 4	ON 1 2 3 4	187	ON 1 2 3 4	ON 1 2 3 4
108	ON 1 2 3 4	ON 1 2 3 4	128	ON 1 2 3 4	ON 1 2 3 4	148	ON 1 2 3 4	ON 1 2 3 4	168	ON 1 2 3 4	ON 1 2 3 4	188	ON 1 2 3 4	ON 1 2 3 4
109	ON 1 2 3 4	ON 1 2 3 4	129	ON 1 2 3 4	ON 1 2 3 4	149	ON 1 2 3 4	ON 1 2 3 4	169	ON 1 2 3 4	ON 1 2 3 4	189	ON 1 2 3 4	ON 1 2 3 4
110	ON 1 2 3 4	ON 1 2 3 4	130	ON 1 2 3 4	ON 1 2 3 4	150	ON 1 2 3 4	ON 1 2 3 4	170	ON 1 2 3 4	ON 1 2 3 4	190	ON 1 2 3 4	ON 1 2 3 4
111	ON 1 2 3 4	ON 1 2 3 4	131	ON 1 2 3 4	ON 1 2 3 4	151	ON 1 2 3 4	ON 1 2 3 4	171	ON 1 2 3 4	ON 1 2 3 4	191	ON 1 2 3 4	ON 1 2 3 4
112	ON 1 2 3 4	ON 1 2 3 4	132	ON 1 2 3 4	ON 1 2 3 4	152	ON 1 2 3 4	ON 1 2 3 4	172	ON 1 2 3 4	ON 1 2 3 4	192	ON 1 2 3 4	ON 1 2 3 4
113	ON 1 2 3 4	ON 1 2 3 4	133	ON 1 2 3 4	ON 1 2 3 4	153	ON 1 2 3 4	ON 1 2 3 4	173	ON 1 2 3 4	ON 1 2 3 4	193	ON 1 2 3 4	ON 1 2 3 4
114	ON 1 2 3 4	ON 1 2 3 4	134	ON 1 2 3 4	ON 1 2 3 4	154	ON 1 2 3 4	ON 1 2 3 4	174	ON 1 2 3 4	ON 1 2 3 4	194	ON 1 2 3 4	ON 1 2 3 4
115	ON 1 2 3 4	ON 1 2 3 4	135	ON 1 2 3 4	ON 1 2 3 4	155	ON 1 2 3 4	ON 1 2 3 4	175	ON 1 2 3 4	ON 1 2 3 4	195	ON 1 2 3 4	ON 1 2 3 4
116	ON 1 2 3 4	ON 1 2 3 4	136	ON 1 2 3 4	ON 1 2 3 4	156	ON 1 2 3 4	ON 1 2 3 4	176	ON 1 2 3 4	ON 1 2 3 4	196	ON 1 2 3 4	ON 1 2 3 4
117	ON 1 2 3 4	ON 1 2 3 4	137	ON 1 2 3 4	ON 1 2 3 4	157	ON 1 2 3 4	ON 1 2 3 4	177	ON 1 2 3 4	ON 1 2 3 4	197	ON 1 2 3 4	ON 1 2 3 4
118	ON 1 2 3 4	ON 1 2 3 4	138	ON 1 2 3 4	ON 1 2 3 4	158	ON 1 2 3 4	ON 1 2 3 4	178	ON 1 2 3 4	ON 1 2 3 4	198	ON 1 2 3 4	ON 1 2 3 4
119	ON 1 2 3 4	ON 1 2 3 4	139	ON 1 2 3 4	ON 1 2 3 4	159	ON 1 2 3 4	ON 1 2 3 4	179	ON 1 2 3 4	ON 1 2 3 4	199	ON 1 2 3 4	ON 1 2 3 4
120	ON 1 2 3 4	ON 1 2 3 4	140	ON 1 2 3 4	ON 1 2 3 4	160	ON 1 2 3 4	ON 1 2 3 4	180	ON 1 2 3 4	ON 1 2 3 4	200	ON 1 2 3 4	ON 1 2 3 4



201		211		221		231		241	
202		212		222		232		242	
203		213		223		233		243	
204		214		224		234		244	
205		215		225		235		245	
206		216		226		236		246	
207		217		227		237		247	
208		218		228		238		248	
209		219		229		239		249	
210		220		230		240		250	



Programming operating mode of the system (code 2B)

- Set the micro-switches of **MS1** and **MS2** according to the mode you want the system to operate (see table 3).
- Press the programming button **SW1**.

Exit the programming phase

To exit the programming phase it is necessary to set OFF all the micro-switches **MS1** and **MS2** and moving back the jumper **J1** from **B** to **A** position.

Table 3 Operating mode of the system (code 2B)				
Micro-switches position of MS1			Operating modes	
			OFF	ON
	1	3 sec.	6 sec.	door lock activation time
	2	NO	YES	activation upon call from internal station *
	3	-	-	reserved; do not program
	4	NO	YES	deactivation of tone generator on the external door station *

* This function allows the internal stations to press the button, start a conversation with the external station (in case of more external stations in parallel the connection is established with the last calling door station) and activate the door lock by pressing the button .

Tone table

End of conversation



Indicates an error during the programming phase or that the conversation time is near to expire.

Busy



Indicates that the user is busy or not existing or that the line is busy.

Dissuasion



Indicates that the push-buttons were wrongly programmed or not used in the system.

Programming



Indicates that the programming mode was accessed.

Acknowledge



Indicates that the programming was executed correctly or that a call is in progress.



PUSH-BUTTON MODULES WITH INTEGRATED ENCODING BOARD

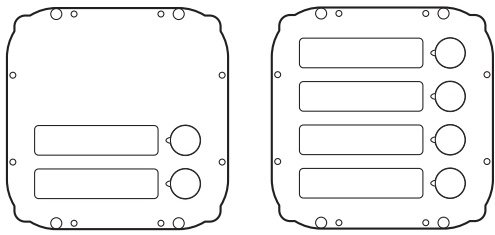

Terminals

- A** AC or DC power supply input for name-plate Led (13Vac or dc)
- AC power supply or ground input for name-plate Led

The button modules with integrated encoding board, thanks to the connection to the encoder module CD2132MA or CD2134MA, allow the calls in DUO systems.

MA 22S.

Module with antivandal stainless steel front plate and two call buttons. Complete with name holders with transparent screen green colour backlit resistant to breaking and connection cable to the next module.

MA 24S.

Same as the previous, but with 4 call buttons.

Installation and connections

- Connect the digital encoder to the connector JP1 of the first MA22S or MA24S module using the flat cable supplied with the digital encoder.
- Connect the connector JP2 of the first MA22S or MA24S module to the connector JP1 of the second MA22S or MA24S module using the flat cable supplied with the product.
- Connect in the same way all the other MA22S or MA24S modules.
- Remove the flat cable from the last MA22S or MA24S module because it is not used.

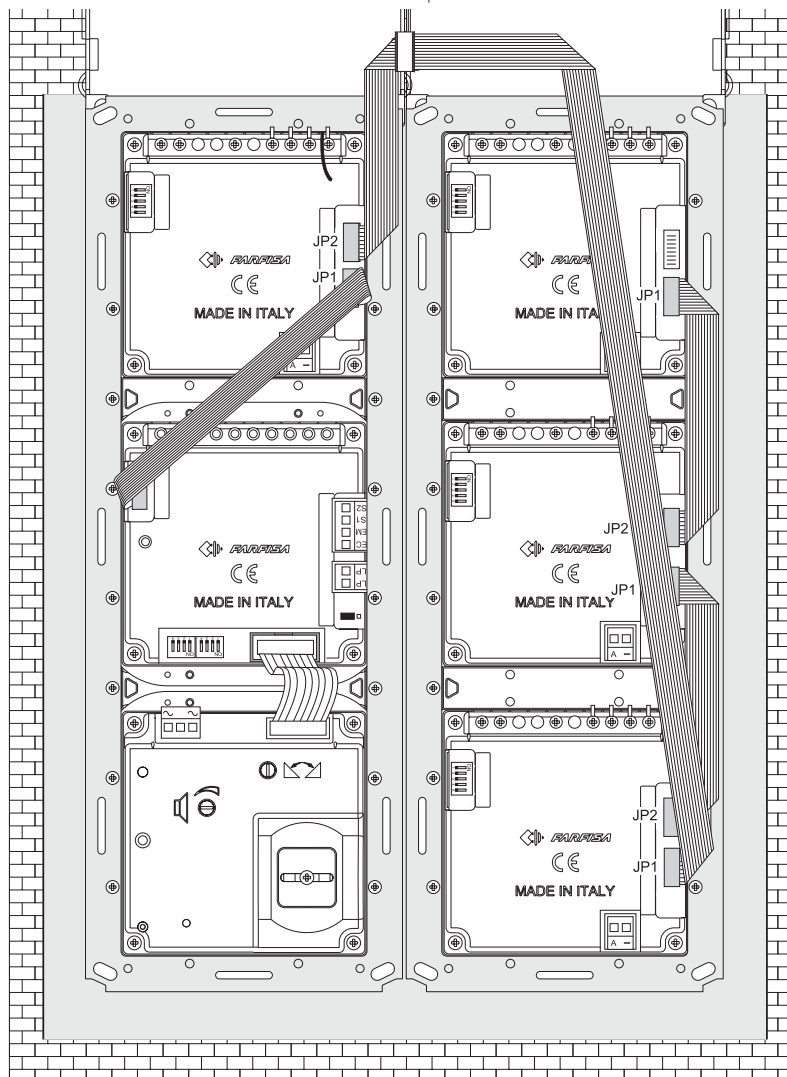

Push-button numerical interval

Microswitch position

0 ÷ 3

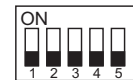

4 ÷ 7



8 ÷ 11



12 ÷ 15



16 ÷ 19



20 ÷ 23



24 ÷ 27



28 ÷ 31



32 ÷ 35

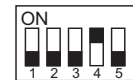

36 ÷ 39



40 ÷ 43



44 ÷ 47



48 ÷ 51

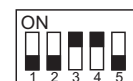

52 ÷ 55



56 ÷ 59



60 ÷ 63



Programming

The micro-switches, present on the back of the MA22S or MA24S, allow the digital encoder to recognize the code of the connected buttons, consequently they must be programmed properly.

The programmed codes must correspond to the addresses of the internal users. In case of installations with secondary door stations (multiple entrances), attention must be paid also to the numerical interval recognized by the digital exchanger.

The code set on the micro-switches is the address called by the first button of the module starting from the top. The other buttons will call increasing addresses (e.g. if the code set on the micro-switches is 36 the buttons, starting from the top of an MA24S module, will call respectively the users 36, 37, 38 and 39.

Note 1. Great attention must be paid when the code 0 (numerical interval 0-3) is set on the micro-switches because in this case the first button, starting from the top of the module MA22S or MA24S will call no users. This is because the digital system does not recognize the address **0 (zero)**.

Note 2. In case of the module MA22S with 2 buttons, the addresses associated to the 3rd and 4th button will be lost.

OPERATION

Check that all the connections are correct. Connect the power supply unit to the mains.

To make a call press the button corresponding to the desired user. Call is confirmed by an acknowledge tone, if the communication line is available, or denied by a busy tone if the communication line is not available (see tone table).

Called equipment rings only once, but if in this phase the same calling button on the external station is pressed again the equipment will ring another time.

The called user picks up the handset enables the conversation with the external station for 90 seconds.

A tone will advise the user 10 seconds before the conversation ends. To continue conversation for additional 90 seconds on the external station the calling button must be pressed again.

Press the  button to release the door lock. Door lock activation time is 3 seconds (or 6 seconds according to the system programming).

Replace the handset to end the conversation and restore the idle state.

In installations with **2 or more external door stations** when a call is made from one push-panel, the other push-buttons panel are deactivated with a busy indication(red LED flashing on the audio or audio/video module). Wait until the line is free to make a call.

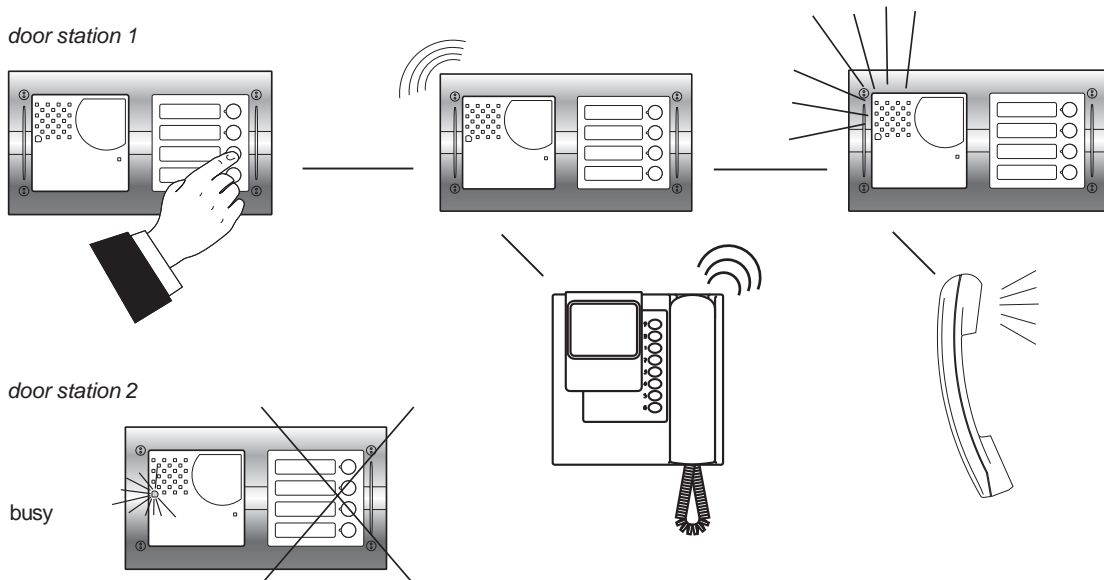

Examples of installations in videointercom systems

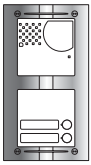

2 call buttons

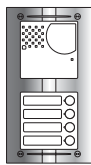

4 call buttons

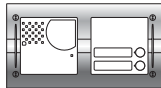

2 call buttons

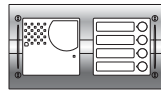

4 call buttons

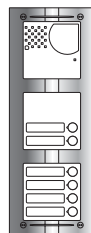

6 call buttons

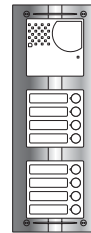

8 call buttons

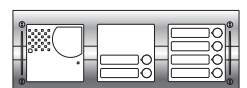

6 call buttons

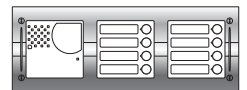

8 call buttons

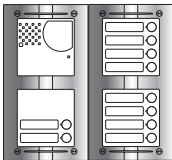

10 call buttons

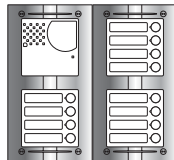

12 call buttons

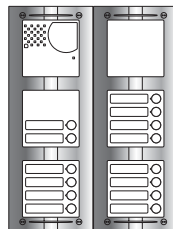

14 call buttons

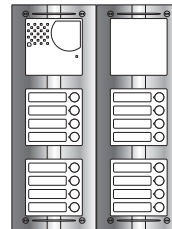

16 call buttons

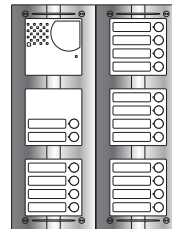

18 call buttons

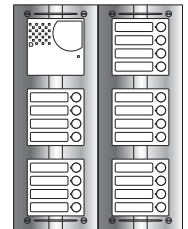

20 call buttons

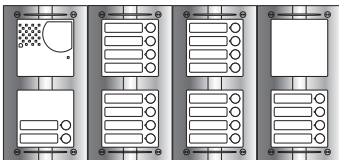

22 call buttons

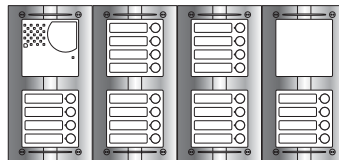

24 call buttons

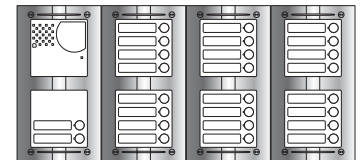

26 call buttons

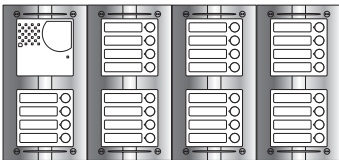

28 call buttons

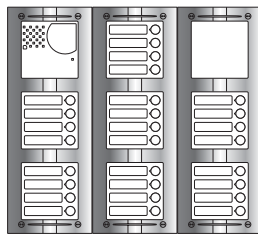

28 call buttons

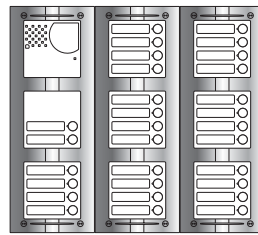

30 call buttons

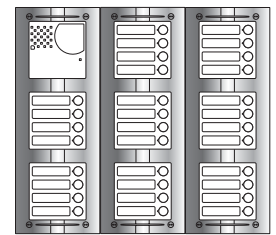

32 call buttons

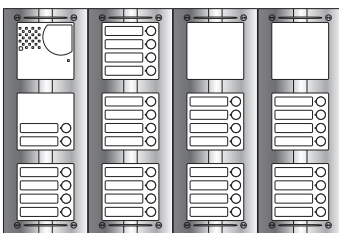

34 call buttons

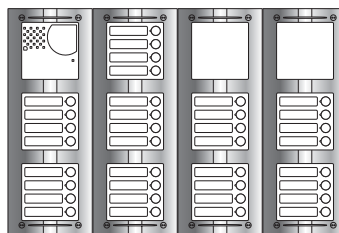

36 call buttons

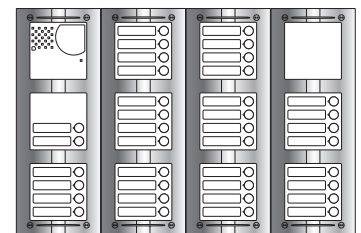

38 call buttons

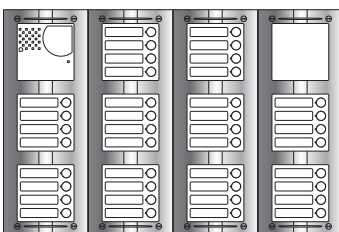

40 call buttons

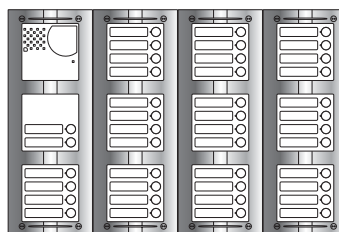

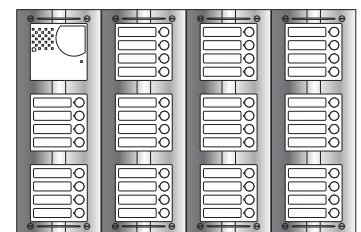

42 call buttons



44 call buttons

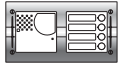

Composition board of push-button panels.

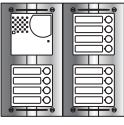
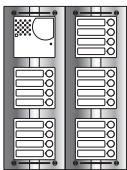
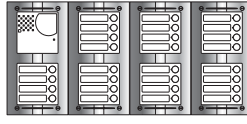
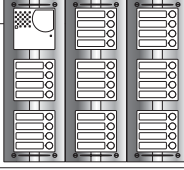
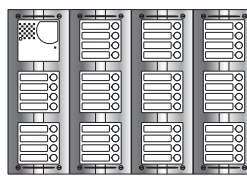
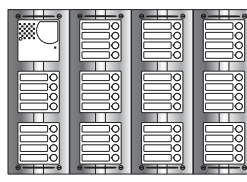
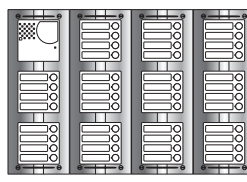
N° calls	Composition and dimensions	Encoder module	Camera and speaker mod.	Button module and blank module	Front frames	Back boxes and module frame	Rain shelters
1	 <p>140x256x19 (5 1/2" x 10 1/16" x 3/4")</p>	1 CD2132MA	1 VD2120MA	- -	1 MA62	1 MA72	1 MA92
2		1 CD2132MA	1 VD2120MA	- -	1 MA62	1 MA72	1 MA92
3		1 CD2134MA	1 VD2120MA	- -	1 MA62	1 MA72	1 MA92
4		1 CD2134MA	1 VD2120MA	- -	1 MA62	1 MA72	1 MA92
5	 <p>140x374x19 (5 1/2" x 14 3/4" x 3/4")</p>	1 CD2132MA	1 VD2120MA	1 MA24S -	1 MA63	1 MA73	1 MA93
6		1 CD2132MA	1 VD2120MA	1 MA24S -	1 MA63	1 MA73	1 MA93
7		1 CD2134MA	1 VD2120MA	1 MA24S -	1 MA63	1 MA73	1 MA93
8		1 CD2134MA	1 VD2120MA	1 MA24S -	1 MA63	1 MA73	1 MA93
9	 <p>280x256x19 (11" x 10 1/16" x 3/4")</p>	1 CD2132MA	1 VD2120MA	2 MA24S -	2 MA62	2 MA72	2 MA92
10		1 CD2132MA	1 VD2120MA	2 MA24S -	2 MA62	2 MA72	2 MA92
11		1 CD2134MA	1 VD2120MA	2 MA24S -	2 MA62	2 MA72	2 MA92
12		1 CD2134MA	1 VD2120MA	2 MA24S -	2 MA62	2 MA72	2 MA92
13	 <p>280x374x19 (11" x 14 3/4" x 3/4")</p>	1 CD2132MA	1 VD2120MA	3 MA24S 1 MA20	2 MA63	2 MA73	2 MA93
14		1 CD2132MA	1 VD2120MA	3 MA24S 1 MA20	2 MA63	2 MA73	2 MA93
15		1 CD2134MA	1 VD2120MA	3 MA24S 1 MA20	2 MA63	2 MA73	2 MA93
16		1 CD2134MA	1 VD2120MA	3 MA24S 1 MA20	2 MA63	2 MA73	2 MA93
17		1 CD2132MA	1 VD2120MA	4 MA24S -	2 MA63	2 MA73	2 MA93
18		1 CD2132MA	1 VD2120MA	4 MA24S -	2 MA63	2 MA73	2 MA93
19		1 CD2134MA	1 VD2120MA	4 MA24S -	2 MA63	2 MA73	2 MA93
20		1 CD2134MA	1 VD2120MA	4 MA24S -	2 MA63	2 MA73	2 MA93
21	 <p>560x256x19 (22 1/16" x 10 1/16" x 3/4")</p>	1 CD2132MA	1 VD2120MA	5 MA24S 1 MA20	4 MA62	4 MA72	4 MA92
22		1 CD2132MA	1 VD2120MA	5 MA24S 1 MA20	4 MA62	4 MA72	4 MA92
23		1 CD2134MA	1 VD2120MA	5 MA24S 1 MA20	4 MA62	4 MA72	4 MA92
24		1 CD2134MA	1 VD2120MA	5 MA24S 1 MA20	4 MA62	4 MA72	4 MA92
25	 <p>420x374x19 (16 9/16" x 14 3/4" x 3/4")</p>	1 CD2132MA	1 VD2120MA	6 MA24S -	4 MA62	4 MA72	4 MA92
26		1 CD2132MA	1 VD2120MA	6 MA24S -	4 MA62	4 MA72	4 MA92
27		1 CD2134MA	1 VD2120MA	6 MA24S -	4 MA62	4 MA72	4 MA92
28		1 CD2134MA	1 VD2120MA	6 MA24S -	4 MA62	4 MA72	4 MA92
29	 <p>560x374x19 (22 1/16" x 14 3/4" x 3/4")</p>	1 CD2132MA	1 VD2120MA	7 MA24S -	3 MA63	3 MA73	3 MA93
30		1 CD2132MA	1 VD2120MA	7 MA24S -	3 MA63	3 MA73	3 MA93
31		1 CD2134MA	1 VD2120MA	7 MA24S -	3 MA63	3 MA73	3 MA93
32		1 CD2134MA	1 VD2120MA	7 MA24S -	3 MA63	3 MA73	3 MA93
33	 <p>560x374x19 (22 1/16" x 14 3/4" x 3/4")</p>	1 CD2132MA	1 VD2120MA	8 MA24S 2 MA20	4 MA63	4 MA73	4 MA93
34		1 CD2132MA	1 VD2120MA	8 MA24S 2 MA20	4 MA63	4 MA73	4 MA93
35		1 CD2134MA	1 VD2120MA	8 MA24S 2 MA20	4 MA63	4 MA73	4 MA93
36		1 CD2134MA	1 VD2120MA	8 MA24S 2 MA20	4 MA63	4 MA73	4 MA93
37		1 CD2132MA	1 VD2120MA	9 MA24S 1 MA20	4 MA63	4 MA73	4 MA93
38		1 CD2132MA	1 VD2120MA	9 MA24S 1 MA20	4 MA63	4 MA73	4 MA93
39		1 CD2134MA	1 VD2120MA	9 MA24S 1 MA20	4 MA63	4 MA73	4 MA93
40		1 CD2134MA	1 VD2120MA	9 MA24S 1 MA20	4 MA63	4 MA73	4 MA93
41	 <p>560x374x19 (22 1/16" x 14 3/4" x 3/4")</p>	1 CD2132MA	1 VD2120MA	10 MA24S -	4 MA63	4 MA73	4 MA93
42		1 CD2132MA	1 VD2120MA	10 MA24S -	4 MA63	4 MA73	4 MA93
43		1 CD2134MA	1 VD2120MA	10 MA24S -	4 MA63	4 MA73	4 MA93
44		1 CD2134MA	1 VD2120MA	10 MA24S -	4 MA63	4 MA73	4 MA93



DOOR STATIONS

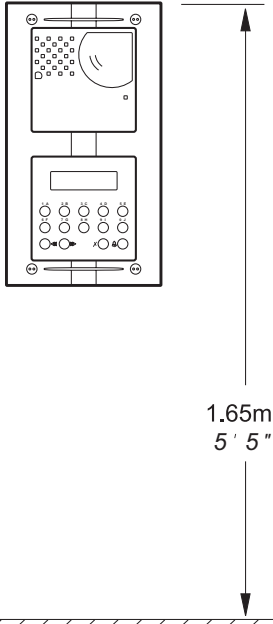

Place the push-button panel back box at a height of about 1.65m (5' 5") from the floor keeping the front edges flush-mounted and vertical to the finished plaster.

Position the camera in such a way that sunlight or other direct or reflected light sources with high intensity do not hit the camera lens.

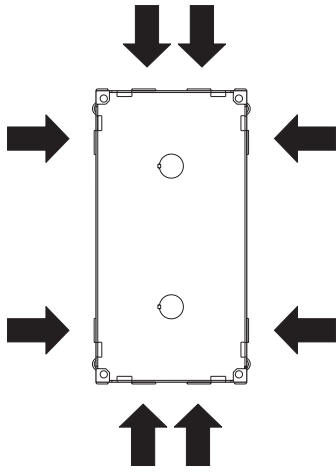

Openings for cables.

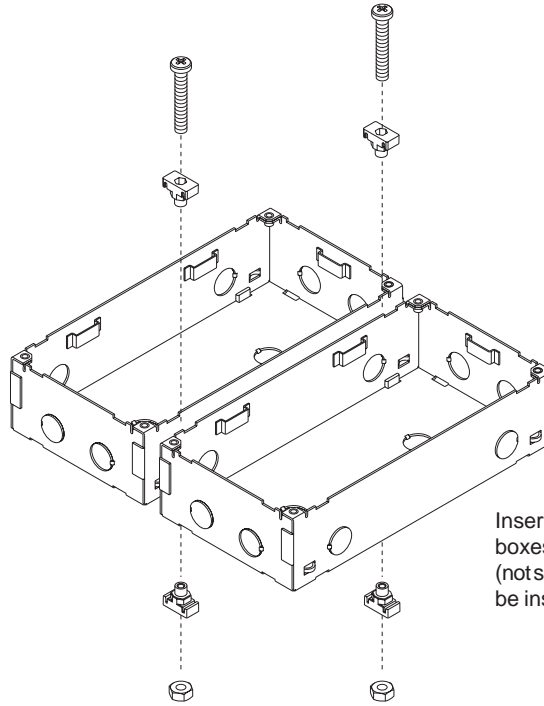

Insertion of spacers between back boxes. Spacers and cable bushing (not supplied with the products) must be inserted before brick work.

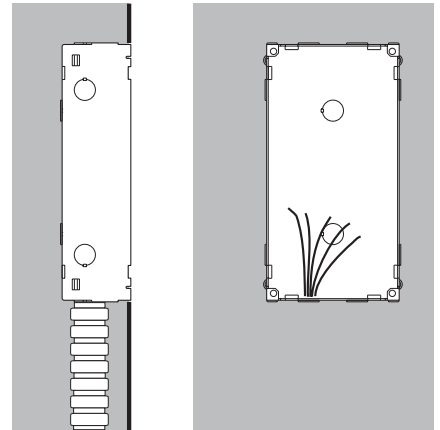

Flush mounting and cables placing.

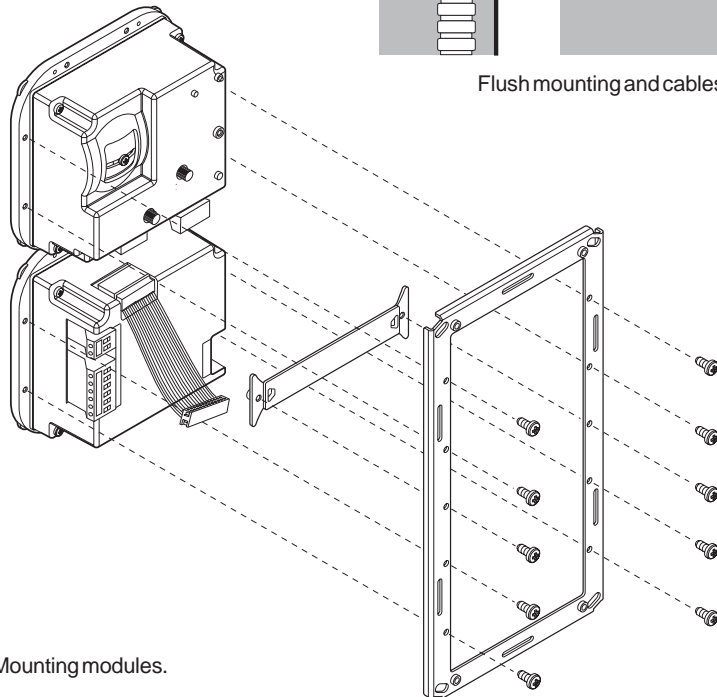

Mounting modules.



DOOR STATIONS

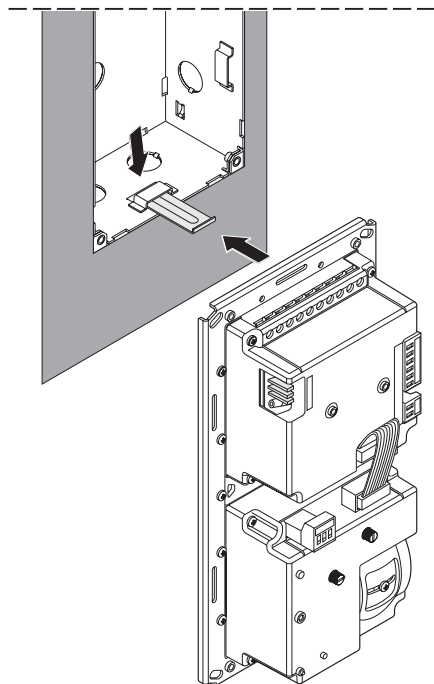

For easier connection to the electrical system, it is recommended to insert the metal plate supplied with the product in the back box opening, as shown in the figure. The plate is used to hook the frame with pre-assembled modules. Leave the plate in the box to reuse it for maintenance operations.

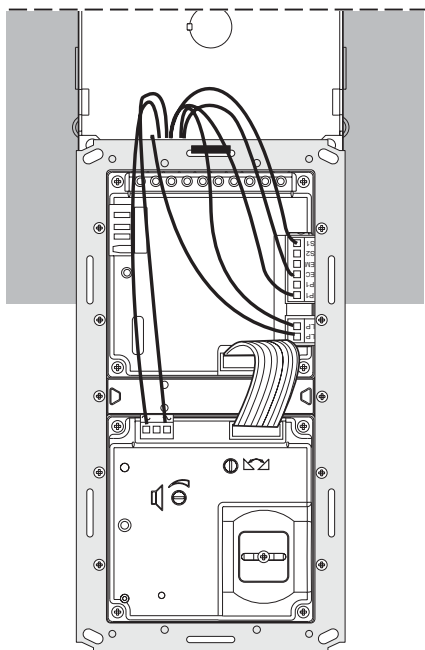

Connection of wires to module terminal boxes.

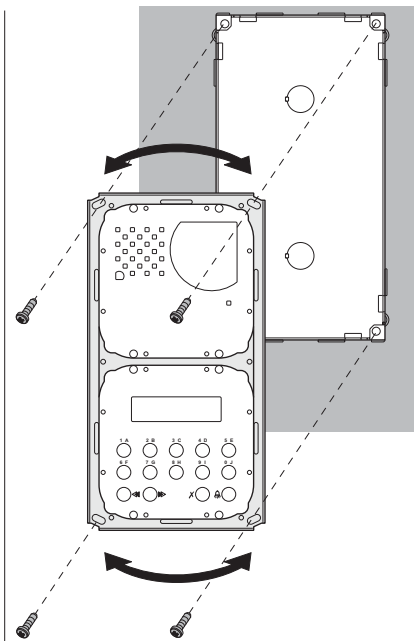

Fixing of frame to back box. Align the frame before tightening the screws.

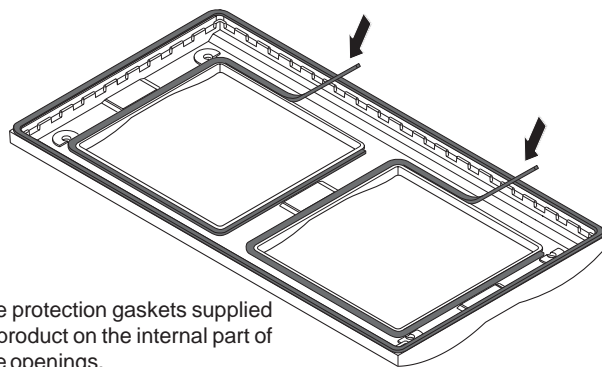

Apply the protection gaskets supplied with the product on the internal part of the frame openings.

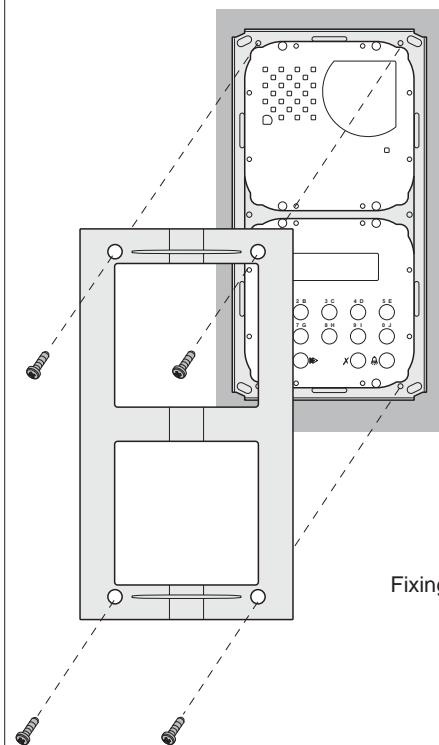

Fixing of frame to module frame.



The power supply is not provided with fuses, but it is protected against overloading or short-circuiting by a heat sensor (thermoprotector), to restore power, it is necessary to cut off the mains voltage for about one minute. Reconnect power after having repaired the fault.

Do not obstruct the openings or the ventilation or heat ejection slots to allow the equipment to operate correctly.

The power supply can be installed on DIN rail or screwed to the wall.

All power supplies can provide power for a maximum of **6 24V-3W lamps** for illuminating push-button panel name plates. For more than 6 lamps, **PRS210** transformer should be installed.

General technical data

Input voltage: 127Vac or 220-230Vac
 Working temperature: 0°±+40°C
 Maximum of humidity: 90%RH

Warning

All power supplies in this manual can work either 127Vac or 220-230Vac.

Check carefully the right connection.

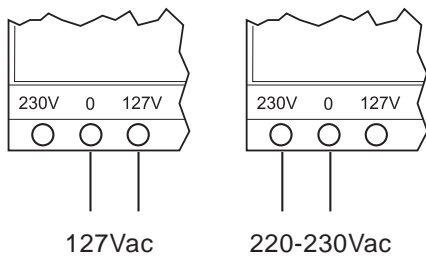

TRANSFORMER

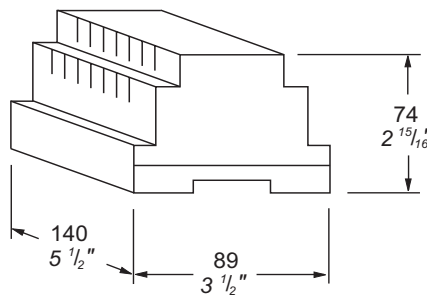

2220. Transformer that can be used to power the door station for DUO system and electric door locks connected to it.

Technical data

Mains voltage: 127 or 220-230Vac
 Frequency: 50/60Hz
 Power: 16VA
 Output voltage: 13Vac±1
 Maximum current: 1A
 Output protection: PTC
 Housing: DIN8 modules A
 Operating temperature: 0°±+40°C
 Maximum permissible humidity: 90%RH

Terminals

~ AC voltage output (13Vac)

TRANSFORMER

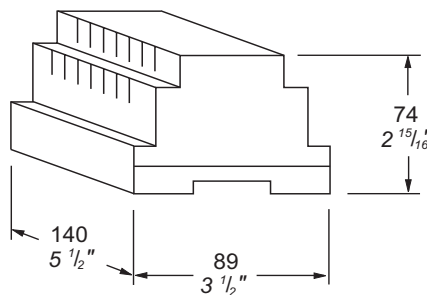

2221. Line power supply that can be used to power the line driver 2222.

Technical data

Mains voltage: 127 or 220-230Vac
 Frequency: 50/60Hz
 Power: 50VA
 Output voltage: 40Vac±1
 Maximum current: 1A
 Output protection: PTC
 Housing: DIN8 modules A
 Operating temperature: 0°±+40°C
 Maximum permissible humidity: 90%RH

Terminals

~ AC voltage output (40Vac)

LINE DRIVER

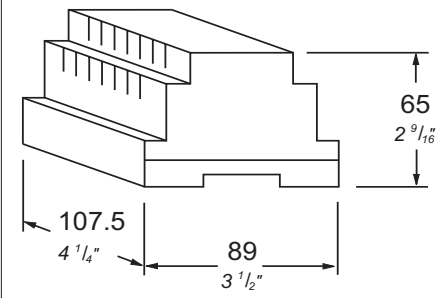

2222. Device to power up to 40 videointercoms with a proper audio, video and data impedance for the correct operation of the DUO system. The maximum allowed distance from the device to the last videointercom is 200m using the Aci Farfisa cable art.2302. In housing DIN bar 6 modules A.

Terminals

LP/LP Line output
 ~ AC voltage input (13Vac)

LINE DISTRIBUTOR



DV2421. It allows to distribute the line signal from the riser to the internal station. It is with terminal (J1) that let you adjust the line impedance according to the installation requirements.

Terminals

LM User output
 LI Line input
 LO Line output

J1 Jumper to select impedance termination line

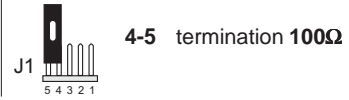
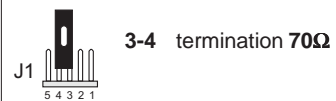
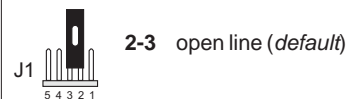

INSTALLATION INSTRUCTIONS

Main features

The cable runs in any video intercom system must be kept separate from the electrical or industrial installation as required by the **International Standards**. In each Country the Installer must comply with the technical and safety regulations stated by their own Government or Technical Committee. In the following are reported only some general rules:

- A protective circuit breaker must be installed on the power supply line. A single general circuit breaker must be used in case of multiple power supply units (also with multiple entrances).
- Before connecting the power supply make sure that the rating complies with the electrical mains.

Note. In installations with digital encoding module using the button modules MA22S and MA24S, it is recommended to power the nameholders LED's with 13 Vac supplementary transformer with proper power. Consumption of each module is 75mA.

Electric door lock

As shown in the installation diagrams the electric lock can be operated using the same power supply which powers the door station, but for a correct operation the electric lock must be a 12VAC/1A max type. During the release of the electric lock the video signal can be disturbed. To avoid this inconvenient or to operate a powerful electric lock it would be advisable to use an extra power supply as reported in the following diagram.

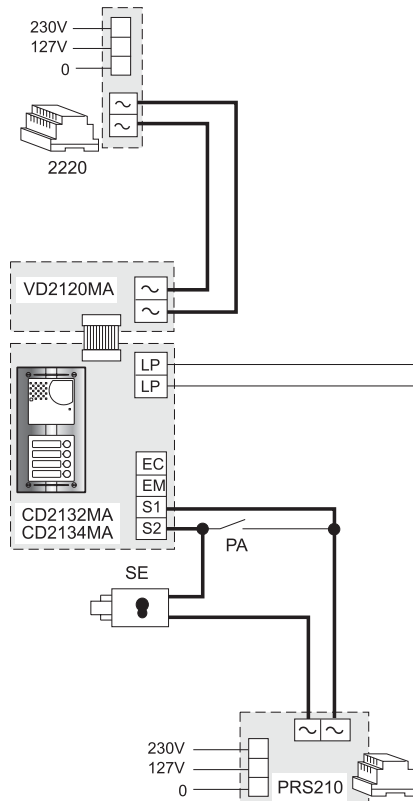

VERY IMPORTANT

To comply with the European Standards on Electromagnetic Compatibility and to increase the reliability of the product, it is necessary to connect a suppression device when switching inductive loads i.e. electric releases and electric locks.

The enclosed suppression devices (transil) must be connected as close as possible to the loads (ideally across the terminals. See figure).

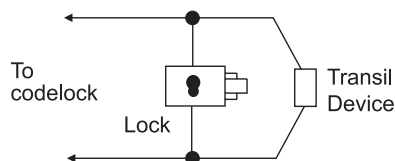

Conductors

DUO digital systems must be cabled using only the cable art.2302 supplied by ACI Farfisa. The use of different cables can influence negatively the characteristics of the system and do not guarantee its performances.

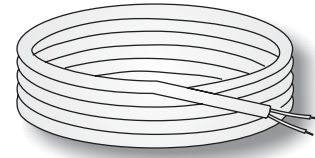

2302. Twisted pair cable specified for the digital installation with DUO systems.

Technical characteristics of cable

Number of conductors	2 (red/black)
Cross-section of conductors	2x1mm ²
Material of conductors	tinned copper
Twisting pitch	40mm
Nominal impedance	100Ω

INSTALLATION INSTRUCTIONS

Maximum distances guaranteed by cable art.2302

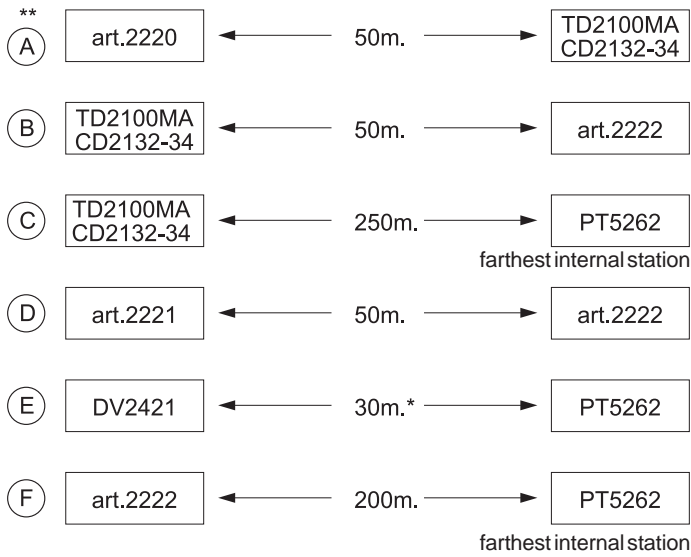

Notes

- * The total length of cables from line distributors to internal stations should not exceed 300m. (adding all the "E" sections).
- ** Letters for reference on the diagrams (see pages 26, 27, 28 and 29).

Schematic for distance calculation

Video intercom system to 1 external station and 1 riser

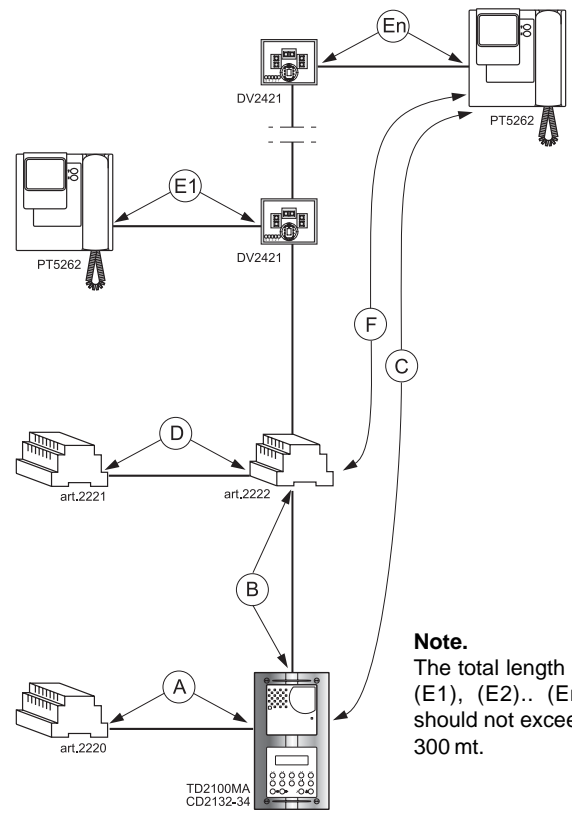

Note.
The total length of (E1), (E2).. (En) should not exceed 300 mt.

Video intercom system to 2 external stations and 2 risers

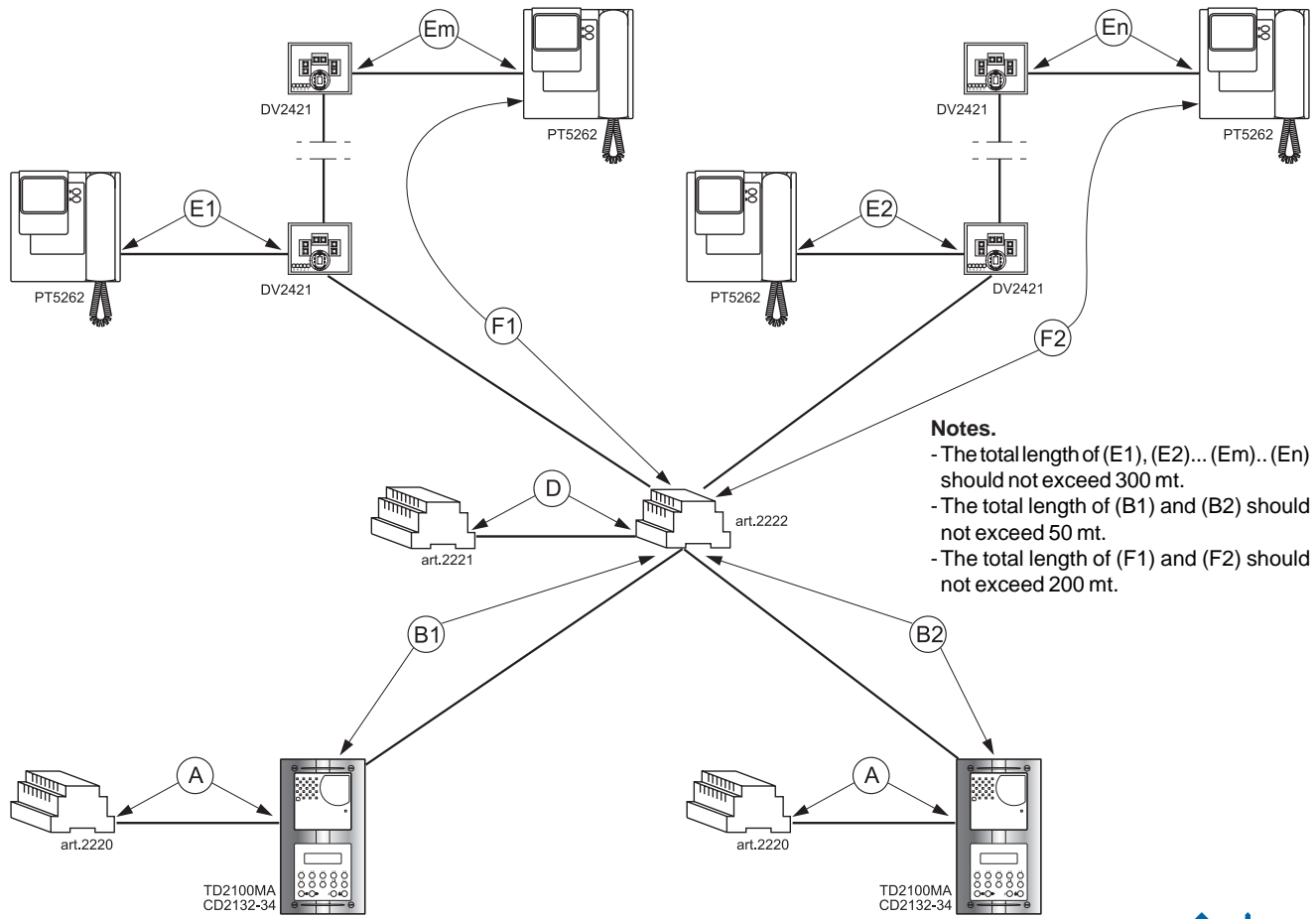

- Notes.**
- The total length of (E1), (E2)... (Em).. (En) should not exceed 300 mt.
 - The total length of (B1) and (B2) should not exceed 50 mt.
 - The total length of (F1) and (F2) should not exceed 200 mt.



INSTALLATION DIAGRAMS

INTERCOMMUNICATING SERVICE

Two following schematics can be used in all the installations. They allow to have intercommunicating service inside a single flat.

In order to get this service, it is necessary to correctly program videointercoms (please see the chapters "Programming users and intercommunicating address" and "Programming codes to be assigned to the additional buttons" on page 4). Please see page 4 and 5 for operating mode.

2 INTERCOMMUNICATING VIDEO INTERCOMS

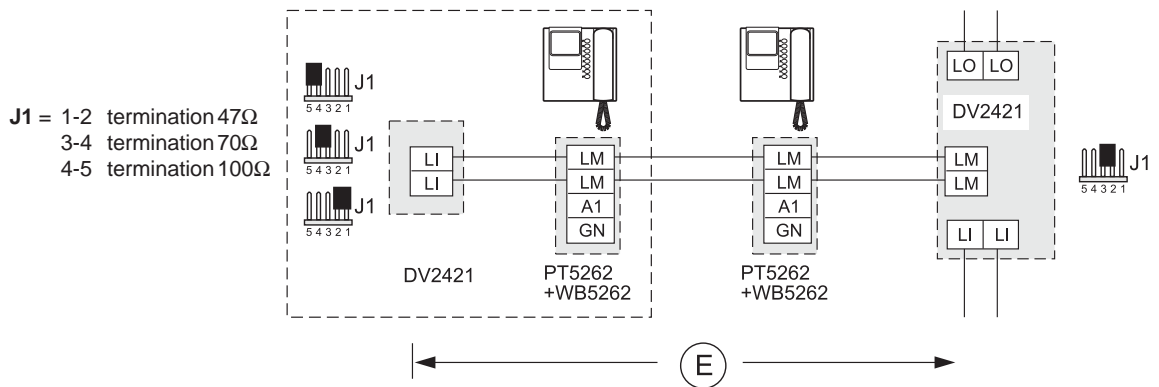

3 INTERCOMMUNICATING VIDEO INTERCOMS

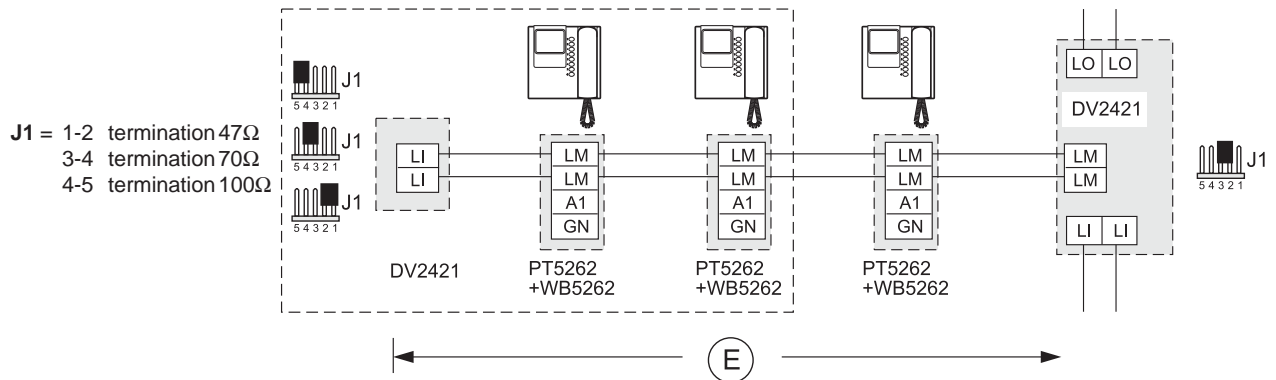

In the squared pictures the additional items to the basic schematics on page 26, 27, 28 and 29 are described.
For the distance (E) please see on page 24.



VIDEO INTERCOMS CONNECTED TO A EXTERNAL STATION

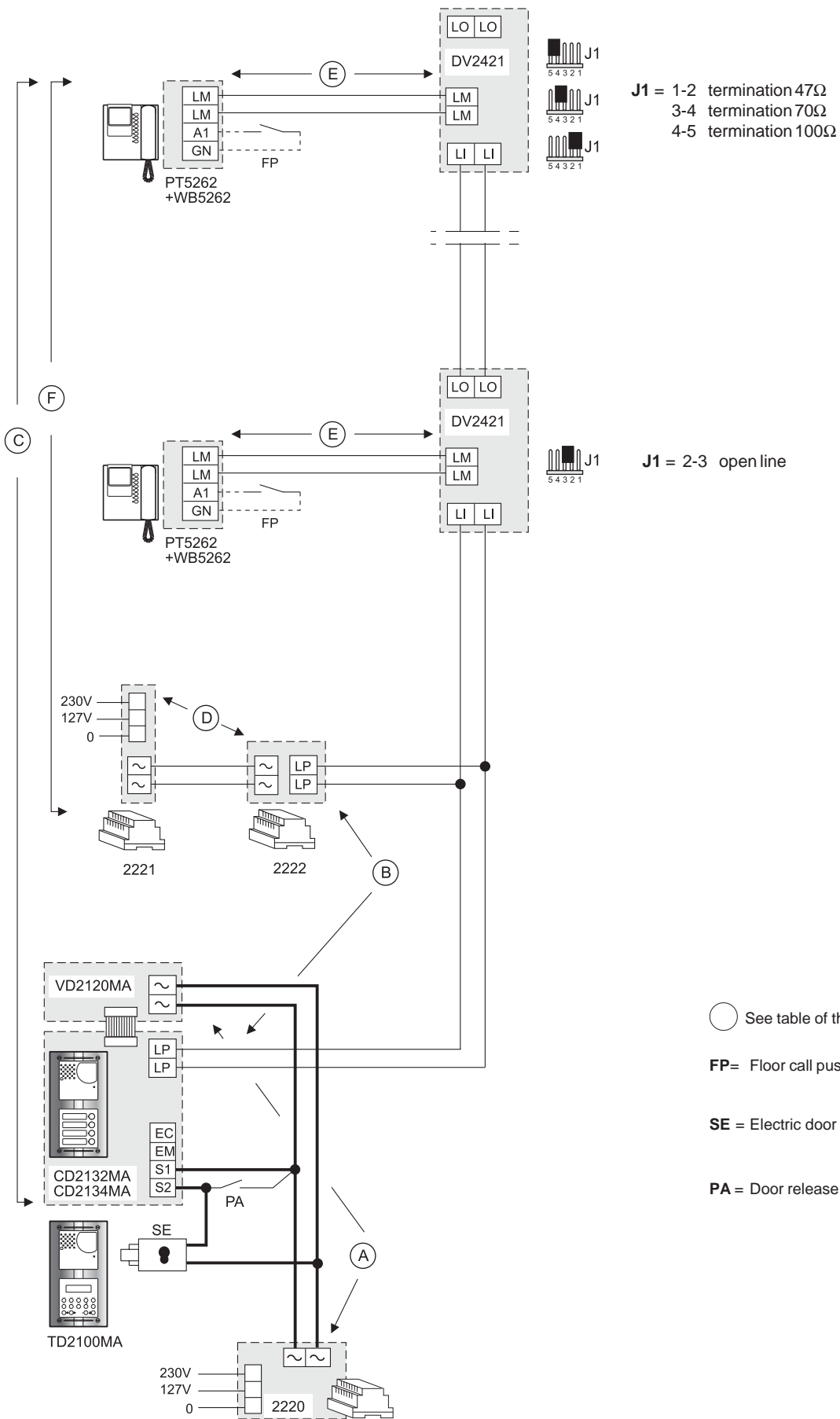

VIDEO INTERCOMS CONNECTED TO TWO EXTERNAL STATIONS

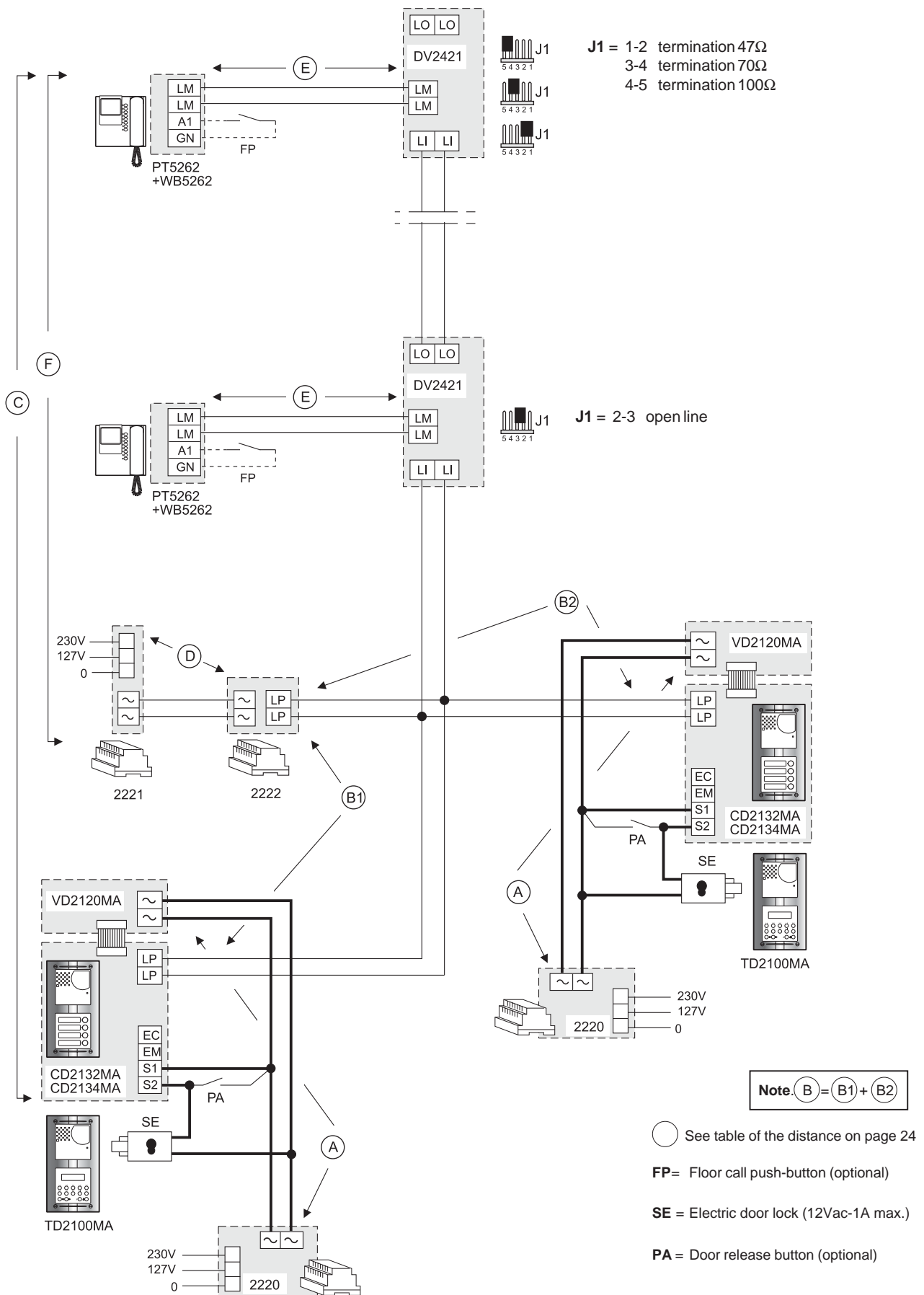

VIDEO INTERCOMS CONNECTED TO TWO EXTERNAL STATIONS AND TWO VIDEO RISERS

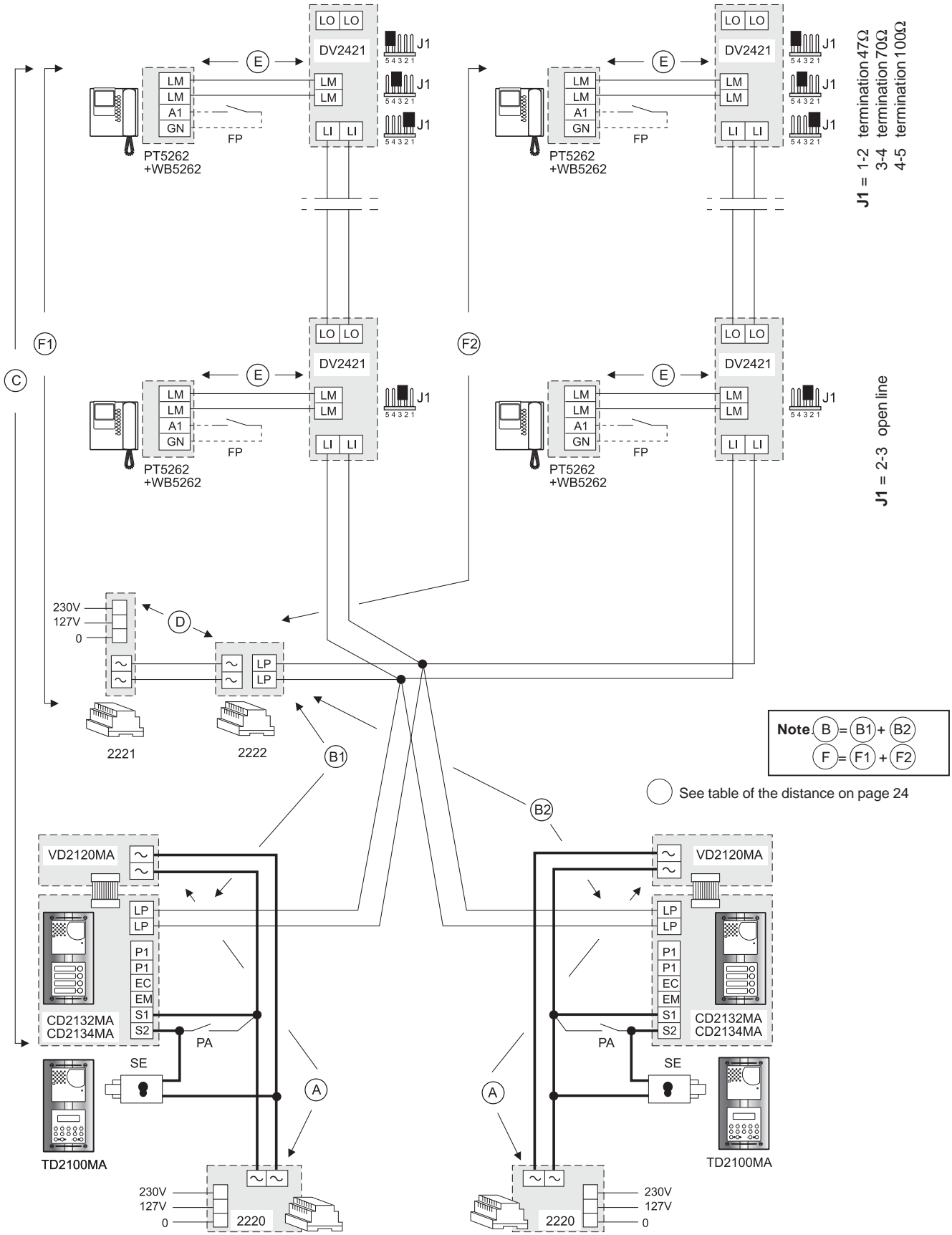

FP= Floor call push-button (optional)

SE = Electric door lock (12Vac-1A max.)

PA = Door release button (optional)



VIDEO INTERCOMS CONNECTED TO TWO EXTERNAL STATIONS AND THREE VIDEO RISERS

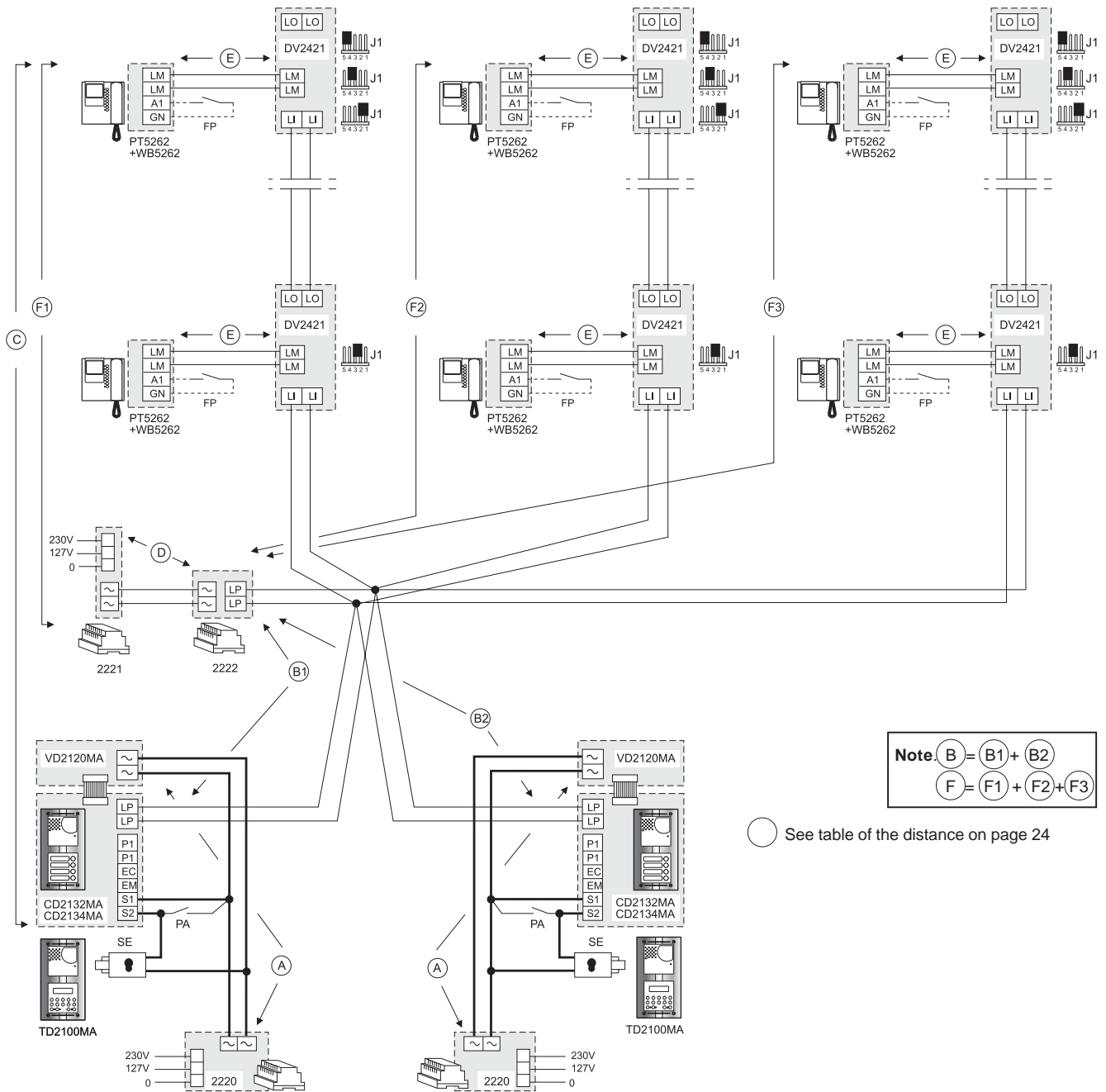
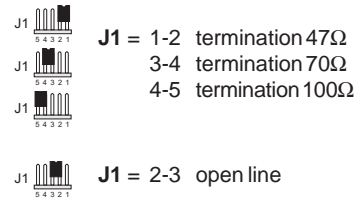

Note. B = B1 + B2
 F = F1 + F2 + F3

○ See table of the distance on page 24

FP= Floor call push-button (optional)

SE = Electric door lock (12Vac-1A max.)

PA = Door release button (optional)

