



FAAC para la naturaleza
100% papel reciclado



FAAC ist umweltfreundlich
100% Altpapier



FAAC pour la nature
papier recyclé 100%



FAAC for nature
recycled paper 100%



FAAC per la natura
carta riciclata 100%

Technical file

Guide for the drafting

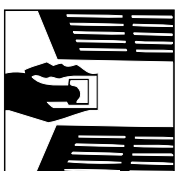
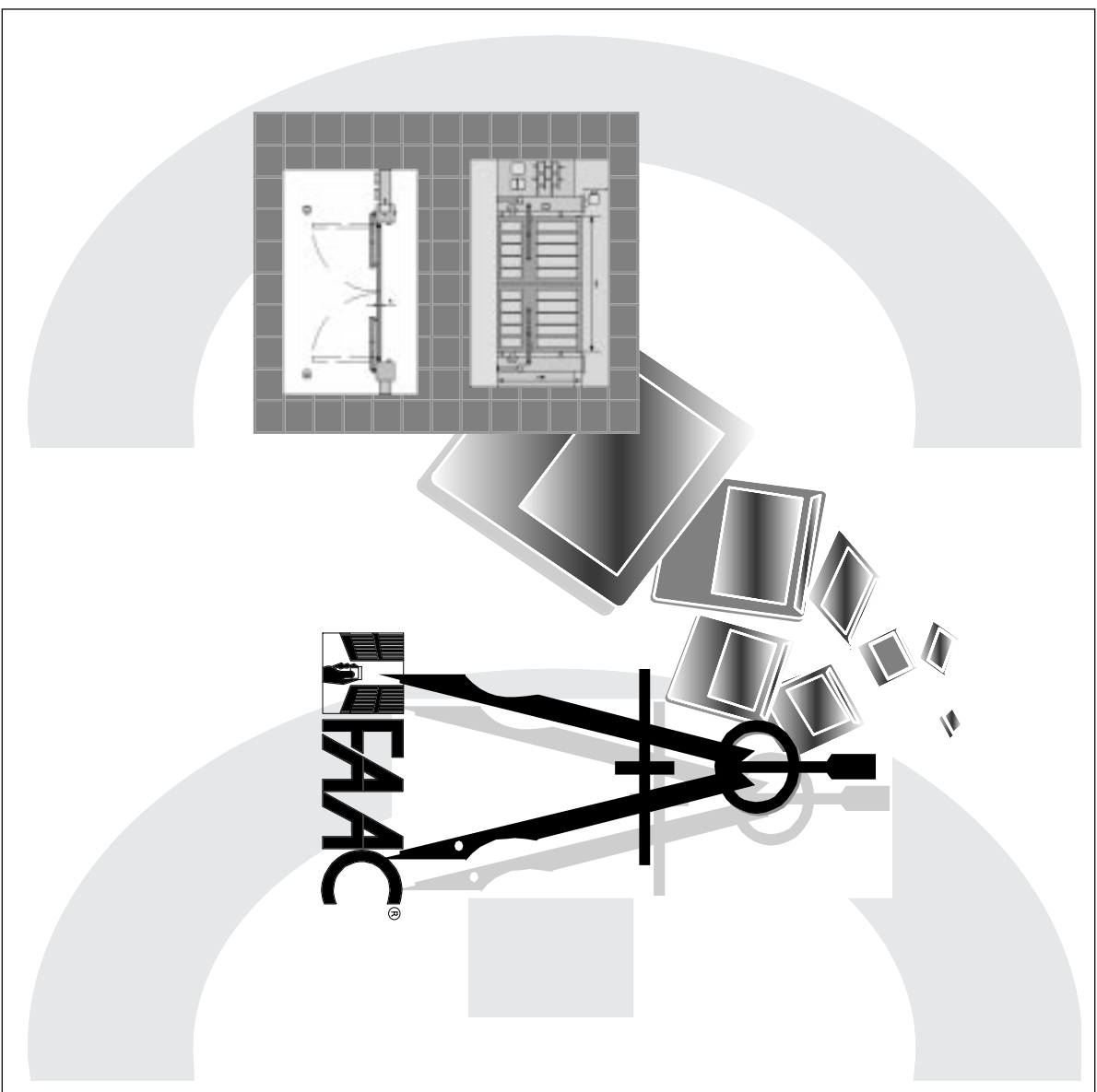

FAAC



Le descrizioni e le illustrazioni del presente manuale non sono impegnative. La FAAC si riserva il diritto, lasciando inalterate le caratteristiche essenziali dell'apparecchiatura, di apportare in qualunque momento e senza impegnarsi ad aggiornare la presente pubblicazione, le modifiche che essa ritiene convenienti per miglioramenti tecnici o per qualsiasi altra esigenza di carattere costruttivo o commerciale.

The descriptions and illustrations contained in the present manual are not binding. FAAC reserves the right, whilst leaving the main features of the equipments unaltered, to undertake any modifications it holds necessary for either technical or commercial reasons, at any time and without revising the present publication.

Les descriptions et les illustrations du présent manuel sont fournies à titre indicatif. FAAC se réserve le droit d'apporter à tout moment les modifications qu'elle jugera utiles sur ce produit tout en conservant les caractéristiques essentielles, sans devoir pour autant mettre à jour cette publication.

Die Beschreibungen und Abbildungen in vorliegendem Handbuch sind unverbindlich. FAAC behält sich das Recht vor, ohne die wesentlichen Eigenschaften dieses Gerätes zu verändern und ohne Verbindlichkeiten in Bezug auf die Neufassung der vorliegenden Anleitungen, technisch bzw. konstruktiv/kommerziell bedingte Verbesserungen vorzunehmen.

Las descripciones y las ilustraciones de este manual no comportan compromiso alguno. FAAC se reserva el derecho, dejando inmutadas las características esenciales de los aparatos, de aportar, en cualquier momento y sin comprometerse a poner al día la presente publicación, todas las modificaciones que considere oportunas para el perfeccionamiento técnico o para cualquier otro tipo de exigencia de carácter constructivo o comercial.

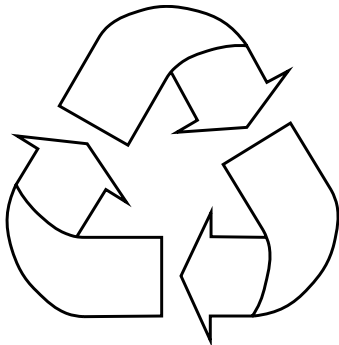

FAAC per la natura

- La presente istruzione è realizzata al 100% in carta riciclata.
- Non disperdete nell'ambiente gli imballaggi dei componenti dell'automazione bensì selezionate i vari materiali (es. cartone, polistirolo) secondo prescrizioni locali per lo smaltimento rifiuti e le norme vigenti.

FAAC for the environment

- The present manual is produced in 100% recycled paper
- Respect the environment. Dispose of each type of product packaging material (card, polystyrene) in accordance with the provisions for waste disposal as specified in the country of installation.

FAAC der Umwelt zuliebe

- Vorliegende Anleitungen sind auf 100% Altpapier gedruckt.
- Verpackungstoffe der Antriebskomponenten (z.B. Pappe, Styropor) nach den einschlägigen Normen der Abfallwirtschaft sortenrein sammeln.

FAAC écologique

- La présente notice a été réalisée 100% avec du papier recyclé.
- Ne pas jeter dans la nature les emballages des composants de l'automatisme, mais sélectionner les différents matériaux (ex.: carton, polystyrène) selon la législation locale pour l'élimination des déchets et les normes en vigueur.

FAAC por la naturaleza

- El presente manual de instrucciones se ha realizado, al 100%, en papel reciclado.
- Los materiales utilizados para el embalaje de las distintas partes del sistema automático (cartón, poliestireno) no deben tirarse al medio ambiente, sino seleccionarse conforme a las prescripciones locales y las normas vigentes para el desecho de residuos sólidos.



FAAC

FAAC S.p.A.
Via Benini, 1
40069 Zola Predosa (BO) - ITALIA
Tel.: 051/6172411 - Tlx.: 521087
Fax: 051/758518

Timbro del Rivenditore:/Distributor's Stamp:/Timbre de l'Agent:/ Fachhändlerstempel:/Sello del Revendedor:



ANIMA

FEDERAZIONE DELLE ASSOCIAZIONI
NAZIONALI DELL'INDUSTRIA MECCANICA
VARIA ED AFFINE



ASSOCIAZIONE NAZIONALE COSTRUTTORI DI
INFISSI MOTORIZZATI E DI AUTOMATISMI PER
SERRAMENTI IN GENERE



Manufacturer:

(Name, address, telephone)

GUIDELINES FOR THE DRAFTING OF A TECHNICAL FILE FOR POWER OPERATED DOORS AND GATES PURSUANT TO MACHINERY DIRECTIVE 89/392/EEC

Description of door:

(Model, type, serial number etc.)

Location:

(address)

CONTENTS

Introduction	page	1
Contents of technical file	page	2
Drafting	page	2
Key to mechanical movement risks (with ref. to Table 1)	page	2
Guidelines for risk analysis for power operated door - Table 1	page	3
List of applicable standards	page	4
Facsimile of CE marking plate	page	4
Proof book	page	5-6
EC declaration of conformity	page	7
Assembly drawing of power operated door (danger zones) - Figure 1/(A-N)	page	8
Electrical connection diagram - Figure 2/(A-N)	page	8
List of installed components (with ref. to Fig. 2) - Table 2	page	8

INTRODUCTION

For the purposes of Art. 1.2 of Machinery Directive 89/392/EEC "**machinery**" means an assembly of linked parts or components, at least one of which moves, with the appropriate actuators, control and power circuits, etc. joined together for a specific application, in particular for the processing, treatment, moving or packaging of a material."

In this documents the term "**door**" means doors, shutters and gates of various kinds (sliding, folding, up-and-over, swing, rolling, vertical sliding and other types with variants for each type).

The term "**manufacturer**" is used for the party that supplies the power operated door or the party that motorises an existing manual door, or the party that affixes the CE marking to the power operated door and thereby assumes responsibility for the construction of said door.

The European Union Commission has established that power operated doors and gates come within the field of application of the Machinery Directive. Therefore the installer who motorises a door or gate has the same obligations as the manufacturer of machinery and as such must:

- prepare the technical file which must contain the documents indicated in Annex V of the Machinery Directive;
(The technical file must be kept and placed at the disposal of competent national authorities for at least ten years from the date of manufacture of the power operated door);
- draft the EC declaration of conformity in accordance with Annex II-A of the MACHINERY DIRECTIVE;
- affix the CE marking on the power operated door in accordance with point 1.7.3 of Annex I of the MACHINERY DIRECTIVE.

UNAC will accept no responsibility for the use that is made of this document or for amendments to the cited standards and their fulfilment. This document has been drafted by a working group consisting of representatives of the following UNAC member companies: Automatismi Benincà srl, BFT srl, Casit sas, Ditec spa, FAAC spa, Iseo Serrature spa, O.L.V.A. srl, Sesamo srl.

CONTENTS OF TECHNICAL FILE

The technical file must contain the following documents:

- An assembly drawing of the power operated door.
- Electric connection and control circuit diagrams.
- Risks analysis including:
 - a list of the essential requirements specified in Annex I of the Machinery Directive;
 - a list of the risks posed by the power operated door and a description of the solutions adopted.
- The installation and maintenance manuals for the drive system and components.
- The operating instructions and general safety warnings (copy to be given to user).
- The proof book (copy to be given to user).
- The EC declaration of conformity (copy to be given to user).

DRAFTING

1. Insert the manufacturer's data and the data for the door in the appropriate boxes on the first page.
2. Choose the type of door.
 - A SLIDING GATE
 - B SWING GATE
 - C UP-AND-OVER DOOR
 - D SECTIONAL DOOR
 - E VERTICAL SLIDING DOOR
 - F FOLDING SLIDING DOOR
 - G BARRIER
 - H SHUTTER
 - I ROLLING FLEXIBLE DOOR
 - L SLIDING PEDESTRIAN DOOR
 - M SWINGING PEDESTRIAN DOOR
 - N _____ (other type of door)
3. Adapt Figure 1/(A-N) on page 8 to the constructed system and complete it by indicating any missing danger zones.
4. Adapt the electrical diagram and the components of Figure 2/(A-N) on page 8 to the constructed system.
5. Adapt and complete table 2 on page 8 with the components present in the system.
6. Perform risk analysis using Table 1 on page 3.
 - Tick the risks present in the constructed system out of those listed in the column "Type of risk" and tick the corresponding adopted solutions listed in the column "Evaluation criteria and solutions adopted".
 - For mechanical risks due to movement of the door, insert the capital letters of Figure 1/(A-N) on page 8, indicating the danger zones in the column "Dangerous zones and/or parts".
 - For each danger zone indicate the corresponding risks (numbered from 1 to 7) in the column "Risk considered".
 - Indicate the "Adopted solution" with lower-case letters in the relevant column.
 - Insert additional observations in the relevant space in Table 1.
7. Tick the considered standards listed on page 4.
8. Enter the requested data and the necessary signatures in the proof book on pages 5 and 6.
9. Complete and sign the EC Declaration of Conformity on page 7.
10. Prepare the CE marking plate and affix it to the power operated door (see facsimile on page 4).

KEY TO MECHANICAL MOVEMENT RISKS (with ref. to Table 1)

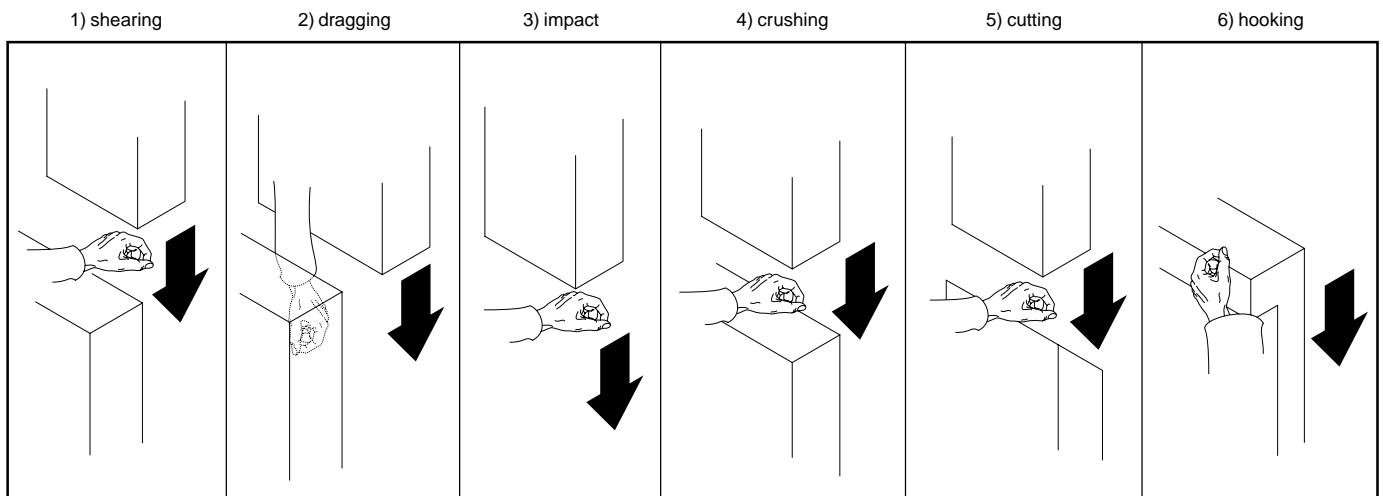

Point 1.1.1 of Annex I of the Machinery Directive establishes the following meanings:

- *Danger zone:* any zone within and/or around machinery in which an exposed person is subject to a risk to his health or safety.
- *Exposed person:* Any person wholly or partially in a danger zone.

GUIDELINES FOR RISK ANALYSIS FOR POWER OPERATED DOOR - Table 1

TYPE OF RISK (Tick the risks considered)	Annex I of Machinery Directive	EVALUATION CRITERIA AND SOLUTIONS ADOPTED (Tick the box corresponding to the solution adopted)			
Integration principles for safety and information: <input type="checkbox"/> unprotected residual risks <input type="checkbox"/> signalling equipment <input type="checkbox"/> warnings <input type="checkbox"/> marking <input type="checkbox"/> operating instructions	1.1.2 1.7.1 1.7.2 1.7.3 1.7.4	<input type="checkbox"/> User informed about presence of unprotected residual risks and foreseeable abnormal use. <input type="checkbox"/> Flashing light, signals, siren etc. installed. <input type="checkbox"/> Warning affixed indicating presence of residual risks. <input type="checkbox"/> CE marking applied to power operated door. <input type="checkbox"/> User given operating instructions and safety warnings.			
Ergonomic risks: <input type="checkbox"/> effort for manual operations	1.1.2 - 1.3.7	<input type="checkbox"/> Checked that manual operations do not require excessive effort.			
Structural mechanical and wear risks: <input type="checkbox"/> loss of stability <input type="checkbox"/> break-up <input type="checkbox"/> tripping <input type="checkbox"/> guides, chains and lifting ropes	1.3.1 1.3.2 1.5.15 4.1.2	<input type="checkbox"/> Solidity of the structure checked, appropriate materials used and adequate means of anchorage provided. <input type="checkbox"/> Appropriate operations and adjustments performed to prevent detachment of leaves. <input type="checkbox"/> Checked that thresholds are appropriately modelled and marked. <input type="checkbox"/> Presence and efficiency of system to prevent falling of mobile parts checked.			
Mechanical risks due to movement of doors. Choice of protective devices. <i>(Indicate the risk considered in the second column of the table, right)</i> 1) shearing 2) dragging 3) impact 4) crushing 5) cutting 6) hooking 7) other:	1.3.8 - 1.4 1.3.7 1.3.7 1.3.7 1.3.7 1.3.4 1.3.7	Dangerous zones and/or parts <i>Ref. to Figure 1/(A-N)</i>	Risk considered	Solution adopted	List of applicable solutions <i>(Indicate the solution in the third column of the table, left)</i> a) Hold-to-run controls b) Safety edges c) Photocells d) Safety distances e) Force limiters f) Shaping surfaces g) Pressure-sensitive mats h) Detectors (Radar) i) Acoustic signalling l) Visual signalling m) Warnings n) Guards o) Other:
Electrical risks: <input type="checkbox"/> direct and indirect contact <input type="checkbox"/> dispersion of electrical energy <input type="checkbox"/> climatic and environmental risks	1.5.1 - 1.5.2	<input type="checkbox"/> CE marked components used pursuant to Low Voltage Directive (73/23/EEC). <input type="checkbox"/> Electrical connections and hook-up to mains performed in accordance with relevant applicable standards and as indicated by the manufacturer of the drive unit. <input type="checkbox"/> Compatibility of power operated door with critical environmental conditions verified.			
Risks relating to electromagnetic compatibility	1.5.10 1.5.11	<input type="checkbox"/> CE marked components used pursuant to EMC Directive (89/336/EEC).			
Safety and reliability of operator and control devices: <input type="checkbox"/> safety condition in the event of malfunction or failure of power supply <input type="checkbox"/> different energy sources from electrical energy <input type="checkbox"/> control devices <input type="checkbox"/> consistency of controls <input type="checkbox"/> emergency stop <input type="checkbox"/> trapping	1.2.1 - 1.2.7 1.2.6 1.5.3 1.2.2 1.2.5 1.2.4 1.5.14	<input type="checkbox"/> An drive unit and control devices adequate for use and meeting current applicable standards used. <input type="checkbox"/> An drive unit meeting current applicable standards used. <input type="checkbox"/> Control devices adequate for use and meeting current applicable standards installed. <input type="checkbox"/> Checked that the control is consistent with the movement of the door and the instructions. <input type="checkbox"/> Emergency stop or opening device installed. <input type="checkbox"/> Release device installed to allow for manual operation.			
Risks deriving from: <input type="checkbox"/> fluid materials <input type="checkbox"/> high temperatures <input type="checkbox"/> fire <input type="checkbox"/> explosion <input type="checkbox"/> noise <input type="checkbox"/> vibrations	1.1.3 1.5.5 1.5.6 1.5.7 1.5.8 1.5.9	<input type="checkbox"/> Checked that the fluids used do not cause danger and that they are not released into the environment. <input type="checkbox"/> Checked that the materials used do not reach high temperatures during use. <input type="checkbox"/> Checked that the materials used do not cause fires. <input type="checkbox"/> Checked that flammable gases are absent. <input type="checkbox"/> Checked that the power operated door does not cause dangerous noise. <input type="checkbox"/> Checked that the power operated door is not the source of dangerous vibrations.			
Maintenance: <input type="checkbox"/> operative procedures <input type="checkbox"/> disconnecter supply <input type="checkbox"/> documentation	1.6.1 1.6.3	<input type="checkbox"/> Maintenance work program planned and implemented at established intervals. <input type="checkbox"/> Presence of a switch or plug-in system to isolate energy supply checked. <input type="checkbox"/> Maintenance work recorded and EC Declaration of Conformity issued to user.			
Additional remarks: <hr/> <hr/> <hr/>					

LIST OF APPLICABLE STANDARDS

(Tick the standards considered)

European standards:

- prEN 12453 Industrial, commercial and garage doors and gates
Safety in the use of power operated doors - Requirements and classification
- prEN 12445 Industrial, commercial and garage doors and gates
Safety in the use of power operated doors - Test methods
- prEN 12604 Industrial, commercial and garage doors and gates
Mechanical aspects - Requirements and classification
- prEN 12605 Industrial, commercial and garage doors and gates
Mechanical aspects - Test methods
- prEN 12635 Industrial, commercial and garage doors and gates
Procedure for safe installation and use

- prEN 12650-1 Building hardware - Power pedestrian doors
Part 1: Product requirements and test methods
- prEN 12650-2 Building hardware - Power pedestrian doors
Part 2: Safety at powered pedestrian doors

Italian standards:

- CEI 64-8 Electric user systems with rated voltage no higher than 1000 V in alternating current or 1500 V in direct current

Other standards:

- _____
- _____
- _____

FACSIMILE OF CE MARKING PLATE

Each machine must bear in a legible and indelible manner at least the following indications:

- name and address of manufacturer
- CE marking
- series and type designation
- serial number (if any)
- year of construction



NAME OF MANUFACTURER

ADDRESS

DESCRIPTION OF MODEL

SERIAL NUMBER

YEAR OF CONSTRUCTION

The following additional information may be provided:

- NAME AND ADDRESS OF TECHNICAL SERVICE AND MAINTENANCE CENTRE
- MASS OF LEAF IN KG FOR MOBILE ELEMENTS WHICH MUST BE LIFTED IN THE CASE OF OPENING
- ETC.



ANIMA

FEDERAZIONE DELLE ASSOCIAZIONI NAZIONALI DELL'INDUSTRIA MECCANICA VARIA ED AFFINE



ASSOCIAZIONE NAZIONALE COSTRUTTORI DI INFISSI MOTORIZZATI E DI AUTOMATISMI PER SERRAMENTI IN GENERE



Technical service:

(Name, address, telephone number)

PROOF BOOK

This proof book contains technical references and records of installation, maintenance, repair and modification activities carried out and must be made available for public inspection by authorised bodies.

Description of door:

(Model, type, serial number, etc.)

Location:

(Address)

Customer:

(Name, address and reference person)

Technical data:

Leaves:

(Material, dimension, weight)

Installed power:

(Voltage, frequency, current, power)

Type of operation:

(Hold-to-run control, impulse activation, automatic operation)

List of installed components (drive unit, control and safety devices, etc.).

The technical data and specifications of the components listed below are documented in the corresponding installation manuals and/or on the label on the component.

- _____
(Model, type, serial number)
- _____
(Model, type, serial number)
- _____
(Model, type, serial number)
- _____
(Model, type, serial number)
- _____
(Model, type, serial number)
- _____
(Model, type, serial number)
- _____
(Model, type, serial number)
- _____
(Model, type, serial number)
- _____
(Model, type, serial number)
- _____
(Model, type, serial number)
- _____
(Model, type, serial number)

Remarks (special characteristics, etc.).

EC DECLARATION OF CONFORMITY

(Machinery Directive 89/392/EEC, Annex II, part A)

Manufacturer: _____

Address: _____

Declares that: _____

(Model, type, serial number, etc.)

Location: _____

(Address)

- Conforms to the conditions of the Machinery Directive 89/392/EEC and subsequent amendments.
- Conforms to the conditions of the following additional EEC directives:
Electromagnetic Compatibility Directive 89/336/EEC and subsequent amendments;
Low Voltage Directive 73/23/EEC and subsequent amendments.

And also declares that

- the following (parts/clauses of) harmonized standards have been applied:

- the following (parts/clauses of) national standards and technical specifications have been applied:

Date: _____

Signature of Legal Representative: _____

ASSEMBLY DRAWING OF DOOR (DANGER ZONES) - Figure 1/A

N.B.: Strike out the letters indicating danger zones not present and add any that are missing

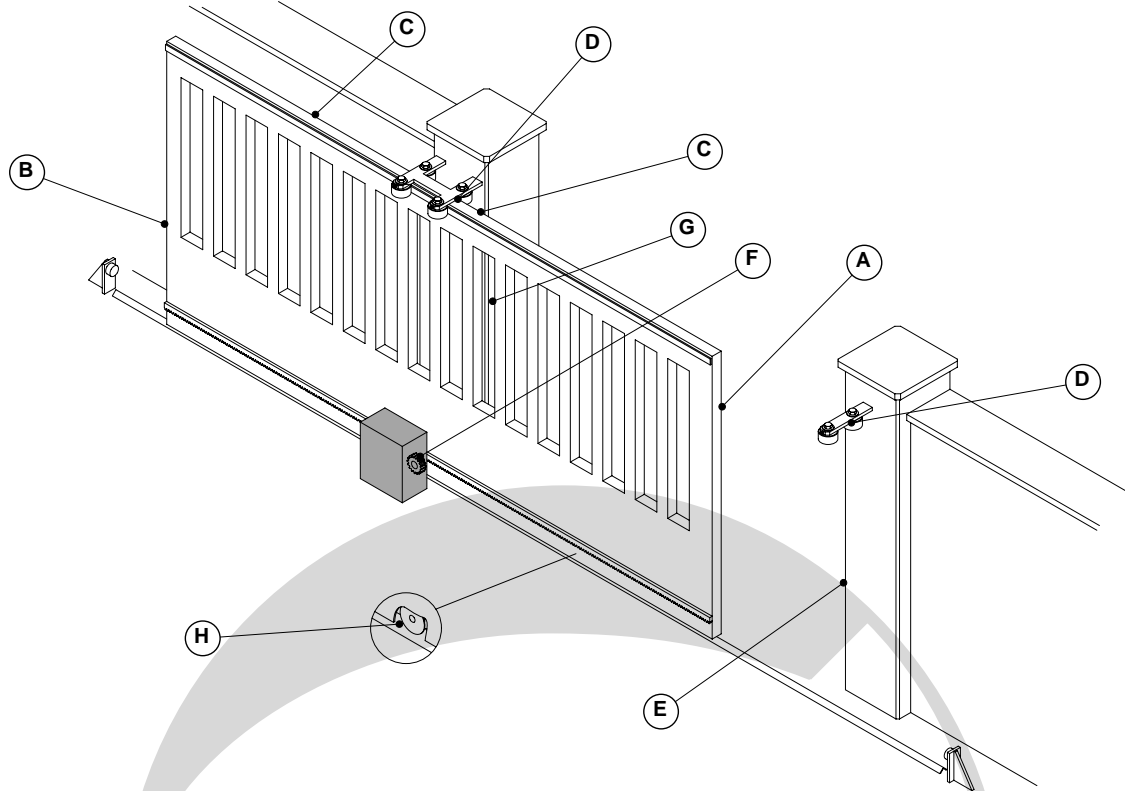

ELECTRICAL CONNECTION DIAGRAM - Fig. 2/A

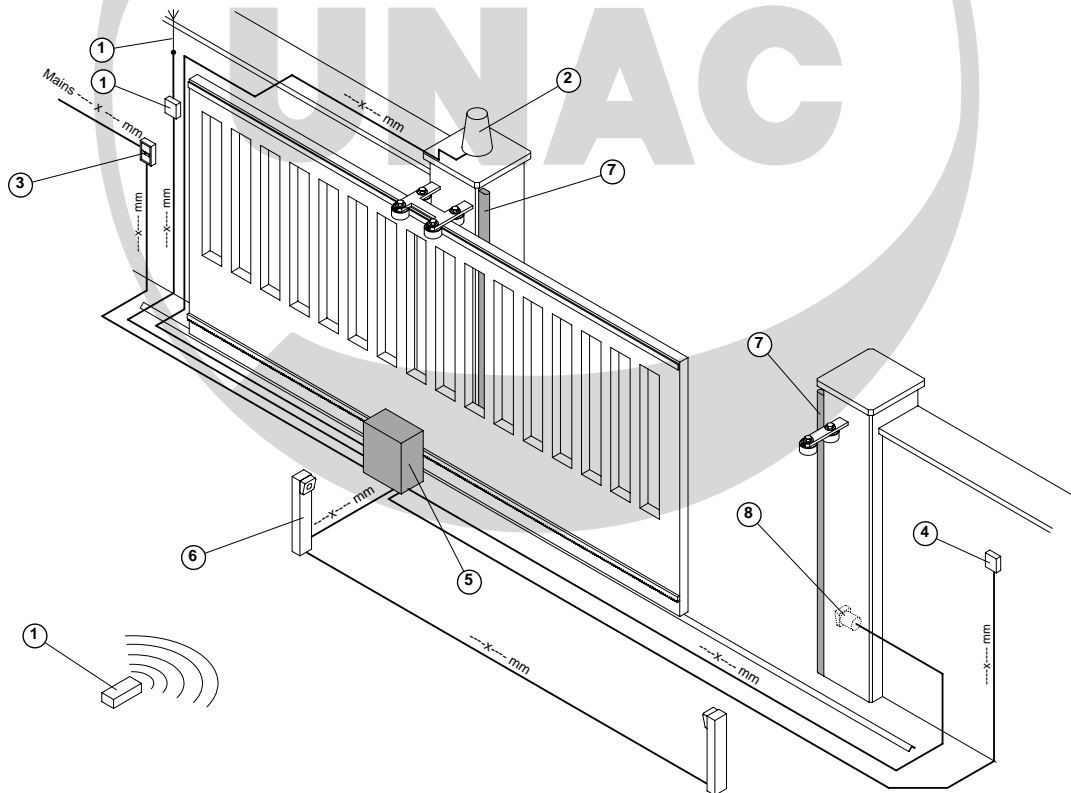

LIST OF INSTALLED COMPONENTS (with ref. to Fig. A) - Table 2

Ref. No.	Description of component	Model / Notes
1	Radio receiver / antenna	
2	Flashing light	
3	Switch / circuit-breaker	
4	Selector / pushbutton	
5	Operator with control panel	
6	Pair of internal photocells	
7	Safety edge	
8	Pair of external photocells	
9		
10		

ASSEMBLY DRAWING OF DOOR (DANGER ZONES) - Figure 1/B

N.B.: Strike out the letters indicating danger zones not present and add any that are missing

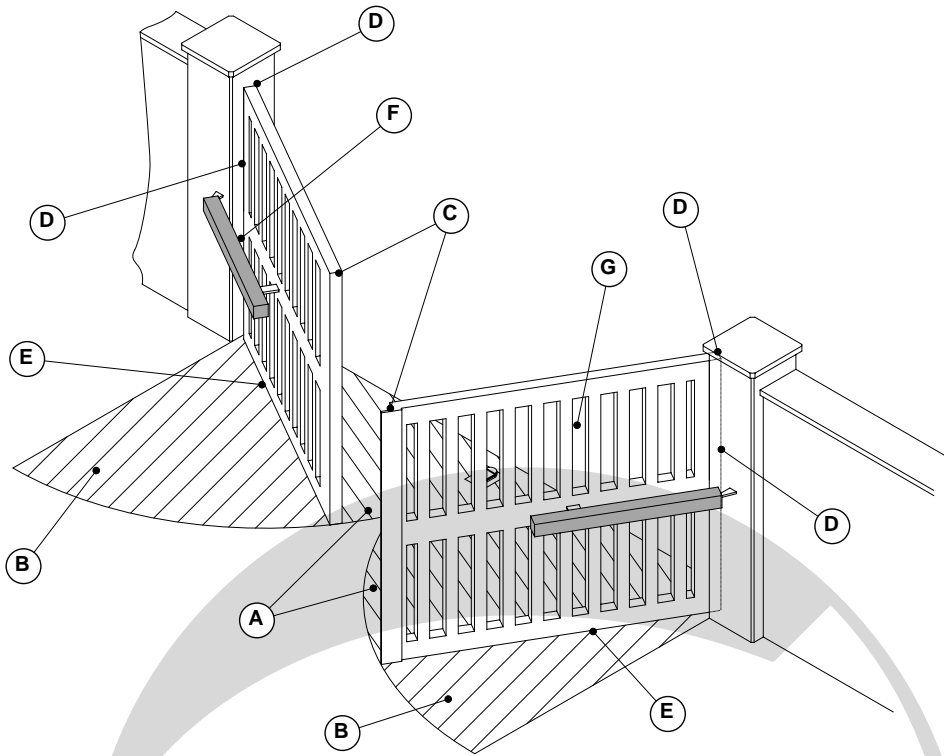

ELECTRICAL CONNECTION DIAGRAM - Fig. 2/B

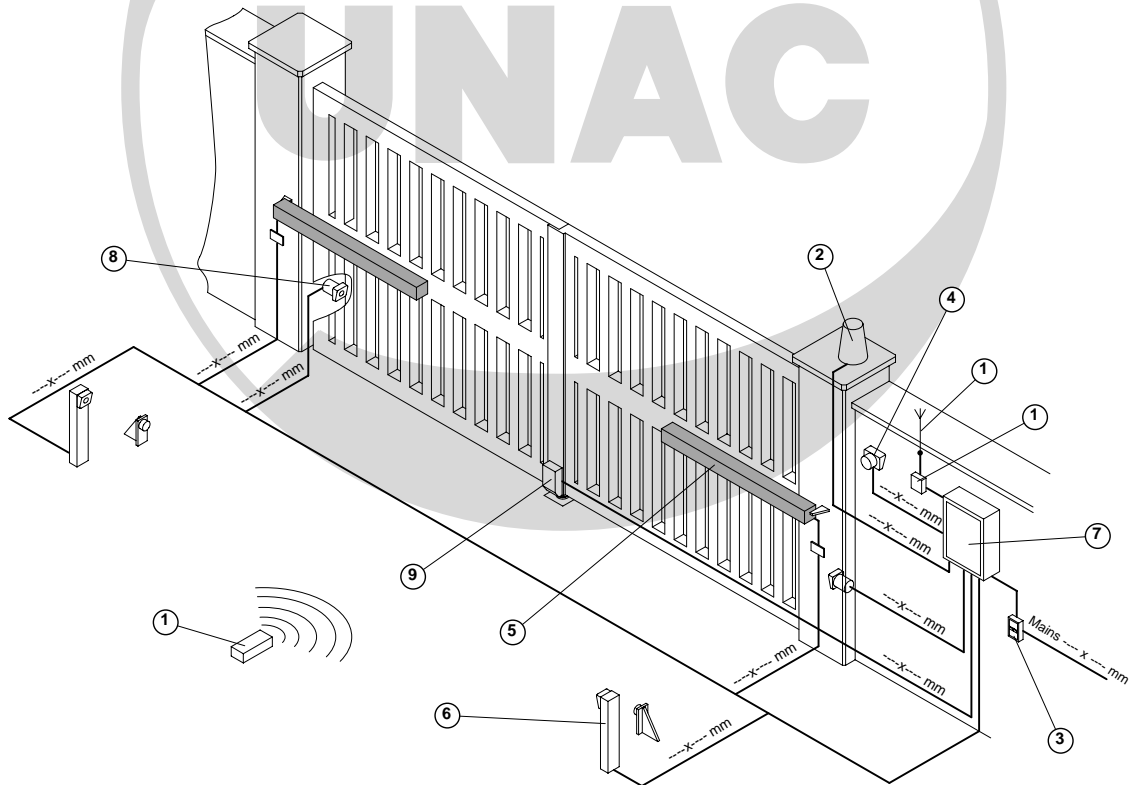

LIST OF INSTALLED COMPONENTS (with ref. to Fig. B) - Table 2

Ref. No.	Description of component	Model / Notes
1	Radio receiver / antenna	
2	Flashing light	
3	Switch / circuit-breaker	
4	Selector / pushbutton	
5	Operator	
6	Pair of internal photocells	
7	Control panel	
8	Pair of external photocells	
9	Electric lock	
10		

ASSEMBLY DRAWING OF DOOR (DANGER ZONES) - Figure 1/C

N.B.: Strike out the letters indicating danger zones not present and add any that are missing

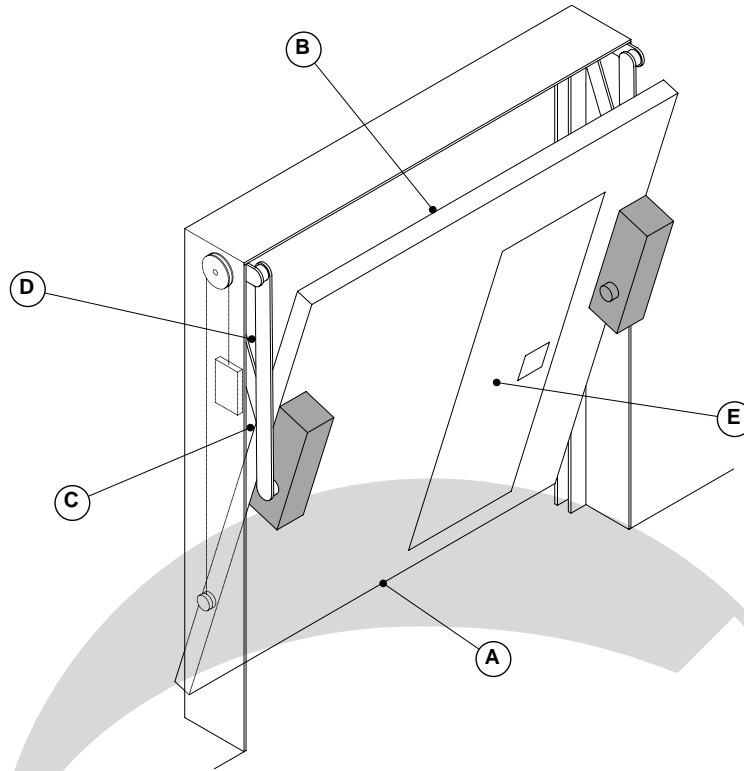

ELECTRICAL CONNECTION DIAGRAM - Fig. 2/C

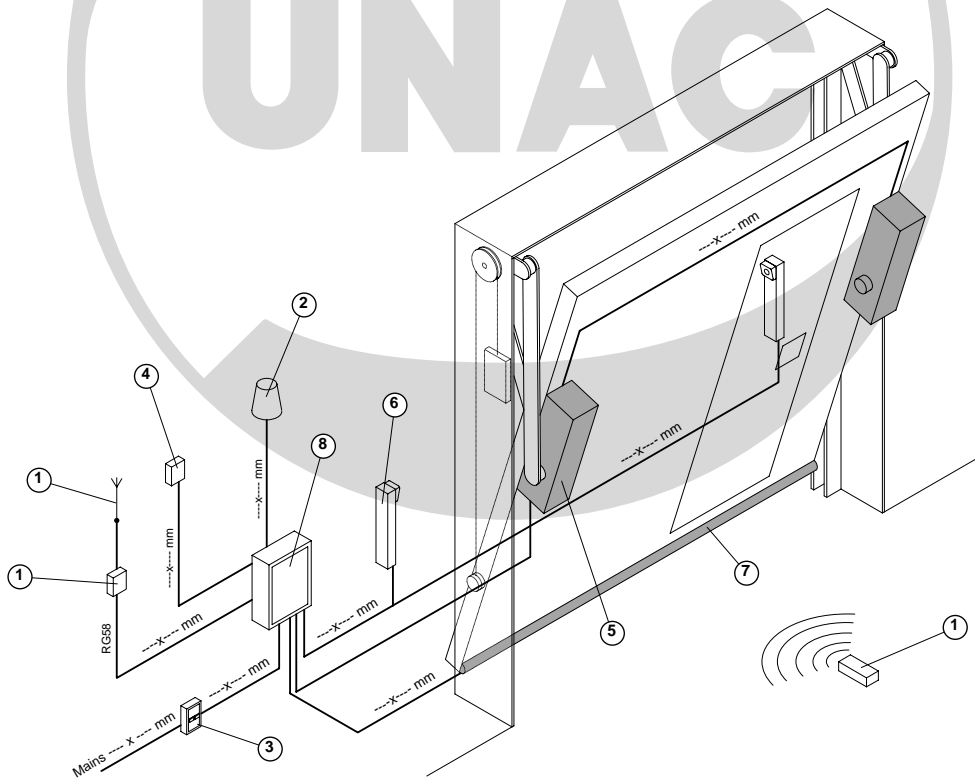

LIST OF INSTALLED COMPONENTS (with ref. to Fig. C) - Table 2

Ref. No.	Description of component	Model / Notes
1	Radio receiver / antenna	
2	Flashing light	
3	Switch / circuit-breaker	
4	Selector / pushbutton	
5	Operator	
6	Photocells	
7	Safety edge	
8	Control panel	
9		
10		

ASSEMBLY DRAWING OF DOOR (DANGER ZONES) - Figure 1/D

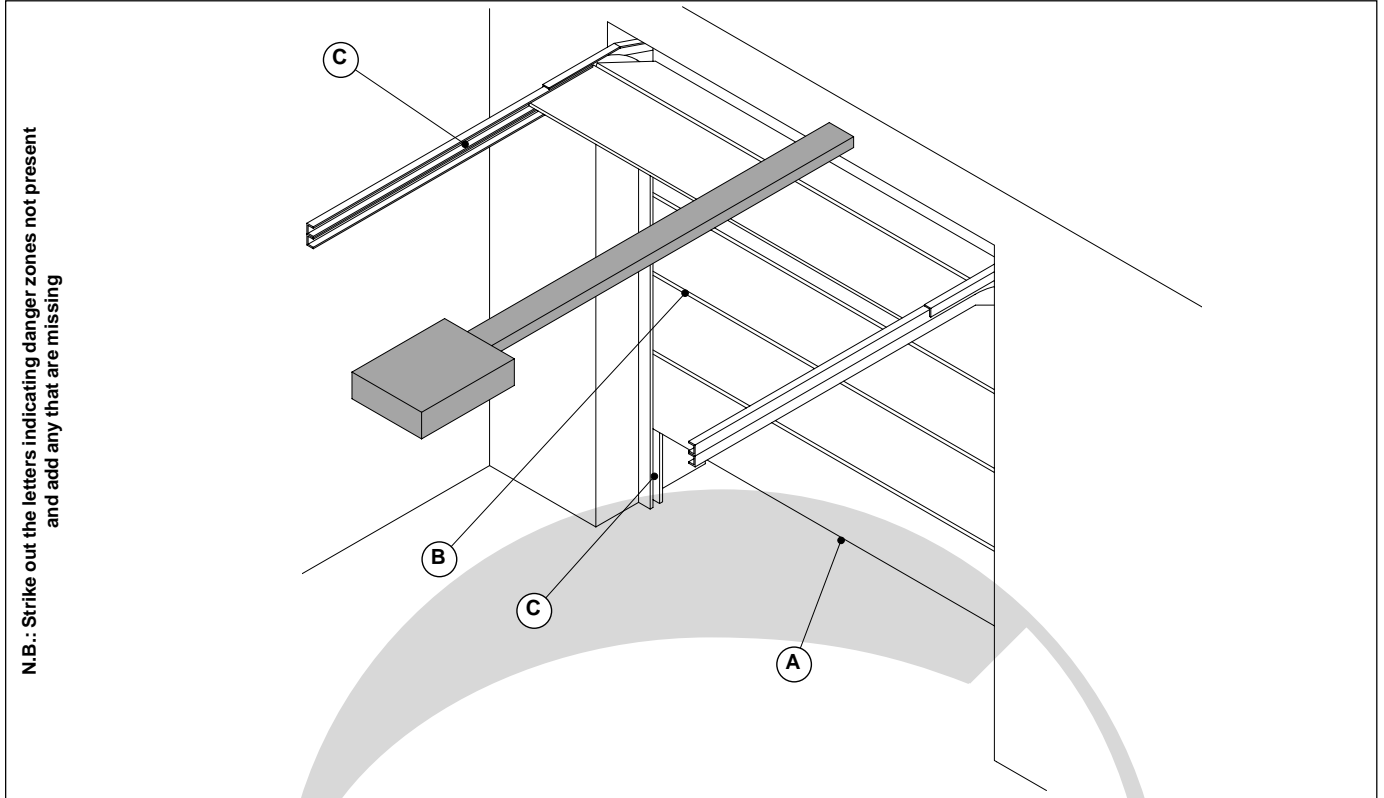

ELECTRICAL CONNECTION DIAGRAM - Fig. 2/D

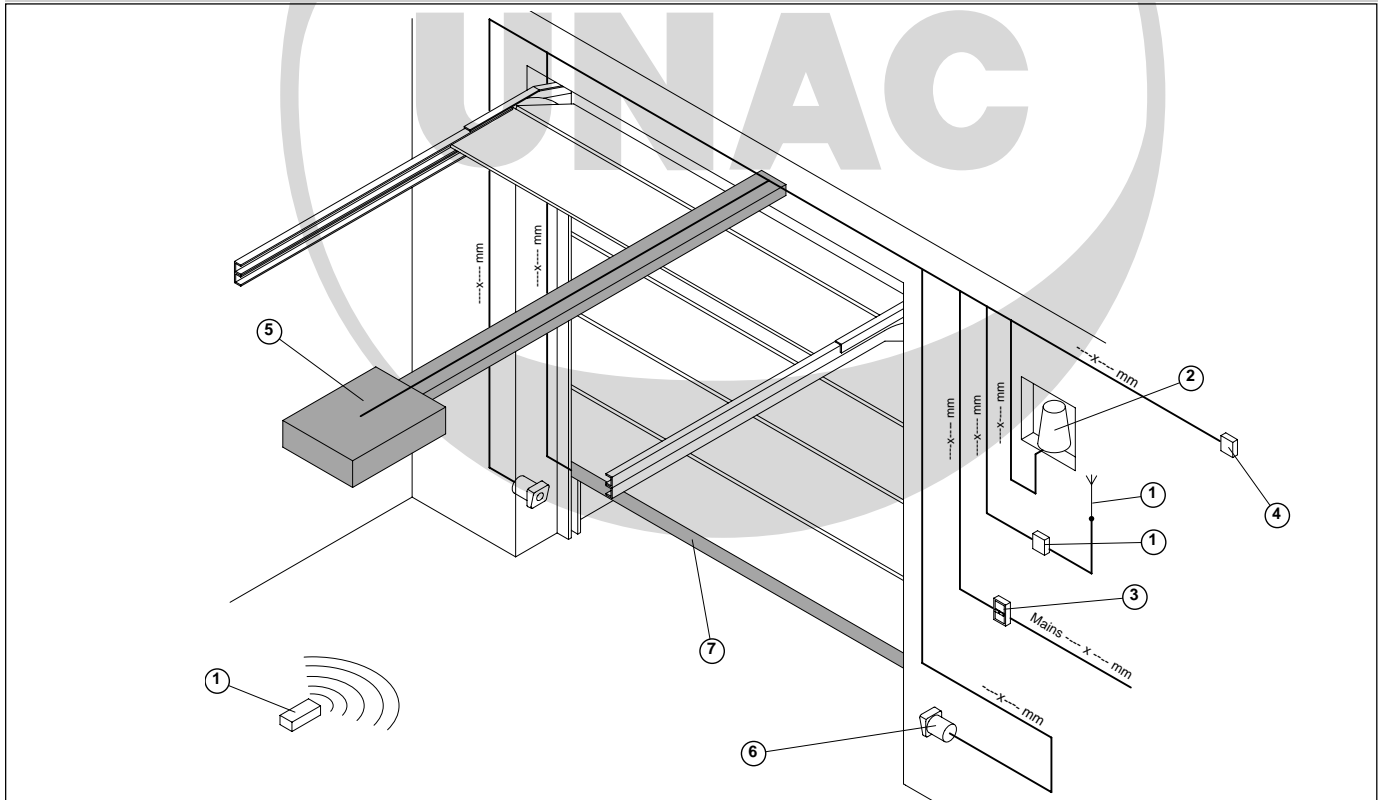

LIST OF INSTALLED COMPONENTS (with ref. to Fig. D) - Table 2

Ref. No.	Description of component	Model / Notes
1	Radio receiver / antenna	
2	Flashing light	
3	Switch / circuit-breaker	
4	Selector / pushbutton	
5	Operator	
6	Photocells	
7	Safety edge	
8		
9		
10		

ASSEMBLY DRAWING OF DOOR (DANGER ZONES) - Figure 1/E

N.B.: Strike out the letters indicating danger zones not present and add any that are missing

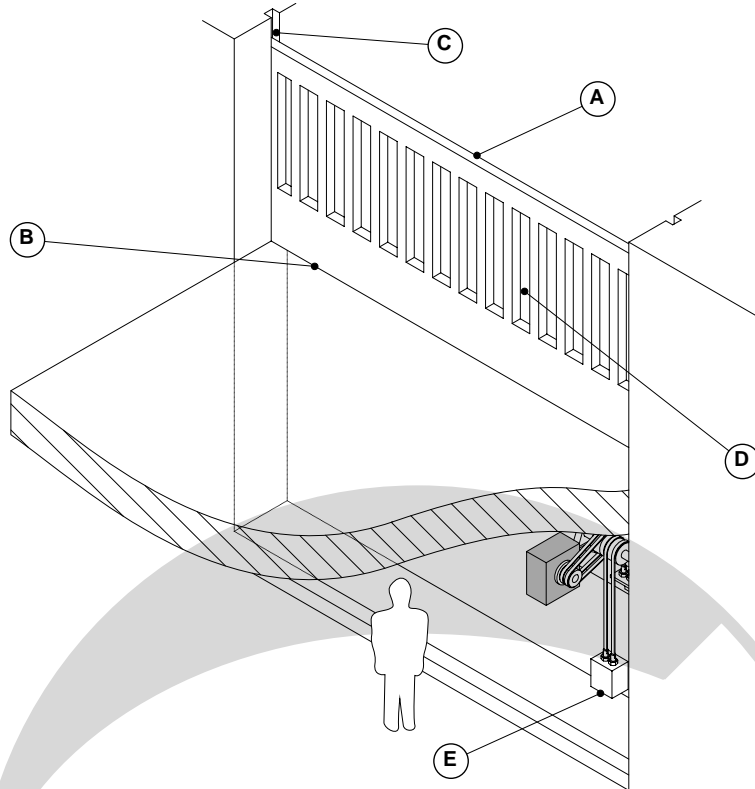

ELECTRICAL CONNECTION DIAGRAM - Fig. 2/E

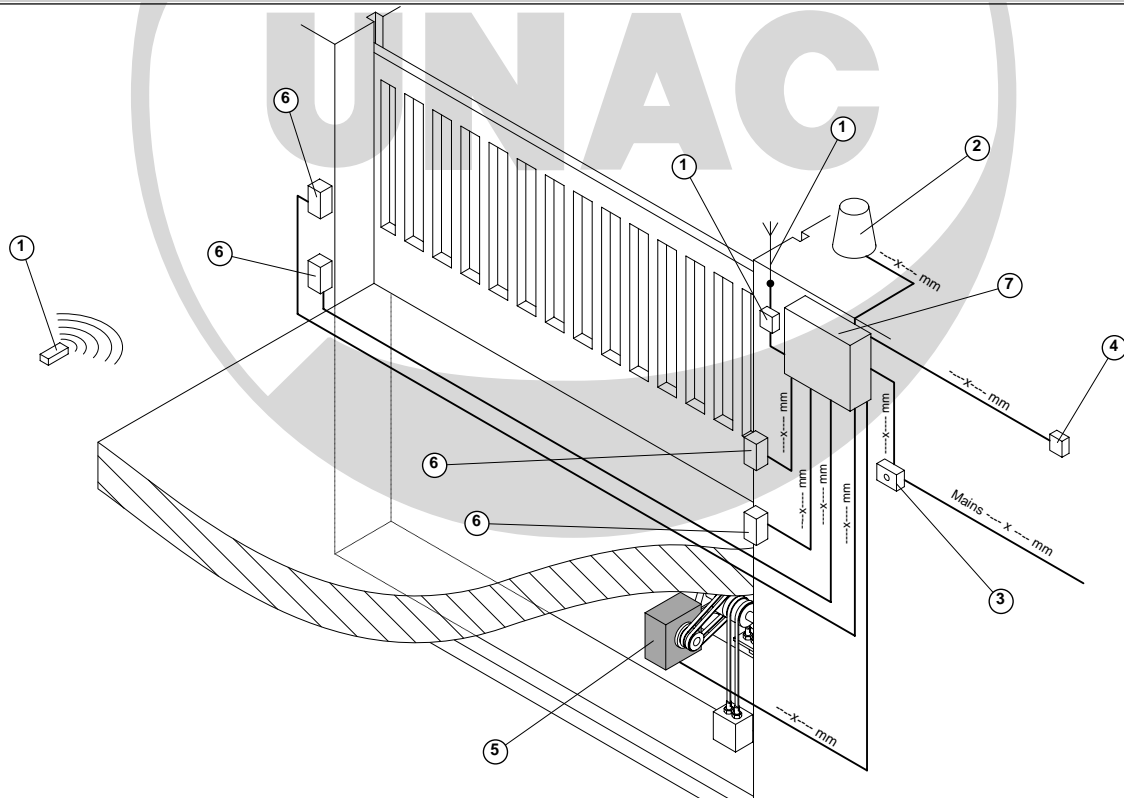

LIST OF INSTALLED COMPONENTS (with ref. to Fig. E) - Table 2

Ref. No.	Description of component	Model / Notes
1	Radio receiver / antenna	
2	Flashing light	
3	Switch / circuit-breaker	
4	Selector / pushbutton	
5	Operator	
6	Photocells	
7	Control panel	
8		
9		
10		

ASSEMBLY DRAWING OF DOOR (DANGER ZONES) - Figure 1/F

N.B.: Strike out the letters indicating danger zones not present and add any that are missing

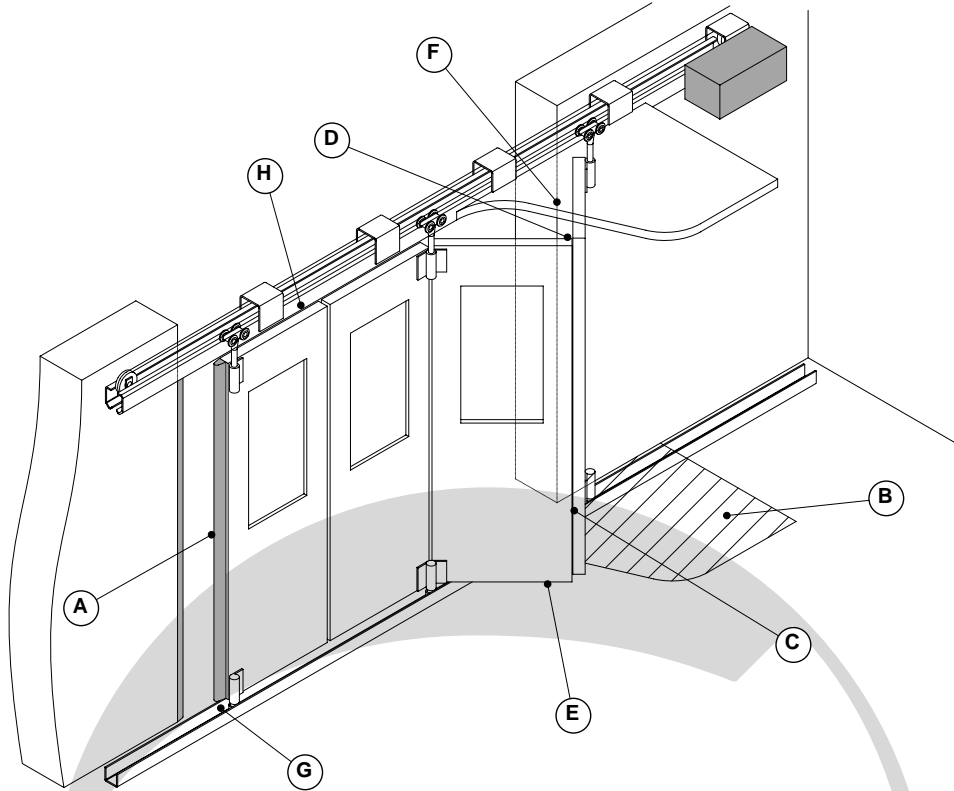

ELECTRICAL CONNECTION DIAGRAM - Fig. 2/F

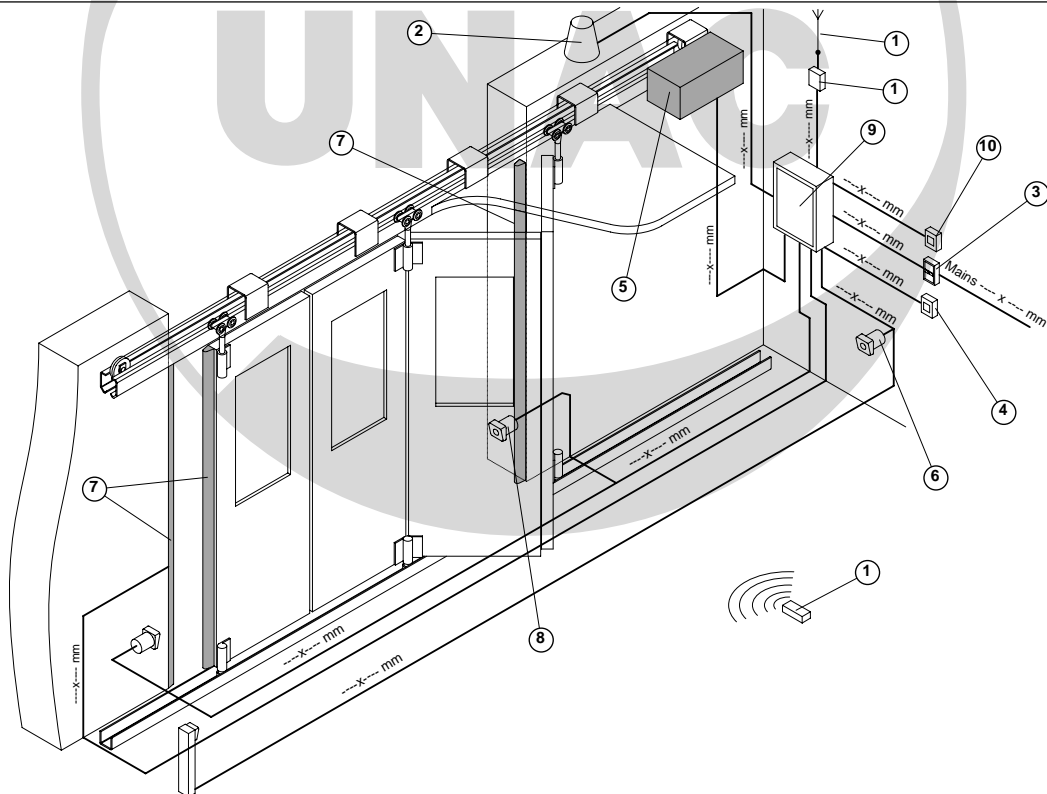

LIST OF INSTALLED COMPONENTS (with ref. to Fig. F) - Table 2

Ref. No.	Description of component	Model / Notes
1	Radio receiver / antenna	
2	Flashing light	
3	Switch / circuit-breaker	
4	Selector / pushbutton	
5	Operator	
6	Pair of internal photocells	
7	Safety edge	
8	Pair of external photocells	
9	Control panel	
10	Emergency stop	

ASSEMBLY DRAWING OF DOOR (DANGER ZONES) - Figure 1/G

N.B.: Strike out the letters indicating danger zones not present and add any that are missing

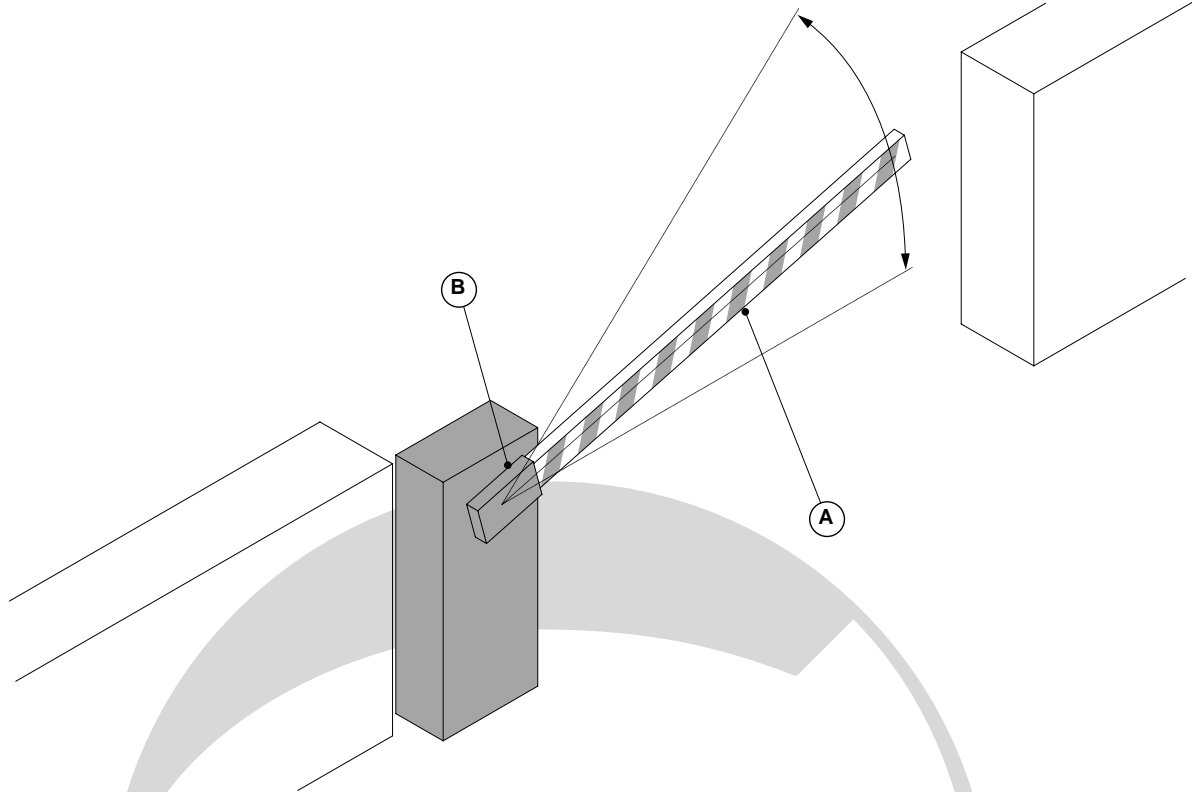

ELECTRICAL CONNECTION DIAGRAM - Fig. 2/G

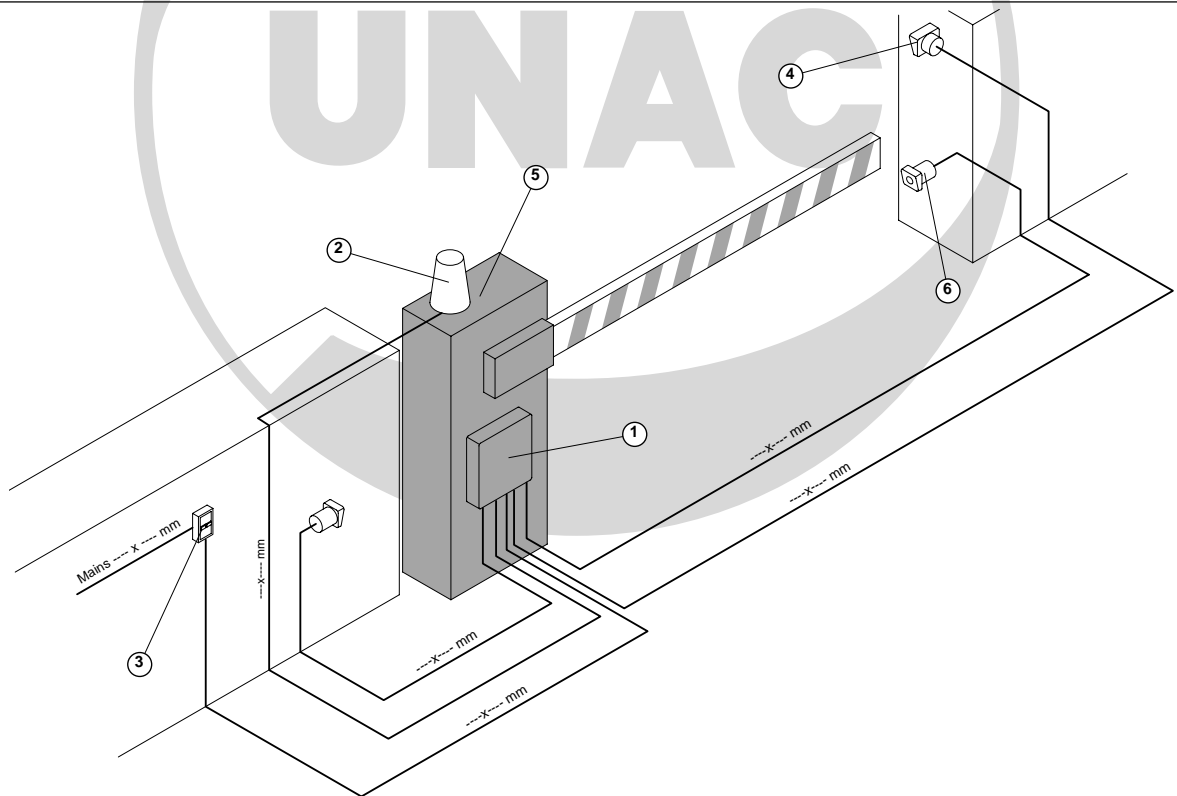

LIST OF INSTALLED COMPONENTS (with ref. to Fig. G) - Table 2

Ref. No.	Description of component	Model / Notes
1	Control panel	
2	Flashing light	
3	Switch / circuit-breaker	
4	Selector / pushbutton	
5	Operator	
6	Photocells	
7		
8		
9		
10		

ASSEMBLY DRAWING OF DOOR (DANGER ZONES) - Figure 1/H

N.B.: Strike out the letters indicating danger zones not present and add any that are missing

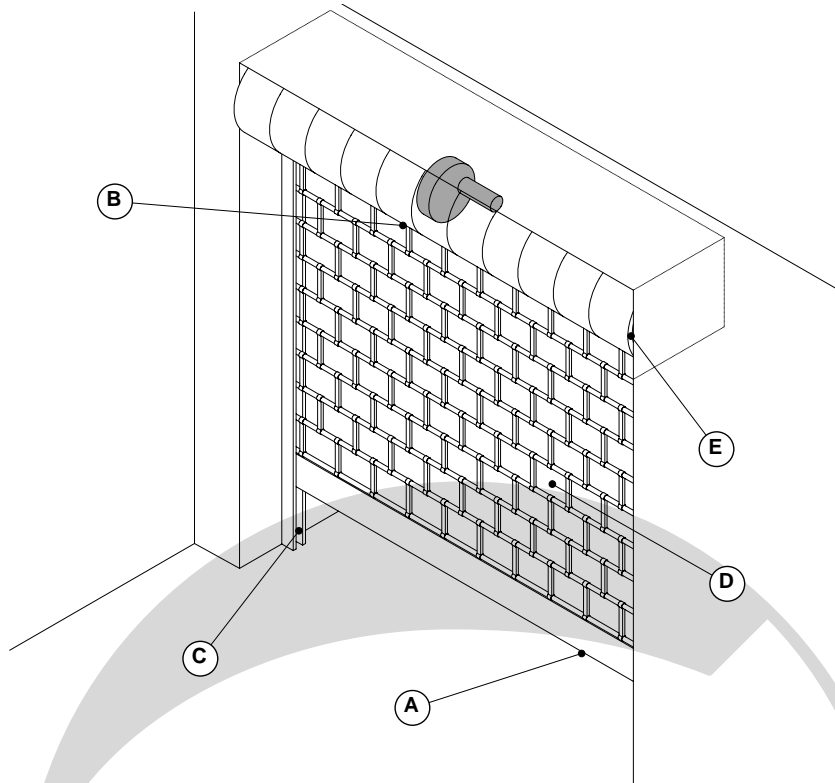

ELECTRICAL CONNECTION DIAGRAM - Fig. 2/H

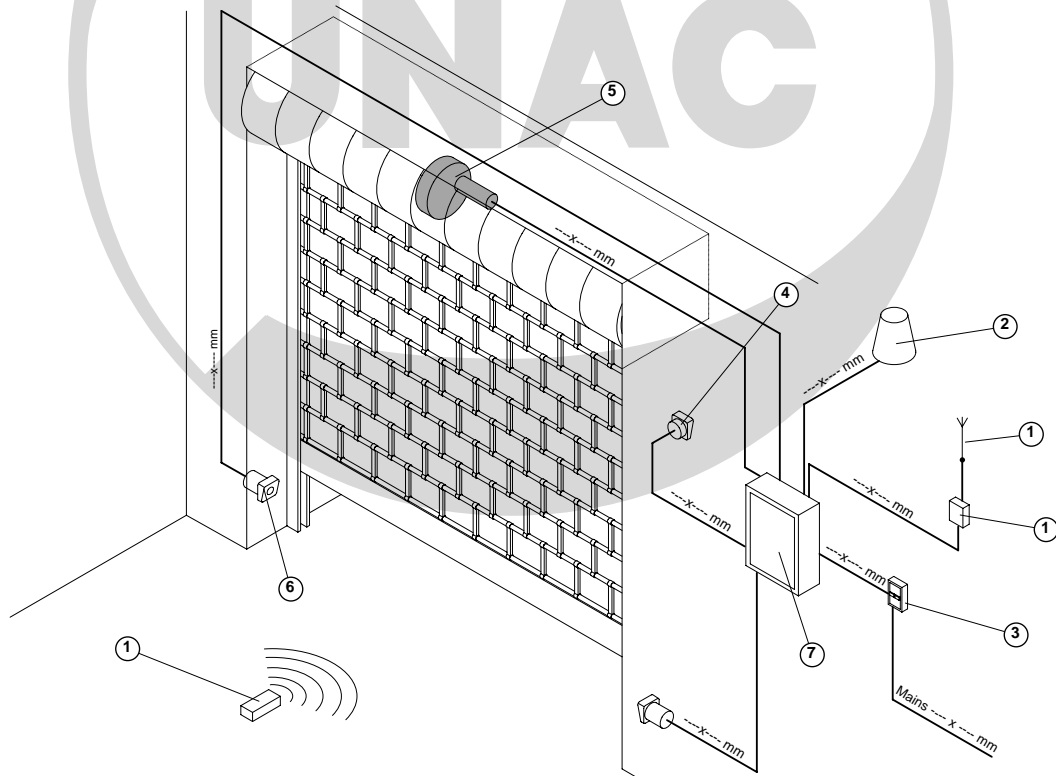

LIST OF INSTALLED COMPONENTS (with ref. to Fig. H) - Table 2

Ref. No.	Description of component	Model / Notes
1	Radio receiver / antenna	
2	Flashing light	
3	Switch / circuit-breaker	
4	Selector / pushbutton	
5	Operator	
6	Photocells	
7	Control panel	
8		
9		
10		

ASSEMBLY DRAWING OF DOOR (DANGER ZONES) - Figure 1/I

N.B.: Strike out the letters indicating danger zones not present and add any that are missing

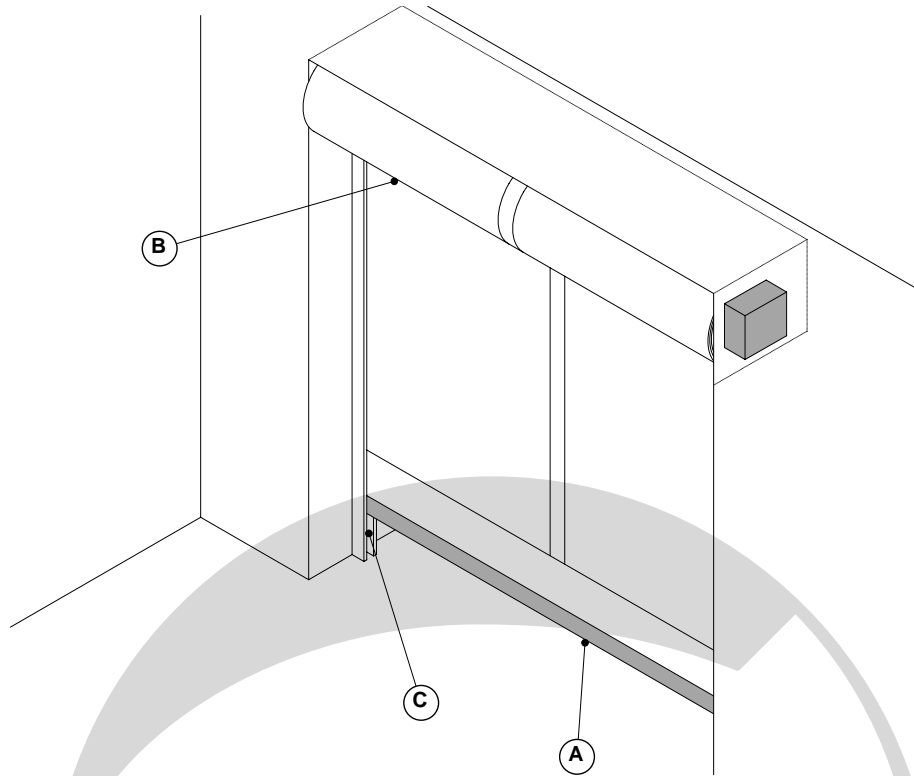

ELECTRICAL CONNECTION DIAGRAM - Fig. 2/I

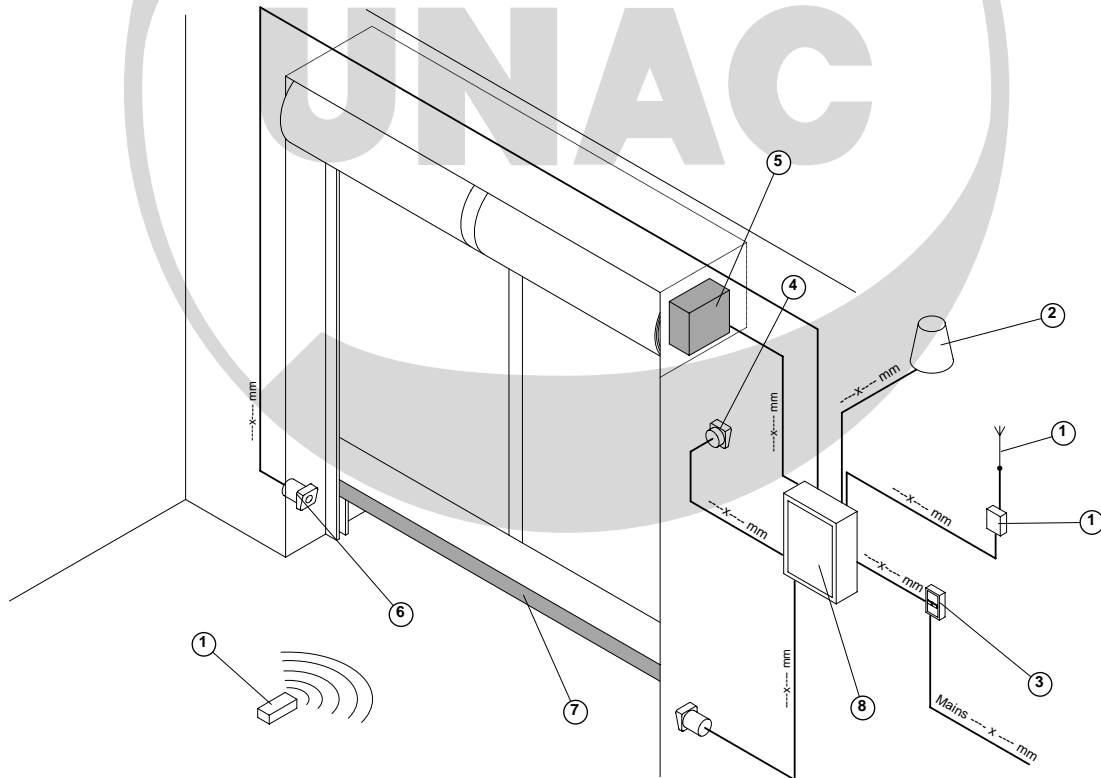

LIST OF INSTALLED COMPONENTS (with ref. to Fig. 1) - Table 2

Ref. No.	Description of component	Model / Notes
1	Radio receiver / antenna	
2	Flashing light	
3	Switch / circuit-breaker	
4	Selector / pushbutton	
5	Operator	
6	Photocells	
7	Safety edge	
8	Control panel	
9		
10		

ASSEMBLY DRAWING OF DOOR (DANGER ZONES) - Figure 1/L

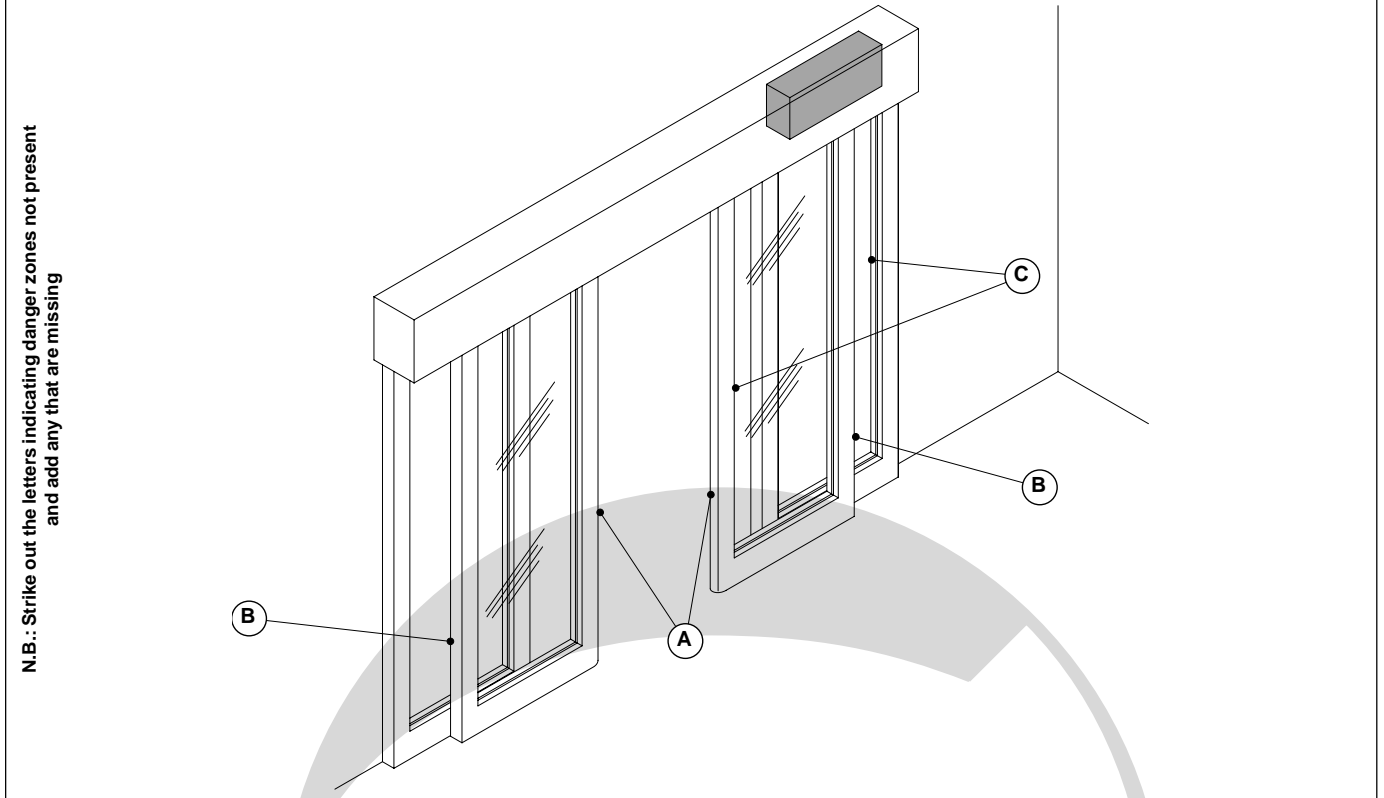

ELECTRICAL CONNECTION DIAGRAM - Fig. 2/L

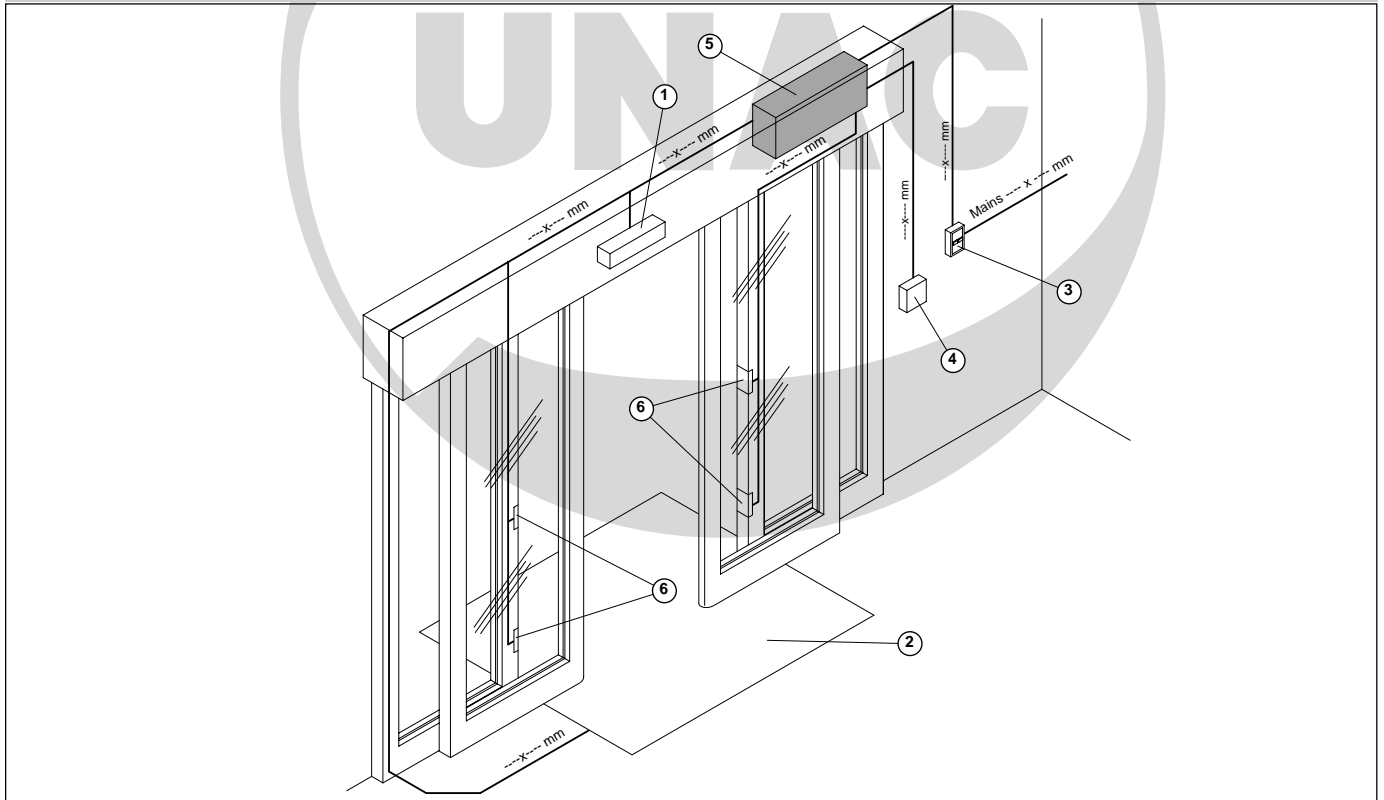

LIST OF INSTALLED COMPONENTS (with ref. to Fig. L) - Table 2

Ref. No.	Description of component	Model / Notes
1	Radar	
2	Pressure-sensitive mat	
3	Switch / circuit-breaker	
4	Selector / pushbutton	
5	Operator	
6	Photocells	
7		
8		
9		
10		

ASSEMBLY DRAWING OF DOOR (DANGER ZONES) - Figure 1/M

N.B.: Strike out the letters indicating danger zones not present and add any that are missing

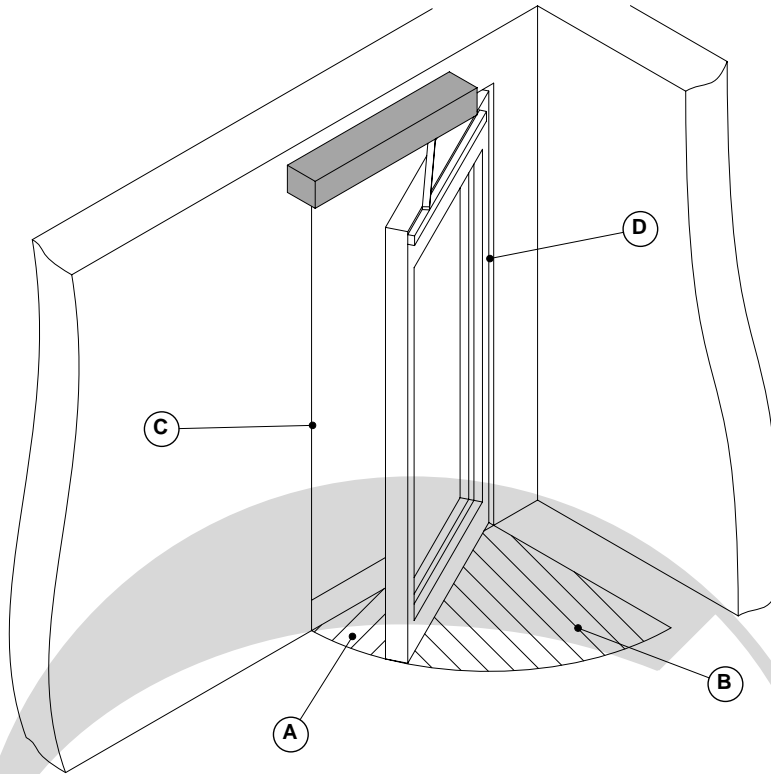

ELECTRICAL CONNECTION DIAGRAM - Fig. 2/M

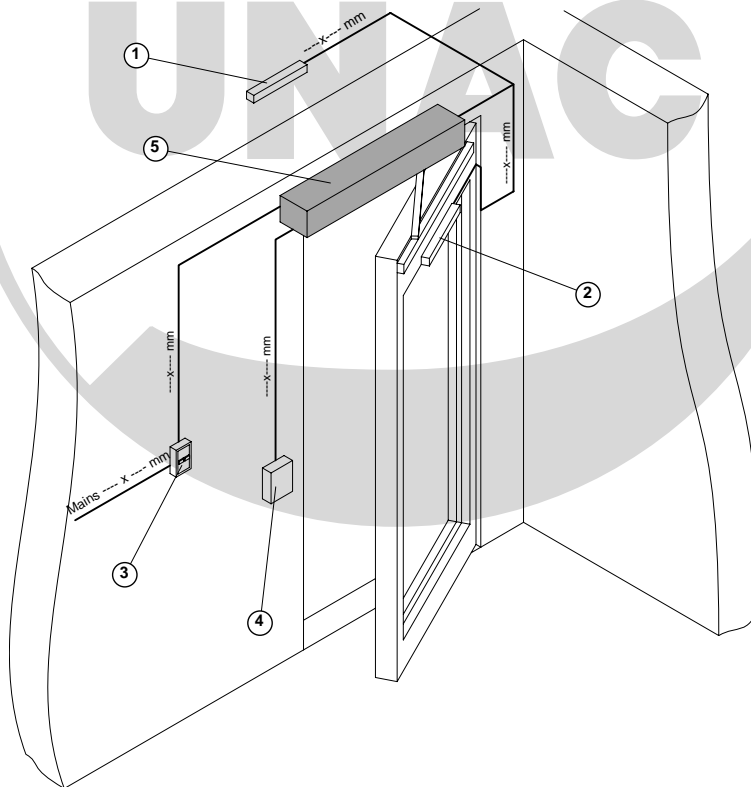

LIST OF INSTALLED COMPONENTS (with ref. to Fig. M) - Table 2

Ref. No.	Description of component	Model / Notes
1	Radar	
2	Loop detector	
3	Switch / circuit-breaker	
4	Selector / pushbutton	
5	Operator	
6		
7		
8		
9		
10		

ASSEMBLY DRAWING OF DOOR (DANGER ZONES) - Figure 1/N

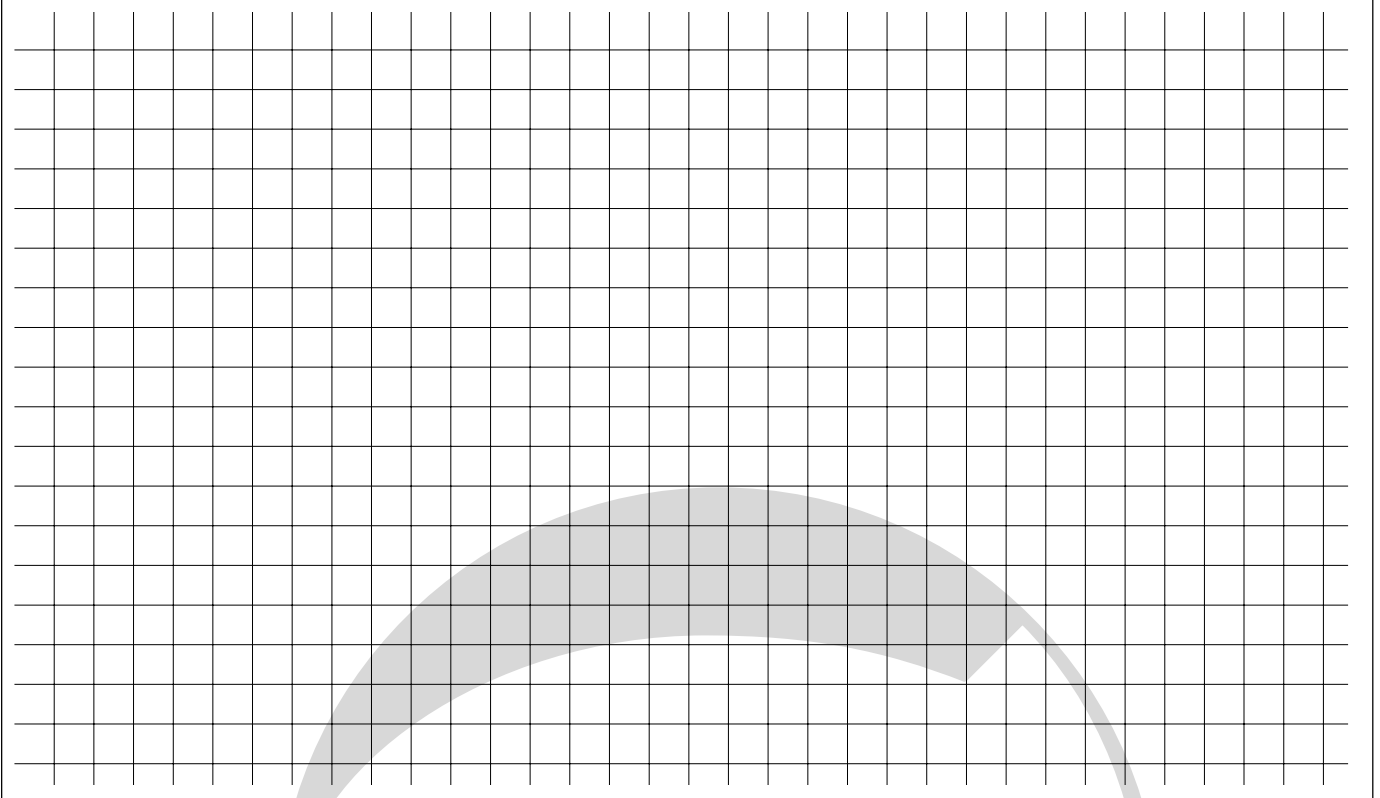

ELECTRICAL CONNECTION DIAGRAM - Fig. 2/N

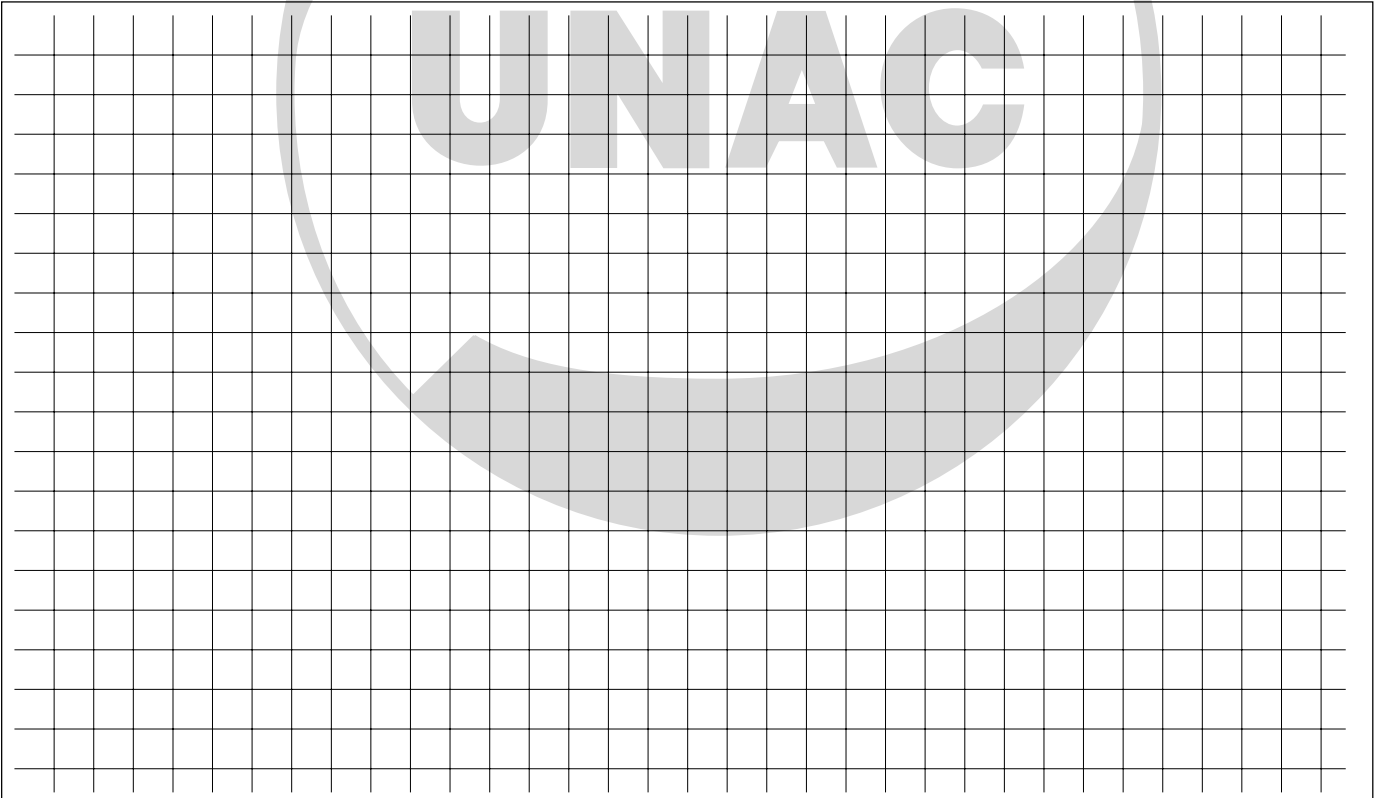

LIST OF INSTALLED COMPONENTS (with ref. to Fig. N) - Table 2

Ref. No.	Description of component	Model / Notes
1		
2		
3		
4		
5		
6		
7		
8		
9		
10		