

EC DECLARATION OF CONFORMITY

Manufacturer : FAAC S.p.A.

Address: Via Benini, 1 - 40069 Zola Predosa BOLOGNA - ITALY

Declares that: 844 T control board,

- conforms to the essential safety requirements of the following directives:
73/23/EEC and subsequent amendment 93/68/EEC.
89/336/EEC and subsequent amendment 92/31/EEC and 93/68/EEC

Additional note:

This product underwent tests in a typical uniform configuration
(all products manufactured by FAAC S.p.A.).

Bologna, 01 January 2005

The Managing Director
A. Bassi

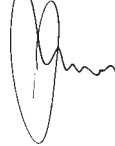

WARNINGS FOR THE INSTALLER GENERAL SAFETY OBLIGATIONS

- 1) **ATTENTION! To ensure the safety of people, it is important that you read all the following instructions. Incorrect installation or incorrect use of the product could cause serious harm to people.**
- 2) Carefully read the instructions before beginning to install the product.
- 3) Do not leave packing materials (plastic, polystyrene, etc.) within reach of children as such materials are potential sources of danger.
- 4) Store these instructions for future reference.
- 5) This product was designed and built strictly for the use indicated in this documentation. Any other use, not expressly indicated here, could compromise the good condition/operation of the product and/or be a source of danger.
- 6) FAAC declines all liability caused by improper use or use other than that for which the automated system was intended.
- 7) Do not install the equipment in an explosive atmosphere: the presence of inflammable gas or fumes is a serious danger to safety.
- 8) The mechanical parts must conform to the provisions of Standards EN 12604 and EN 12605.
For non-EU countries, to obtain an adequate level of safety, the Standards mentioned above must be observed, in addition to national legal regulations.
- 9) FAAC is not responsible for failure to observe Good Technique in the construction of the closing elements to be motorised, or for any deformation that may occur during use.
- 10) The installation must conform to Standards EN 12453 and EN 12445.
For non-EU countries, to obtain an adequate level of safety, the Standards mentioned above must be observed, in addition to national legal regulations.
- 11) Before attempting any job on the system, cut out electrical power.
- 12) The mains power supply of the automated system must be fitted with an all-pole switch with contact opening distance of 3mm or greater. Use of a 6A thermal breaker with all-pole circuit break is recommended.
- 13) Make sure that a differential switch with threshold of 0.03 A is fitted upstream of the system.
- 14) Make sure that the earthing system is perfectly constructed, and connect metal parts of the means of the closure to it.
- 15) The safety devices (EN 12978 standard) protect any danger areas against **mechanical movement Risks**, such as crushing, dragging, and shearing.
- 16) Use of at least one indicator-light (e.g. FAACLIGHT) is recommended for every system, as well as a warning sign adequately secured to the frame structure, in addition to the devices mentioned at point * 15".
- 17) FAAC declines all liability as concerns safety and efficient operation of the automated system, if system components not produced by FAAC are used.
- 18) For maintenance, strictly use original parts by FAAC.
- 19) Do not in any way modify the components of the automated system.
- 20) The installer shall supply all information concerning manual operation of the system in case of an emergency, and shall hand over to the user the warnings handbook supplied with the product.
- 21) Do not allow children or adults to stay near the product while it is operating.
- 22) Keep remote controls or other pulse generators away from children, to prevent the automated system from being activated involuntarily.
- 23) Transit through the leaves is allowed only when the gate is fully open.
- 24) The user must not attempt any kind of repair or direct action whatever and contact qualified personnel only.
- 25) Maintenance: check at least every 6 months the efficiency of the system, particularly the efficiency of the safety devices (including, where foreseen, the operator thrust force) and of the release devices.
- 26) **Anything not expressly specified in these instructions is not permitted.**

CONTROL BOARD 844 T

These instructions apply to the following model:

844T Electronic control unit

This appliance can be installed in containers mod. E, L and LM. Before securing the card in the container, fit the supplied support feet (long for mod. E, short for models L and LM) in the 3S-holes (Fig. 1).

1. TECHNICAL SPECIFICATIONS

| | |
|----------------------------|---|
| Power supply | 230 Vac. 3ph (+6% -10% 50 Hz.) 400 Vac. 3ph + N (+6% -10% 50 Hz.) |
| Motor max load | 1,3 Kw. |
| Accessories power supply | 24 Vdc. |
| Accessories max load | 500 mA. |
| Warning light power supply | 24 Vac. (max 5 Watt.) |
| Temperature range | -20 °C + 55 °C |
| Fuses | F2, F5, F6, F7 (Tab. 1) |
| Quick-fit plugs | decoding cards or RP receivers |
| Inputs | OPEN/PARTIAL OPEN/ STOP/CLOSURE SAFETY DEVICE/ LIMIT-SENSORS |
| Outputs | warning light flashlight motor power supply to 24 Vdc. accessories pause time (5 - 10 - 15 - 30 - 60 120 - 180 sec.) |
| Programming | logics A1/A2/S1/S2/E1/E2/B/C pre-flashing |
| Motor braking | fixed |
| Safety timing | 255 sec. |

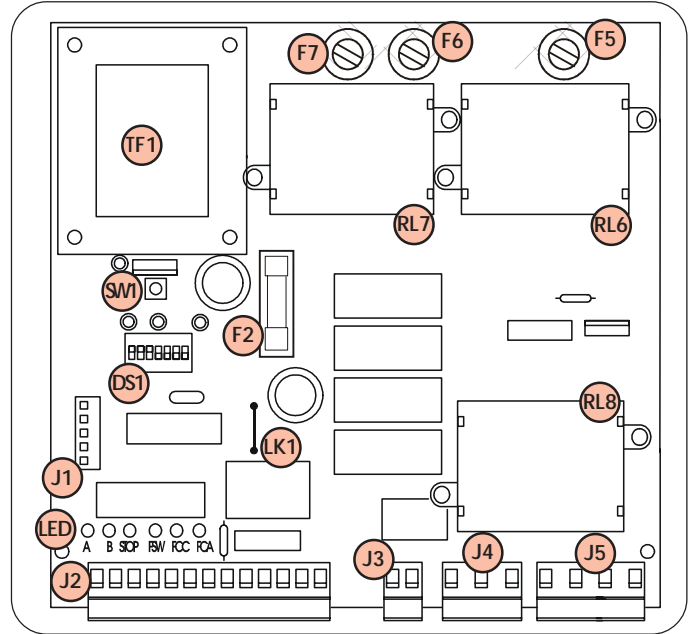

Tab. 1 - 844 T CONTROL UNIT COMPONENTS

| | |
|--------------|--|
| F5 - F6 - F7 | Fuse F1 6,3x32 5A/250V rapid (power supply fuses) |
| F2 | Fuse F2 5x20 1,6A/250V rapid (accessories) |
| SW1 | RESET push-button |
| DS1 | Programming micrositches |
| LED | Input status signalling LEDs A, B, STOP, FSW, FCC, FCA |
| J1 | Quick-fit plug for decoding cards/RP receivers |
| J2 | Low voltage terminal board for inputs/accessories |
| J3 | Flashlight output terminal board (230V~ max 60W) |
| J4 | Motor output terminal board |
| J5 | Line power supply input terminal board |
| LK1 | Bridge for warning light free contact |
| RL6 - RL7 | Motor relay |
| RL8 | Braking relay |

2. ELECTRICAL CONNECTIONS WITH 400V 3ph (N.B.: for connection to 230 V 3ph, see Chapter 8)

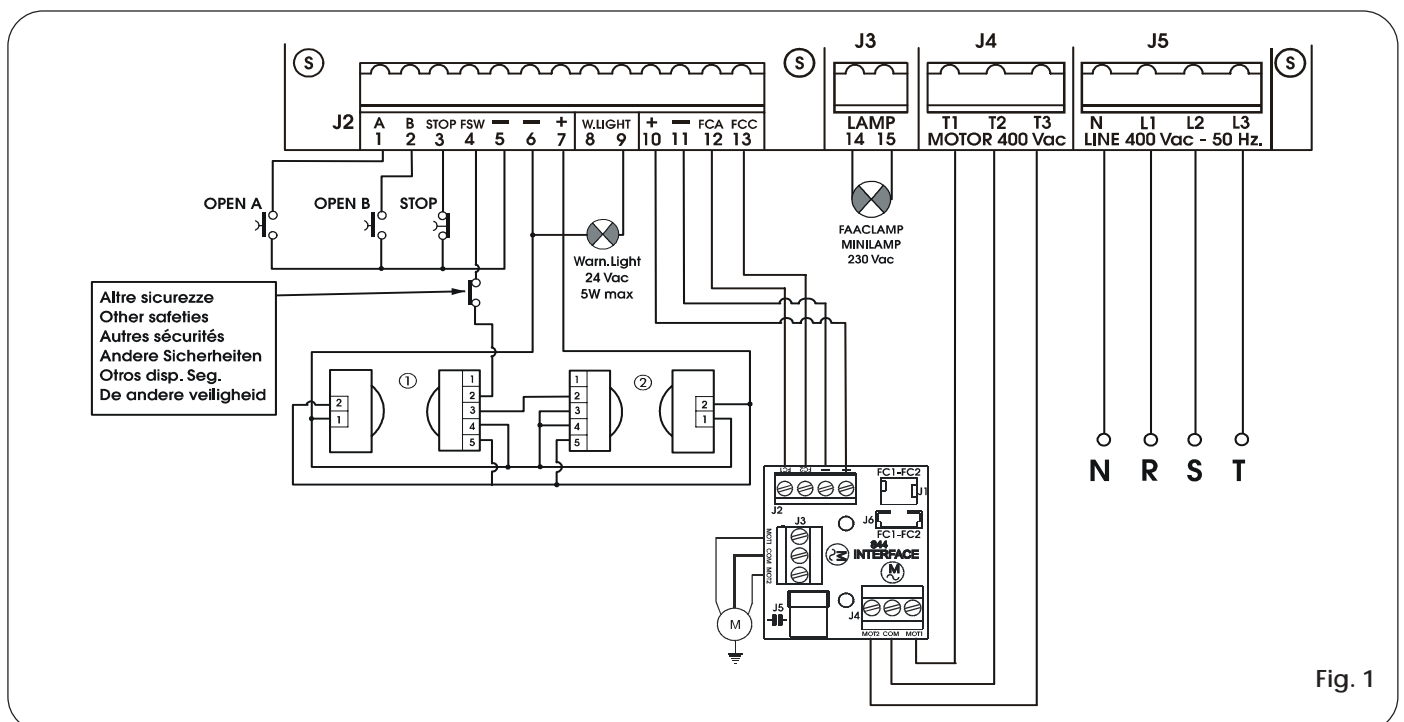
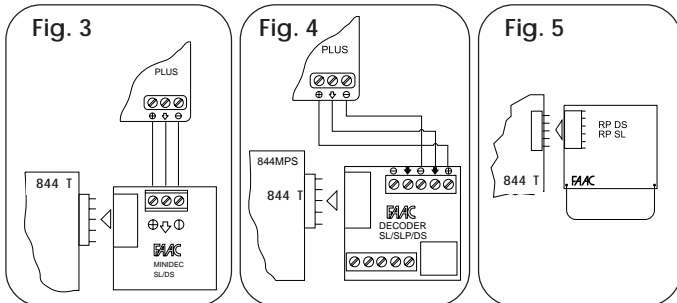

Fig. 1

3. DESCRIPTION

3.1. J1 PLUG

The J1 plug is used for rapid connection of cards MINIDEC, DECODER, RP RECEIVERS (Fig. 3, 4, 5)
Install by fitting the accessory cards so that their components side faces the inside of the 844 T electronic appliance.
Insert and remove the cards after cutting power.



9 = Warning light output (24 Vac)

The maximum load of the warning light is 5 W.
For instructions on operation of the warning light, consult microswitch programming.

➔ If you cut out jumper LK1, you obtain a voltage free contact between terminals 8 and 9 (see Fig. 6).

10 = 24 Vdc (+) power supply for inductive limit switch

11 = Limit switch common contact

12 = Opening limit switch (N.C.)

13 = Closing limit switch (N.C.)

3.3. TERMINAL BOARD J3 (high voltage)

Terminal board for connecting flashlight (max 60W).

3.4. TERMINAL BOARD J4 (high voltage)

Terminal board for connection of motor.

3.5. TERMINAL BOARD J5 (high voltage)

Terminal board for supplying power of 400V 3ph + Neutral - 50 Hz (see Fig. 1) or 230V 3ph - 50 Hz (see Fig. 8).

Connect the yellow-green earth cable as shown in Fig. 7.

3.2. TERMINAL BOARD J2 (low voltage)

1 = OPEN A (N.O.) – Total opening

This is any pulse generator with N.O. contact which, when activated, produces a gate opening movement. In A, E and S logics, it commands both opening and closing.
To install several Open A devices, connect N.O. contacts in parallel.

2 = OPEN B (N.O.) – Opening for pedestrians / Closing

This is any pulse generator with N.O. contact which, when activated in logics A, E and S, produces a gate opening movement for pedestrians. In B and C logics, it commands a closing movement.
To install several Open B devices, connect N.O. contacts in parallel.

3 = STOP command (N.C.)

This is any device (e.g. a push-button) which, by opening a contact, stops gate movement.
To install several stop devices, connect the N.C. contacts in series.

➔ If stop devices are not connected, link the input to the common contact (terminal 5) via a jumper.

4 = FSW closing safety devices contact (N.C.)

Safety devices are all devices (photocells, sensitive edges, magnetic coils) with N.C. contact, which, if there is an obstacle in the area they protect, operate to interrupt gate movement. The purpose of the closing safety devices is to protect the gate movement area during closing.
If the safety devices are tripped during closure, gate movement is reversed, whereas they have no effect during opening. If used when the gate is open or pausing, closing safety devices prevent its closing.
To install several safety devices, connect the N.C. contacts in series.

➔ If closing safety devices are not connected, link this input to the common contact (terminal 5) via a jumper.

5 = Common contact for commands

6 = Negative of accessories power supply

7 = 24 Vdc (+) power supply for accessories

Max load of accessories is 500 mA.
To calculate absorption values, refer to the instructions for individual accessories.

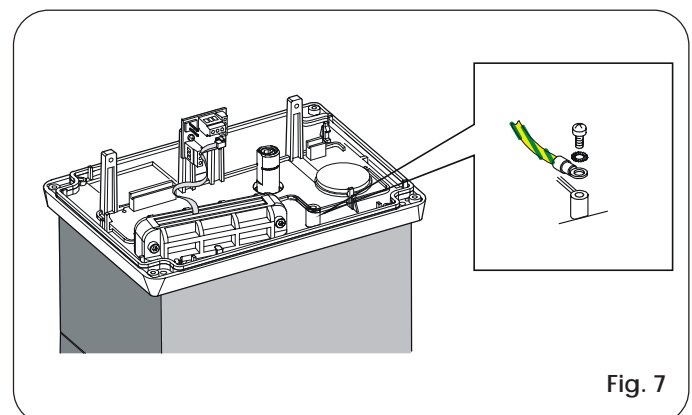
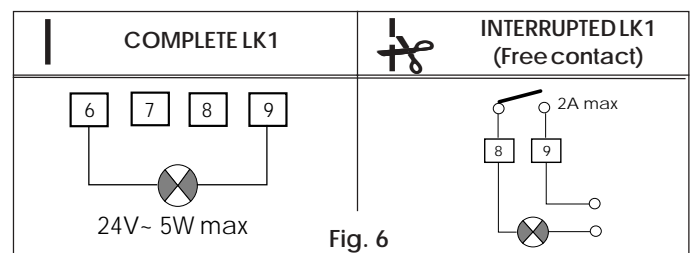

3.6. SIGNALLING LEDs

6 LEDs are fitted on the card, indicating status of terminal board inputs:

LED LIGHTED = contact closed
LED OFF = contact open

Tab. 2 - STATUS OF LEDs

| LED | LIGHTED | OFF |
|---------------|-------------------------------------|-------------------------------------|
| OPEN A | Command active | Command inactive |
| OPEN B | Command active | Command inactive |
| STOP | Command inactive | Command active |
| FSW | Safety devices not operating | Safety devices operating |
| FCC | Closing limit sensor free | Closing limit sensor engaged |
| FCA | Opening limit sensor free | Opening limit sensor engaged |

NB.: The status of the LEDs while the gate is closed at rest are shown in bold.

4. PROGRAMMING

To program operation of automation, use the microswitches as shown below.

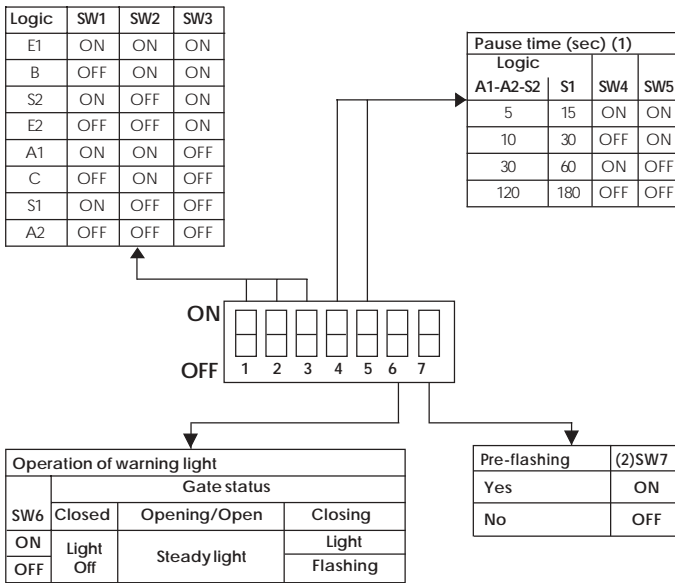

(1) Pause times include pre-flashing if any
(2) Pre-flashing begins 5" before every movement.

➡ You must press the RESET push-button after every programming job.

4.1. FUNCTION LOGICS

The following are available:

A1/A2 = "Automatic" S1/S2 = "Safety"
E1/E2/B = "Semi-automatic" C = "Dead man"

Operation of automation in the different logics is indicated in Tables 3 - 4 - 5 - 6 - 7 - 8 - 9 - 10.

4.2. PAUSE TIME

Pause time is waiting time in open position before re-closing when an automatic logic was selected.

Pause times include pre-flashing if any

4.3. OPERATION OF WARNING LIGHT

Used to change the appearance of the warning light at closing by making it flash.

4.4. PRE-FLASHING

Flashlight pre-flashing time of 5 sec before any movement can be selected. This warns anyone near the gate that it is about to move.

5. FAULT CONDITIONS

The following conditions cause certain effects to normal operation of automation:

- ① microprocessor error
- ② safety electronic timing tripped (operation is interrupted if continuous work time exceeds 255 sec.).
- ③ limit sensors disconnected (or both engaged)
 - Conditions ① and ② cause automation to stop and nothing more.
 - Condition ③ causes an alarm situation disabling any activity:
 - Normal operation can be restored only after eliminating the alarm cause and pressing the RESET push-button (or turning off power supply momentarily).
 - To have this condition signalled, the warning light must be connected: the alarm is signalled by very rapidly flashing light (0.25 sec).

6. LIMIT SENSORS CONNECTION CHECK

- 1) Manually take the gate toward opening position, and check if, with the leaf open, the FCC LED is lighted and the FCA LED is off.
- 2) Manually take the gate toward closing position, and check if, with the leaf closed, the FCA LED is lighted and the FCC LED is off.
- 2) If the LEDs are inverted, changeover the cables connected to terminals 12 and 13.

7. ROTATION DIRECTION CHECK

- 1) Release the operator, take it manually to mid-travel and re-lock it.
- 2) Power up the system and then press the RESET push-button.
- 3) Give an Open command to the operator, check if the gate moves in opening direction and then press the RESET push-button to stop the leaf moving.
- 4) If rotation direction is incorrect, change over wiring of cables T1 and T3 of the electric motor.

8. ELECTRICAL CONNECTIONS WITH 230V 3ph

To connect the 844 T appliance to a 3-phase 230 V mains, observe the diagram in Fig. 8.

N.B.: The electric motor of the gearmotor must be 230V 3-phase.

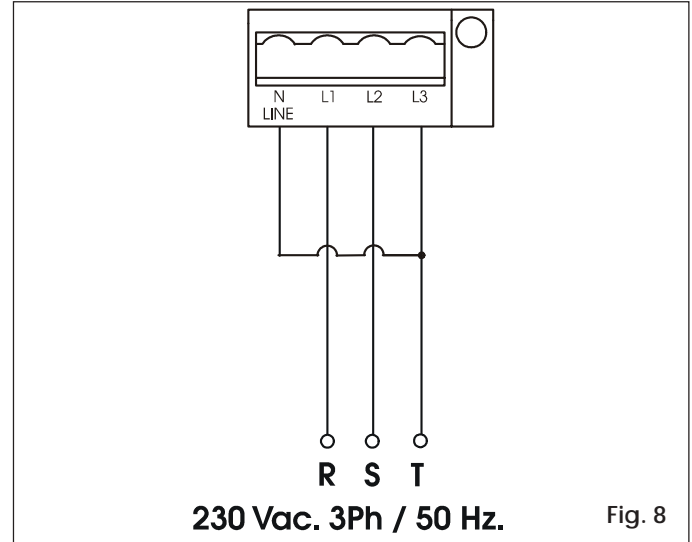

Tab. 3 - LOGIC A1 (AUTOMATIC)

| Logic "A1" | PULSES | | | |
|---------------|---------------------------------------|---------------------|-----------------------------------|----------------|
| | GATES STATUS | OPEN A - OPEN B (1) | STOP | SAFETY DEVICES |
| CLOSED | Opens and closes after pause time (2) | No effect | No effect | No effect |
| OPEN ON PAUSE | Re-closes after 5" (3) | Stops the count | Freezes pause until disengagement | |
| CLOSING | Reverses motion | Stops | Reverses motion | |
| OPENING | No effect | Stops | No effect | |
| STOPPED | Re-closes (2) | No effect | No effect | |

Tab. 7 - LOGIC E1 (SEMI-AUTOMATIC)

| Logic "E1" | PULSES | | | |
|------------|--|---------------------|-----------------|----------------|
| | GATES STATUS | OPEN A - OPEN B (1) | STOP | SAFETY DEVICES |
| CLOSED | Opens (2) | No effect | No effect | No effect |
| OPEN | Re-closes (2) | No effect | No effect | No effect |
| CLOSING | Reverses motion | Stops | Reverses motion | |
| OPENING | Stops | Stops | No effect | |
| STOPPED | re-closes (when safety devices engaged, it re-opens) (2) | No effect | No effect | No effect |

Tab. 4 - LOGIC A2 (AUTOMATIC PLUS)

| Logic "A2" | PULSES | | | |
|---------------|---------------------------------------|---------------------|---|----------------|
| | GATES STATUS | OPEN A - OPEN B (1) | STOP | SAFETY DEVICES |
| CLOSED | Opens and closes after pause time (2) | No effect | No effect | No effect |
| OPEN ON PAUSE | Re-closes after 5" (3) | Stops the count | When disengaged, re-closes after 5" | |
| CLOSING | Reverses motion | Stops | Stops and reverses at disengagement (2) | |
| OPENING | No effect | Stops | No effect | |
| STOPPED | Re-closes (2) | No effect | No effect | |

Tab. 8 - LOGIC E2 (SEMI-AUTOMATIC PLUS)

| Logic "E2" | PULSES | | | |
|------------|--|---------------------|---|----------------|
| | GATES STATUS | OPEN A - OPEN B (1) | STOP | SAFETY DEVICES |
| CLOSED | Opens (2) | No effect | No effect | No effect |
| OPEN | Re-closes (2) | No effect | No effect | No effect |
| CLOSING | Reverses motion | Stops | Stops and reverses at disengagement (2) | |
| OPENING | Stops | Stops | No effect | |
| STOPPED | Re-closes (when safety devices engaged, it re-opens) (2) | No effect | No effect | No effect |

Tab. 5 - LOGIC S1 (SAFETY)

| Logic "S1" | PULSES | | | |
|---------------|---------------------------------------|---------------------|-------------------------------------|----------------|
| | GATES STATUS | OPEN A - OPEN B (1) | STOP | SAFETY DEVICES |
| CLOSED | Opens and closes after pause time (2) | No effect | No effect | No effect |
| OPEN ON PAUSE | Closes immediately (2-3) | Stops the count | when disengaged, re-closes after 5" | |
| CLOSING | Reverses motion | Stops | Reverses motion | |
| OPENING | Reverses motion | Stops | No effect | |
| STOPPED | Re-closes (2) | No effect | No effect | |

Tab. 9 - LOGIC B (SEMI-AUTOMATIC)

| Logic "B" | PULSES | | | | |
|-----------|-----------------------|-----------------------|----------------|------------------|----------------|
| | GATES STATUS | OPEN A | OPEN B (4) | STOP | SAFETY DEVICES |
| CLOSED | Opens (2) | No effect | No effect | No effect | No effect |
| OPEN | No effect | Closes (2) | No effect | prevents closing | |
| CLOSING | No effect | No effect | Stops movement | Stops movement | |
| OPENING | No effect | No effect | Stops movement | No effect | |
| STOPPED | Completes opening (2) | Completes closing (2) | No effect | prevents closing | |

Tab. 6 - LOGIC S2 (SAFETY PLUS)

| Logic "S2" | PULSES | | | |
|---------------|---------------------------------------|---------------------|---|----------------|
| | GATES STATUS | OPEN A - OPEN B (1) | STOP | SAFETY DEVICES |
| CLOSED | Opens and closes after pause time (2) | No effect | No effect | No effect |
| OPEN ON PAUSE | Closes immediately (2-3) | Stops the count | Freezes pause until disengagement | |
| CLOSING | Reverses motion | Stops | Stops and reverses at disengagement (2) | |
| OPENING | Reverses motion | Stops | No effect | |
| STOPPED | Re-closes (2) | No effect | No effect | |

Tab. 10 - LOGIC C (DEAD MAN)

| Logic "C" | CONTROLS HELD DOWN CONTINUOUSLY | | PULSES | | |
|-----------|---------------------------------|-------------------|------------------|------------------|----------------|
| | GATES STATUS | OPEN A (5) | OPEN B (4 and 5) | STOP | SAFETY DEVICES |
| CLOSED | Opens | No effect | No effect | No effect | No effect |
| OPEN | No effect | Closes | No effect | prevents closing | |
| CLOSING | No effect | / | Stops movement | Stops movement | |
| OPENING | No effect | | No effect | Stops movement | No effect |
| STOPPED | Completes opening | Completes closing | No effect | prevents closing | |

- (1) OPEN B input commands partial opening.
- (2) With pre-flashing selected, movement begins after 5 sec.
- (3) If the pulse is sent during pre-flashing, counting is restarted.
- (4) OPEN B input commands closing.
- (5) Push-button must be kept pressed to activate gate movement. When the push-button is released, the gate stops.