

EC MACHINE DIRECTIVE COMPLIANCE DECLARATION

(DIRECTIVE 89/392 EEC, APPENDIX II, PART B)

Manufacturer: FAAC S.p.A.

Address: Via Benini, 1 - 40069 Zola Predosa BOLOGNA - ITALY

Hereby declares that: the 525/530 automation system

- is intended to be incorporated into machinery, or to be assembled with other machinery to constitute machinery in compliance with the requirements of Directive 89/392 EEC, and subsequent amendments 91/368 EEC, 93/44 EEC and 93/68 EEC;
- complies with the essential safety requirements in the following EEC Directives:
73/23 EEC and subsequent amendment 93/68 EEC.
89/336 EEC and subsequent amendments 92/31 EEC and 93/68 EEC.

and furthermore declares that unit must not be put into service until the machinery into which it is incorporated or of which it is a component has been identified and declared to be in conformity with the provisions of Directive 89/392 EEC and subsequent amendments enacted by the national implementing legislation.

Bologna, 1 January 1999

Managing Director
A. Bassi



IMPORTANT NOTICE FOR THE INSTALLER

GENERAL SAFETY REGULATIONS

- 1) **IMPORTANT! FAAC strongly recommends to follow these instructions carefully for the safety of persons. Improper installation or misuse of the product will cause very serious damages to persons.**
- 2) Read the instructions carefully before installing the product.
- 3) Packaging materials (plastic, polystyrene etc.) are a potential hazard and must be kept out of reach of children.
- 4) Keep these instructions for future reference.
- 5) This product has been designed and manufactured only for the use stated in this manual. Any other use not expressly set forth will affect the reliability of the product and/or could be source of hazard.
- 6) FAAC S.p.A. cannot be held responsible for any damage caused by improper use or different from the use for which the automation system is destined to.
- 7) Do not use this device in areas subject to explosion: the presence of flammable gas or fumes is a serious hazard.
- 8) Mechanical constructive elements must comply with UNI 8612, CEN prEN 12604 and CEN prEN 12605 standards.
Countries outside the EC shall follow the regulations above besides their national normative references in order to offer the utmost safety.
- 9) Faac cannot be held responsible for failure to observe technical standards in the construction of gates and doors, or for any deformation of the gates which may occur during use.
- 10) Installation must comply with UNI 8612, CEN pr EN 12453 and CEN pr EN 12635.
The degree of safety of the automation must be C+D.
- 10A) IEC 335-2-95
- 11) Before attempting any job on the system or operator, cut out electric power and disconnect the batteries, if installed.
- 12) An omnipower switch shall be provided for the installation with an opening distance of the contacts of 3 mm or more. Alternatively, use a 6A thermomagnetic breaker with multi-poleswitching.
- 13) Ensure that there is a differential switch up-line of the electrical system, with a trip threshold of 0.03 A.
- 14) Check that the earthing plant is in perfect condition and connect it to the metallic parts. Also earth the yellow/green wire of the operator.
- 15) The automation is fitted with an anti-crush safety system that is a torque control device. In any case, further safety devices shall be installed.
- 16) The safety devices (e.g. photocells, safety edges, etc.) protect areas where there is a **mechanical movement hazard**, e.g. crushing, entrapment and cutting.
- 17) Each installation must be fitted with at least one flashing light (e.g. FAAC LAMP, MINILAMP, etc.) as well as a warning plate suitably fixed to the gate, besides the safety devices as per point 16 above.
- 18) Faac cannot be held responsible regarding safety and correct functioning of the automation in the event that parts other than Faac original parts are used.
- 19) Use only Faac original spare parts for maintenance operations.
- 20) Do not carry out any modifications to automation components.
- 21) The installer must supply all information regarding manual operation of the system in the event of an emergency and provide the end-user with the "End-user Guide" attached to the product.
- 22) Do not allow children or adults to stand near the product during operation.
- 23) Keep out of reach of children the remote radio controls and any control devices. The automation could be operated unintentionally.
- 24) The end-user must avoid any attempt to repair or adjust the automation personally. These operations must be carried out exclusively by qualified personnel.
- 25) **What is not explicitly stated in these instructions is not permitted.**

AUTOMATIC SYSTEM 525/530

These instructions apply to the following models:

525 - 530

Automatic systems 525-530 are designed to automate overhead spring-balanced, sectional, and counterbalanced (with special GDA 3000 accessory) doors for residential garages.

They consist of an electro-mechanical operator, electronic control appliance and courtesy lamp built into a single unit. The unit is fitted to the ceiling and opens the door by means of a transmission chain.

The system is non-reversing and, therefore, the door locks mechanically when the motor is not operating and, consequently, no other lock is necessary; two manual releases on the inside and outside (optional) make it possible to move the door manually in case of a power cut or fault.

Any obstacles are certain to be detected by a controlling electronic device which comes into action while the automatic system is in operation.

The 525 and 530 automated systems were designed and built for indoor use and for controlling vehicle access. Avoid any other use.

2. DIMENSIONS

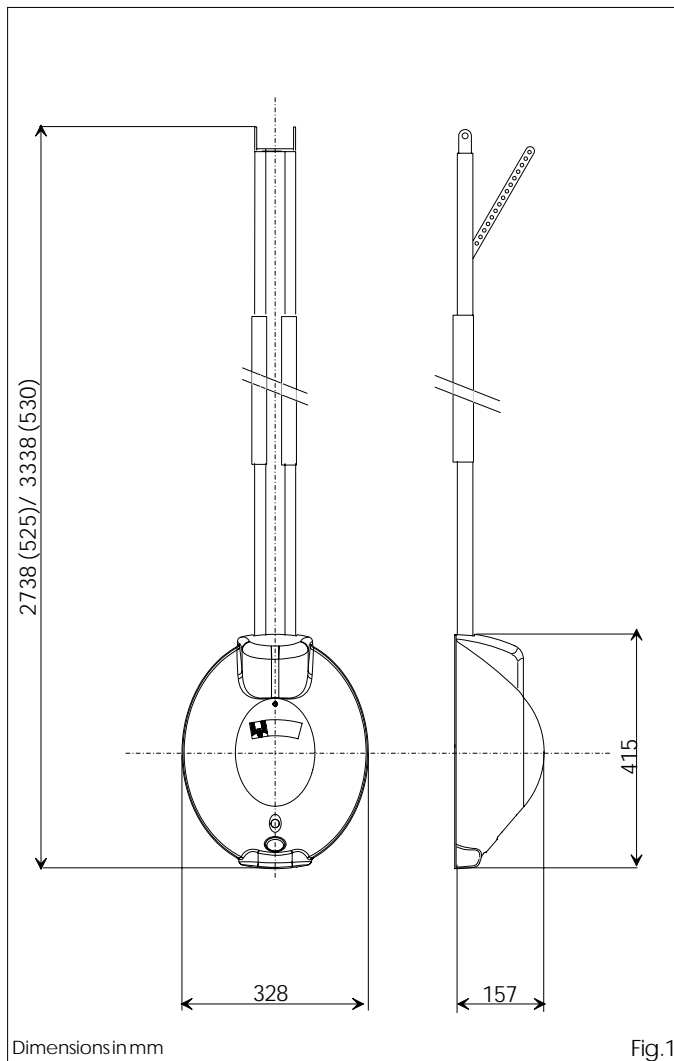

1. DESCRIPTION AND TECHNICAL SPECIFICATIONS

MODEL	525	530
Power supply	230V ac 50Hz	
Electric motor	24V dc	
Maximum absorbed power	220W	
Maximum cycles per hour	20 (with load of 28Kg at 20°C)	
Maximum consecutive cycles	6 (at 20°C)	
Minimum distance from ceiling	35mm (Fig.4 and 5)	
Maximum available travel	1900mm	2500mm
Pulling/thrust power	600N (~60Kg)	
Courtesy light	230V ac 40W max	
Courtesy light timer	2 minutes	
Carriage speed (load free)	12 cm/sec.	
Deceleration speed	6 cm/sec.	
Deceleration travel	Varies according to setup	
Internal safety device	Type 2	
Response time of built-in safety device	150msec	
Door max width	3000 mm (5000mm sectional)	
Door max height	See max available travel	
Protection class	IP20	
Ambient temperature	-20 / +55°C	

3. ANCILLARY ELECTRICAL EQUIPMENT

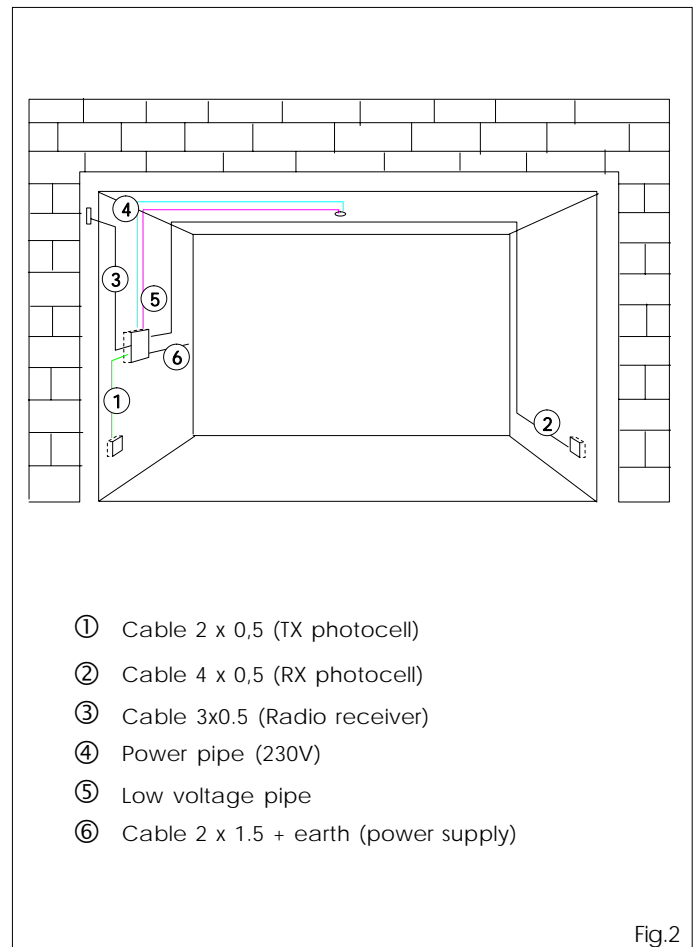

3. DESCRIPTION

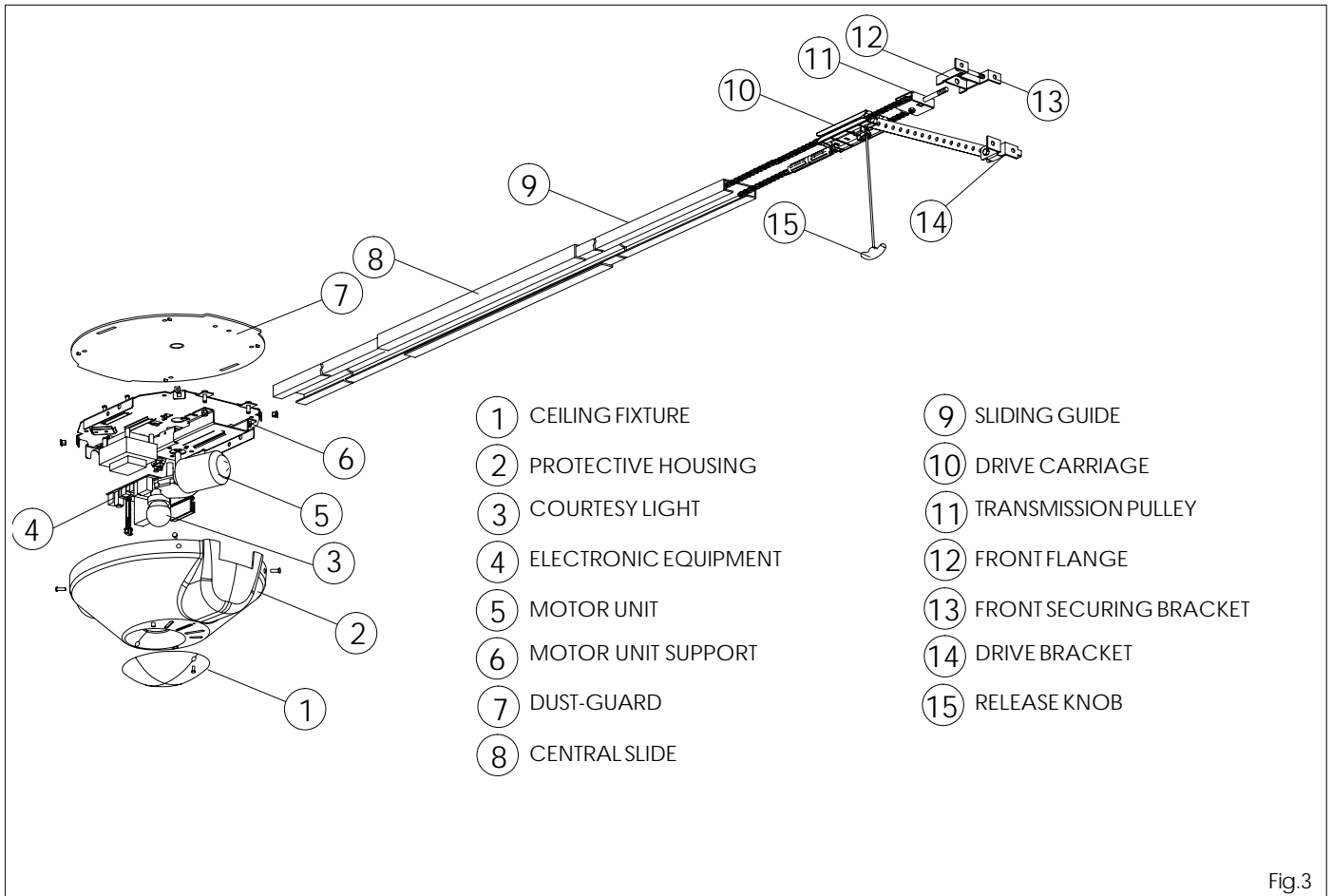

4. PRELIMINARY CHECKS

The structure of the door must be suitable for accommodating automation. In particular, check that the door dimensions conform to those indicated in the technical specifications, and that the door is sufficiently sturdy.

Check the efficiency of the door bearings and joints.

Make sure the door is free of any friction; if necessary, clean the guides and oil them with silicone lubricant, but do not use grease. Remove the door's existing closing mechanism to ensure the door is closed by the automatic system.

Check if an efficient earth plate is available for electrical connection to the operator.

Make sure there is a clearance of at least 35 mm between the ceiling and the highest sliding point of the door (fig.4 and 5).

In the case of sectional doors, check that the upper guide roller is in the horizontal part of the guide when the door is closed (fig.6).

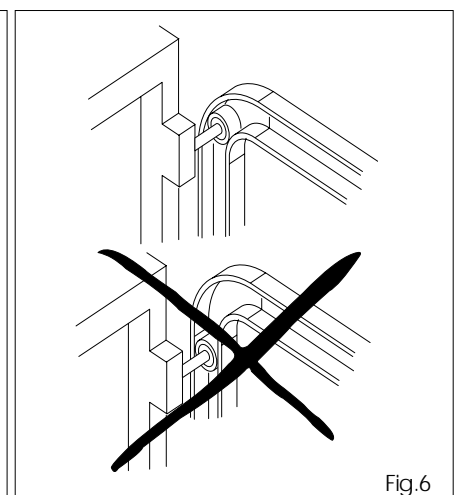
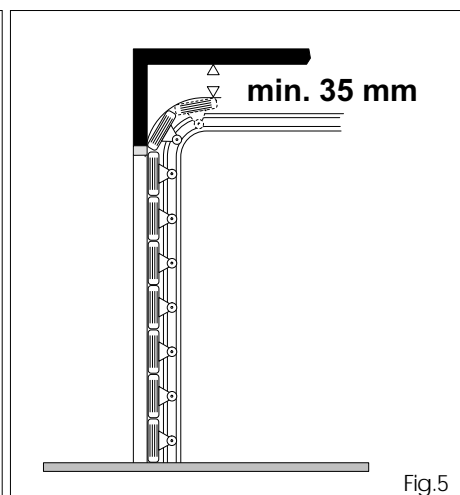
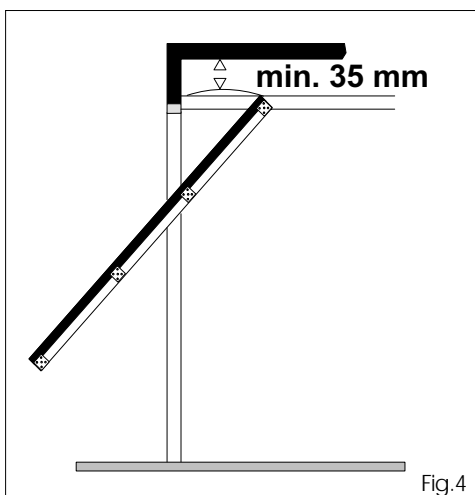

5. OPERATOR ASSEMBLY

N.B.: Screws and expansion plugs for securing the operator to the infrastructure are not supplied.

5.1 If using the outside release device (optional item), withdraw the carriage from the guide, and fit the cable in the appropriate seat on the carriage, as shown in figure 7.

5.2 For the 530 operator, we advise you to use the optional guide (fig.8 ref.B), fitting it on the central slide (fig.8 ref.C).

5.3 Insert the longitudinal member with chain in the central slide (fig. 9) until it meets the metal projection (fig.8 ref.D).

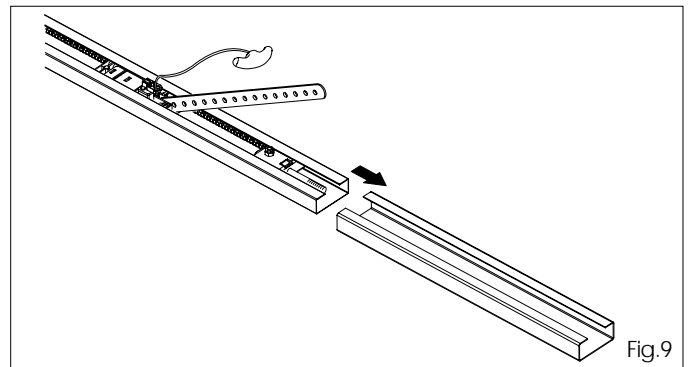
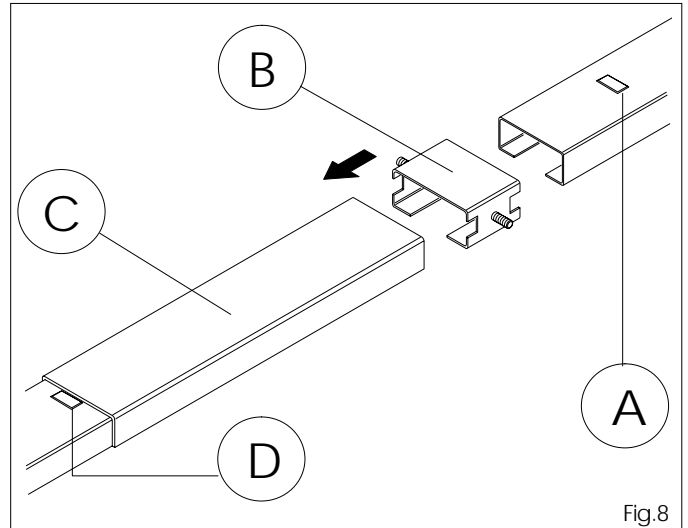
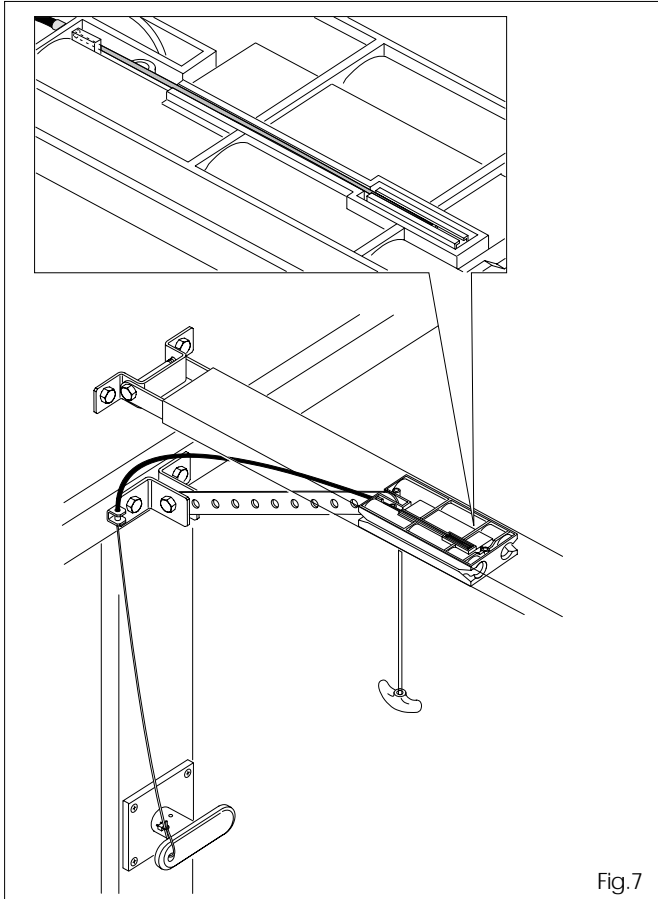

5.4 Fit a new longitudinal member (fig.10) in the already installed unit, making sure that the metal projection shown in Fig. 8 ref.A comes into contact with the central slide.

5.5 Remove the housing, unscrew the lamp and, using a suitable wrench, remove the nuts securing the motor unit to the operator (fig.11).

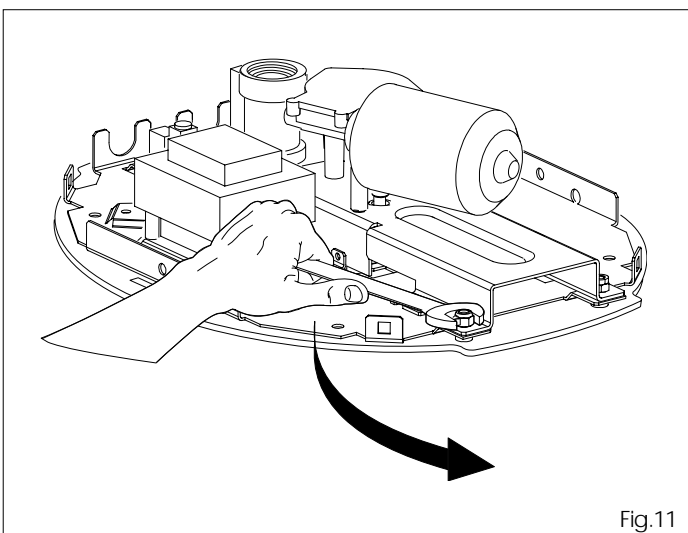
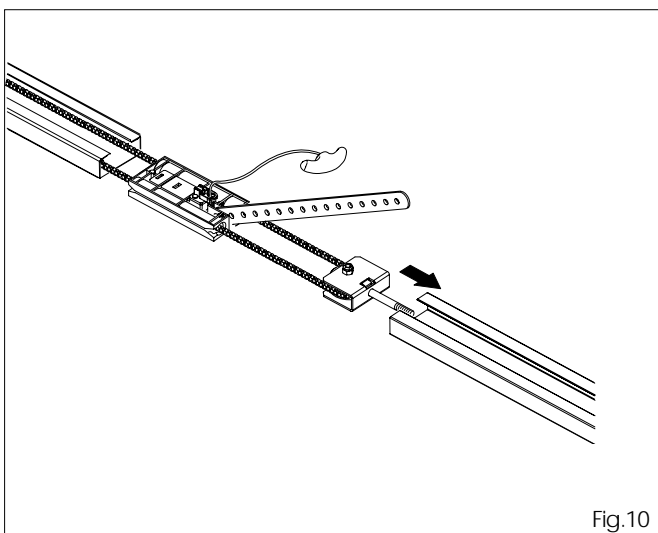

5.6 Offer the assembled guide to the operator.

5.7 Lift up the motor unit, taking care not to damage the electronic equipment, couple the pinion gear to the chain and fit it in the motor shaft (fig.12).

5.8 Re-position the motor unit and insert the longitudinal member – as shown in figure 13 (ref. A) - up to the stop.

5.9 Tighten the motor unit with an appropriate wrench (fig. 13 ref.B).

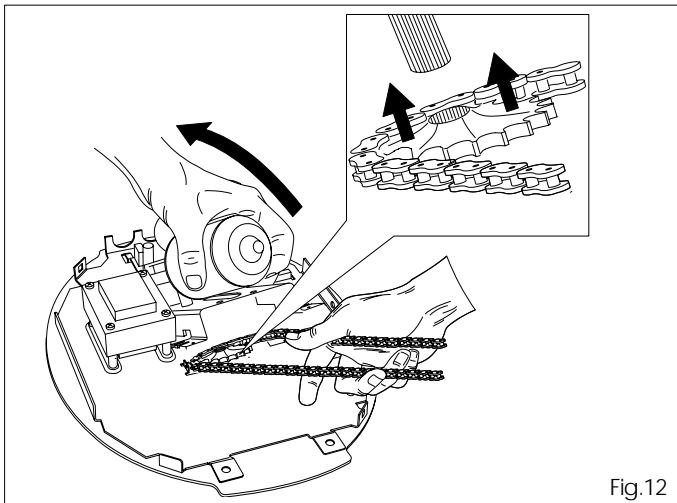

Fig.12

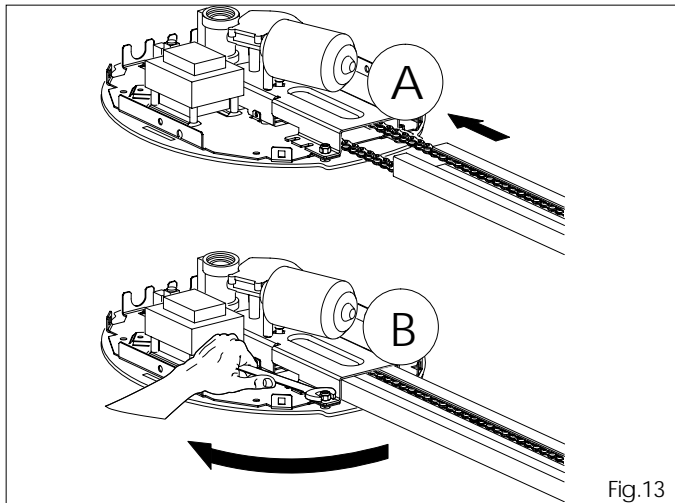

Fig.13

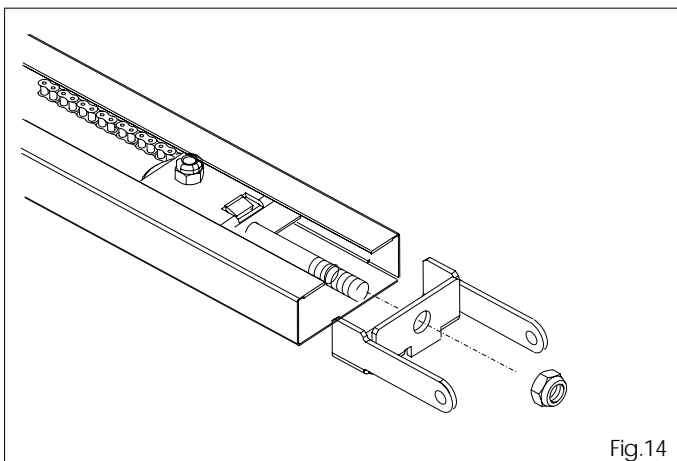

Fig.14

5.10 Fit the flange into the sliding guide and lock with the nut (fig.14).

5.11 Position the operator on the ground, vertically respect to floor (fig. 15 ref. A).

5.12 Check chain tension, making sure that these distances are equal (as shown in fig. 15 ref. B) : lower chain - upper chain; upper chain - upper rail joint.

5.13 Adjust chain tension if necessary, using the nut as indicated in fig. 15 ref. C.

N.B. : To apply tension to the chain, turn the nut clock - wise.

To slacken the chain, turn the nut anti clock - wise

Warning: too much chain tension could damage the motor unit.

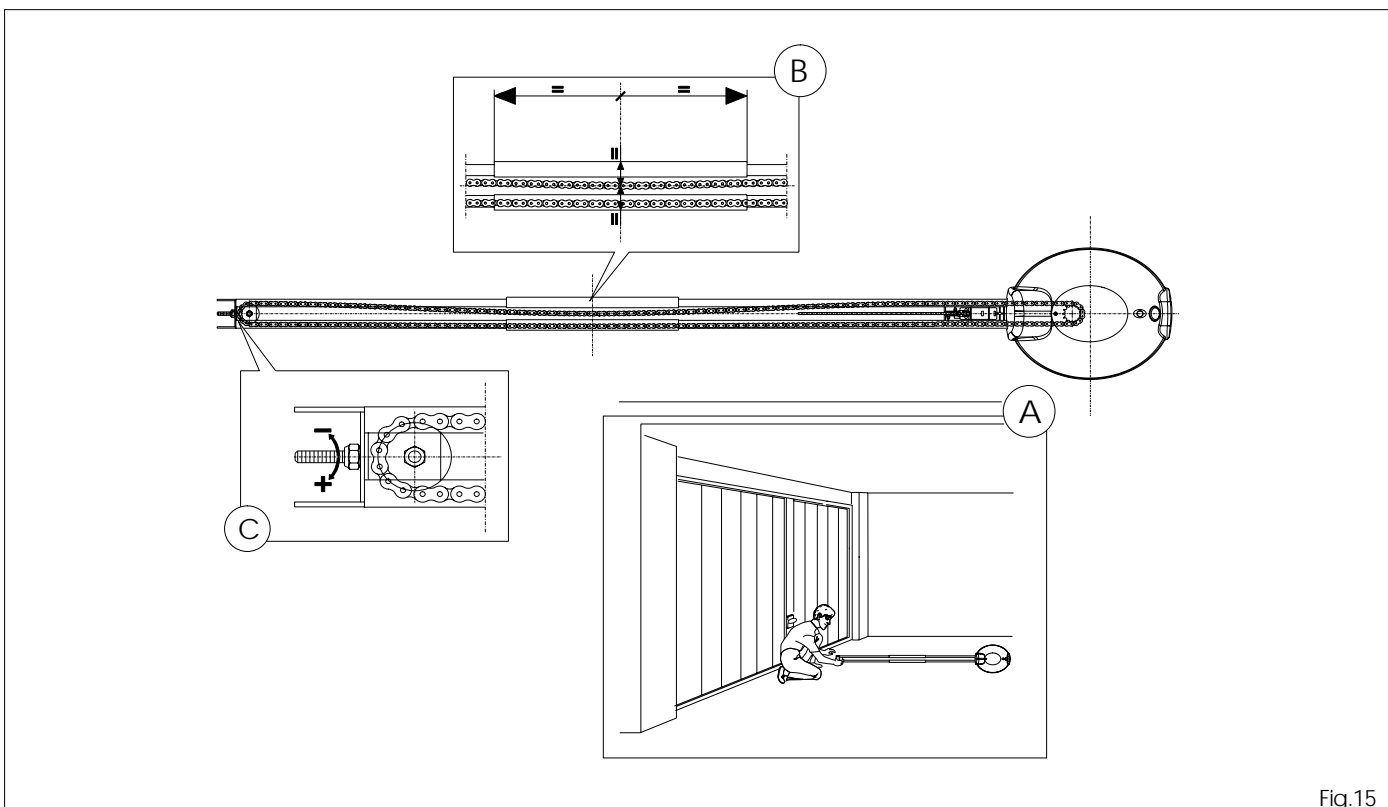

Fig.15

6. INSTALLATION

- 6.1 Find the mid-point of door and ceiling and mark the two lines with a highlighter.
- 6.2 Find the highest movement point of the door and mark this on the lintel.
- 6.3 Position the securing bracket 5 mm above the line you had marked, which must be centered with respect to the door (fig. 16).
- 6.4 Mark the two bracket securing points and drill the necessary holes.
- 6.5 Next, using screws and washers, screw the bracket on the expansion plugs (fig. 16).

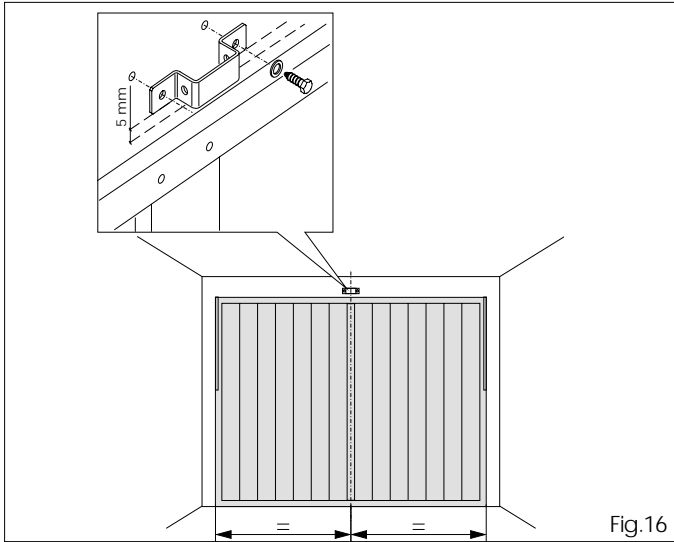

Fig.16

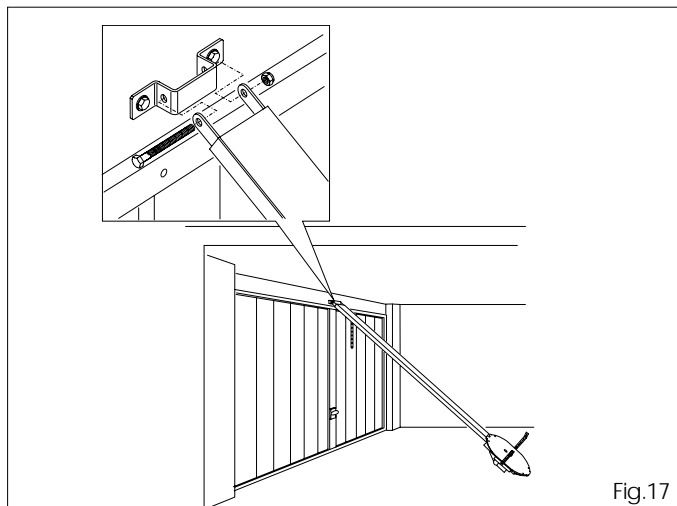

Fig.17

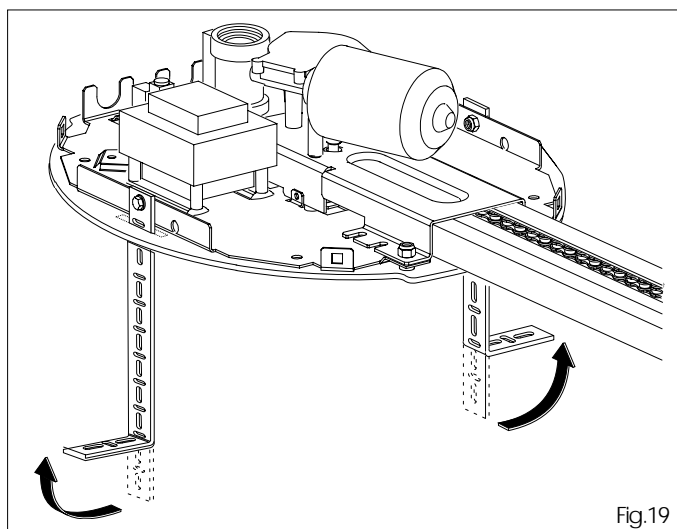

Fig.19

- 6.14 Place the knot inside the knob – as shown in fig. 20 ref. B – and close it.
- 6.15 If using the central support guide, shape the brackets, lock them with a nut and secure them to the ceiling (fig. 21).

6.6 Place the operator on the ground, lift up the sliding longitudinal member and step toward the bracket – fit the screw and tighten the nut (fig. 17).

6.7 Lift up the operator, making sure it is horizontal with respect to the door – use a spirit level.

6.8 When you have reached the correct position, measure the distance between ceiling and operator so that you can shape the securing brackets in advance.

6.9 Fit the supplied brackets in the slots and secure the operator with the nut (fig. 18).

6.10 Bend the securing brackets in line with the measurements you had taken (fig. 19).

6.11 Lift up the operator, place it in its correct position, and mark the securing holes.

6.12 Drill, insert the expansion plugs and, using screws and washers, secure the motor unit to the ceiling (fig. 20 ref. A).

6.13 First establish the height of the release knob, cut off excess cord, and make a knot on the cord end.

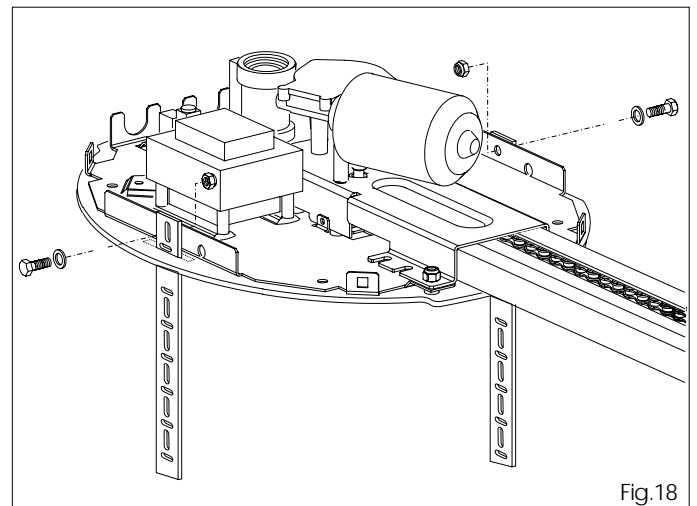

Fig.18

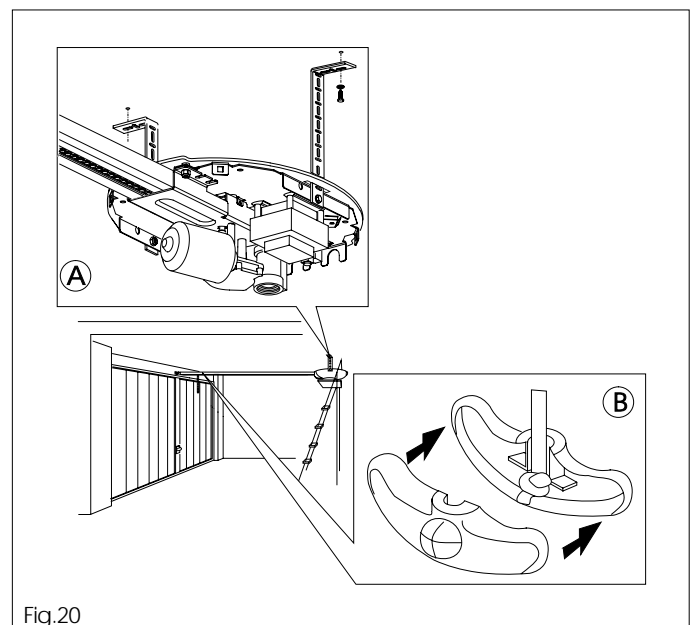

Fig.20

- 6.16 For sectional doors, see point 6.25.
- 6.17 Secure the attachment to the drive shaft, using a suitable screw and nut (fig. 22).
- 6.18 Release the operator, by pulling the release lever downward (fig.23).
- 6.19 Close the overhead door.
- 6.20 Take the released carriage to the closing point.
- 6.21 Rest the attachment on the door, in a central position with respect to the mid-line you had marked out.
- N.B.: The distance between drive bracket and sliding rail bracket must not exceed 20cm (max 30°) (fig.24).**
- 6.22 Check the position, drill and secure with suitable screws (fig. 24).

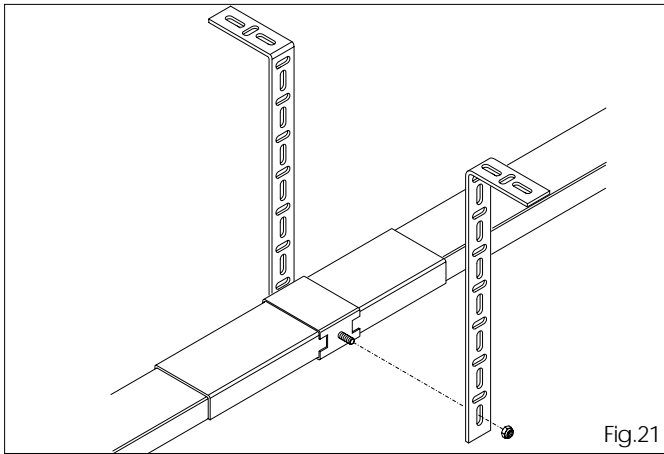

Fig.21

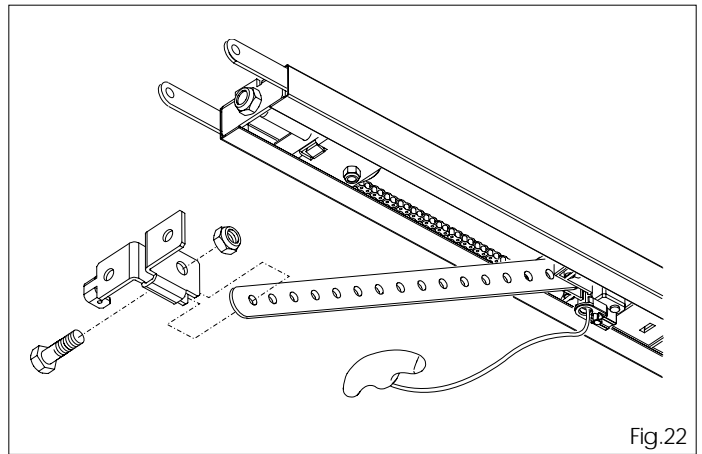

Fig.22

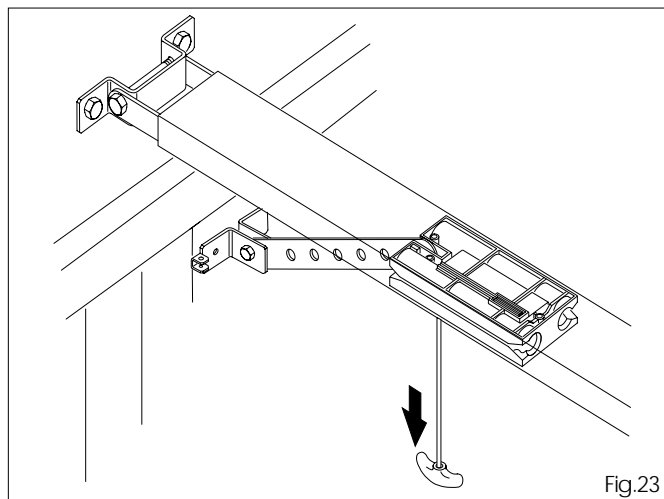

Fig.23

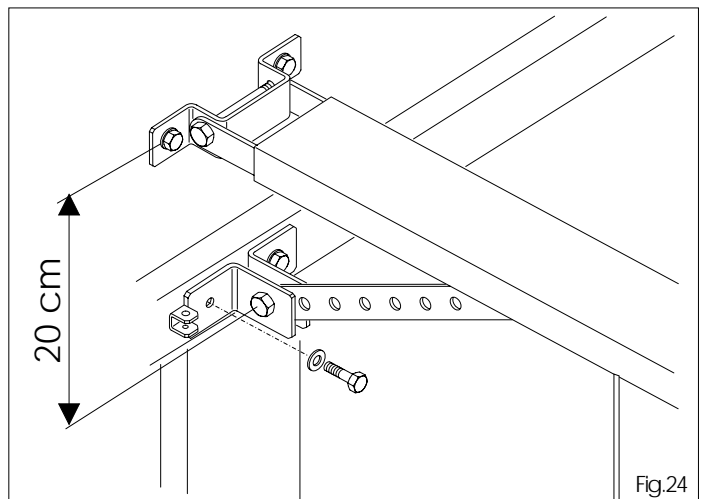

Fig.24

- 6.23 Re-lock the automatic system by pulling the handle sideways (fig.25) N.B.: on release, make sure you can see the red "LOCK" indication window under the carriage – this means it was correctly reset.
- 6.24 Important: slide the door along the rail to re-locate the hook-up point.
- 6.25 For sectional doors that require it, fit the arm shown in figure 26 ref. A on the attachment and carry on from point 6.18.

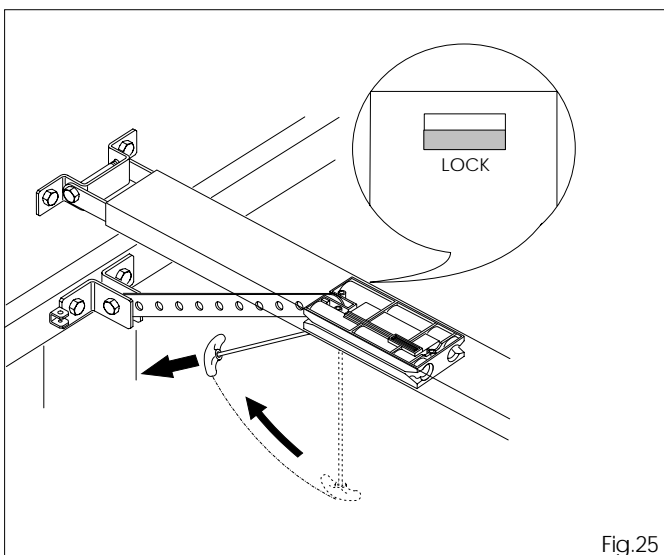

Fig.25

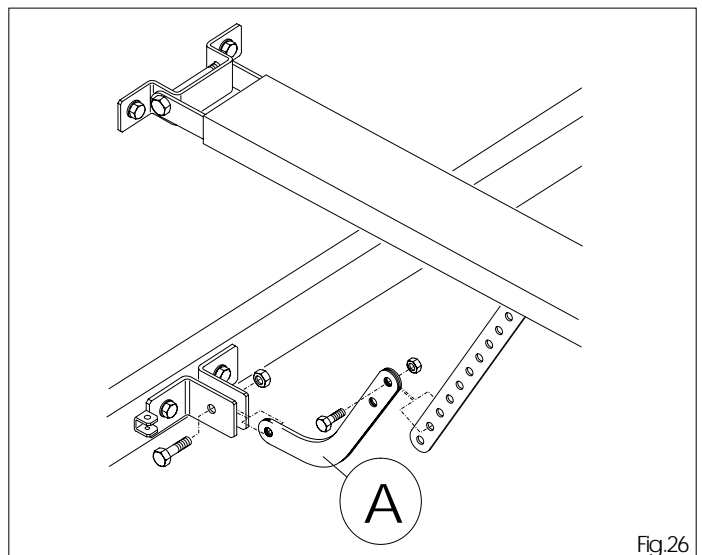

Fig.26

7. CONNECTION OF 525 MPS ELECTRONIC CARD

IMPORTANT: Before attempting any work on the card (connections, programming, maintenance), always turn off power.

Observe points 10, 11, 12, 13 and 14 of the GENERAL SAFETY RULES.

Observing the indications in fig. 2, install the raceways and make the electrical connections from the 525 MPS electronic appliance to the selected accessories (fig. 28).

Always separate power cables from control and safety cables (push-button receiver, photocells, etc.). To prevent any electric noise whatever, use separate sheaths.

TECHNICAL SPECIFICATIONS

Power supply voltage	230V ac 50Hz
Power supply for accessories	24Vdc
Accessories max. load	200 mA
Ambient temperature	-20°/+55°C
Fuses	transf./motor primary winding
Quick-fit connector	for decoding cards and RPreceivers
Function logics	Automatic/Semi-automatic
Terminal board connections	Open/Stop/Safety devices/Fail-safe/Flashlight
Courtesy light timer	2 min

525 MPS CARD COMPONENTS

F1	Fuse for transf. primary winding, 1A
F2	Motor fuse, 10A
F3	Fuse for 0,5A accessories output
J1	Low voltage terminal board for inputs /accessories
J2	Rapid connector for decoding/RP receivers cards
J3	230V power supply input terminal board
J4	Connector for transformer primary winding
J5	Courtesy light connector
J6	Flashlight output terminal board
J7	Connector for transformer secondary winding
J8	Motor output connector
P1	Open push-button
P2	Set-up push-button
LK1	Enable/disable fail-safe
LK2	Varies sensitivity of reversing device

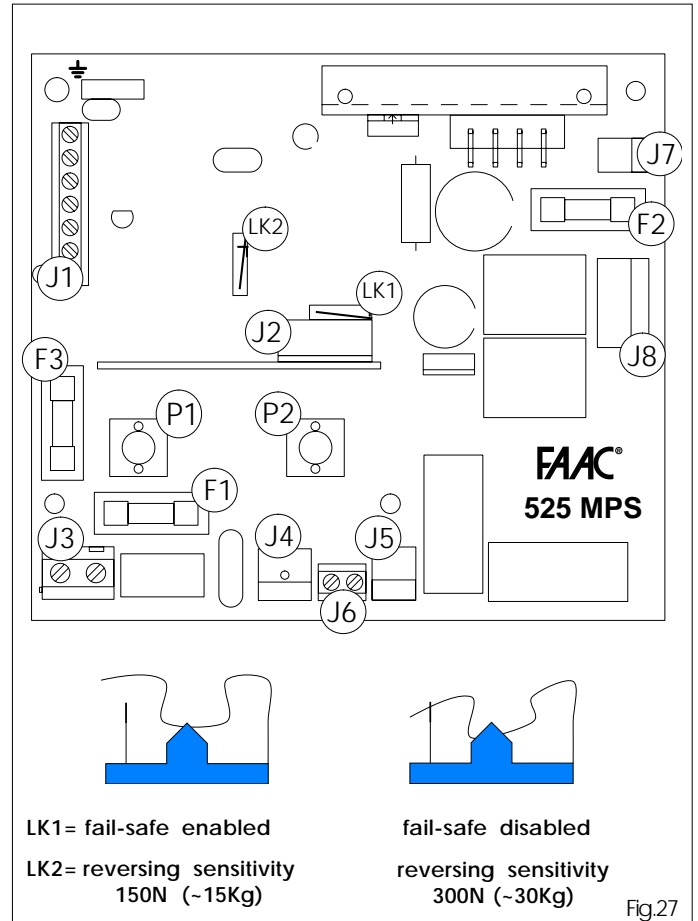

DESCRIPTION

TERMINAL BOARD J1 (low voltage)

OPEN=Open Command (N.O.)

Any device (push-button, detector, ...) which, by closing a contact, supplies an opening (or closing) pulse to the door.

To install several Open devices, connect N.O. contacts in parallel.

STOP=Stop command (N.C.)

Any device (e.g. a push-button) which, by opening a contact, stops door movement.

To install several stop devices, connect the N.C. contacts in series.

N.B.: if stop devices are not used, jumper connect STOP to the inputs common contact.

⊖ =input/negative accessories supply common contact.

⊕ =Accessories supply positive pole (24V dc 200mA max)

FSW= Closing safety-devices contact (N.C.)

Safety devices are all devices (photocells, sensitive edges, ...) with N.C. contact, which, if there is an obstacle in the area they protect, operate to reverse door closing movement.

If the safety devices are activated when the door is locked or open, they prevent it from closing.

To install several safety devices, connect the N.C. contacts in series.

N.B.: if safety devices are not connected, jumper connect FSW to the inputs common contact.

-FSW TX= Terminal for connection of the negative pole (-) of the photocells transmitter (TX).

CONNECTOR J2 (low voltage)

Connector J2 is used for rapid connection of MINIDEC, DECODER, and RP RECEIVER cards.

Insert and remove the cards after cutting power.

TERMINAL BOARD J3 (high voltage)

Terminal board for power supply of 230V ~50Hz (F=phase N= neutral)

Connect the system's earth wire to the dedicated terminal (see ID sticker – fig.31 ref.A).

TERMINAL BOARD J6 (high voltage)

230V - Terminal board for connection of flashlight.

LK1 JUMPER (enable/disable fail-safe)

The 525 MPS card has another safety device – the FAIL-SAFE – which, prior to any activation, controls if the N.C. contact on the photocell receiver (fig.27) is operating efficiently.

JUMPER LK2 (150N/300N)

Serves to vary the sensitivity of the reversing device (fig. 27).

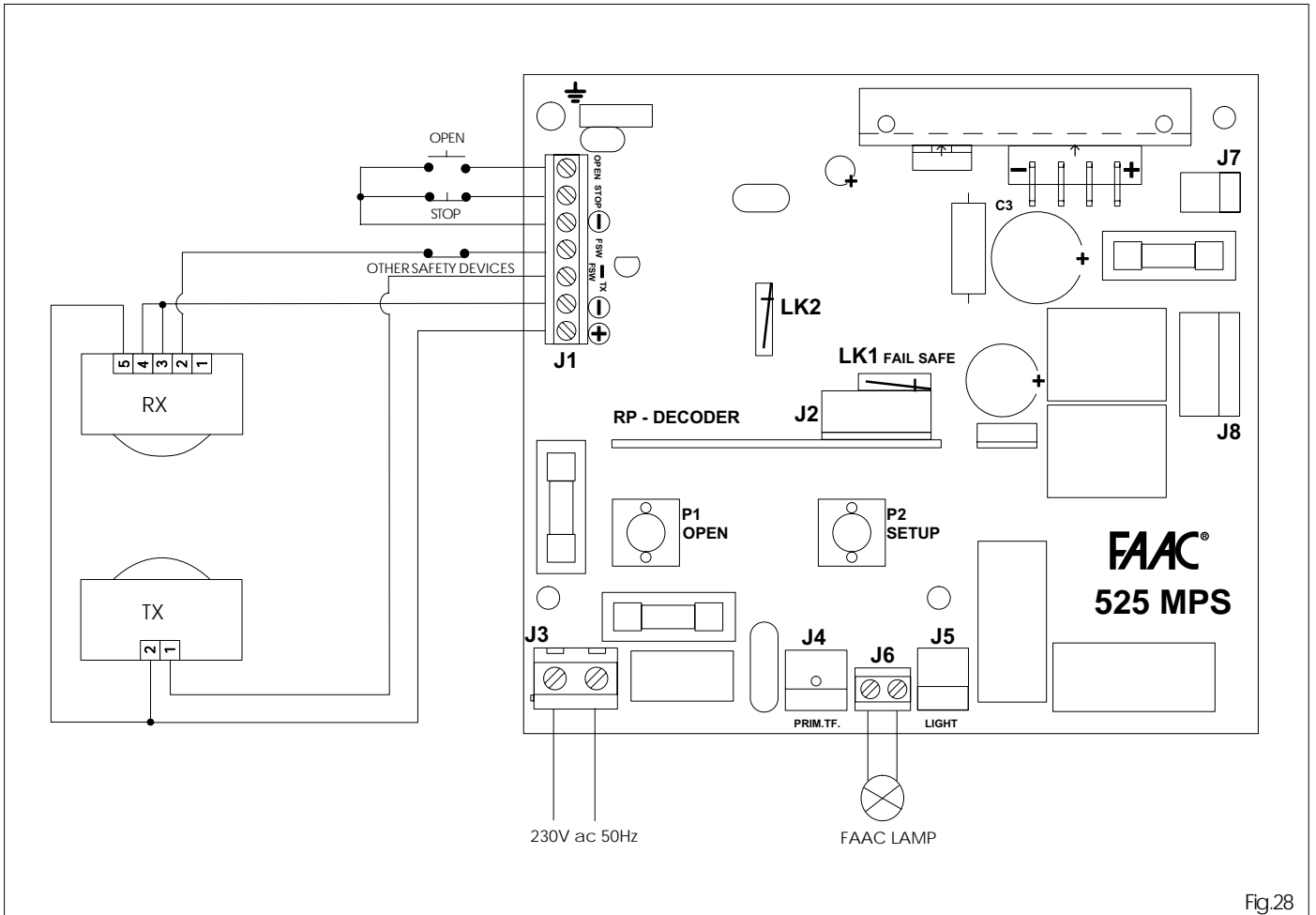

Fig.28

8. ANTENNA INSTALLATION (OPTIONAL)

8.1 If you are using an RP receiver, and wish to increase its range, you can use an external 433 MHz antenna (antenna connection instructions are on the rear of the RP receiver blister-pack).

8.2 Pick up the housing and, using an appropriate bit, drill from the inside outward in the guided area (fig. 29).

8.3 Turn the housing toward the front, fit the antenna and secure it from the inside with a suitable nut (fig. 30).

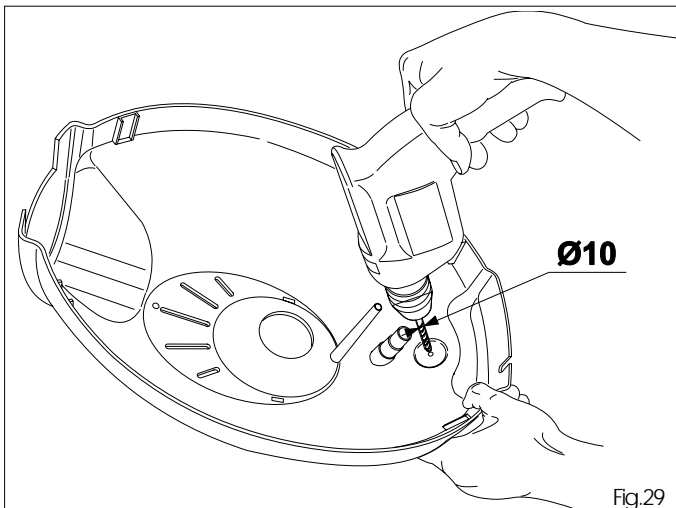

Fig.29

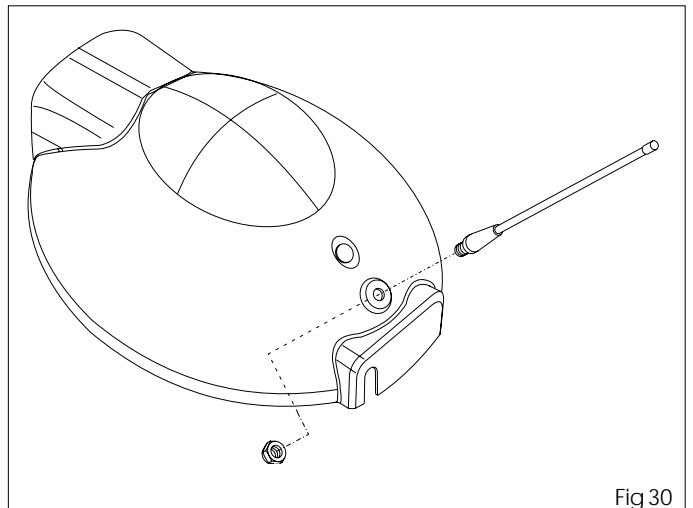

Fig.30

9. CONNECTIONS

9.1 Connect the power cable, as shown in figure 31, securing it with a clamp in the indicated area.

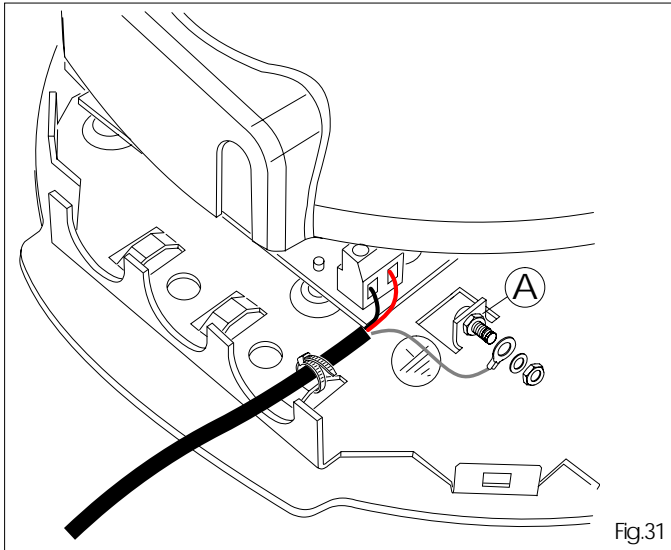

Fig.31

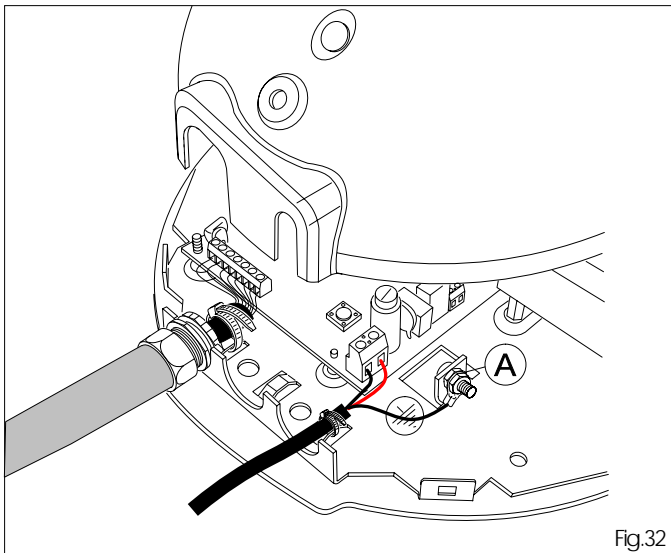

Fig.32

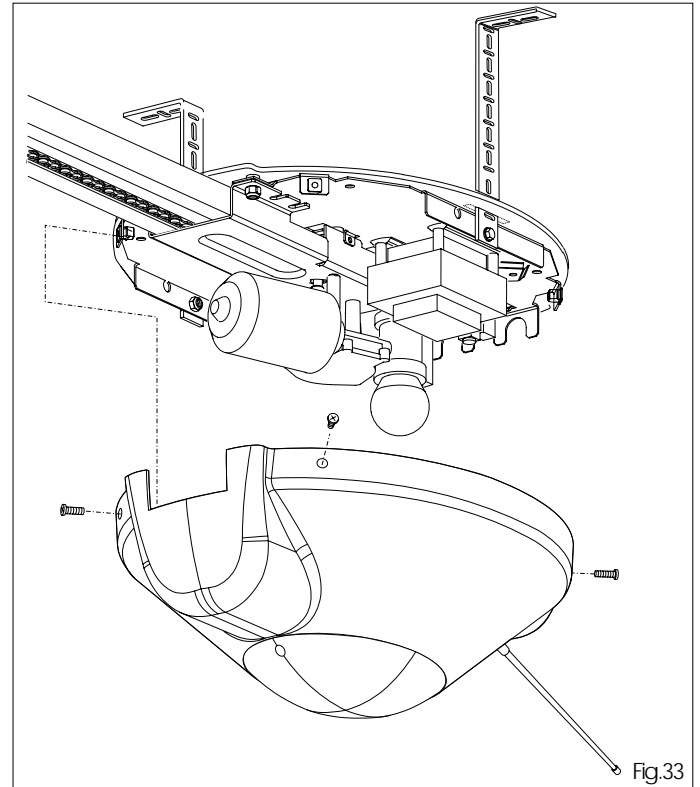

Fig.33

9.2 Fit the screw in the appropriate seat and tighten with washer and nut (fig.31 ref. A).

9.3 Position the earth eyelet on the screw, add a washer and tighten with the nut (fig. 32 ref. A).

9.4 If you are using tube sleeves to secure the cables, make a slot as shown in figure 32.

9.5 Screw the lamp in the appropriate lamp-holder.

9.6 Secure the operator housing using appropriate screws (fig. 33).

10. PROGRAMMING

To access the programming push-button, dismantle the courtesy light ceiling fixture, unscrewing the appropriate screw. Slide the ceiling fixture in the direction shown by the arrow (fig.34).

INITIAL SET-UP

The obstacle detector does NOT operate during this initial procedure – this means that the operator is using the motor's maximum power to move the door.

Further, the Fail-safe procedure is not active.

The set-up procedure enables you to establish the following:

- anti-crushing safety levels at opening and closing.
- deceleration points
- operator's fully open and fully closed points
- pause interval

This procedure can be carried out at any time, with the operator in any position.

Two function logics are available on this appliance:

AUTOMATIC (TABLE 1)

SEMI-AUTOMATIC (TABLE 2)

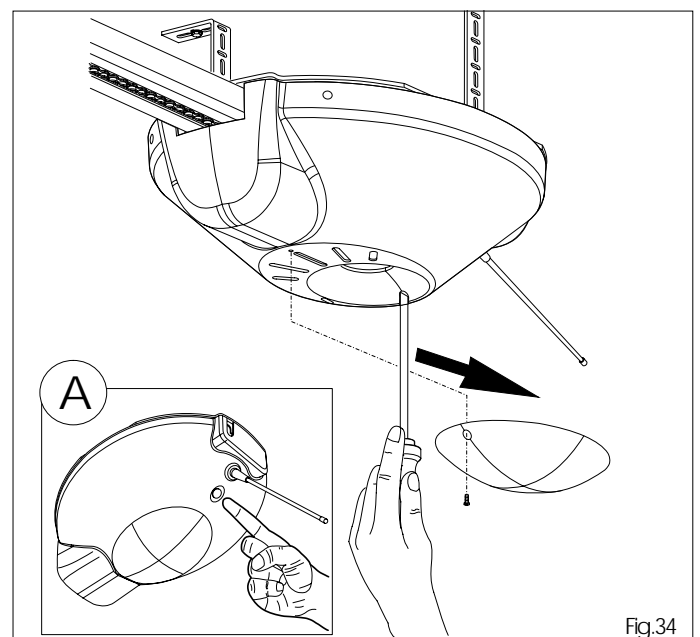

Fig.34

AUTOMATIC SET-UP

The set-up procedure is executed automatically just with a pulse.

MANUAL SET-UP

This procedure enables you to select the deceleration points, the fully open point, and pause time.

AUTOMATIC SET-UP WITH LOGIC "E" (SEMI-AUTOMATIC)

Press and release the SET-UP push-button to select the logic. After 8 seconds the operator effects a closing operation until a stop is detected.

The operator now opens the door, and the opening movement finishes when the mechanical stop is recognised.

The door is immediately closed.

The electronic appliance establishes the deceleration points. If the SETUP procedure was **successful**, the courtesy lamp stays lighted for 5 seconds. During this time, in order to reduce the load on the release system, open pulses can be sent within 2 seconds of each other to reverse the release carriage. A pulse equals travel of 5 millimetres.

N.B.: the carriage can be seen to reverse only when the automated system is operating normally.

MANUAL SET-UP WITH LOGIC "E" (SEMI-AUTOMATIC)

Press and release the SET-UP push-button to select the logic. Carry out the following procedure within 8 seconds after pressing the SETUP push-button, otherwise the operator will execute automatic SETUP.

1st OPEN: the operator effects a closing operation until a stop is detected.

2nd OPEN: the operator continues with an opening movement.

3rd OPEN: defines the point at which start of deceleration is required.

4th OPEN: defines the end of the opening** movement.

5th OPEN: starts closing movement.

6th OPEN: defines the point at which start of deceleration is required.

Allow the operator to reach the stop.

If the SETUP procedure was **successful**, the courtesy lamp stays lighted for 5 seconds. During this time, in order to reduce the load on the release system, open pulses can be sent within 2 seconds of each other to reverse the release carriage. A pulse equals travel of 5 millimetres.

N.B.: the carriage can be seen to reverse only when the automated system is operating normally.

AUTOMATIC SET-UP WITH LOGIC "A" (AUTOMATIC)

Hold down the SET-UP push-button to select the logic until the courtesy light goes on (about 5 seconds).

After 8 seconds the operator effects a closing operation until a stop is detected.

The operator now opens the door, and the opening movement finishes when the mechanical stop is recognised.*

The door is immediately closed.

The electronic appliance establishes the deceleration points, and pause time is fixed at 3 minutes.

If the SETUP procedure was **successful**, the courtesy lamp stays lighted for 5 seconds. During this time, in order to reduce the load on the release system, open pulses can be sent within 2 seconds of each other to reverse the release carriage. A pulse equals travel of 5 millimetres.

N.B.: the carriage can be seen to reverse only when the automated system is operating normally.

MANUAL SET-UP WITH LOGIC "A" (AUTOMATIC)

Hold down the SET-UP push-button to select the logic until the courtesy light goes on (about 5 seconds). Carry out the following procedure within 8 seconds after pressing the SETUP push-button, otherwise the operator will execute automatic SETUP.

1st OPEN: the operator effects a closing operation until a stop is detected.

2nd OPEN: the operator continues with an opening movement.

3rd OPEN: defines the point at which start of deceleration is required.

4th OPEN: defines the end of the opening movement and starts the pause time count** (3 minutes max.).

5th OPEN: interrupts the pause time count and starts the closing movement.

6th OPEN: defines the point at which start of deceleration is required.

Allow the operator to reach the stop.

If the SETUP procedure was **successful**, the courtesy lamp stays lighted for 5 seconds. During this time, in order to reduce the load on the release system, open pulses can be sent within 2 seconds of each other to reverse the release carriage. A pulse equals travel of 5 millimetres.

N.B.: the carriage can be seen to reverse only when the automated system is operating normally.

* Otherwise, an OPEN pulse may replace the stop.

** Otherwise, the stop can be used during opening.

IMPORTANT: At set-up, if the operator does not effect any movement when the OPEN push-button (see fig.34 ref. A) is pressed, check that the housing is in correct position.

FUNCTION LOGICS

Closes

Table 1 AUTOMATIC Logic

OVERHEAD DOOR	OPEN	STOP	SAFETY DEVICES
CLOSED	Opens and closes after the pause time	No effect**	No effect
OPEN FOR PAUSE	Restarts pause time count*	Locks *	Restarts pause time count*
CLOSING	Reverses motion	Locks **	Reverses motion
OPENING	No effect	Locks **	No effect *
LOCKED	Closes	No effect**	No effect *

Table 2 SEMI-AUTOMATIC Logic

OVERHEAD DOOR	OPEN	STOP	SAFETY DEVICES
CLOSED	Open	No effect**	No effect
OPEN	Closes	No effect**	No effect *
CLOSING	Reverses motion	Locks **	Reverses motion
OPENING	Locks	Locks **	No effect *
LOCKED	Closes	No effect**	No effect *

* Prevents closing if pulse is maintained

* Prevents closing and/or opening if pulse is maintained

When installation has been completed, check the efficiency of the automated system and safety devices, and then apply the "danger" warning sticker (fig.35) on the panel of the up-and-over door to make it easy to see.

Apply the sticker, which indicates the release device of the automated system (fig.35).

11. OPTIONAL ACCESSORIES

- If you are using the card for the CN60-E Sensitive Edge, a compartment is provided for it inside the operator housing in the position shown in figure 36.
 - Floating batteries installation procedure: fit them on the operator with the appropriate bracket, and secure them with screw and nut in the position shown in figure 37.
- ATTENTION! If replacing batteries, cut out electrical power before attempting any operation.

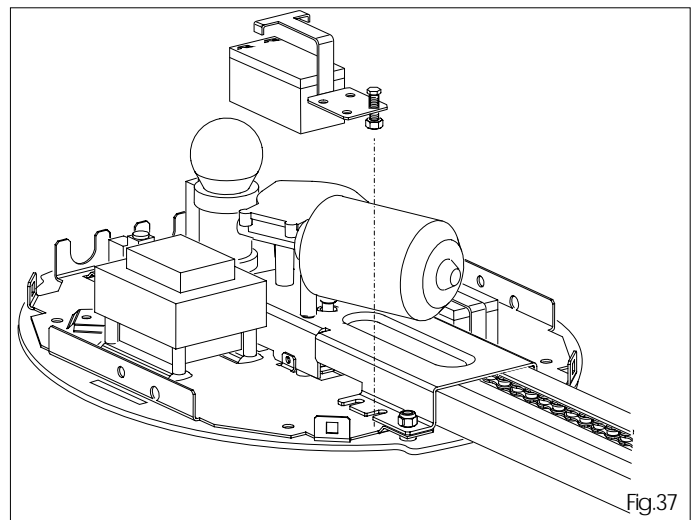
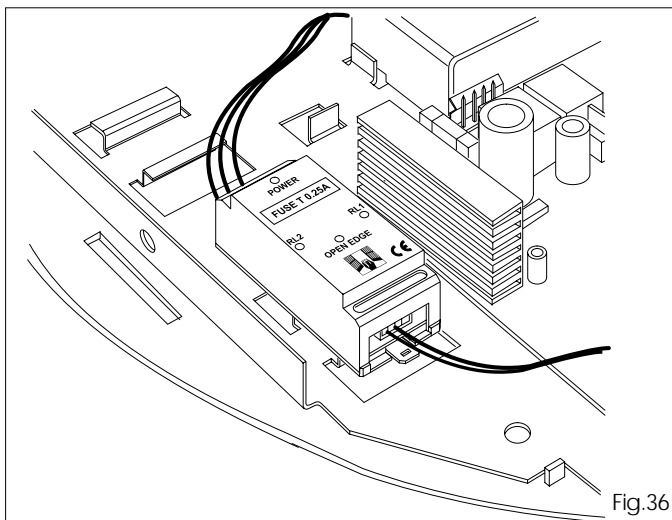
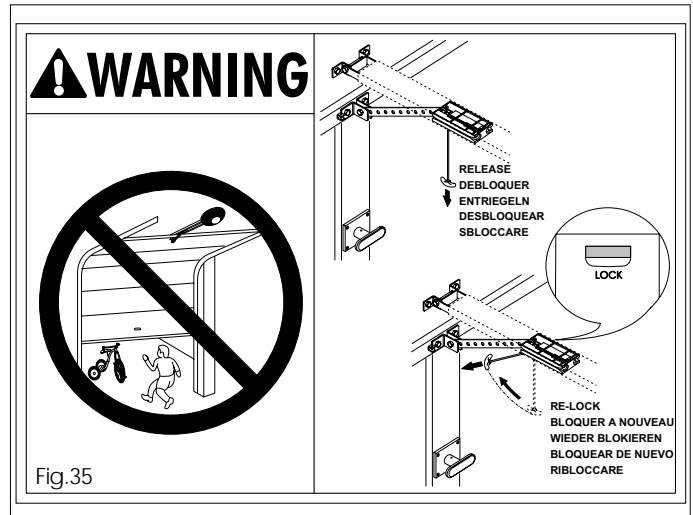

- Two external release systems can be fitted:
 - with handle (fig.38 ref.A)
 - with wrench (fig.38 ref.B)
- Counterbalanced doors can be automated by using the accessory shown in fig. 39 (GDA 3000).

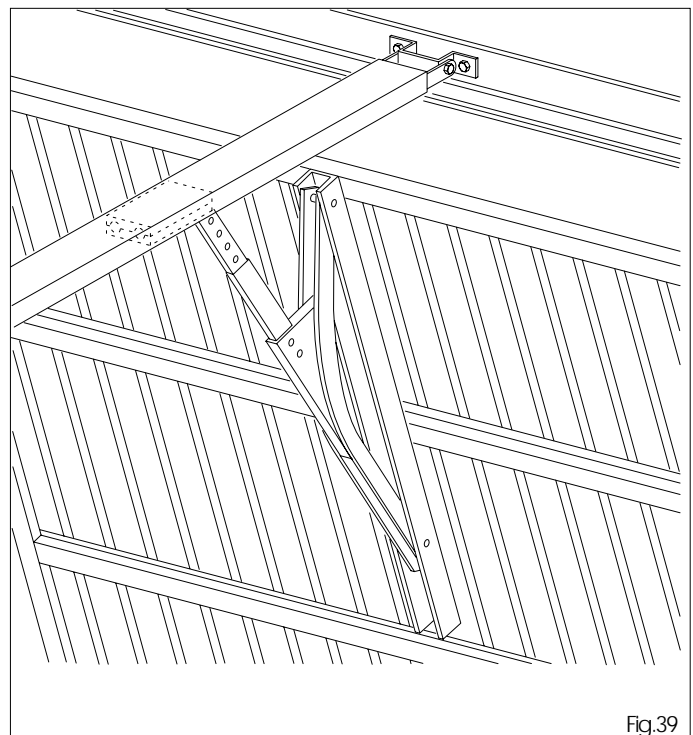
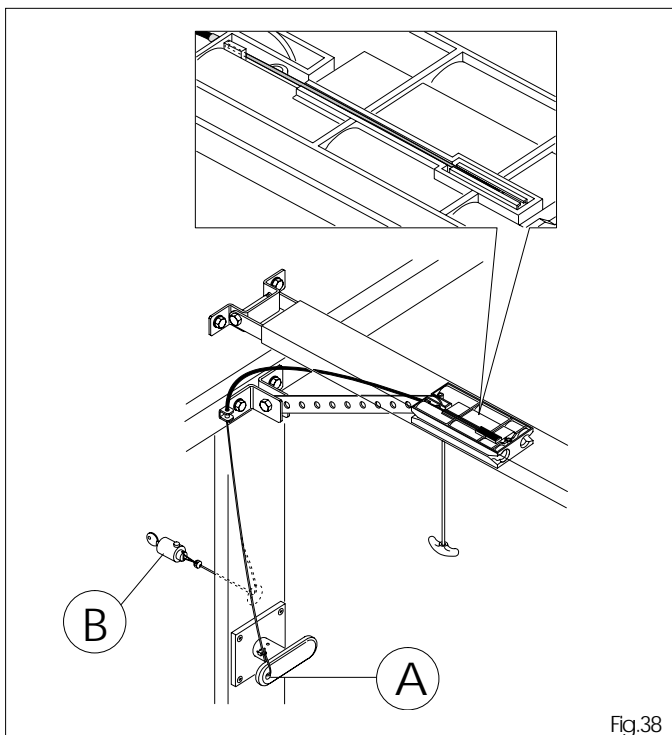

USER'S GUIDE

AUTOMATIC SYSTEMS 525-530

Read the instructions carefully before using the product and store them for future use.

GENERAL SAFETY REGULATIONS

If correctly installed and used, 525-530 automatic systems ensure a high degree of safety. Some simple rules on behaviour can prevent accidental trouble:

- Do not, under any circumstances, stand under the overhead door.
- Do not allow children, persons or things near the automatic systems, especially while they are operating.
- Keep remote-controls, or other pulse generators that could open the door, well away from children.
- Do not allow children to play with the automatic system.
- Do not willingly obstruct door movement.
- Prevent any branches or shrubs from interfering with door movement.
- Keep the indicator-lights efficient and easy to see.
- Do not attempt to activate the door by hand unless you have released it.
- In the event of malfunctions, release the door to allow access and wait for qualified technical personnel to do the necessary work.
- When you have set manual operation mode, cut power to the system before restoring normal operation.
- Do not in any way modify the components of the automation system.
- Do not attempt any kind of repair or direct action whatever and contact qualified FAAC personnel only.
- At least every six months: arrange a check by qualified personnel of the automatic system, safety devices and earth connection.

DESCRIPTION

Automatic systems 525-530 are designed to automate overhead spring-balanced, sectional, counterbalanced (with special GDA 3000 accessory) doors for residential garages.

The automatic systems consist of an electro-mechanical operator, electronic control appliance, courtesy lamp and protection housing built into a single unit.

The system is non-reversing and, therefore, the door locks mechanically when the motor is not operating and, consequently, no other lock is necessary; a manual release makes it possible to move the door in case of a power cut or fault.

An electronic device ensures that any obstacles are detected.

The door is normally closed; when the electronic control unit receives an opening command from the remote control, or from any other type of pulse generator (fig.1), it activates the electric motor which, by means of a transmission chain, pulls the door open to allow access.

-If the automatic mode was set, the door closes automatically after pause time has elapsed.

An opening pulse supplied during opening has no effect.

-If the semi-automatic mode was set, a second pulse must be sent to close the door again.

An opening pulse supplied during opening stops movement.

An opening pulse supplied during re-closing, always causes movement to be reversed.

A stop pulse (if supplied) always stops movement.

For full details of door activity in the different logics, consult the installation engineer.

Automatic systems may include safety devices (photocells) that prevent the door from closing when there is an obstacle in the area they protect.

Emergency manual opening is possible by using the release system.

The warning-light indicates that the door is currently moving.

The courtesy light is activated when the motor starts and continues for about 2 minutes after it stops.

MANUAL OPERATION

The 525-530 operators are equipped with an emergency system activated from the inside – however, a lock can be fitted on request, for activating release from the outside.

If the door has to be moved manually due to a power cut or a fault of the automatic system, use the release device as follows:

- Release the operator, by pulling the release lever downward (fig.22 ref.A).

RESTORING AUTOMATIC OPERATION MODE

Re-lock the automatic system by pulling the handle sideways (fig.2 ref.B):

N.B.: on release, make sure you can see the red "LOCK" indication window under the carriage – this means it was correctly reset.

Important: slide the door along the rail to re-locate the hook-up point.

LAMP REPLACEMENT (fig.3)

To replace the lamp, unscrew and remove the ceiling fixture support screw.

Slide the ceiling fixture in the direction shown by the arrow (fig.33).

Replace the lamp (220Vac, 40W max.).

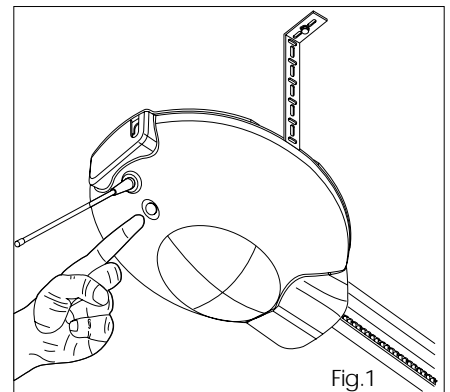

Fig.1

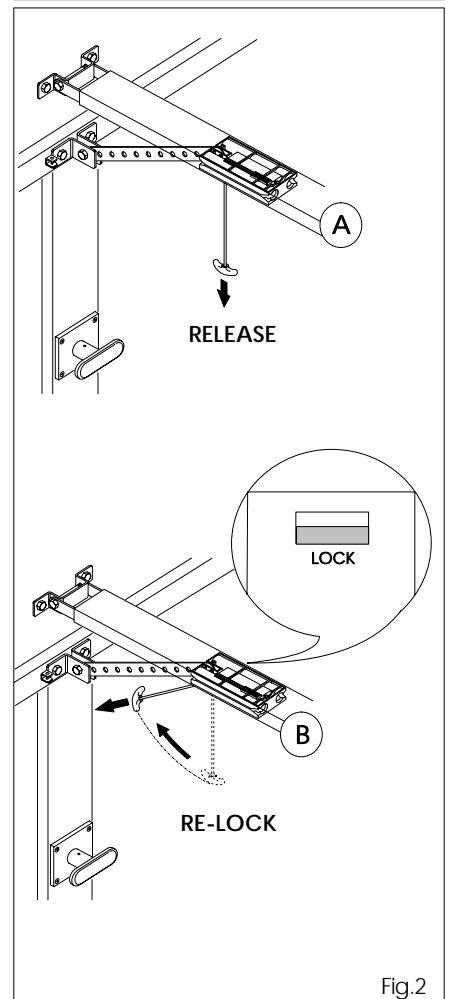

Fig.2

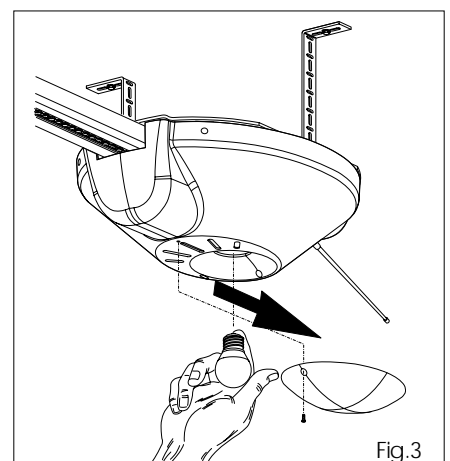

Fig.3