

## EC DECLARATION OF CONFORMITY FOR MACHINES (DIRECTIVE 98/37/EC)

**Manufacturer:** FAAC S.p.A.

**Address:** Via Benini, 1 - 40069 Zola Predosa BOLOGNA - ITALY

**Declares that:** MASTER-B / SLAVE-B control board

- is built to be integrated into a machine or to be assembled with other machinery to create a machine under the provisions of Directive 98/37/EC;
- conforms to the essential safety requirements of the following EEC directives:  
  
73/23/EEC and subsequent amendment 93/68/EEC.  
89/336/EEC and subsequent amendment 92/31/EEC and 93/68/EEC

and also declares that it is prohibited to put into service the machinery until the machine in which it will be integrated or of which it will become a component has been identified and declared as conforming to the conditions of Directive 98/37/EC.

Bologna, 01 January 2003

The Managing Director  
A. Bassi



## WARNINGS FOR THE INSTALLER GENERAL SAFETY OBLIGATIONS

- 1) **ATTENTION! To ensure the safety of people, it is important that you read all the following instructions. Incorrect installation or incorrect use of the product could cause serious harm to people.**
- 2) Carefully read the instructions before beginning to install the product.
- 3) Do not leave packing materials (plastic, polystyrene, etc.) within reach of children as such materials are potential sources of danger.
- 4) Store these instructions for future reference.
- 5) This product was designed and built strictly for the use indicated in this documentation. Any other use, not expressly indicated here, could compromise the good condition/operation of the product and/or be a source of danger.
- 6) FAAC declines all liability caused by improper use or use other than that for which the automated system was intended.
- 7) Do not install the equipment in an explosive atmosphere: the presence of inflammable gas or fumes is a serious danger to safety.
- 8) The mechanical parts must conform to the provisions of Standards EN 12604 and EN 12605.  
  
For non-EU countries, to obtain an adequate level of safety, the Standards mentioned above must be observed, in addition to national legal regulations.
- 9) FAAC is not responsible for failure to observe Good Technique in the construction of the closing elements to be motorised, or for any deformation that may occur during use.
- 10) The installation must conform to Standards EN 12453 and EN 12445.  
For non-EU countries, to obtain an adequate level of safety, the Standards mentioned above must be observed, in addition to national legal regulations.
- 11) Before attempting any job on the system, cut out electrical power and disconnect the batteries.
- 12) The mains power supply of the automated system must be fitted with an all-pole switch with contact opening distance of 3mm or greater. Use of a 6A thermal breaker with all-pole circuit break is recommended.
- 13) Make sure that a differential switch with threshold of 0.03 A is fitted upstream of the system.
- 14) Make sure that the earthing system is perfectly constructed, and connect metal parts of the means of the closure to it.
- 15) The automated system is supplied with an intrinsic anti-crushing safety device consisting of a torque control. Nevertheless, its tripping threshold must be checked as specified in the Standards indicated at point 10.
- 16) The safety devices (EN 12978 standard) protect any danger areas against **mechanical movement Risks**, such as crushing, dragging, and shearing.
- 17) Use of at least one indicator-light (e.g. FAACLIGHT 12VDC) is recommended for every system, as well as a warning sign adequately secured to the frame structure, in addition to the devices mentioned at point "16".
- 18) FAAC declines all liability as concerns safety and efficient operation of the automated system, if system components not produced by FAAC are used.
- 19) For maintenance, strictly use original parts by FAAC.
- 20) Do not in any way modify the components of the automated system.
- 21) The installer shall supply all information concerning manual operation of the system in case of an emergency, and shall hand over to the user the warnings handbook supplied with the product.
- 22) Do not allow children or adults to stay near the product while it is operating.
- 23) Keep remote controls or other pulse generators away from children, to prevent the automated system from being activated involuntarily.
- 24) Transit is permitted only when the automated system is idle.
- 25) The user must not attempt any kind of repair or direct action whatever and contact qualified personnel only.
- 26) Do not short-circuit the poles of the batteries and do not try to recharge the batteries with power supply units other than those provided with the equipment.
- 27) Do not throw exhausted batteries into containers for other waste but dispose of them in the appropriate containers to enable them to be recycled. Disposal costs have already been paid for by the manufacturer.
- 28) Maintenance: check at least every 6 months the efficiency of the system, particularly the efficiency of the safety devices (including, where foreseen, the operator thrust force) and of the release devices.
- 29) **Anything not expressly specified in these instructions is not permitted.**

## Notes on work batteries

The battery supplied is a **WORK BATTERY** which directly powers the automated system.

***It is not a back-up battery.***

The battery is recharged by the MASTER-B or SLAVE-B control board to which it is connected via the transformer and a specific integrated circuit. Bear in mind that it takes about 10 to 20 minutes of recharging to recover the energy used during an opening/closing cycle (this value varies according to operating ambient temperature, battery life and type of system).

At installation, the batteries, due to storage, may not be fully charged and thus enable the gate to operate only a few times before discharging completely. That is why, before installing a new system, we recommend to fully charge the supplied batteries, or provide at least two identical fully charged batteries. In this way, you will be able to carry out the system programming operations and run the functional checks.

### HOW TO CHARGE THE BATTERIES FOR THE FIRST TIME

Charging can be done directly at the bench before the system is installed. Follow the instructions referring to the figure below:

- 1) connect the SLAVE-B board (connector J2) to the MASTER-B board (terminals 6-15);
- 2) connect the secondary winding of the 12Vac transformer (supplied separately) to connector J2 of the MASTER-B board and the primary winding to mains voltage;
  - Note:** if not using the transformer supplied by FAAC, make sure that the secondary winding is 12Vac - 16VA.
- 3) connect the batteries to the J4 connectors on the MASTER-B / SLAVE-B boards and allow them to charge for about 12 hours.

**NOTE:** While the batteries are being charged, LED P of the MASTER-B/SLAVE-B boards (see Fig. 15 and para.12.2) may change from fast flashing light (a flash about every 250msec means the battery is discharged) to steady light (battery charged). Even if the LED stays lighted steady a little while after you start charging, leave the batteries connected for the whole of the indicated time.

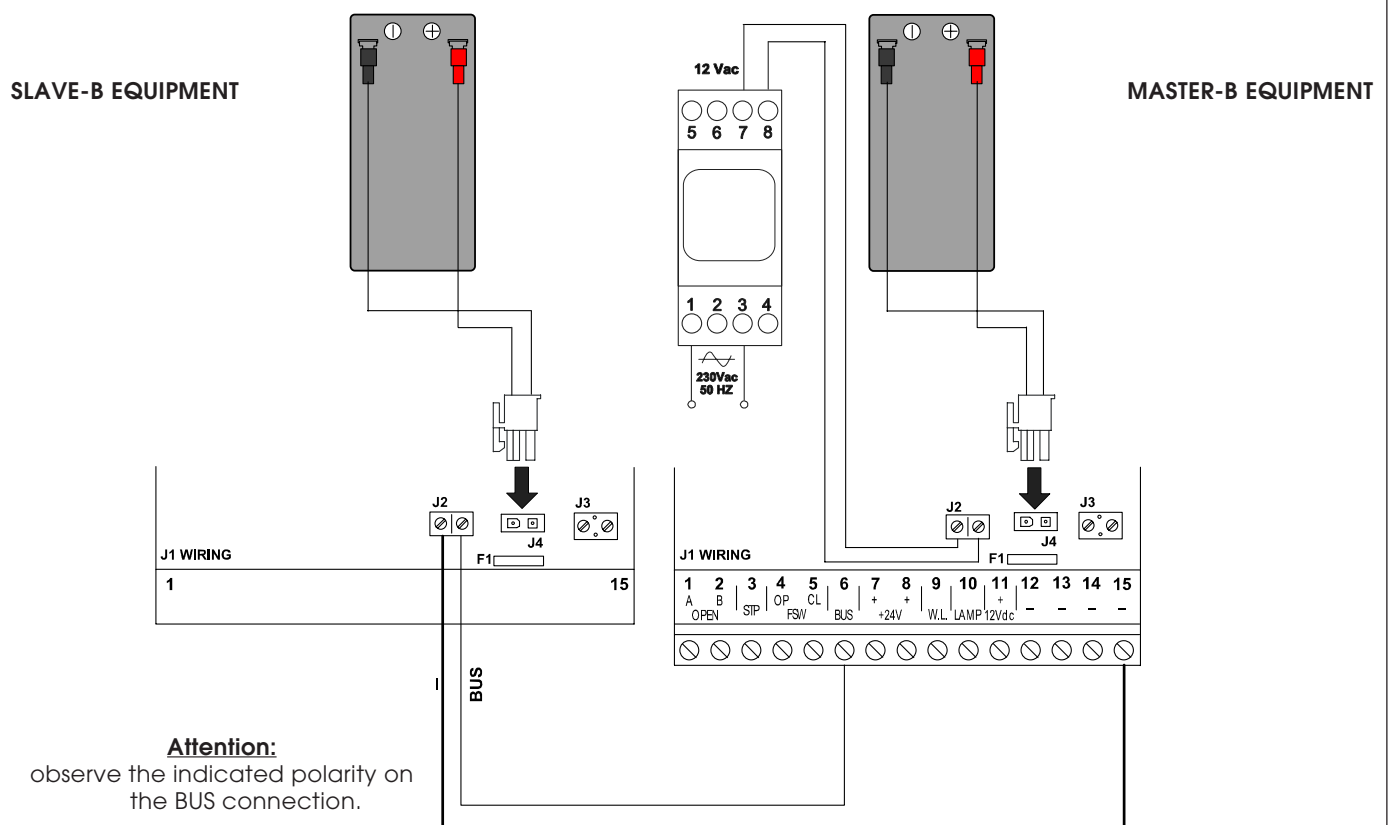

## MASTER-B AND SLAVE -B CONTROL BOARDS

These instructions apply to the following model:

### MASTER-B AND SLAVE-B CONTROL BOARDS FOR DOMO SWING AUTOMATED SYSTEMS

The DOMO automated system consists of non-reversing electro-mechanical linear operators, powered by a 12Vdc work battery, each coupled to a control board recharging the battery.

The SLAVE-B equipment (required on 2-leaf gates only) is controlled by the MASTER-B equipment to which all accessories and pulse generators are connected. The MASTER-B board can be programmed and is used to set the following: function logics, work times (by self-learning) and pause times, leaf speed, and the sensitivity of the anti-crushing device.

The non-reversing system guarantees the gate will automatically lock when the motor is not operating. A release system enables the gate to be moved by hand in case of malfunction.

The DOMOSWING automated system was designed and built for controlling vehicle access. Do not use for any other purpose.

### 1. DESCRIPTION AND TECHNICAL SPECIFICATIONS

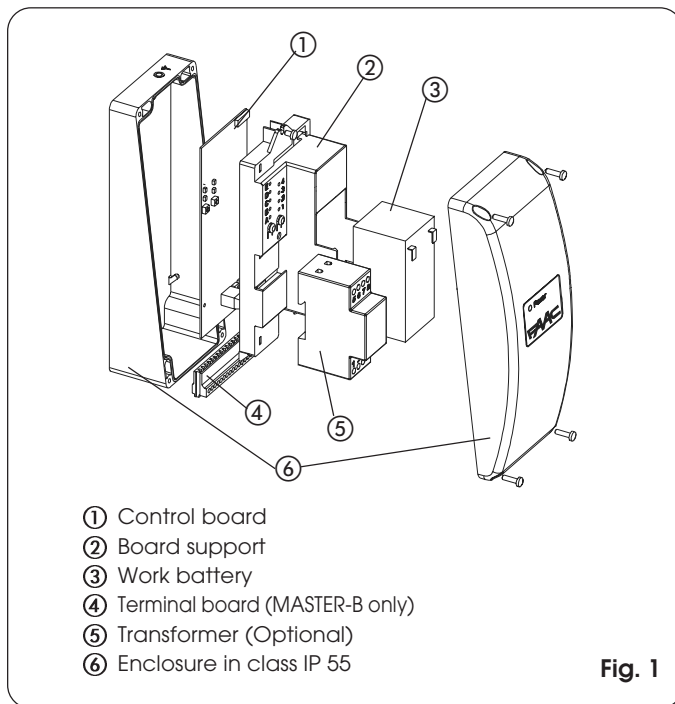

### 2. DIMENSIONS

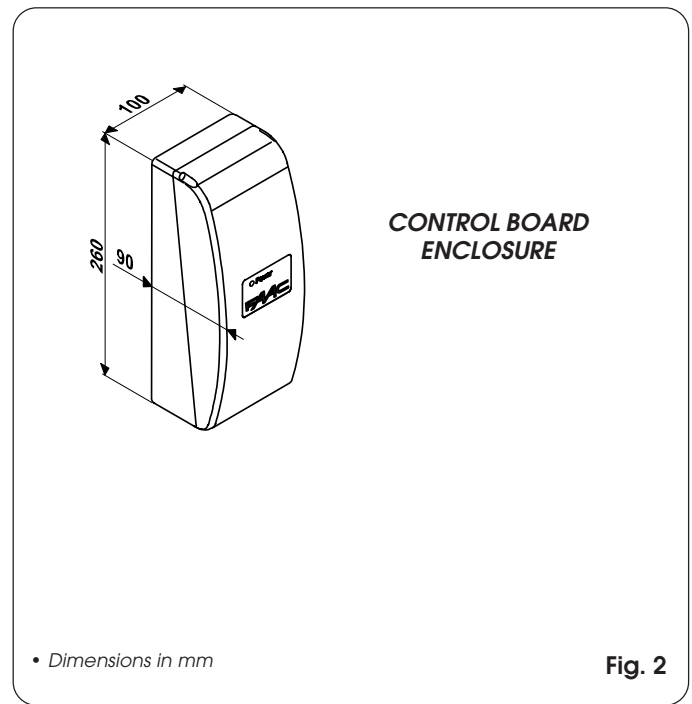

### 3. MASTER-B CARD TECHNICAL SPECIFICATIONS

<b>Power supply</b>	12Vac
<b>Transformer characteristics</b>	Primary 230 Vac~50/60Hz - Secondary 12 Vac - 16VA
<b>Accessories max. load at 24 Vdc</b>	150 mA
<b>Rapid connector max load</b>	50 mA
<b>Function logics</b>	Automatic / "Stepped" Automatic / Safety device / "Stepped" semi-automatic
<b>Opening/closing time</b>	By self-learning
<b>Pause time</b>	Programmable: 5, 10, 20, 30 sec.
<b>Leaf delay time when opening and closing</b>	(op 0s, cl 0s) - (op 2s, cl 2s) - (op 2s, cl 4s) - (op 2s, cl 8s)
<b>Speed</b>	Selectable on 4 levels
<b>Static force adjustment</b>	Selectable on 4 levels
<b>Terminal board inputs</b>	Open - Open released leaf Stop - Safety devices at opng. - Safety devices at clsnq.
<b>Terminal board outputs</b>	Flashing lamp - Motor - Bus - indicator-light - Accessories 24 Vdc - 12 Vdc power supply
<b>Rapid connector</b>	Minidec cards - RP cards
<b>Programmable functions</b>	Logic - pause time - leaf opening and closing delay - anti-crushing force - operators speed

### 4. SLAVE-B CARD TECHNICAL SPECIFICATIONS

<b>Power supply</b>	from Master-B
<b>Terminal board outputs</b>	Motor
<b>Terminal board inputs</b>	Battery - Bus

### 5. MASTER-B AND SLAVE-B CARDS COMMON CHARACTERISTICS

<b>Batteries</b>	hermetic Pb 12Vdc 1.2Ah - dimensions 96x46x50
<b>Use frequency (cycles/hour)</b>	5 (1)
<b>Consecutive cycles</b>	~15 (1)
<b>Battery recharge time</b>	~10' for each completed cycle (1)
<b>Enclosure protection class</b>	IP 55
<b>Motor max current</b>	15A
<b>Operating ambient temperature</b>	-20°C ÷ +55°C
<b>Protection fuses</b>	N° 1 - 20A
<b>Anti-crushing function</b>	Encoder - Current control

(1) The 5 cycles/hour are just a reference value for maintaining full efficiency of batteries. 15 consecutive cycles can be averagely performed with charged battery. The recovery time (battery recharge) is approx. 10' each cycle performed. The consecutive cycles could be reduced by over 50% at low temperatures (< 0°C).

6. DESCRIPTION OF SYSTEM - ELECTRICAL EQUIPMENT (standard system)

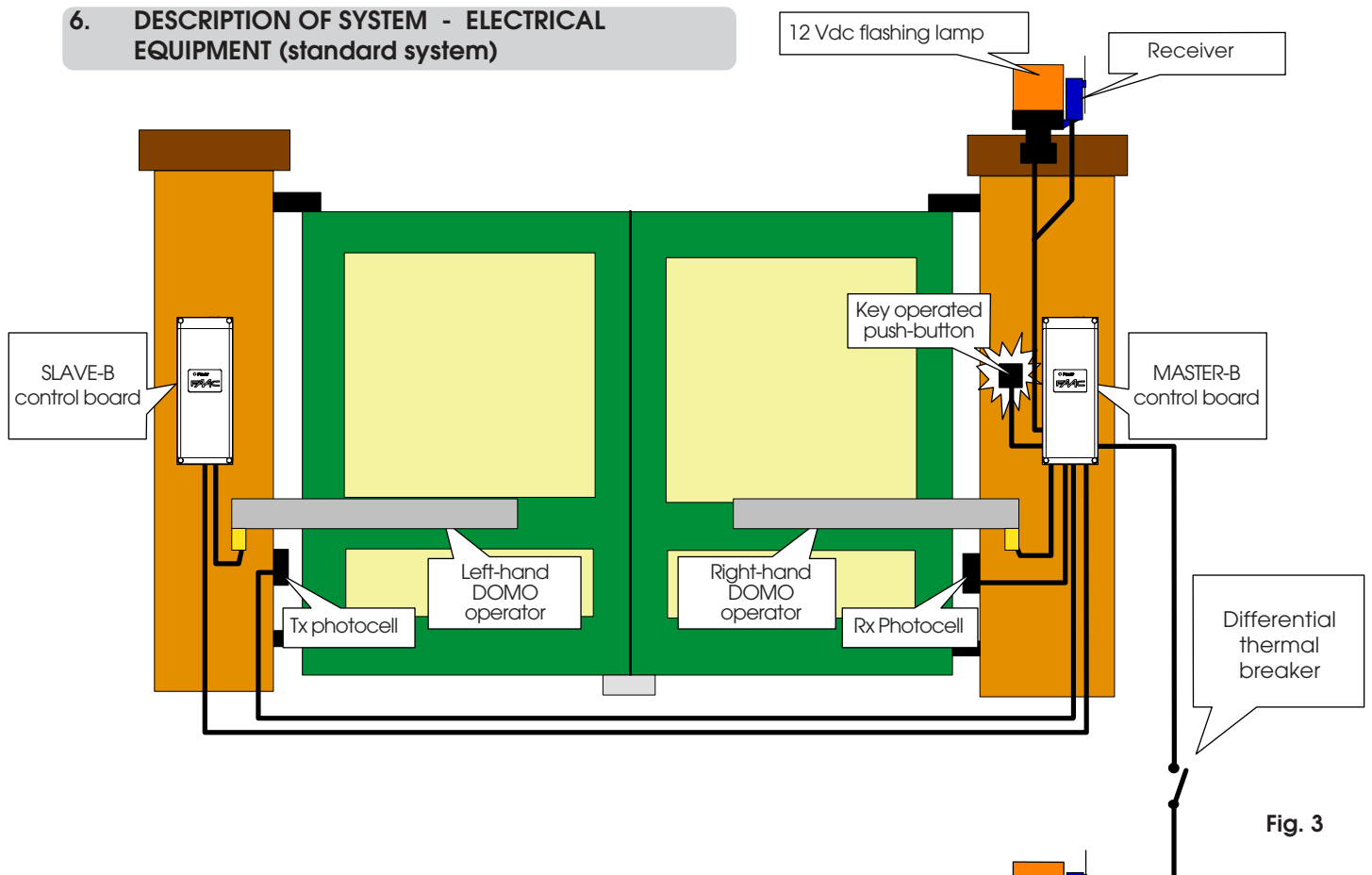

Fig. 3

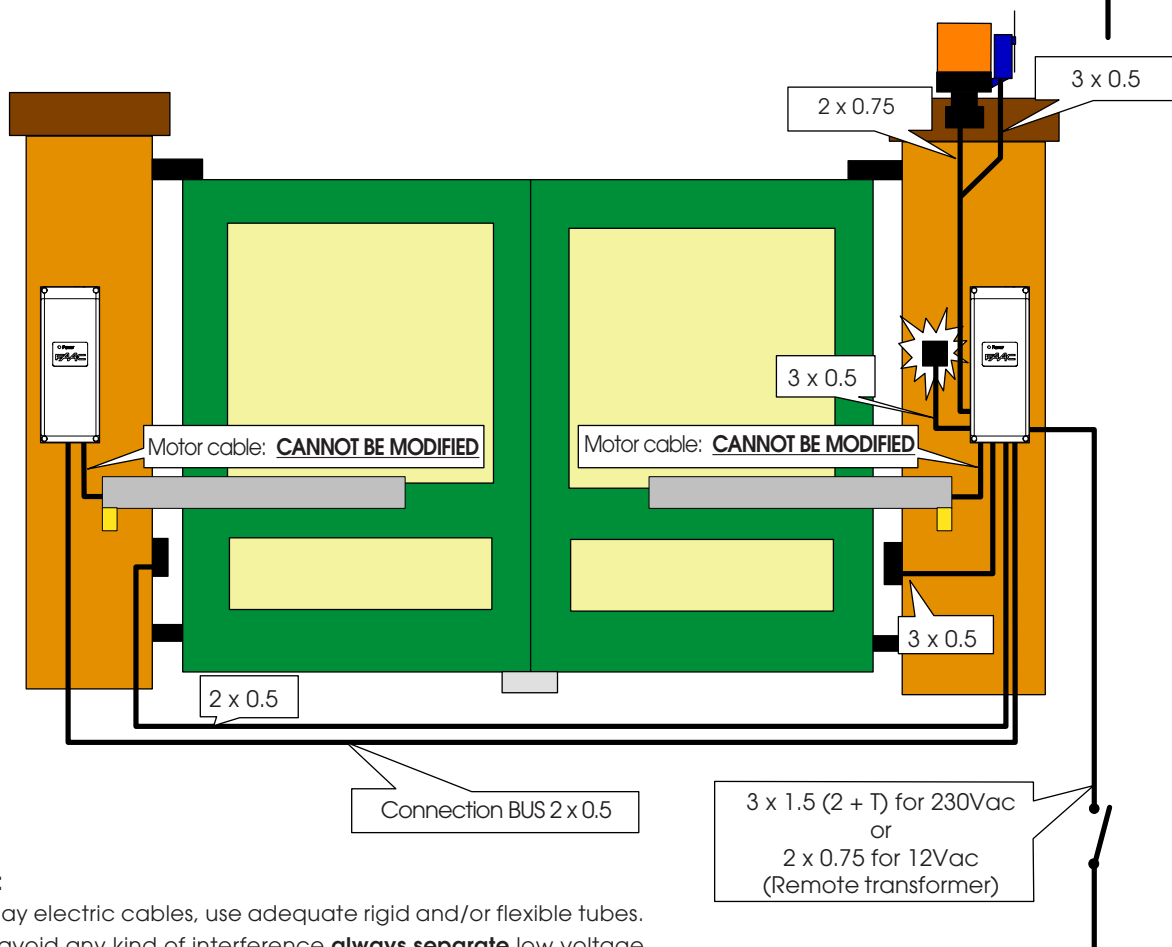

Fig. 4

Notes:

- 1) To lay electric cables, use adequate rigid and/or flexible tubes.
- 2) To avoid any kind of interference **always separate** low voltage connection cables from 230Vac power cables.
- 3) The transformer can be remotely located up to a distance of 100 m from the unit.
- 4) See chpt. 7 for installation of boards enclosures.

## 7. INSTALLING THE CONTROL BOARD ENCLOSURE

The MASTER-B board positioning has to be decided before installing the control board enclosures since all accessories will be connected to this board.

The MASTER-B board can be fitted either on the right or on the left side of the gate. You only have to decide to which leaf it will be associated as shown in Fig. 5.

In double-leaf applications, the MASTER-B board always commands leaf 1. If you wish to command leaf 1 with the SLAVE-B board, and leaf 2 with the MASTER-B board, you have to program the system in the appropriate way. (refer to chapter 12.4.1).

**NB.:** Leaf 1 is always the leaf that starts first on opening and is delayed on closing.

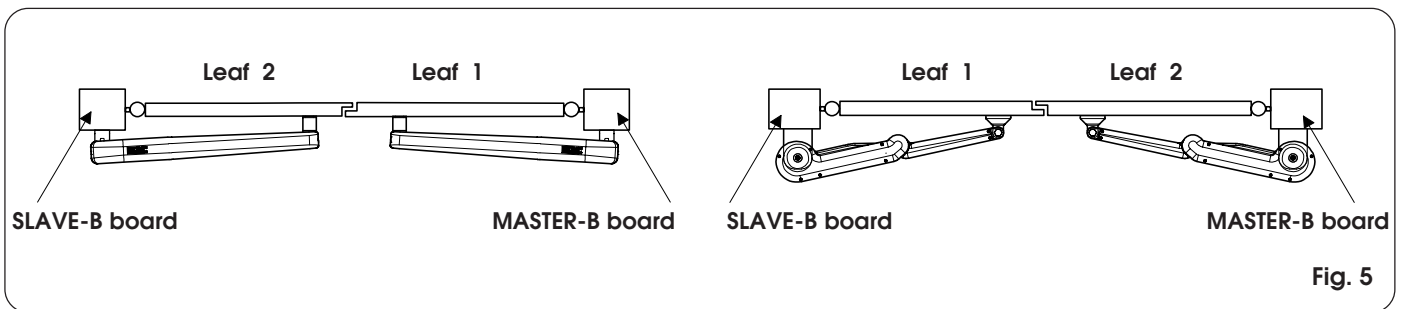

Fig. 5

Install the enclosures of the MASTER-B control board (to which all accessories and pulse generators will be connected) and the SLAVE-B units near the DOMO operators using 4 expansion bolts and their fixing screws. Route the electric cables to the bottom of the box using adequate rigid and/or flexible tubes and proper joints (Fig. 6).

Leave the cables inside the enclosure lengthy enough to enable you to wire up.

**NOTE:**

TO ENSURE CORRECT OPERATION OF THE SYSTEM, DO NOT, FOR ANY REASON, EXTEND OR MODIFY THE OPERATOR CABLES.

BEAR THIS IN MIND BEFORE INSTALLING THE ENCLOSURES.

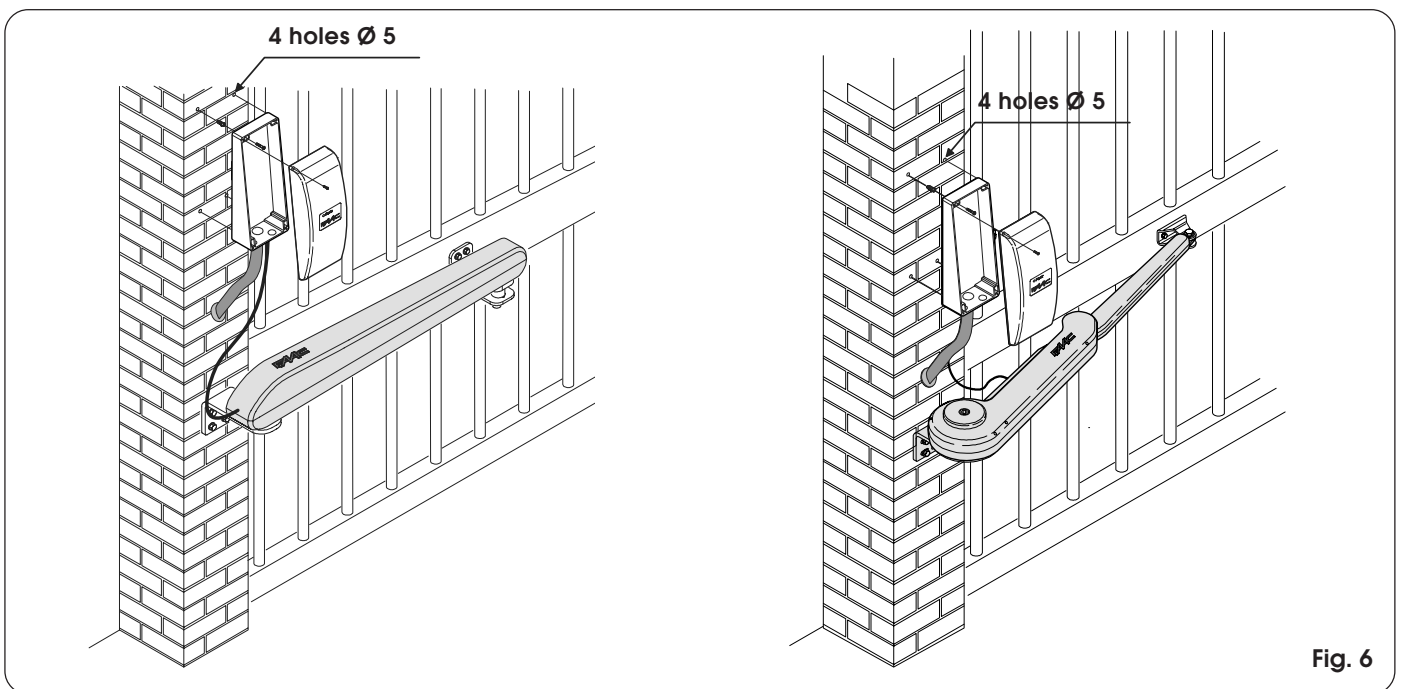

Fig. 6

**8. WARNINGS**

Attention: Before attempting any job on the control board (connections, maintenance), cut out electric power and the battery.

-Install, upstream of the system, a differential thermal breaker with adequate tripping threshold.

-Always separate 230VAC power cable from control and safety cables (push-buttons, receiver, photocells, etc.). To avoid any electric noise, use separate sheaths or a shielded cable (with earthed shield).

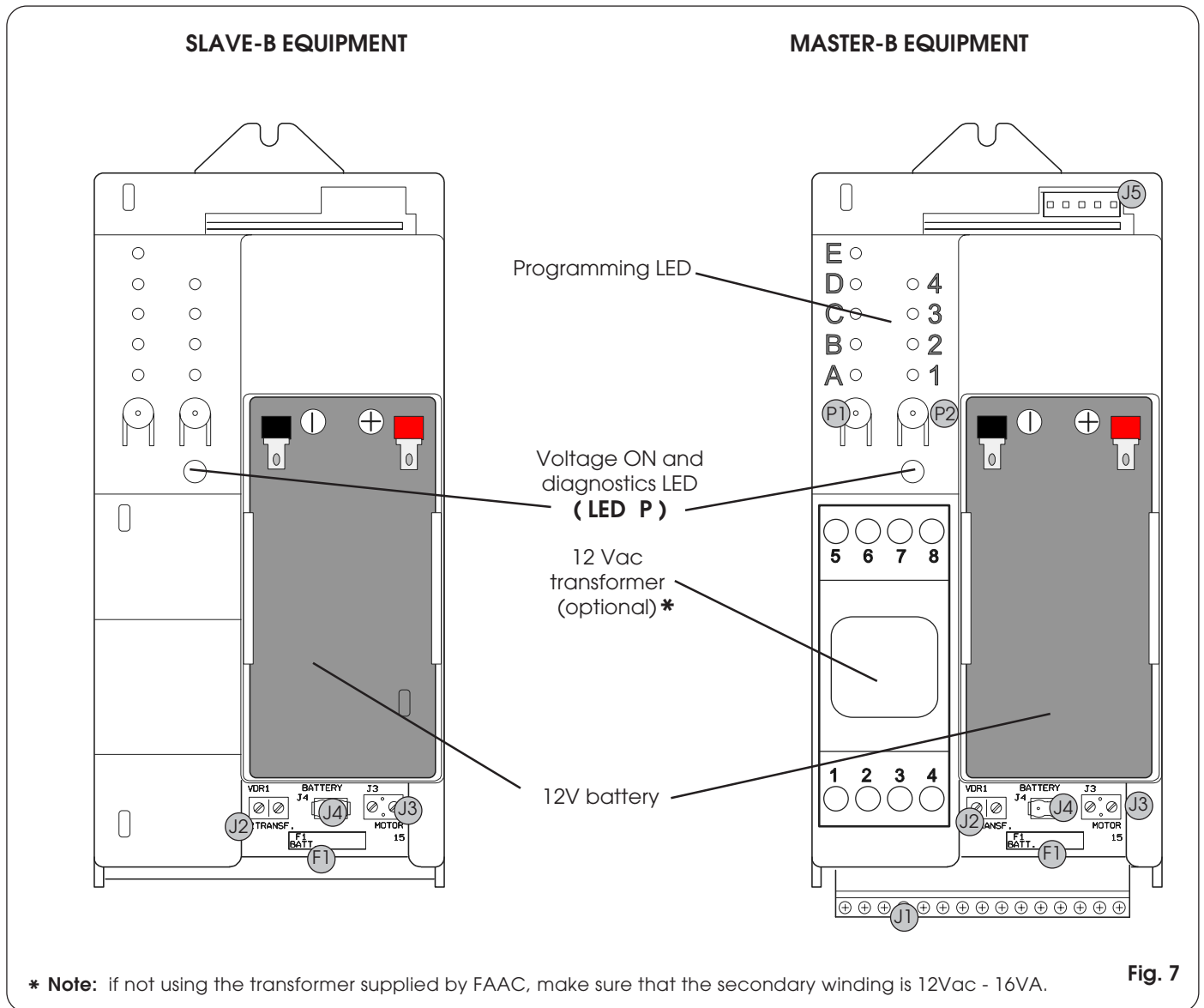

**9. SLAVE-B BOARD LAYOUT**

J1, J5, P1, P2 and LED are not present on the SLAVE-B board, and the other elements have the following functions.

<b>F1</b>	Battery and motor fuse F20A
<b>J2</b>	Bus connection terminal board
<b>J3</b>	Motor connection terminal board
<b>J4</b>	Battery connector

**10. MASTER-B BOARD LAYOUT**

<b>P1</b>	Programming push-button: "Function"
<b>P2</b>	Programming push-button: "Value"
<b>F1</b>	Battery and motor fuse F20A
<b>J1</b>	Accessories terminal board
<b>J2</b>	Transformer terminal board
<b>J3</b>	Motor connection terminal board
<b>J4</b>	Battery connector
<b>J5</b>	Minidec/RP Receiver connector

**11. ELECTRICAL CONNECTIONS**

Wire up as shown in Fig. 8

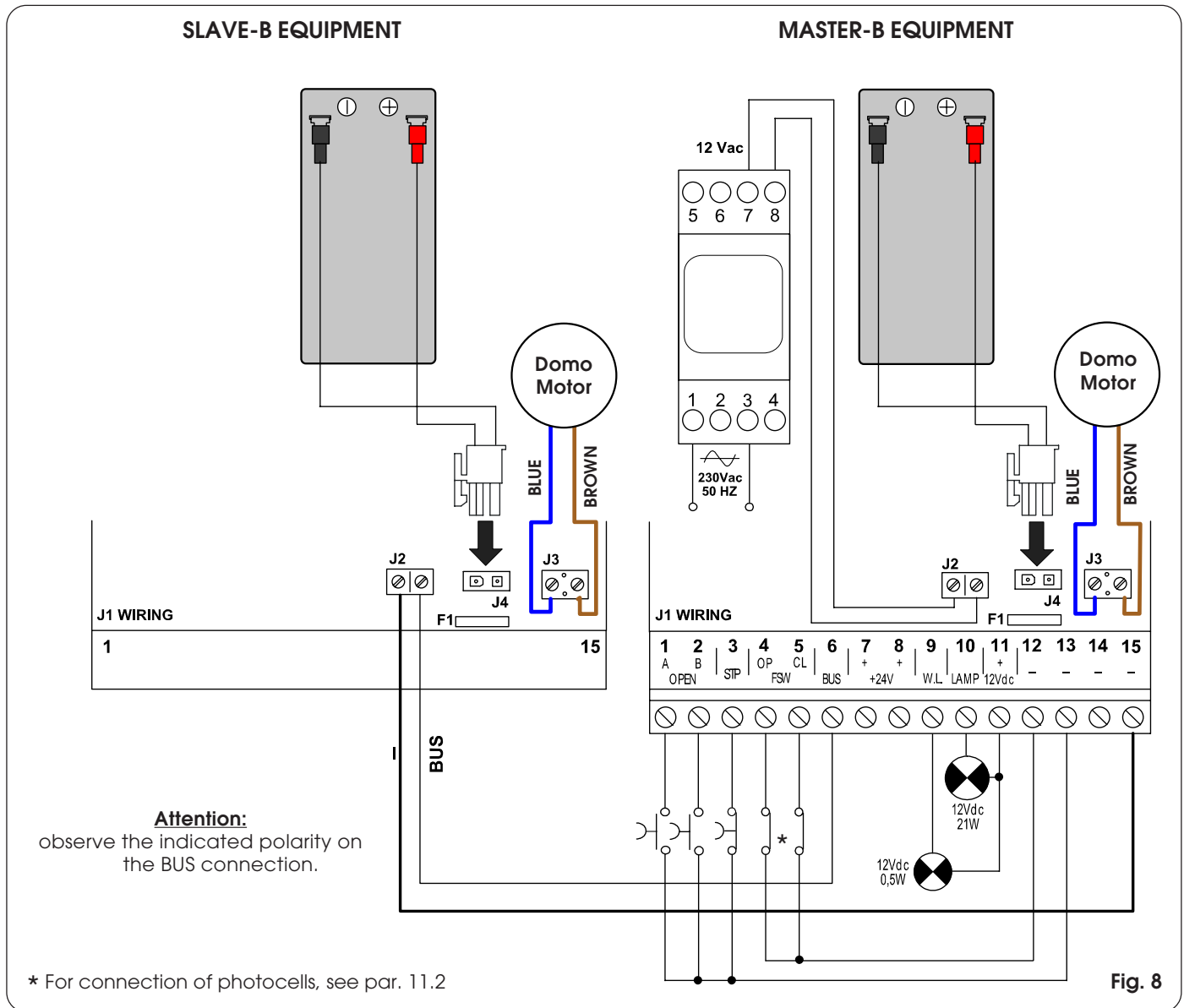

**11.1 Description of J1 terminal board**

**Tab. 1** - Description of accessories connection

Terminal	Description	Connected accessory
1	OPEN A (opening command for leaves 1 and 2)	Device with NA contact (e.g. key operated push-button)
2	OPEN B (opening command for leaf 1)	Device with NA contact (e.g. key operated push-button)
3	STOP (gate lock command)	Device with NC contact. <b>(1)</b>
4	FSW OP (Opening safety devices contact)	Photocells (e.g. SAFEBEAM) <b>(1)</b>
5	FSW CL (Closing safety devices contact)	Photocells (e.g. SAFEBEAM) <b>(1)</b>
6	BUS (MASTER-B - SLAVE-B connection)	/
7 - 8	+ (positive for 24V power supply)	Accessories MAX total absorption of 150mA
9 - 11	W.L. (Power supply to indicator light)	12V - 0.5W lamp
10 - 11	LAMP (Power supply to flashing lamp)	FAACLIGHT 12V flashing lamp
12 ÷ 15	- (negative for 24Vdc power supply)	/

**(1)** If you are not using any accessories, connect the terminal to earth (terminals 12 - 15).

**Note:** when the automated system is idle, the power supply (+24 V) to accessories is disabled.

**11.2 Connection of photocells and safety devices**

Before connecting the photocells (or other devices) we advise you to select the type of operation according to the movement zone to be protected (see Fig.9).

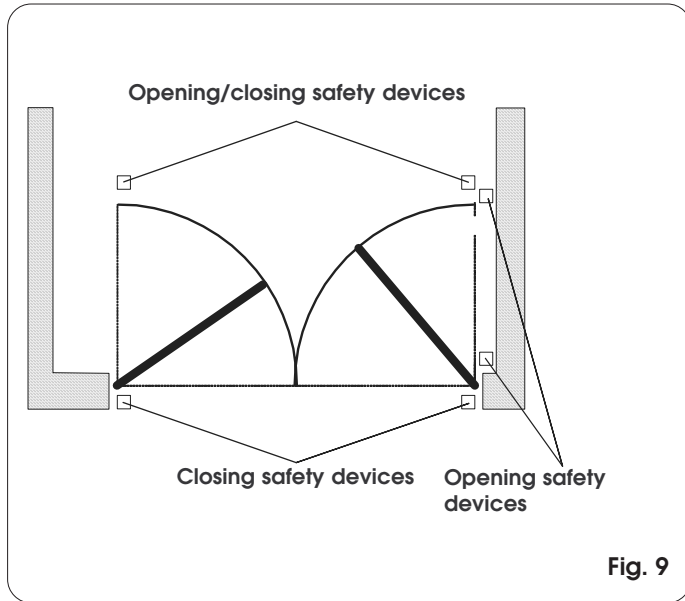

**Fig. 9**

**N.B.:** If two or more devices with N.C. contact have the same function, they must be connected to each other in series (Fig. 10).

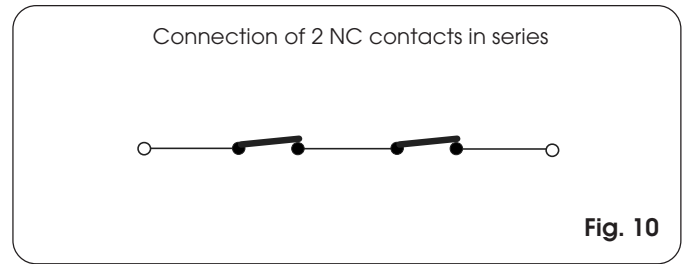

**Fig. 10**

**N.B.:** If two or more devices with N.A. contact have the same function, they must be connected to each other in parallel (Fig. 11).

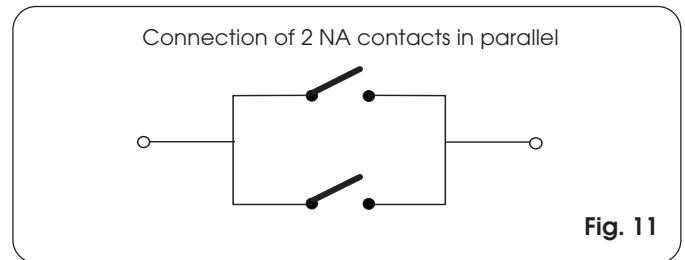

**Fig. 11**

**Attention:** a maximum of 2 pairs of SAFEBEAM photocells can be connected to the MASTER-B board

**Examples of photocell connections**

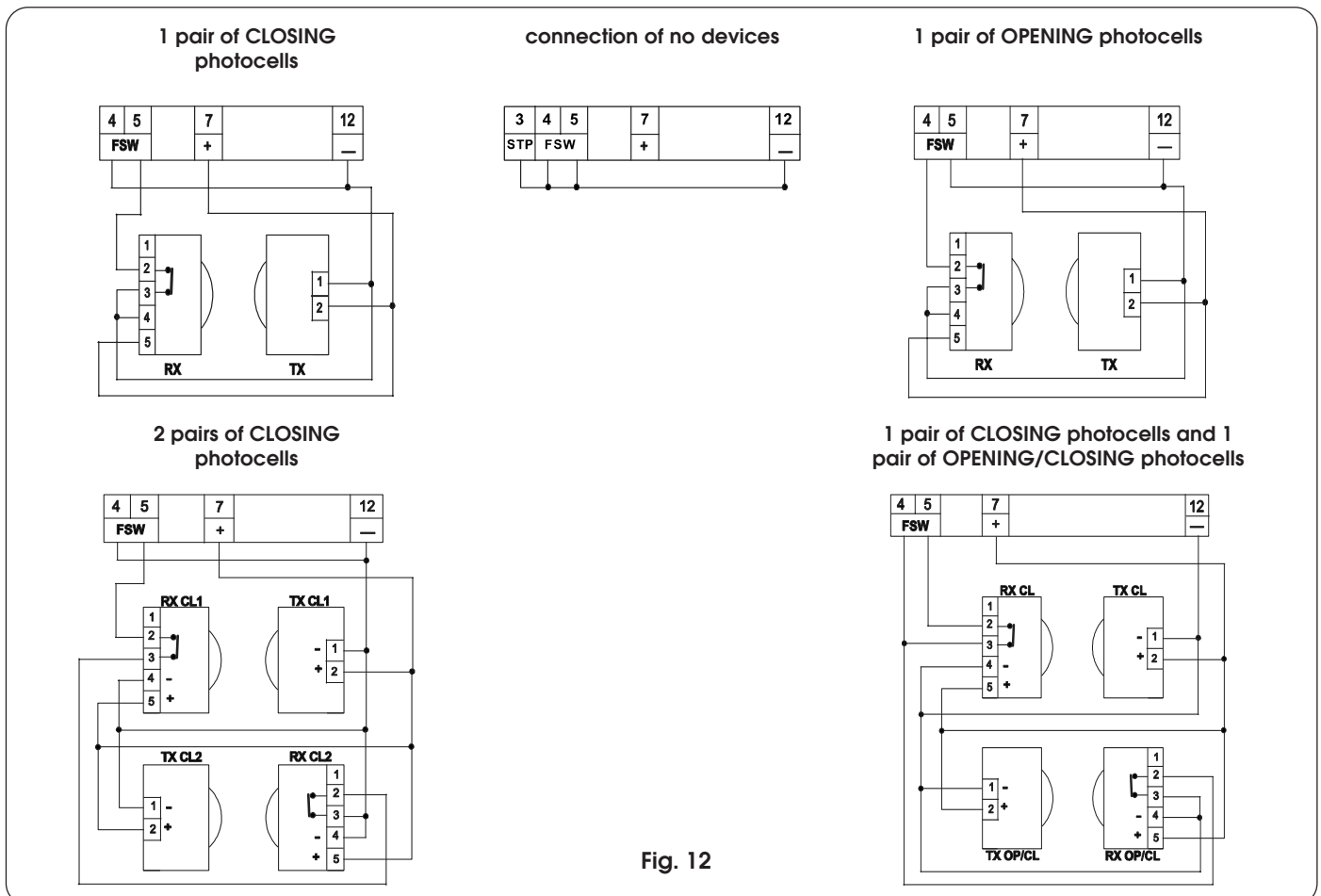

**Fig. 12**



**11.3 Connection of MINIDEC, RP cards**

Insert the MINIDEC or RP decoding card in the block connector J5 (Fig. 7), with the components facing up (Fig. 7 shows the connection of cards RP433DS).

For programming the decoding cards, consult the individual instructions.

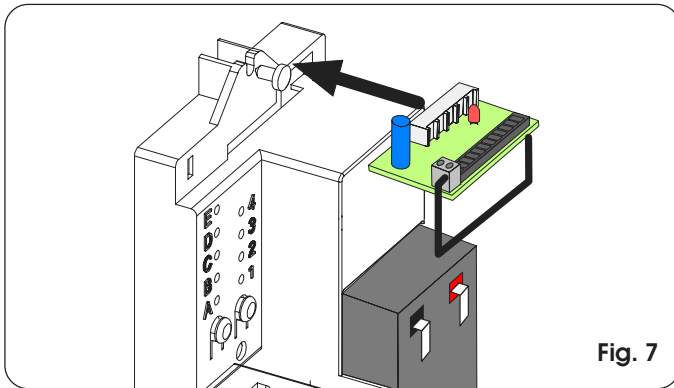

**12. START-UP**

**12.1 Powering up the system**

After making all the cable connections we described previously, power up the system to enable diagnostics, check of inputs status and programming.

**12.2 Diagnostics**

LED "P" (see Fig.7) - visible from outside the enclosure - performs the diagnostics function. The LED has 4 statuses:

**Tab. 2** - Description of LED P status

Steady light	Mains power present and battery charged.
Slow flashing (lights every second)	Mains power not supplied for not more than 5 minutes, with battery charged. When mains power returns, the LED stays lighted steadily. If mains power is still not supplied, the LED goes off (SLEEP mode).
Rapid flashing (lights every 250 msec)	Mains power present and battery discharged ( <i>gate locked</i> ). The LED continues to flash rapidly until the battery has recharged sufficiently. If mains power is not supplied, the LED goes off (SLEEP mode).
Light OFF	No mains power supplied (SLEEP mode).

**Note:** in the SLEEP mode, an OPEN pulse is sufficient to move the gate (with charged battery)

**12.3 Status of inputs**

The MASTER-B board has a function for checking the status of inputs on the terminal board.

In all LEDS OFF status (LEDs both with letters and numbers), press the P2 push-button.

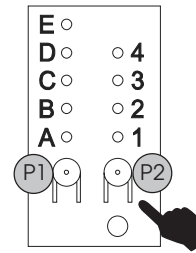

When the LEDs light up, this indicates the inputs status as shown in Tab. 3.

**Tab. 3** - Description of inputs status LEDs

LEDs	Lighted (closed contact)	Off (open contact)
A = Open A	Command active	<b>Command inactive</b>
B = Open B	Command active	<b>Command inactive</b>
C = Stop	<b>Command inactive</b>	Command active
D = Fsw op	<b>Safety devices disengaged</b>	Safety devices engaged
E = Fsw cl	<b>Safety devices disengaged</b>	Safety devices engaged
1 = SLAVE-B	<b>SLAVE-B present and active</b>	SLAVE-B absent or inactive

**Notes:**

- The status of LEDs with the gate closed at rest is shown in **bold**.
- LED 1 is active only when the MASTER-B and SLAVE-B boards communicate in systems with double-leaf gates and with the SLAVE-B battery charged.
- In the inputs status function, push-button P1 commands an OPEN A.

When checks have finished, once again press push-button P2 to exit the inputs status function.

**12.4 Programming**

These are the basic settings of the MASTER-B board:

MASTER-B board	<b>LEAF 1</b>
Function logic:	<b>A4</b>
Pause times:	<b>B1</b>
Opening/closing delay:	<b>C3</b>
Static force:	<b>D3</b>
Speed:	<b>E2</b>

If you wish to execute customised programming (see par. from 12.4.1 to 12.4.6) and time-learning (see par. 12.4.7 and 12.4.8) follow the steps in the next pages.

**12.4.1 Leaf 1 management with MASTER-B or SLAVE-B board**

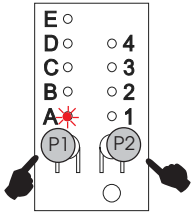

In all LEDs OFF status, press and hold down push-button P1, and press push-button P2 - LED A begins to flash.

Using push-button P2, move from LED 1 to LED 2 according to the type of leaf management you require, as described below.

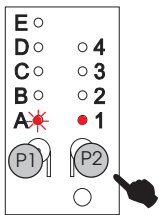

MASTER-B commands leaf 1 (Default).

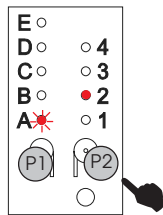

MASTER-B commands leaf 2

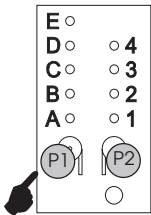

Press push-button P1 again to exit.

**12.4.2 Function Logic**

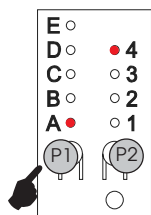

In all LEDs OFF status, press push-button P1. Led A will light up together with LED 4.

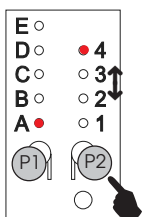

Press push-button P2, for a choice of 4 different function logics.

- A1 automatic
- A2 safety
- A3 Step-by-step automatic
- A4 Step-by-step semi-automatic (default)

**12.4.3 Pause Times**

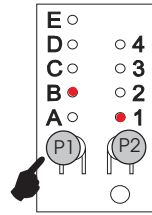

Press push-button P1 again and LED B will light together with LED 1.

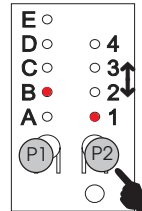

Press push-button P2, for a choice of 4 different pausetimes.

- B1 5 seconds (default)
- B2 10 seconds
- B3 20 seconds
- B4 30 seconds

**12.4.4 Opening/Closing Delay**

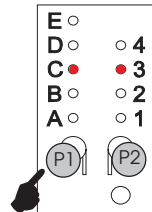

Press push-button P1 again and LED C will light together with LED 3.

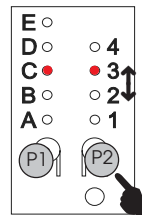

Press push-button P2, for a choice of 4 different delays.

- C1 op. 0 sec / cl. 0 sec
- C2 op. 2 sec / cl. 2 sec
- C3 op. 2 sec / cl. 4 sec (default)
- C4 op. 2 sec / cl. 8 sec

**12.4.5 Static Force**

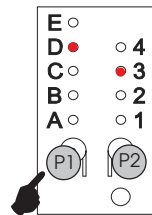

Press push-button P1 again and LED D will light together with LED 3.

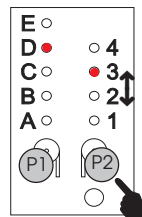

Press push-button P2, for a choice of 4 different static forces.

- D1 low
- D2 medium low
- D3 medium high (default)
- D4 high

**12.4.6 Speed**

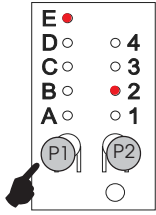

Press push-button P1 again and LED E will light together with LED 2.

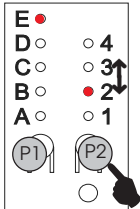

Press push-button P2, for a choice of 4 different speeds

- E1 low
- E2 medium low (default)
- E3 medium high
- E4 high

**12.4.7 Simple learning**

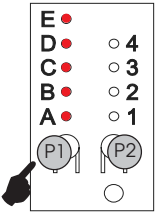

If you press push-button P1 again, all 5 LEDs from A to E will light.

(Make sure that the gate is closed and operators locked)

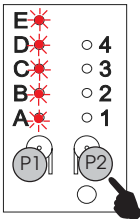

If you press push-button P2 for 1 second, the MASTER-B leaf and the SLAVE-B leaf will begin to move together until the opening mechanical stop-point is reached. The 5 LEDs flash during this stage. After learning has been completed, the 5 LEDs remain lighted steadily.

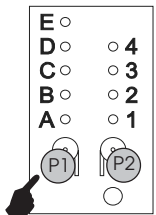

Press push-button P1 again to exit (all LEDs OFF). Give a pulse with the radio control to close the gate.

**12.4.8 Complete learning**

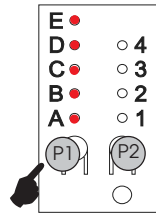

If you press push-button P1 after setting the speed, all 5 LEDs from A to E will light.

(Make sure that the gate is closed and operators locked)

If you press push-button P2 for more than 3 seconds, leaf 1 begins to move. You can command the following functions with subsequent pulses from P2 (or by key-operated push button or radiocontrol):

*1<sup>st</sup> pulse* - leaf 1 opening deceleration starts.

Allow leaf 1 to reach its stop-point and when it is still, leaf 2 opening movement begins. **(1)**

*2<sup>nd</sup> pulse* - leaf 2 opening deceleration starts.

Allow leaf 2 to reach its stop-point and when it is still, leaf 2 closing movement begins. **(1)**

*3<sup>rd</sup> pulse* - leaf 2 closing deceleration starts and when the leaf has reached its stop-point, the leaf 1 closing movement begins.

*4<sup>th</sup> pulse* - leaf 1 closing deceleration starts - allow leaf 1 to reach its stop-point.

The 5 LEDs flash during this stage.

**Note (1):** if you have no opening mechanical stop-points, give the stop command at the required point with a further pulse from P2.

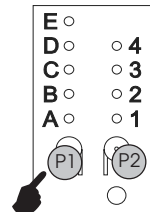
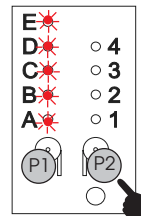

Press push-button P1 again to exit when learning has finished (all LEDs OFF).

### 12.5 Status of indicator light

If you wish to use a 12V-0.5W indicator light (terminal 9 - 11 of J1, see Fig. 8), the following table shows the statuses of the indicator light according to gate position.

**Tab. 4** - Statuses of indicator light

Indicator-light status	Gate status
Light Off	Closed
Lighted	Open - Open in pause
Flashing	Closing
Lighted	Opening
Lighted	Locked

### 12.6 Testing the automated system

After programming, run an accurate functional check of the automated system and of all the accessories connected to it, especially the safety devices.

## 13 MAINTENANCE

Carry out the following jobs at least every 6 months:

- Check if the anti-crushing facility is correctly set.
- Check the efficiency of the release system.
- Check the efficiency of the safety devices and accessories.

## 14. REPAIRS

For any repairs, contact authorised Repair Centres.

Table 5/a

LOGIC "A"					PULSES		
GATE STATUS	OPEN-A	OPEN B	STOP	OPENING SAFETY DEVICES	CLOSING SAFETY DEVICES	OP/CL SAFETY DEVICE	
CLOSED	Opens leaf/ves and re-closes after pause time		No effect (OPEN disabled)	No effect	No effect	No effect (OPEN disabled)	
OPEN on PAUSE	Reloads pause time		Stops operation	No effect	Reloads pause time		
CLOSING	Re-opens the leaf/ves immediately			No effect	Immediately reverses to open	Locks and, on release, reverses at opening	
OPENING	No effect			Immediately reverses to close	No effect	Locks and, on release, continues opening	
LOCKED	Closes the leaf/ves		No effect	No effect	No effect (OPEN disabled)		

Table 5/b

LOGIC "S"					PULSES		
GATE STATUS	OPEN-A	OPEN B	STOP	OPENING SAFETY DEVICES	CLOSING SAFETY DEVICES	OP/CL SAFETY DEVICE	
CLOSED	Opens leaf/ves and re-closes after pause time		No effect (OPEN disabled)	No effect	No effect	No effect (OPEN disabled)	
OPEN on PAUSE	Re-closes the leaf/ves immediately		Stops operation	No effect	Closes after 5" (OPEN disabled) on release		
CLOSING	Re-opens the leaf/ves immediately			No effect	Immediately reverses to open	Locks and, on release, reverses at opening	
OPENING	Re-closes the leaf/ves immediately			Immediately reverses to close	No effect	Locks and, on release, continues opening	
LOCKED	Closes the leaf/ves		No effect	No effect	No effect (OPEN disabled)		

Table 5/c

LOGIC "AP"					PULSES		
GATE STATUS	OPEN-A	OPEN B	STOP	OPENING SAFETY DEVICES	CLOSING SAFETY DEVICES	OP/CL SAFETY DEVICE	
CLOSED	Opens leaf/ves and re-closes after pause time		No effect (OPEN disabled)	No effect	No effect	No effect (OPEN disabled)	
OPEN on PAUSE	Stops operation		Stops operation	No effect	Reloads pause time		
CLOSING	Re-opens the leaf/ves immediately			No effect	Immediately reverses to open	Locks and, on release, reverses at opening	
OPENING	Stops operation			Immediately reverses to close	No effect	Locks and, on release, continues opening	
LOCKED	Closes the leaf/ves		No effect	No effect	No effect (OPEN disabled)		

Table 5/d

LOGIC "EP"					PULSES		
GATE STATUS	OPEN-A	OPEN B	STOP	OPENING SAFETY DEVICES	CLOSING SAFETY DEVICES	OP/CL SAFETY DEVICE	
CLOSED	Opens leaf/ves		No effect (OPEN disabled)	No effect	No effect	No effect (OPEN disabled)	
OPEN	Re-closes the leaf/ves immediately		Stops operation	No effect	No effect (OPEN disabled)		
CLOSING	Stops operation			Immediately reverses to open	Immediately reverses to open	Locks and, on release, reverses at opening	
OPENING	Stops operation			Immediately reverses to close	No effect	Locks and, on release, continues opening	
LOCKED	After OPEN: Restarts moving in reverse direction After STOP: Re-closes the leaf/ves immediately		No effect (OPEN disabled)	No effect (if it must open, it disables OPEN)	No effect (OPEN disabled)		

**TROUBLESHOOTING**

<b>Fault</b>	<b>Possible causes</b>	<b>Solution</b>
MASTER-B and SLAVE-B board LED P OFF	No mains power supplied for more than 5 minutes with battery charged	Just give an OPEN pulse to move the gate.
	No mains power supplied with battery discharged	The gate will stay locked until mains power returns and the battery is sufficiently recharged.
Only one of the two leaves is moving.	The battery of the board associated with the idle leaf is discharged.	Allow the battery to recharge until the board's LED is on steady light.
	The fuse of the board associated with the idle leaf failed.	Check the fuses (F20A) and, if necessary, replace them.
Only the leaf associated with the MASTER-B board is moving, while the SLAVE-B board leaf is not moving.	BUS connection interrupted.	Check integrity of the BUS connection between the two boards.
	SLAVE-B battery discharged. (The SLAVE-B board LED flashes rapidly and LED 1 of the MASTER-B board on the inputs status is OFF).	Allow the SLAVE-B battery to recharge until the LED is on steady light.
Automated system shut down. It does not move by any command (radio control or key operated selector switch).	Discharged batteries	Check if LED P of the MASTER-B board is OFF or flashing rapidly. In the latter case, allow the batteries to recharge
	STOP (3) and FSW (4 and 5) terminals not connected.	Check the wiring as shown in the instructions and also check if LEDs C, D and E light correctly on the inputs status.
	Battery fuses failed.	Check the fuses (F20A) and, if necessary, replace them.
Automated system shut down. Moves only by key-operated command.	No mains power supplied for more than 24 hours.	The radio receiver is re-activated when mains power returns or by giving a pulse with the key-operated selector switch; in this case, if mains power does not return within the next 24 hours, the receiver is once again powered down.
	Faulty radio control	Using another radio control, check if the system is operating correctly and, if necessary, replace the faulty radio control.
	Faulty receiver board	If the automated system is still shut down even after checking that radio control was not faulty, replace the receiver board.
The automated system jams and/or jerks strangely on starting.	The motor has reached the mechanical travel limit.	Arrange the front and rear fittings as per specifications.
The leaves swing wildly at the start of their manoeuvre or when moving.	Speed of motors inadequate for gate.	Adjust the speed of the motors as accurately as possible, by entering the programming of the MASTER-B board.
Gate reaching the mechanical travel stops at full speed and reversing motion.	Insufficient closing/opening decelerations	Lengthen the decelerations by fully programming the automated system.
During movement, the automated system reverses motion for no reason.	Force too low (meeting an imaginary obstacle)	Check if there are any obstacles on the route of the leaves, such as stones or uneven asphalt, and increase the static force of the motors.
	Incorrect reading of Domo motor movement.	Make sure that the motor power cable was not extended or modified.