



FCC TEST REPORT

FCC Part 15 B

Report Number..... : ZKT-2311038374E

Date of Test..... Oct.27, 2023 to Nov.03, 2023

Date of issue..... : Nov.03, 2023

Total number of pages..... 16

Test Result : PASS

Testing Laboratory..... : **Shenzhen ZKT Technology Co., Ltd.**

Address : 1/F, No. 101, Building B, No. 6, Tangwei Community Industrial Avenue, Fuhai Street, Bao'an District, Shenzhen, China

Applicant's name : **SHENZHEN ITOONER TECHNOLOGY CO.,LTD**

Address : Building 2&Building 3(The 3rd and 4th Floor) Gangzai Road, Shangxing Community, Xinqiao Street, Baoan District, Shenzhen, Guangdong, China

Manufacturer's name : **SHENZHEN ITOONER TECHNOLOGY CO.,LTD**

Address : Building 2&Building 3(The 3rd and 4th Floor) Gangzai Road, Shangxing Community, Xinqiao Street, Baoan District, Shenzhen, Guangdong, China

Test specification:

Standard..... : FCC Part 15 B, ANSI C63.4:2014

Test procedure..... : FCC

Non-standard test method : N/A

Test Report Form No..... : TRF-EL-117_V0

Test Report Form(s) Originator..... : ZKT Testing

Master TRF : Dated: 2020-01-06

This device described above has been tested by ZKT, and the test results show that the equipment under test (EUT) is in compliance with the FCC requirements. And it is applicable only to the tested sample identified in the report.

This report shall not be reproduced except in full, without the written approval of ZKT, this document may be altered or revised by ZKT, personal only, and shall be noted in the revision of the document.

Product name..... : **PoE Switch**

Trademark : N/A

Model/Type reference..... : GNTP4804V6, Additional models See 3 page

Ratings..... : Input: AC 90-240V, 50-60Hz, 120W



Testing procedure and testing location:

Testing Laboratory.....: **Shenzhen ZKT Technology Co., Ltd.**

Address.....: 1/F, No. 101, Building B, No. 6, Tangwei Community Industrial Avenue, Fuhai Street, Bao'an District, Shenzhen, China

Tested by (name + signature).....: Jim Liu

Reviewer (name + signature).....: Jackson Fang

Approved (name + signature).....: Lake Xie



Additional Model(s)

: GNT-P9206EA, GNT-P9109EA, GNT-P9808V6, GNT-P9828V6, GNT-P1210SG, GNT-P4804V6, GNT-P4803V6, GNT-P4813V6, GNT-P4815V6, GNT-P9806V6, GNT-P1006G6, GNT-P1006GA, GNT-P1008G6, GNT-P1210G7, GNT-P1012G6, GNT-P1018G6, GNT-P1026G6, GNT-MP1420G6, GNT-RP1420G6, GNT-RP1428ES, GNT-RP1420ES, GNT-MP1420ES, GNT-P1614ES, GNT-P9206EB, GNT-RP1428G6, GNT-P5420GC, GNT-G5420GC, GNT-P5428GC, GNT-G5428GC, GNT-P1002M6, GNT-P1802M6, GNT-P2804M6, GNT-P0602FMI, GNT-G0602FMI, GNT-P1002FMI, GNT-G1002FMI, GNT-P1608FMI, GNT-G1608FMI, GNT-IG1008GP-AC, GNT-IG1008GP-DC, GNT-IG1008GL-AC, GNT-IG1008GL-DC, GNT-IG1210FP-DC, GNT-IG1210GF-DC, GNT-IG1210FP-AC, GNT-IG1210GF-AC, GNT-IG1218FP-DC, GNT-IG1218F8-AC, GNT-IG1218GF-DC, GNT-IG1218GF-AC, GNT-IG1218FP-AC, GNT-IG1226FP-DC, GNT-IG1226F8-AC, GNT-IG1226FP-AC, GNT-IG1226GF-DC, GNT-IG1226GF-AC, GNT-IG3210FP-AC, GNT-IG3210FP-DC, GNT-IG2210GF-AC, GNT-IP52130WS, GNT-IP52260WS, GNT-IP52520WS, GNT-P9206F6, GNT-P9109EA-F, GNT-P9808F6, GNT-P9828F6, GNT-P4804F6, GNT-P4803F6, GNT-P4813F6, GNT-P4815F6, GNT-P1008G6-F, GNT-P1012G6-F, GNT-69P31, GNT-69P51G6, GNT-69P62GH, GNT-6FP31, GNT-6FP51G6, GNT-53011, GNT-53003, GNT-P9109EA-F, GNT-5313AB, GNT-69P01, GNT-69P02, GNT-P9105ES, GNT-P9109ES, GNT-P9210ES, GNT-P1210ES, GNT-E9005EL, GNT-E9008EL, GNT-G1207FEL, GNT-G1005EL, GNT-G1008EL, GNT-G1018L, GNT-G1026L, GNT-P6428GC, GNT-MG9008T, GNT-RG9654GT, GNT-RG9428GT, GNT-P3428GC, GNT-MG1206XT, GNT-RP9654GT, GNT-RP9428GT, GNT-P6428GC, GNT-G5826FG, GNT-G2420GC, GNT-G2008GL, GNT-P2428GC, GNT-P2420GC, GNT-P1412G6, GNT-P1307G6, GNT-RG1125E, GNT-MG1125EL, GNT-RG1117EL, GNT-MG1117EL, GNT-G2008EL, GNT-G2005EL, GNT-P9XXXXX, GNT-P4XXXXX, GNT-P1XXXXX, GNT-69PXX, GNT-6FPXX, GNT-MPXXXX, GNT-RPXXXX, GNT-P54XXXX, GNT-G54XXXX, GNT-G24XXXX, GNT-IG32XX, GNT-IG33XX, GNT-EXXXX, GNT-MGXXXX, GNT-RGXXXX, GNT-RP94XXXX, GNT-RP96XXXX, GNT-P34XXXX



TABLE OF CONTENT

	Page
1.VERSION	5
2.GENERAL INFORMATION	6
2.1 Description of Device (EUT)	6
2.2 Tested System Details	6
2.3 Test Facility	6
2.4 MEASUREMENT UNCERTAINTY	6
2.5 Test Instrument Used	7
3.CONDUCTED EMISSION AT THE MAINS TERMINALS TEST	8
3.1 Block Diagram Of Test Setup	8
3.2 Test Standard	8
3.3 Power Line Conducted Emission Limit	8
3.4 EUT Configuration on Test	8
3.5 Operating Condition of EUT	8
3.6 Test Procedure	8
3.7 Test Result	8
4.RADIATION EMISSION TEST	11
4.1 Block Diagram of Test Setup	11
4.2 Test Standard	11
4.3 Radiation Limit	11
4.4 EUT Configuration on Test	11
4.5 Operating Condition of EUT	11
4.6 Test Procedure	11
4.7 Test Result	11
5.EUT PHOTOGRAPHS	14
6.EUT TEST PHOTOGRAPHS	16



1.VERSION

Report No.	Version	Description	Approved
ZKT-2311038374E	Rev.01	Initial issue of report	Nov.03, 2023



2.GENERAL INFORMATION

2.1 Description of Device (EUT)

EUT	:	PoE Switch
Trademark	:	N/A
Model Number	:	Gntp4804V6, Additional models See 3 page
Model Difference	:	Only for different model name
Power Supply	:	Input: AC 90-240V, 50-60Hz, 120W

2.2 Tested System Details

None.

2.3 Test Facility

Site Description

Name of Firm : Shenzhen ZKT Technology Co., Ltd.

Site Location : 1/F, No. 101, Building B, No. 6, Tangwei Community Industrial Avenue, Fuhai Street, Bao'an District, Shenzhen, China

FCC Test Firm Registration Number: 692225
Designation Number: CN1299
IC Registered No.: 27033

2.4 MEASUREMENT UNCERTAINTY

Where relevant, the following measurement uncertainty levels have been estimated for tests performed on the Product as specified in CISPR 16-4-2. This uncertainty represents an expanded uncertainty expressed at approximately the 95% confidence level using a coverage factor of $k=2$.

Test item	Value (dB)
Conducted Emission (150K-30MHZ)	3.20
Radiated disturbance30MHz-1000MHz	4.80



2.5 Test Instrument Used

Conducted emissions Test

Item	Kind of Equipment	Manufacturer	Type No.	Serial No.	Firmware Version	Last calibration	Calibrated until
1	LISN	R&S	ENV216	101471	N/A	Oct. 21, 2023	Oct. 20, 2024
2	LISN	CYBERTEK	EM5040A	E1850400149	N/A	Oct. 21, 2023	Oct. 20, 2024
3	Test Cable	N/A	C-01	N/A	N/A	Oct. 21, 2023	Oct. 20, 2024
4	Test Cable	N/A	C-02	N/A	N/A	Oct. 21, 2023	Oct. 20, 2024
5	Test Cable	N/A	C-03	N/A	N/A	Oct. 21, 2023	Oct. 20, 2024
6	EMI Test Receiver	R&S	ESCI3	101393	4.42 SP3	Oct. 21, 2023	Oct. 20, 2024
7	Triple-Loop Antenna	N/A	RF300	N/A	N/A	Oct. 21, 2023	Oct. 20, 2024
8	Absorbing Clamp	DZ	ZN23201	15034	N/A	Oct. 21, 2023	Oct. 20, 2024
9	EMC Software	Frad	EZ-EMC	Ver.EMC-CO N 3A1.1	N/A	\	\

Radiation emissions& Radio Test equipment

Item	Equipment	Manufacturer	Type No.	Serial No.	Firmware Version	Last calibration	Calibrated until
1	Spectrum Analyzer (9kHz-26.5GHz)	KEYSIGHT	9020A	MY55370835	A.17.05	Oct. 21, 2023	Oct. 20, 2024
2	Spectrum Analyzer (10kHz-39.9GHz)	R&S	FSV40-N	100363	1.71 SP2	Oct. 21, 2023	Oct. 20, 2024
3	EMI Test Receiver (9kHz-7GHz)	R&S	ESCI7	101169	4.32	Oct. 21, 2023	Oct. 20, 2024
4	Bilog Antenna (30MHz-1500MHz)	Schwarzbeck	VULB9168	N/A	N/A	Oct. 21, 2023	Oct. 20, 2024
5	Horn Antenna (1GHz-18GHz)	Agilent	AH-118	071145	N/A	Oct. 21, 2023	Oct. 20, 2024
6	Horn Antenna (15GHz-40GHz)	A.H.System	SAS-574	588	N/A	Oct. 21, 2023	Oct. 20, 2024
7	Loop Antenna	TESEQ	HLA6121	58357	N/A	Oct. 21, 2023	Oct. 20, 2024
8	Amplifier (30-1000MHz)	EM Electronics	EM330 Amplifier	060747	N/A	Oct. 21, 2023	Oct. 20, 2024
9	Amplifier (1GHz-26.5GHz)	Agilent	8449B	3008A00315	N/A	Oct. 21, 2023	Oct. 20, 2024
10	Amplifier (500MHz-40GHz)	全聚达	DLE-161	097	N/A	Oct. 21, 2023	Oct. 20, 2024
11	Test Cable	N/A	R-01	N/A	N/A	Oct. 21, 2023	Oct. 20, 2024
12	Test Cable	N/A	R-02	N/A	N/A	Oct. 21, 2023	Oct. 20, 2024
13	Test Cable	N/A	R-03	N/A	N/A	Oct. 21, 2023	Oct. 20, 2024
14	Test Cable	N/A	RF-01	N/A	N/A	Oct. 21, 2023	Oct. 20, 2024
15	Test Cable	N/A	RF-02	N/A	N/A	Oct. 21, 2023	Oct. 20, 2024
16	Test Cable	N/A	RF-03	N/A	N/A	Oct. 21, 2023	Oct. 20, 2024
17	D.C. Power Supply	LongWei	TPR-6405D	N/A	N/A	\	\
18	EMC Software	Frad	EZ-EMC	Ver.EMC-CO N 3A1.1	N/A	\	\
19	Turntable	MF	MF-7802BS	N/A	N/A	\	\
20	Antenna tower	MF	MF-7802BS	N/A	N/A	\	\



3.CONDUCTED EMISSION AT THE MAINS TERMINALS TEST

3.1 Block Diagram Of Test Setup

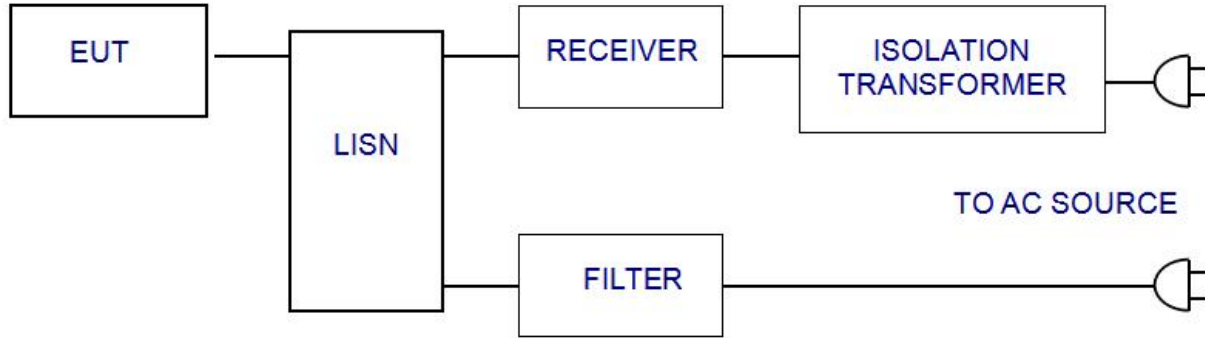

3.2 Test Standard

FCC PART 15 B

3.3 Power Line Conducted Emission Limit

Frequency MHz	Limits dB(μV)	
	Quasi-peak Level	Average Level
0.15 ~ 0.50	66 ~ 56*	56 ~ 46*
0.50 ~ 5.00	56	46
5.00 ~ 30.00	60	50

- Notes: 1. *Decreasing linearly with logarithm of frequency.
2. The lower limit shall apply at the transition frequencies.

3.4 EUT Configuration on Test

The following equipments are installed on conducted emission test to meet FCC PART 15 B requirement and operating in a manner which tends to maximize its emission characteristics in a normal application.

3.5 Operating Condition of EUT

- 3.5.1 Setup the EUT and simulators as shown in Section 3.1.
- 3.5.2 Turn on the power of all equipments.
- 3.5.3 Let the EUT work in test modes and test it.

3.6 Test Procedure

The EUT is put on the ground and connected to the AC mains through a Artificial Mains Network (AMN). This provided a 50ohm coupling impedance for the tested equipments. Both sides of AC line are checked to find out the maximum conducted emission levels according to the **FCC PART 15 B** regulations during conducted emission test.

The bandwidth of the test receiver (R&S Test Receiver ESCI) is set at 10KHz.

The frequency range from 150 KHz to 30 MHz is investigated.

3.7 Test Result

PASS

Please refer to the following page.



Conducted Emission At The Mains Terminals Test Data			
Temperature:	24.5 °C	Relative Humidity:	54%
Pressure:	1009hPa	Phase :	Line
Test Voltage :	AC 120V/60Hz	Test Mode:	Working

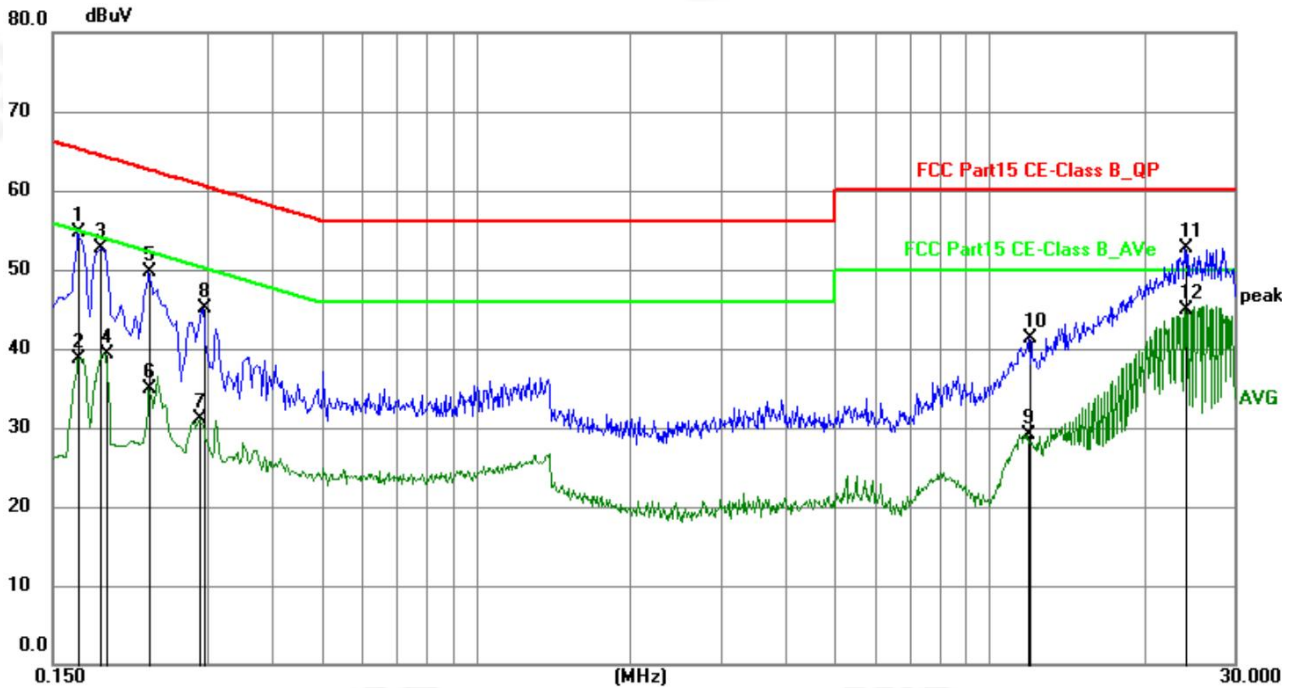

No.	Frequency (MHz)	Reading (dBuV)	Factor (dB)	Level (dBuV)	Limit (dBuV)	Margin (dB)	Detector	P/F	Remark
1	0.1680	42.02	12.61	54.63	65.06	-10.43	QP	P	
2	0.1680	26.07	12.61	38.68	55.06	-16.38	AVG	P	
3	0.1860	40.55	12.23	52.78	64.21	-11.43	QP	P	
4	0.1905	27.22	12.13	39.35	54.01	-14.66	AVG	P	
5	0.2310	37.83	11.78	49.61	62.41	-12.80	QP	P	
6	0.2310	23.10	11.78	34.88	52.41	-17.53	AVG	P	
7	0.2895	19.60	11.51	31.11	50.54	-19.43	AVG	P	
8	0.2940	33.66	11.49	45.15	60.41	-15.26	QP	P	
9	11.9130	20.36	8.73	29.09	50.00	-20.91	AVG	P	
10	11.9445	32.48	8.73	41.21	60.00	-18.79	QP	P	
11	24.0495	42.78	9.90	52.68	60.00	-7.32	QP	P	
12	24.0495	35.10	9.90	45.00	50.00	-5.00	AVG	P	



Conducted Emission At The Mains Terminals Test Data			
Temperature:	24.5 °C	Relative Humidity:	54%
Pressure:	1009hPa	Phase :	Neutral
Test Voltage :	AC 120V/60Hz	Test Mode:	Working

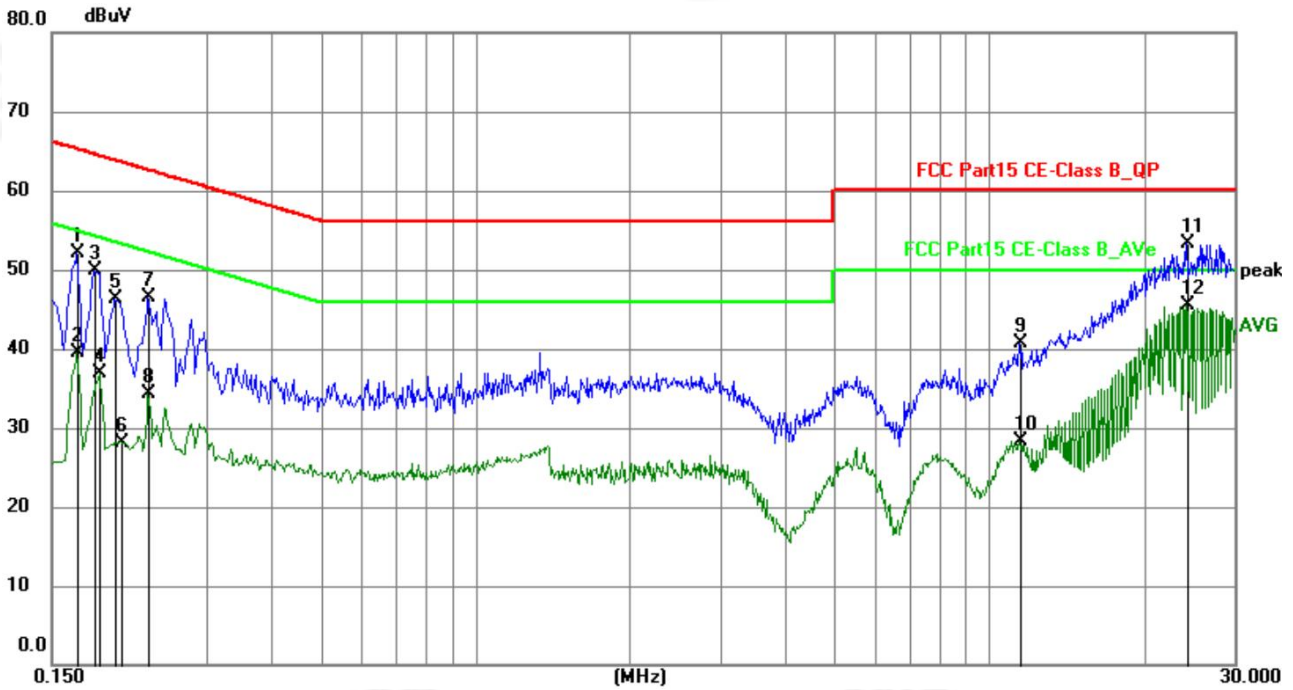

No.	Frequency (MHz)	Reading (dBuV)	Factor (dB)	Level (dBuV)	Limit (dBuV)	Margin (dB)	Detector	P/F	Remark
1	0.1680	39.41	12.61	52.02	65.06	-13.04	QP	P	
2	0.1680	26.92	12.61	39.53	55.06	-15.53	AVG	P	
3	0.1815	37.48	12.33	49.81	64.42	-14.61	QP	P	
4	0.1860	24.73	12.23	36.96	54.21	-17.25	AVG	P	
5	0.1995	34.32	11.93	46.25	63.63	-17.38	QP	P	
6	0.2040	16.30	11.90	28.20	53.45	-25.25	AVG	P	
7	0.2310	34.78	11.78	46.56	62.41	-15.85	QP	P	
8	0.2310	22.53	11.78	34.31	52.41	-18.10	AVG	P	
9	11.4720	31.95	8.67	40.62	60.00	-19.38	QP	P	
10	11.4720	19.68	8.67	28.35	50.00	-21.65	AVG	P	
11	24.2655	43.43	9.90	53.33	60.00	-6.67	QP	P	
12	24.2655	35.57	9.90	45.47	50.00	-4.53	AVG	P	



4.RADIATION EMISSION TEST

4.1 Block Diagram of Test Setup

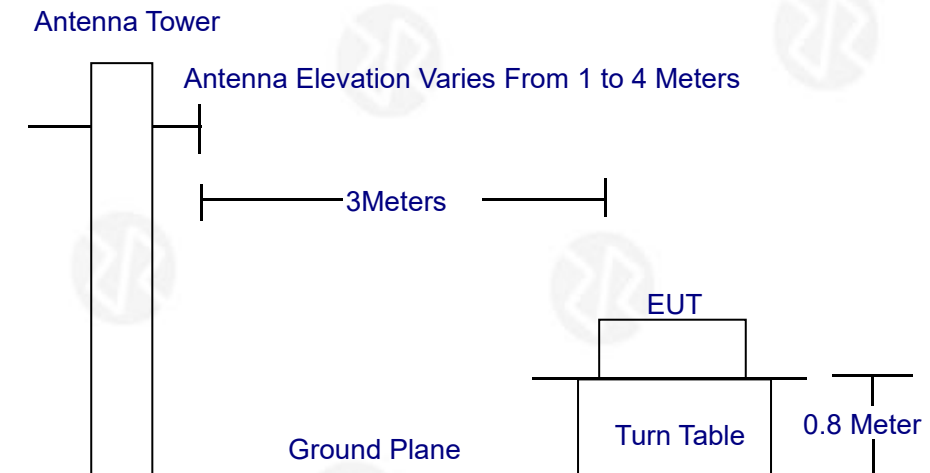

4.2 Test Standard

FCC PART 15 B

4.3 Radiation Limit

FREQUENCY (MHz)	DISTANCE (Meters)	FIELD STRENGTHS LIMITS (dB μ V/m)
30 ~ 88	3	40.0
88 ~ 216	3	43.5
216 ~ 960	3	46.0
960 ~ 1000	3	54.0

4.4 EUT Configuration on Test

The FCC PART 15 B regulations test method must be used to find the maximum emission during radiated emission test. The configuration of EUT is the same as used in conducted emission test. Please refer to Section 2.2.

4.5 Operating Condition of EUT

Same as conducted emission test, which is listed in Section 2.2 except the test set up replaced as Section 4.1.

4.6 Test Procedure

The EUT and its simulators are placed on a turned table that is 0.8 meter above the ground. The turned table can rotate 360 degrees to determine the position of the maximum emission level. The EUT is set 3 meters away from the receiving antenna that is mounted on the antenna tower. The antenna can move up and down between 1 meter and 4 meters to find out the maximum emission level. Broadband antenna (calibrated biconical and log periodical antenna) is used as receiving antenna. Both horizontal and vertical polarization of the antenna is set on test. In order to find the maximum emission levels, the interface cable must be manipulated according to FCC PART 15 B on radiated emission test.

The bandwidth setting on the field strength meter (R&S Test Receiver ESCI) is set at 120KHz below 1GHz, set at 1MHz above 1GHz. The frequency range from 30MHz to 1000MHz is checked. The highest frequency of the internal sources of the EUT was below 108MHz, so the measurement was only made up to 1GHz.

4.7 Test Result

PASS

Please refer to the following page.



Radiation Emission Test Data			
Temperature:	26°C	Relative Humidity:	54%
Pressure:	1009hPa	Phase :	Horizontal
Test Voltage :	AC 120V/60Hz	Test Mode:	Working

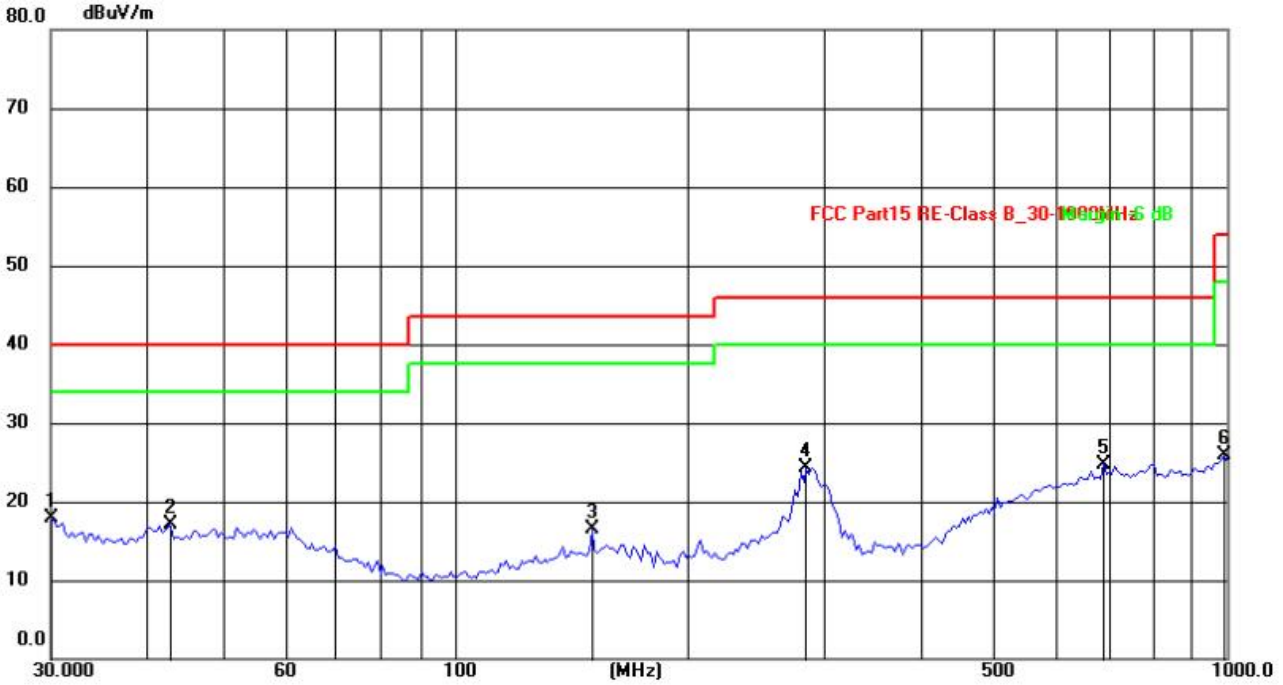

No.	Frequency (MHz)	Reading (dBuV)	Factor (dB/m)	Level (dBuV/m)	Limit (dBuV/m)	Margin (dB)	Detector	Height (cm)	Azimuth (deg.)	P/F	Remark
1	30.2640	32.24	-14.26	17.98	40.00	-22.02	QP				
2	42.6000	31.24	-14.11	17.13	40.00	-22.87	QP				
3	150.5377	33.07	-16.54	16.53	43.50	-26.97	QP				
4	285.4768	39.42	-15.07	24.35	46.00	-21.65	QP				
5	691.9865	31.67	-6.87	24.80	46.00	-21.20	QP				
6	991.2718	30.97	-5.05	25.92	54.00	-28.08	QP				



Radiation Emission Test Data			
Temperature:	26°C	Relative Humidity:	54%
Pressure:	1009hPa	Phase :	Vertical
Test Voltage :	AC 120V/60Hz	Test Mode:	Working

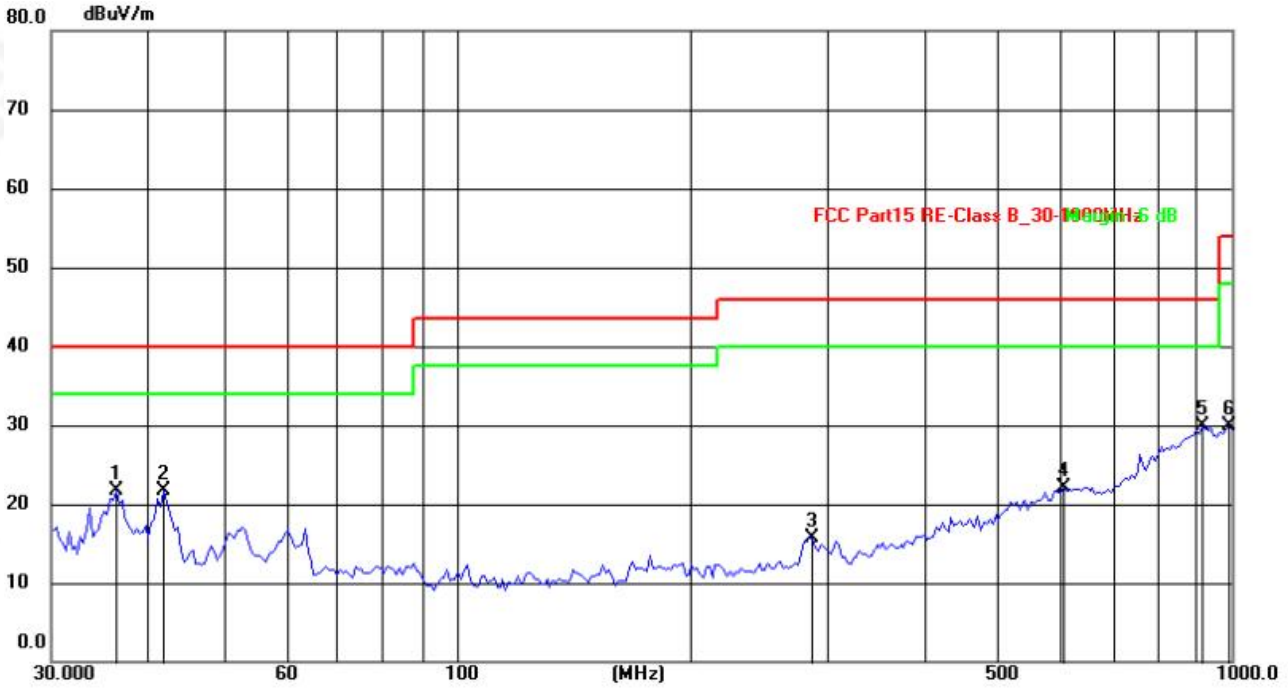

No.	Frequency (MHz)	Reading (dBuV)	Factor (dB/m)	Level (dBuV/m)	Limit (dBuV/m)	Margin (dB)	Detector	Height (cm)	Azimuth (deg.)	P/F	Remark
1	36.3813	39.17	-17.41	21.76	40.00	-18.24	QP				
2	41.8594	38.74	-16.94	21.80	40.00	-18.20	QP				
3	287.9904	34.41	-18.70	15.71	46.00	-30.29	QP				
4	606.7219	29.92	-7.76	22.16	46.00	-23.84	QP				
5	916.0685	30.50	-0.66	29.84	46.00	-16.16	QP				
6	991.2718	30.24	-0.26	29.98	54.00	-24.02	QP				



5.EUT PHOTOGRAPHS

EUT Photo 1



EUT Photo 2





EUT Photo 3



EUT Photo 4

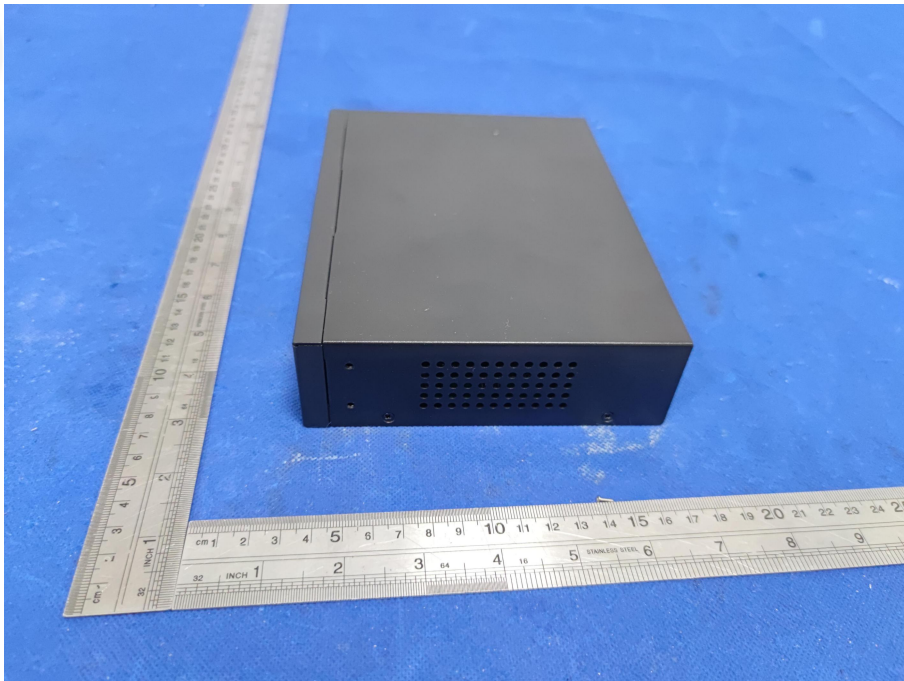



6.EUT TEST PHOTOGRAPHS

RE



CE



***** END OF REPORT *****