



TEST REPORT
ETSI EN 301 489-1 V2.2.3 (2019-11)
ETSI EN 301 489-3 V2.1.1 (2019-03)
ETSI EN 301 489-17 V3.2.2 (2019-12)
EN 55032:2015/EN55035:2017
EN 61000-3-2:2014/EN 61000-3-3:2013

Report Reference No.....: ATT2020SZ061005E2

Compiled by
(position+printed name+signature)..: File administrators Peter peng

Supervised by
(position+printed name+signature)..: Test Engineer Peter peng

Approved by
(position+printed name+signature)..: Manager Jim he

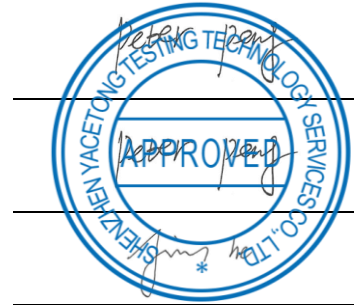

Date of issue.....: Jun.03,2020

Testing Laboratory Name: **Shenzhen Yacetong Testing Technology Services Co., Ltd.**

Address: Room 5009 Baode Industry Center,Baode Industry Center,Lixin
South Road,Huaide Community Fuyong Baoan
District,Shenzhen,China

Applicant's name.....: **SHENZHEN ITOONER TECHNOLOGY CO., LTD**

Address: Building 2&Building 3(The 3rd and 4th Floor) GangZai Road,
Shangxing Community,Xinqiao Street,Baoan District, Shenzhen,
Guangdong, China

Test specification

Standard: **ETSI EN 301 489-1 V2.2.3 (2019-11)**
ETSI EN 301 489-3 V2.1.1 (2019-03)
ETSI EN 301 489-17 V3.2.2 (2019-12)
EN 55032:2015/EN55035:2017
EN 61000-3-2:2014/EN 61000-3-3:2013

Shenzhen Yacetong Testing Technology Services Co., Ltd.. All rights reserved.

This publication may be reproduced in whole or in part for non-commercial purposes as long as the Shenzhen Yacetong Testing Technology Services Co., Ltd. is acknowledged as copyright owner and source of the material. Shenzhen Yacetong Testing Technology Services Co., Ltd. takes no responsibility for and will not assume liability for damages resulting from the reader's interpretation of the reproduced material due to its placement and context.

Test item description: AP

Trade Mark: N/A

Manufacturer: **SHENZHEN ITOONER TECHNOLOGY CO., LTD**

Model/Type reference.....: GNT-AP290

List Model: GNT-AP280,GNT -AP270,GNT-AP260,GNT-AP690,GNT-AP535,GNT-
AP520,GNT-XP502GE,GNT-XP401GE

Ratings: DC 12V From Adapter

Result.....: **PASS**



TEST REPORT

Test Report No. :	ATT2020SZ061005E2	Jun.03,2020
		Date of issue

Equipment under Test : AP

Model /Type : GNT-AP290

Listed Models : GNT-AP280, GNT-AP270,GNT-AP260,GNT-AP690,GNT-AP535,
GNT-AP520,GNT-XP502GE,GNT-XP401GE

Applicant :
SHENZHEN ITOONER TECHNOLOGY CO., LTD

Address :
Building 2&Building 3(The 3rd and 4th Floor) GangZai Road,Shangxing Community,Xinqiao Street,Baoan District, Shenzhen, Guangdong, China

Manufacturer :
SHENZHEN ITOONER TECHNOLOGY CO., LTD

Address :
Building 2&Building 3(The 3rd and 4th Floor) GangZai Road,Shangxing Community,Xinqiao Street,Baoan District, Shenzhen, Guangdong, China

Test Result	PASS
--------------------	-------------

The test report merely corresponds to the test sample.
It is not permitted to copy extracts of these test result without the written permission of the test laboratory.



Contents

1.	<u>TEST STANDARDS</u>	<u>4</u>
2.	<u>SUMMARY</u>	<u>5</u>
2.1.	General Remarks	5
2.2.	Product Description	5
2.3.	EUT operation mode	6
2.4.	Modifications	6
3.	<u>TEST ENVIRONMENT</u>	<u>7</u>
3.1.	Address of the test laboratory	7
3.2.	Environmental conditions	7
3.3.	Test Description	7
3.4.	Statement of the measurement uncertainty	8
3.5.	Equipments Used during the Test	8
4.	<u>TEST CONDITIONS AND RESULTS.....</u>	<u>11</u>
4.1.	EMISSION	11
4.1.1.	Radiated Emission.....	11
4.1.2.	Conducted Emission.....	15
4.1.3.	Harmonic Current Emission.....	19
4.1.4.	Voltage Fluctuation and Flicker	20
4.2.	IMMUNITY	22
4.2.1.	Performance criteria	22
4.2.2.	Electrostatic Discharge	25
4.2.3.	RF Electromagnetic Field	27
4.2.4.	Surges	28
4.2.5.	RF- Common Mode 0.15MHz to 80MHz	29
4.2.6.	Fast Transients Common Mode	30
4.2.7.	Voltage Dips and Interruptions	31
5.	<u>TEST SET-UP PHOTOS OF THE EUT</u>	<u>32</u>
6.	<u>EXTERNAL AND INTERNAL PHOTOS OF THE EUT</u>	<u>34</u>



1. TEST STANDARDS

The tests were performed according to following standards:

[ETSI EN 301 489-1 V2.2.3 \(2019-11\)](#)—ElectroMagnetic Compatibility (EMC) standard for radio equipment and services; Part 1: Common technical requirements; Harmonised Standard for ElectroMagnetic Compatibility
[ETSI EN 301 489-3 V2.1.1 \(2019-03\)](#)—ElectroMagnetic Compatibility (EMC) standard for radio equipment and services; Part 3: Specific conditions for Short-Range Devices (SRD) operating on frequencies between 9 kHz and 246 GHz; Harmonised Standard covering the essential requirements of article 3.1(b) of Directive 2014/53/EU

[Draft ETSI EN 301 489-17 V3.2.0 \(2017-03\)](#)—ElectroMagnetic Compatibility (EMC) standard for radio equipment and services; Part 17: Specific conditions for Broadband Data Transmission Systems; Harmonised Standard covering the essential requirements of article 3.1(b) of Directive 2014/53/EU

[EN55032:2015](#) Electromagnetic compatibility of multimedia equipment - Emission Requirements

[EN 55035:2017](#) Electromagnetic compatibility of multimedia equipment - Immunity requirements

[EN 61000-3-2: 2014](#) Electromagnetic compatibility (EMC) -- Part 3-2: Limits - Limits for harmonic current emissions (equipment input current up to and including 16 A per phase)

[EN 61000-3-3: 2013](#) Electromagnetic compatibility (EMC) -- Part 3-3: Limits - Limitation of voltage changes, voltage fluctuations and flicker in public low-voltage supply systems, for equipment with rated current ≤ 16 A per phase and not subject to conditional connection



2. SUMMARY

2.1. General Remarks

Date of receipt of test sample	:	May.25, 2020
Testing commenced on	:	May.25, 2020
Testing concluded on	:	Jun.03, 2020

2.2. Product Description

Product Name:	AP
Trade Mark:	N/A
Model/Type reference:	GNT-AP290
List Model:	GNT-AP280,GNT-AP270,GNT-AP260,GNT-AP690,GNT-AP535,GNT-AP520, GNT-XP502GE,GNT-XP401GE
Power supply:	DC 12V From Adapter
Auxiliary testing adapter information (Supplied by Test Lab) :	Model: XH1200-1500LG Input: AC 100-240V~50/60Hz 0.5A Output:DC 12V 1.5A
2.4GWIFI	
WLAN	Supported 802.11b/802.11g/802.11n HT20
WLAN CE Operation frequency	IEEE 802.11b:2412-2472MHz IEEE 802.11g:2412-2472MHz IEEE 802.11n HT20:2412-2472MHz
WLAN CE Modulation Type	IEEE 802.11b: DSSS(CCK,DQPSK,DBPSK) IEEE 802.11g: OFDM(64QAM, 16QAM, QPSK, BPSK) IEEE 802.11n HT20: OFDM (64QAM, 16QAM, QPSK,BPSK)
Channel number:	13
Channel separation:	5MHz
5G WIFI	
Operation frequency	802.11a/n/ac (20MHz): 5180~5825MHz 802.11n/ac(40MHz):5190~5795MHz 802.11ac(HT80):5210~5775MHz
Modulation Type	802.11a(OFDM): BPSK,QPSK,16-QAM,64-QAM 802.11n(OFDM): BPSK,QPSK,16-QAM,64-QAM 802.11ac(OFDM): BPSK,QPSK,16-QAM,64-QAM,256-QAM
Operation frequency	5745MHz-5825MHz
Modulation Type	OFDM(64QAM, 16QAM, QPSK, BPSK)
Remark: The products are identical in interior structure, electrical circuits and components, just model names are different.	



2.3. EUT operation mode

Test mode	WIFI	Data transmission	Adapter
1	■	■	■

Note:

1. ■ is operation mode.
2. Pre-scan above all test mode, found below test mode which it was worse case mode.

Test item	Test mode (Worse case mode)
Conducted emission (AC Mains)	Mode 1
Conducted emission (network port)	Mode 1
Radiated emission	Mode 1
EMS	Mode 1

2.4. Modifications

No modifications were implemented to meet testing criteria.



3. TEST ENVIRONMENT

3.1. Address of the test laboratory

Shenzhen Yacetong Testing Technology Services Co., Ltd.
Room 5009 Baode Industry Center, Baode Industry Center, Lixin South Road, Huaide Community Fuyong
Baoan District, Shenzhen, China

3.2. Environmental conditions

During the measurement the environmental conditions were within the listed ranges:

Normal Temperature:	25°C
Lative Humidity	55 %
Air Pressure	989 hPa

3.3. Test Description

Emission Measurement		
Radiated Emission	ETSI EN 301 489-1 V2.2.3 (2019-11) ETSI EN 301 489-3 V2.1.1 (2019-03) ETSI EN 301 489-17 V3.2.2 (2019-12) EN 55032:2015	PASS
Conducted Emission	ETSI EN 301 489-1 V2.2.3 (2019-11) ETSI EN 301 489-3 V2.1.1 (2019-03) ETSI EN 301 489-17 V3.2.2 (2019-12) EN 55032:2015	PASS
Harmonic Current Emissions	ETSI EN 301 489-1 V2.2.3 (2019-11) ETSI EN 301 489-3 V2.1.1 (2019-03) ETSI EN 301 489-17 V3.2.2 (2019-12) EN 61000-3-2:2014	N/A
Voltage Fluctuations and Flicker	ETSI EN 301 489-1 V2.2.3 (2019-11) ETSI EN 301 489-3 V2.1.1 (2019-03) ETSI EN 301 489-17 V3.2.2 (2019-12) EN 61000-3-3:2013	N/A
Immunity Measurement		
Electrostatic Discharge	ETSI EN 301 489-1 V2.2.3 (2019-11) ETSI EN 301 489-3 V2.1.1 (2019-03) ETSI EN 301 489-17 V3.2.2 (2019-12) EN55035:2017	PASS
RF Electromagnetic Field	ETSI EN 301 489-1 V2.2.3 (2019-11) ETSI EN 301 489-3 V2.1.1 (2019-03) ETSI EN 301 489-17 V3.2.2 (2019-12) EN55035:2017	PASS
Fast Transients Common Mode	ETSI EN 301 489-1 V2.2.3 (2019-11) ETSI EN 301 489-3 V2.1.1 (2019-03) ETSI EN 301 489-17 V3.2.2 (2019-12) EN55035:2017	PASS
RF Common Mode 0,15 MHz to 80 MHz	ETSI EN 301 489-1 V2.2.3 (2019-11) ETSI EN 301 489-3 V2.1.1 (2019-03) ETSI EN 301 489-17 V3.2.2 (2019-12) EN55035:2017	PASS
Voltage Dips and Interruptions	ETSI EN 301 489-1 V2.2.3 (2019-11) ETSI EN 301 489-3 V2.1.1 (2019-03) ETSI EN 301 489-17 V3.2.2 (2019-12) EN55035:2017	PASS
Surges	ETSI EN 301 489-1 V2.2.3 (2019-11) ETSI EN 301 489-3 V2.1.1 (2019-03) ETSI EN 301 489-17 V3.2.2 (2019-12)	PASS



	EN55035:2017
--	--------------

Remark:1. N/A means “not applicable”.
2.The measurement uncertainty is not included in the test result.

3.4. Statement of the measurement uncertainty

The data and results referenced in this document are true and accurate. The reader is cautioned that there may be errors within the calibration limits of the equipment and facilities. The measurement uncertainty was calculated for all measurements listed in this test report acc. to CISPR 16 - 4 „Specification for radio disturbance and immunity measuring apparatus and methods – Part 4: Uncertainty in EMC Measurements“and is documented in the Shenzhen Shenzhen Global Test Service Co.,Ltd acc. to DIN EN ISO/IEC 17025. Furthermore, component and process variability of devices similar to that tested may result in additional deviation. The manufacturer has the sole responsibility of continued compliance of the device. Hereafter the best measurement capability for Shenzhen Shenzhen Global Test Service Co.,Ltd for Products Quality is reported:

Test	Range	Measurement Uncertainty	Notes
Radiated Emission	30~1000MHz	4.24 dB	(1)
Radiated Emission	1~18GHz	5.16 dB	(1)
Conducted Disturbance	0.15~30MHz	3.39 dB	(1)

(1) This uncertainty represents an expanded uncertainty expressed at approximately the 95% confidence level using a coverage factor of k=2.

3.5. Equipments Used during the Test

CONDUCTED EMISSION

Item	Kind of Equipment	Manufacturer	Type No.	Last calibration	Calibrated until	Calibration period
1	LISN	R&S	ENV216	2019/09/19	2020/09/18	1 year
2	LISN	R&S	ENV216	2019/09/19	2020/09/18	1 year
3	EMI Test Receiver	R&S	ESCI-7	2019/09/19	2020/09/18	1 year
4	Wideband Radio Communication tester	R&S	CMW500	2019/09/19	2020/09/18	1 year

RADIATED TEST SITE

Item	Kind of Equipment	Manufacturer	Type No.	Last calibration	Calibrated until	Calibration period
1	Spectrum analyzer	R&S	FSU26	2019/09/19	2020/09/18	2 year
2	Trilog Broadband Antenna	Schwarzbeck	VULB9163	2019/09/19	2020/09/18	1 year
3	Double Ridged Horn Antenna	R&S	HF907	2019/09/19	2020/09/18	1 year
4	Pre-Amplifier	R&S	SCU-01	2019/09/19	2020/09/18	2 year
5	Pre-amplifier	A.H.	PAM0-0118	2019/09/19	2020/09/18	1 year
6	RF Cable	R&S	R01	2019/09/19	2020/09/18	1 year
7	RF Cable	R&S	R02	2019/09/19	2020/09/18	1 year



8	RF Cable	R&S	R01	2019/09/19	2020/09/18	1 year
9	RF Cable	R&S	R02	2019/09/19	2020/09/18	1 year

HARMONICS AND FILCK

Item	Kind of Equipment	Manufacturer	Type No.	Last calibration	Calibrated until	Calibration period
1	Harmonic flicker tester	California Instruments	5001ix	2019/09/19	2020/09/18	1 year
2	Wideband Radio Communication tester	R&S	CMW500	2019/09/19	2020/09/18	1 year

ESD

Item	Kind of Equipment	Manufacturer	Type No.	Last calibration	Calibrated until	Calibration period
1	ESD device	Schloder	SESD 216	2019/09/19	2020/09/18	1 year
2	Wideband Radio Communication tester	R&S	CMW500	2019/09/19	2020/09/18	1 year

RS

Item	Kind of Equipment	Manufacturer	Type No.	Last calibration	Calibrated until	Calibration period
1	Signal generator	Agilent	83630A	2019/09/19	2020/09/18	1 year
2	Hf antenna	Schwarzbeck	LB-180400-KF	2019/09/19	2020/09/18	2 year
3	Power amplifier	R&S	NTWPA-1060040E	2019/09/19	2020/09/18	1 year
4	Broadband antenna	Schwarzbeck	VULB 9163	2019/09/19	2020/09/18	2 year
5	Power amplifier	R&S	5225F	2019/09/19	2020/09/18	1 year
6	Wideband Radio Communication tester	R&S	CMW500	2019/09/19	2020/09/18	1 year

SURGE, EFT/BURST, VOLTAGE INTERRUPTION/DIPS

Item	Kind of Equipment	Manufacturer	Type No.	Last calibration	Calibrated until	Calibration period
1	Full-featured immunity tester	HTEC	HV1P16T	2019/09/19	2020/09/18	1 year
2	Group pulse coupling clamp	HTEC	H3C	2019/09/19	2020/09/18	1 year
3	Wideband Radio Communication tester	R&S	CMW500	2019/09/19	2020/09/18	1 year

INJECTION CURRENT



Item	Kind of Equipment	Manufacturer	Type No.	Last calibration	Calibrated until	Calibration period
1	Integrated Conduction Sensitivity Test System	Schloder	CDG6000	2019/09/19	2020/09/18	1 year
2	Wideband Radio Communication tester	R&S	CMW500	2019/09/19	2020/09/18	1 year

The calibration interval is 1 year



4. TEST CONDITIONS AND RESULTS

4.1. EMISSION

4.1.1. Radiated Emission

LIMIT

Please refer to ETSI EN301489-1 Clause 8.2.3, Table 4 and EN55032 Annex A, Table A.2,A.3, and Class B

TEST CONFIGURATION

- a) Radiated emission test set-up, frequency below 1000MHz:

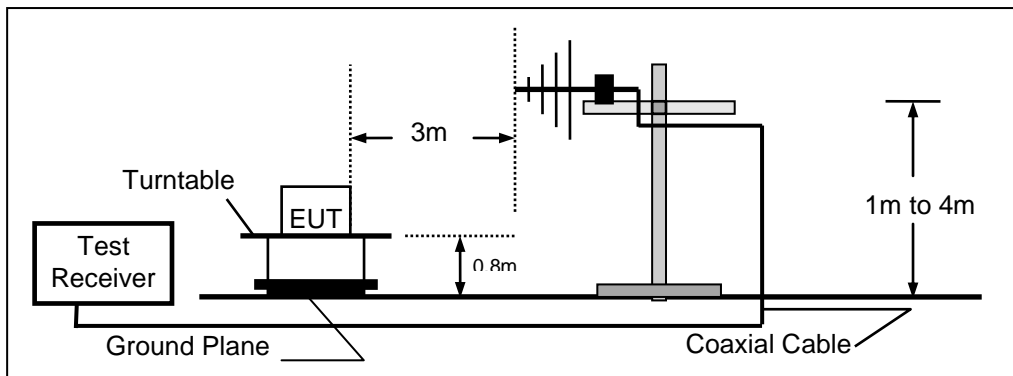

- b) Radiated emission test set-up, frequency above 1000MHz

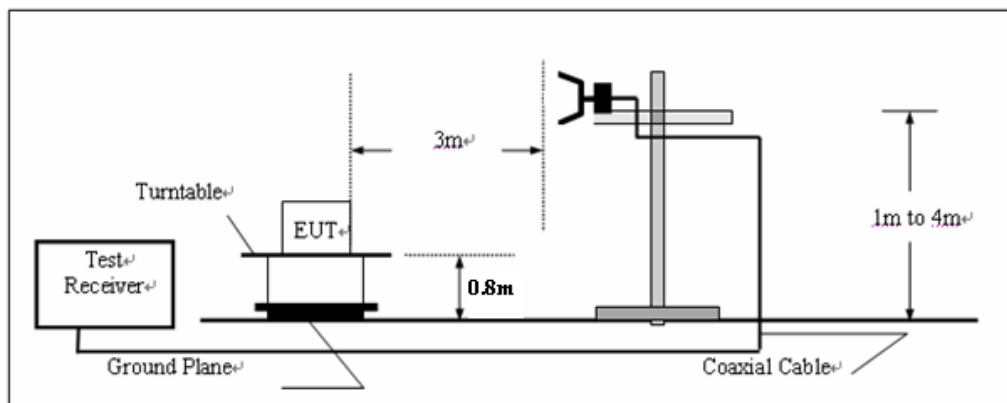

TEST PROCEDURE

Please refer to ETSI EN 301 489-1 Clause 8.2.3 and EN55032 Annex A for the measurement methods

TEST RESULTS

Passed

Please refer to the below test data:

For Host

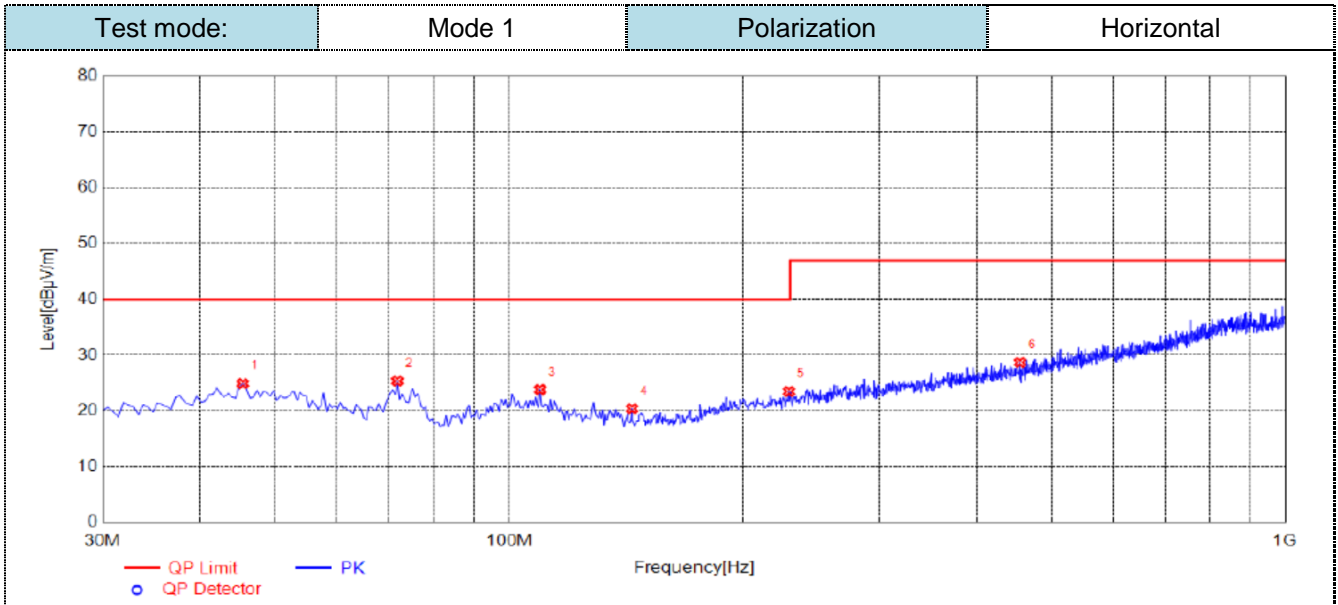

Suspected List

NO.	Frequency [MHz]	Reading [dBμV/m]	Factor [dB]	Result [dBμV/m]	Limit [dBμV/m]	Margin [dB]	Height [cm]	Angle [°]	Detector	Polarity	Remark
1	45.5200	39.63	-14.77	24.86	40.00	15.14	100	170	PK	Horizontal	PASS
2	71.7100	44.62	-19.28	25.34	40.00	14.66	100	200	PK	Horizontal	PASS
3	109.5400	40.78	-17.00	23.78	40.00	16.22	100	260	PK	Horizontal	PASS
4	143.9750	40.40	-20.06	20.34	40.00	19.66	100	210	PK	Horizontal	PASS
5	229.3350	39.10	-15.66	23.44	40.00	16.56	100	40	PK	Horizontal	PASS
6	455.3450	39.35	-10.65	28.70	47.00	18.30	100	260	PK	Horizontal	PASS

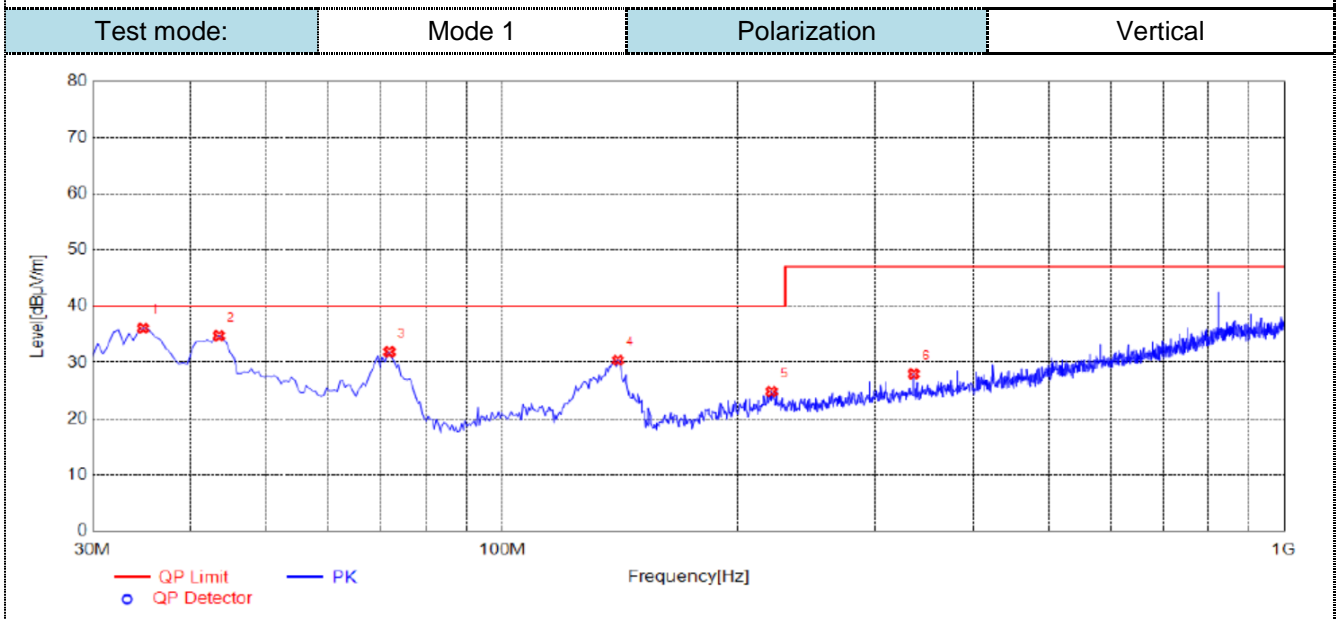



Suspected List

NO.	Frequency [MHz]	Reading [dB μ V/m]	Factor [dB]	Result [dB μ V/m]	Limit [dB μ V/m]	Margin [dB]	Height [cm]	Angle [°]	Detector	Polarity	Remark
1	34.8500	53.18	-17.10	36.08	40.00	3.92	100	130	PK	Vertical	PASS
2	43.5800	49.83	-15.10	34.73	40.00	5.27	100	310	PK	Vertical	PASS
3	71.7100	51.17	-19.28	31.89	40.00	8.11	100	20	PK	Vertical	PASS
4	140.5800	50.73	-20.34	30.39	40.00	9.61	100	340	PK	Vertical	PASS
5	221.0900	40.74	-15.93	24.81	40.00	15.19	100	80	PK	Vertical	PASS
6	336.0350	41.26	-13.30	27.96	47.00	19.04	100	120	PK	Vertical	PASS

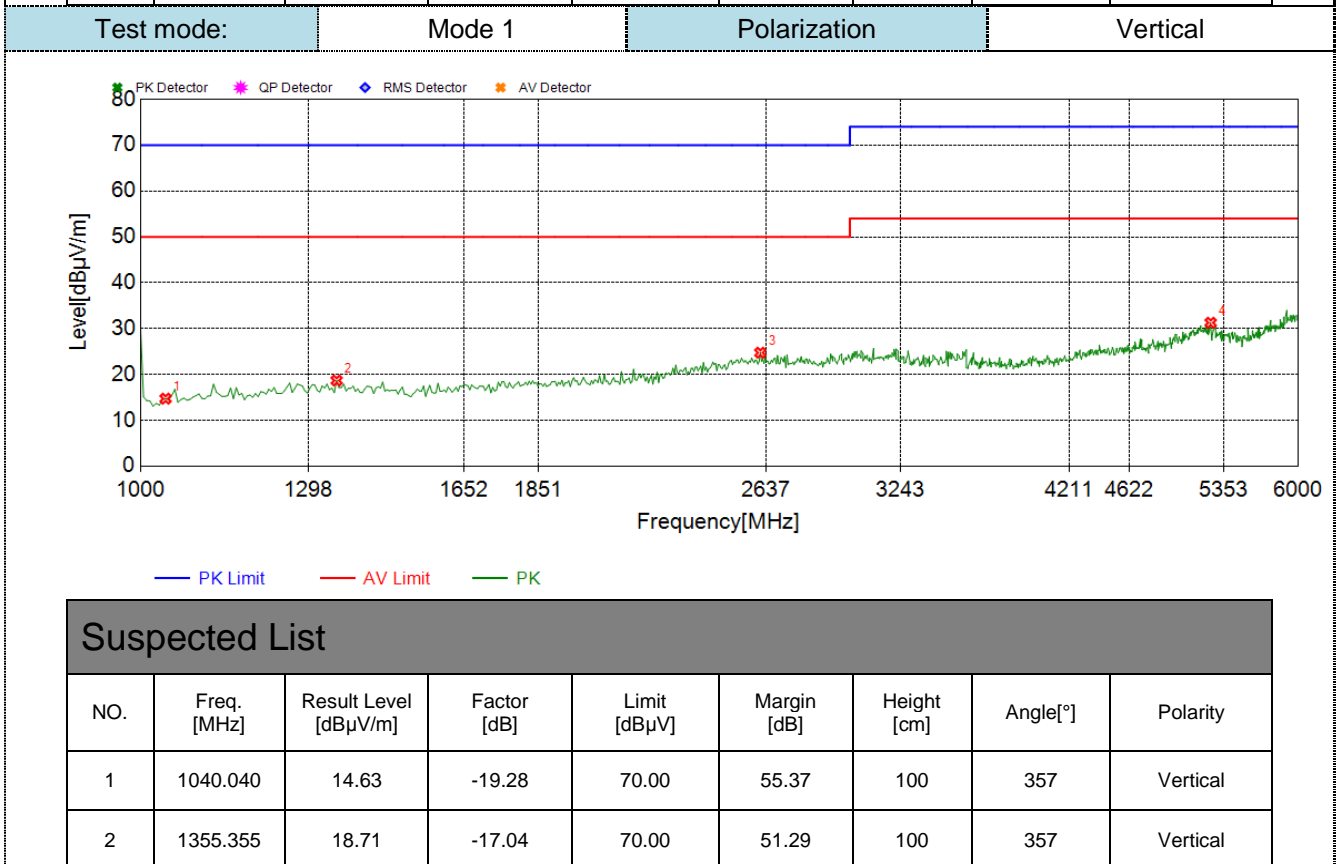
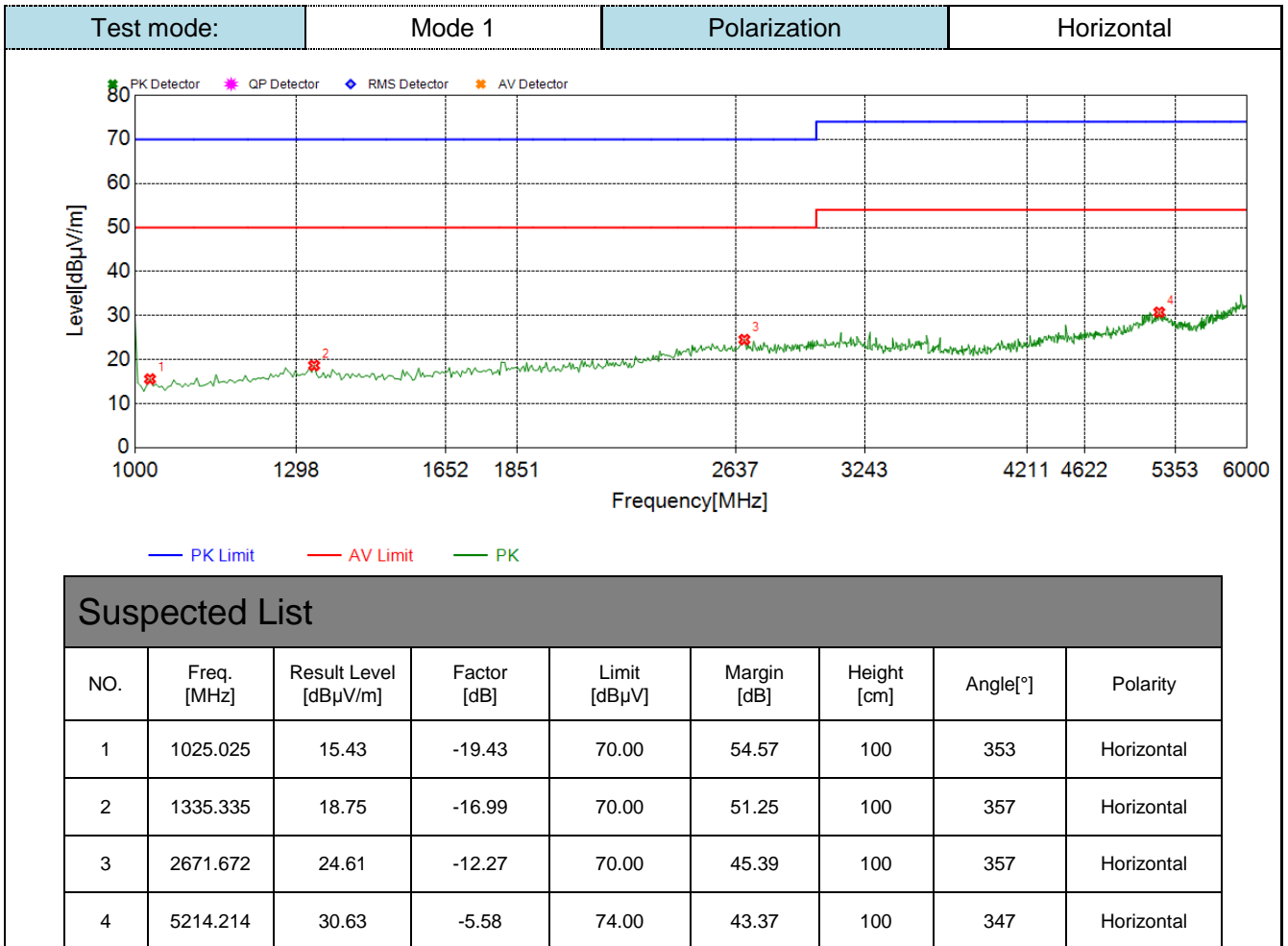



3	2611.612	24.68	-12.21	70.00	45.32	100	357	Vertical
4	5244.244	31.32	-5.63	74.00	42.68	100	348	Vertical

4.1.2. Conducted Emission

LIMIT

Please refer to ETSI EN301489-1 Clause 8.4.3, Table 8 and EN55032 Annex A, Table A.10, A.12

TEST CONFIGURATION

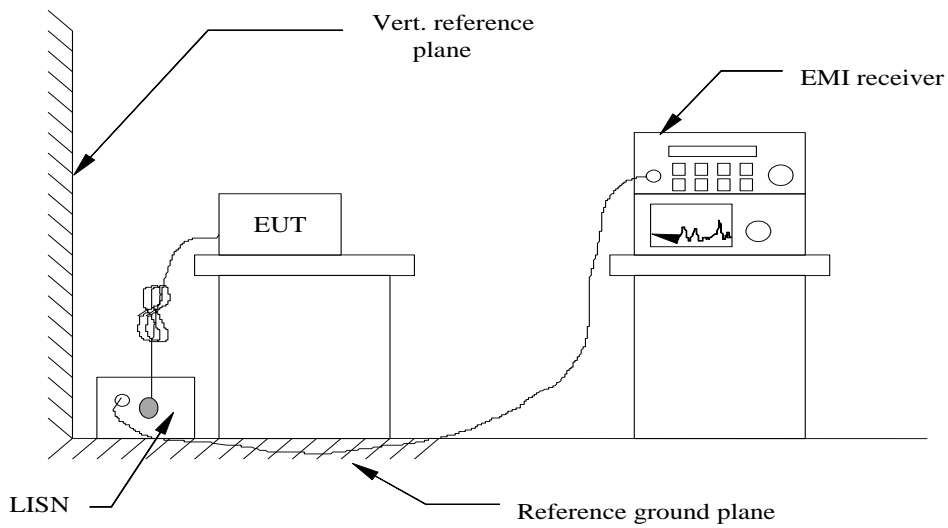

TEST PROCEDURE

Please refer to ETSI EN 301 489-1 Clause 8.4.3 and EN55032 Annex A for the measurement methods.

TEST RESULTS

Passed

Please refer to the below test data:



For AC mains

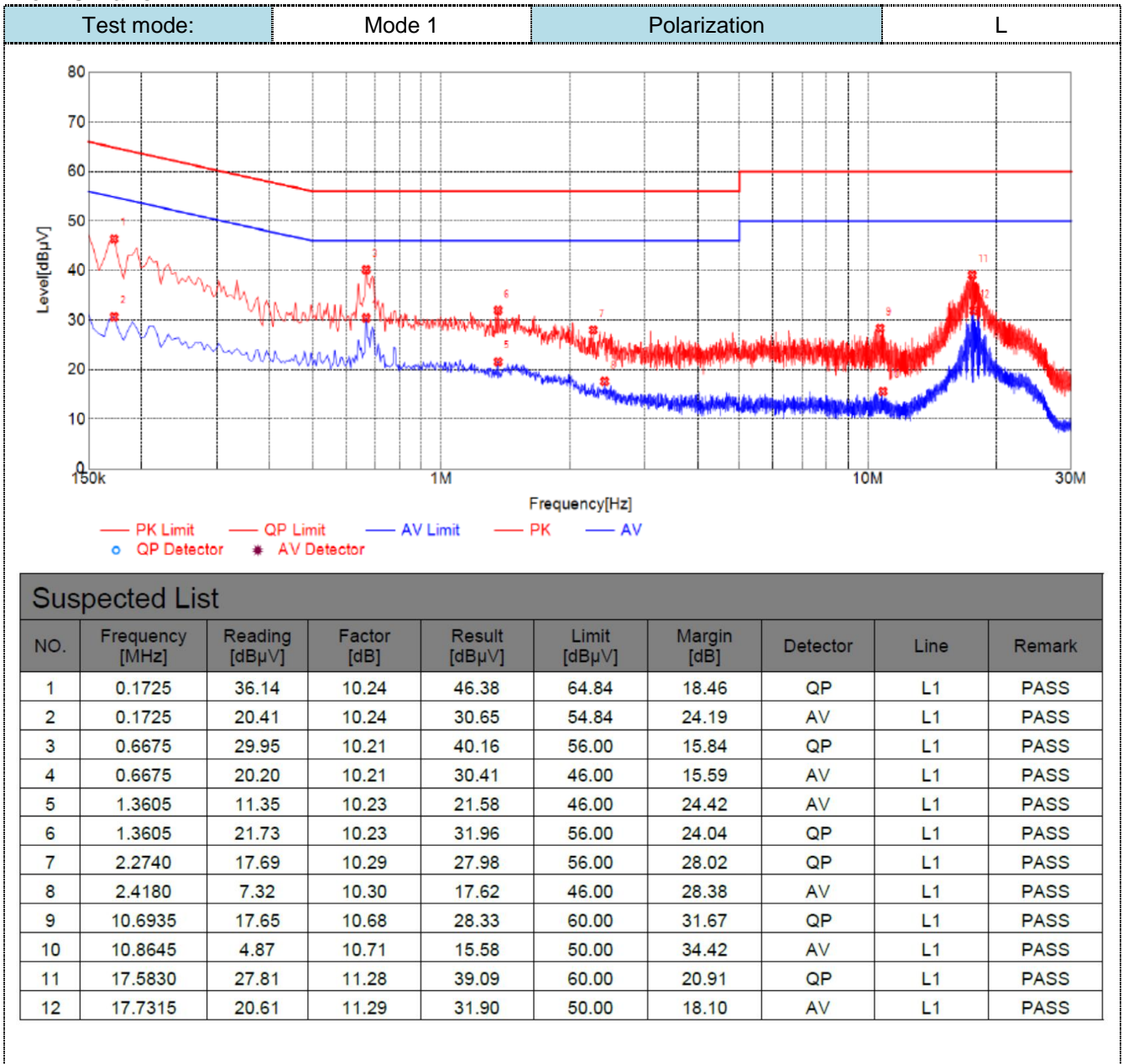

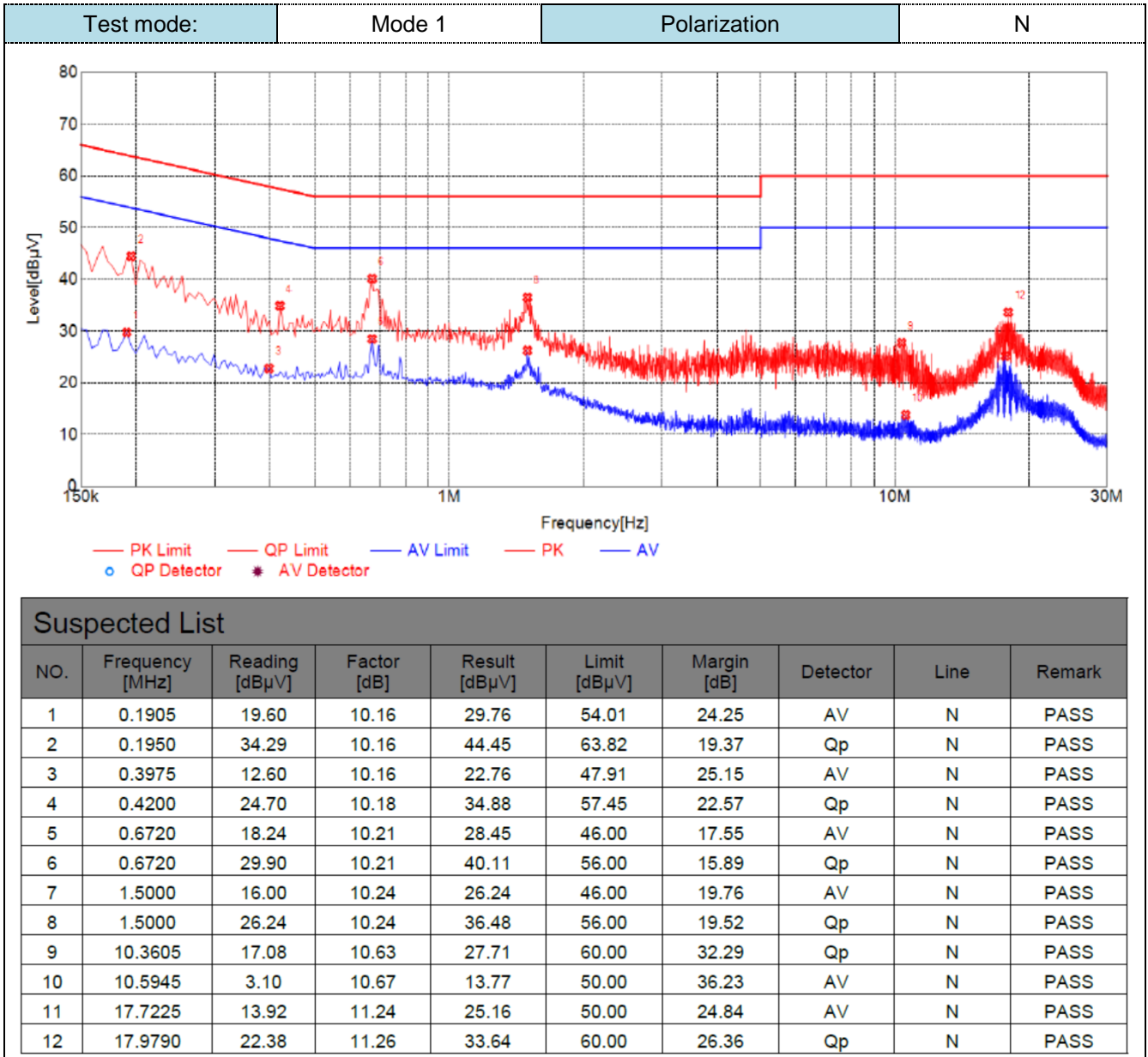



For network port

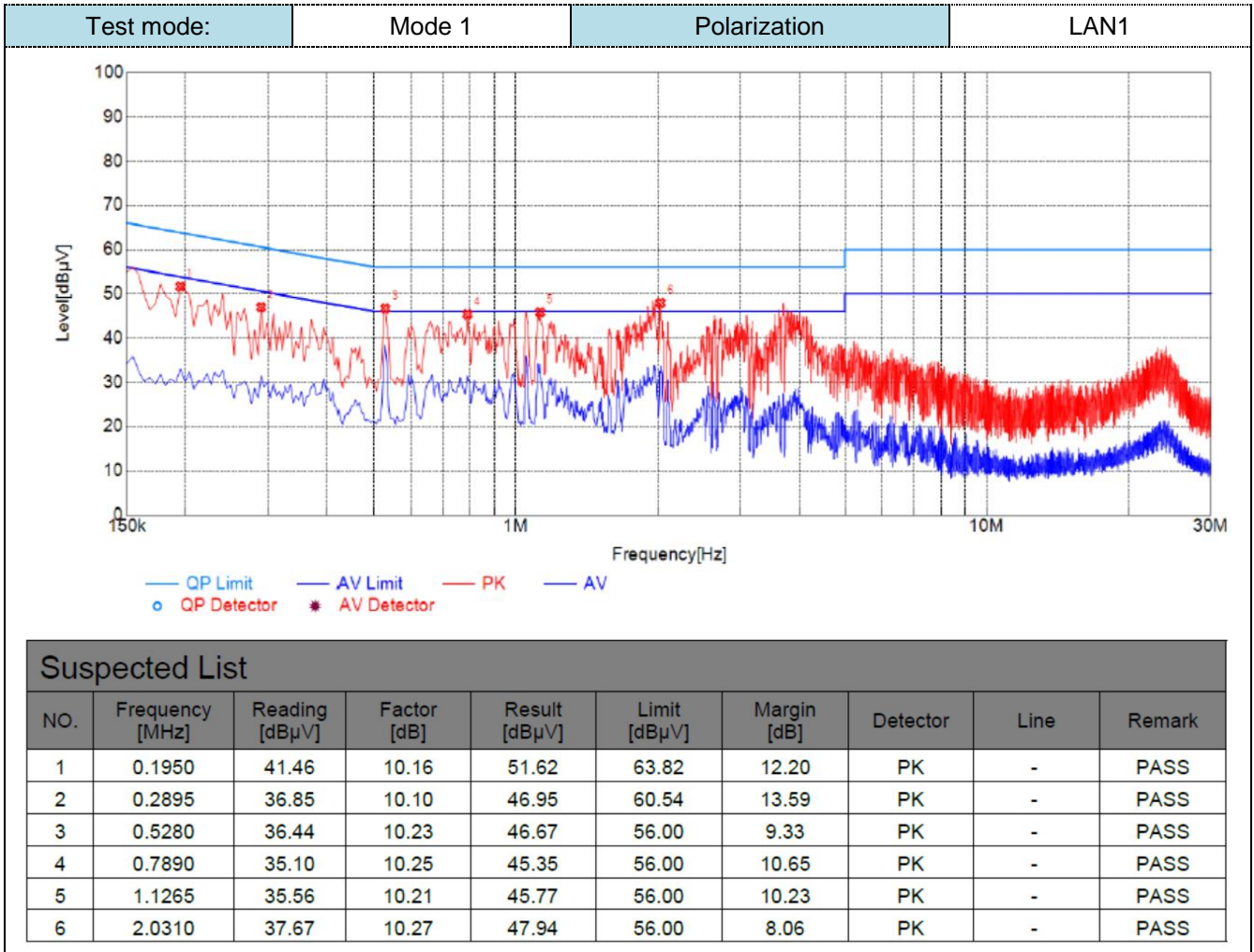



4.1.3. Harmonic Current Emission

LIMIT

Please refer to EN 61000-3-2

TEST CONFIGURATION

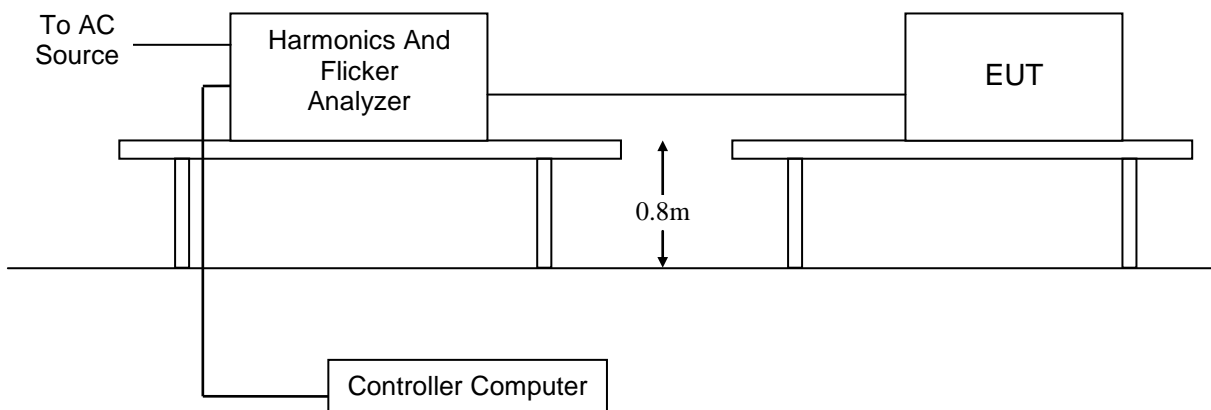

TEST PROCEDURE

Please refer to EN 61000-3-2 for the measurement methods.

TEST RESULTS

The power of the Adppter is less than 75W, So this test item is not applicable for the EUT.



4.1.4. Voltage Fluctuation and Flicker

LIMIT

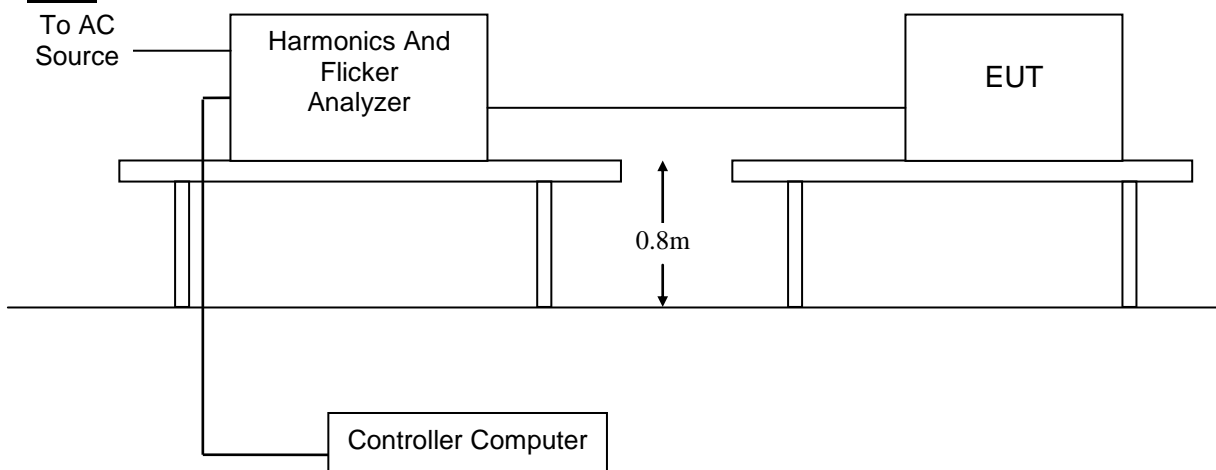

Please refer to EN 61000-3-3

TEST CONFIGURATION

TEST PROCEDURE

Please refer to EN 61000-3-3 for the measurement methods.

TEST RESULTS

The maximum input power of the EUT is less than 20W, which unlikely to produce significant voltage fluctuation. Therefore this test item is not applicable for the EUT.

*See clause 6.1*** *** EN 61000-3-3:2013, clause 6.1:" ... Tests need not be made on equipment which is unlikely to produce significant voltage fluctuations or flicker. ...".*





4.2. IMMUNITY

4.2.1. Performance criteria

■ ETSI EN301489-17

General performance criteria

- Performance criteria A for immunity tests with phenomena of a continuous nature;
- Performance criteria B for immunity tests with phenomena of a transient nature;
- Performance criteria C for immunity tests with power interruptions exceeding a certain time.

The equipment shall meet the minimum performance criteria as specified in the following.

Criteria	During test	After test
A	Shall operate as intended. May show degradation of performance (see note 1). Shall be no loss of function. Shall be no unintentional transmissions.	Shall operate as intended. Shall be no degradation of performance (see note 2). Shall be no loss of function. Shall be no loss of stored data or user programmable functions.
B	May show loss of function (one or more). May show degradation of performance (see note 1). No unintentional transmissions.	Functions shall be self-recoverable. Shall operate as intended after recovering. Shall be no degradation of performance (see note 2). Shall be no loss of stored data or user programmable functions.
C	May be loss of function (one or more).	Functions shall be recoverable by the operator. Shall operate as intended after recovering. Shall be no degradation of performance (see note 2).

NOTE 1:

Degradation of performance during the test is understood as a degradation to a level not below a minimum performance level specified by the manufacturer for the use of the apparatus as intended. In some cases the specified minimum performance level may be replaced by a permissible degradation of performance.

If the minimum performance level or the permissible performance degradation is not specified by the manufacturer then either of these may be derived from the product description and documentation (including leaflets and advertising) and what the user may reasonably expect from the apparatus if used as intended.

NOTE 2:

No degradation of performance after the test is understood as no degradation below a minimum performance level specified by the manufacturer for the use of the apparatus as intended. In some cases the specified minimum performance level may be replaced by a permissible degradation of performance. After the test no change of actual operating data or user retrievable data is allowed.

If the minimum performance level or the permissible performance degradation is not specified by the manufacturer then either of these may be derived from the product description and documentation (including leaflets and advertising) and what the user may reasonably expect from the apparatus if used as intended.

Performance criteria for Continuous phenomena applied to Transmitters (CT)



The performance criteria A shall apply.

Tests shall be repeated with the EUT in standby mode (if applicable) to ensure that unintentional transmission does not occur. In systems using acknowledgement signals, it is recognized that an ACKnowledgement (ACK) or Not ACKnowledgement (NACK) transmission may occur, and steps should be taken to ensure that any transmission resulting from the application of the test is correctly interpreted.

Performance criteria for Transient phenomena applied to Transmitters (TT)

The performance criteria B shall apply, except for voltage dips of 100 ms and voltage interruptions of 5 000 ms duration, for which performance criteria C shall apply.

Tests shall be repeated with the EUT in standby mode (if applicable) to ensure that unintentional transmission does not occur. In systems using acknowledgement signals, it is recognized that an acknowledgement (ACK) or not-acknowledgement (NACK) transmission may occur, and steps should be taken to ensure that any transmission resulting from the application of the test is correctly interpreted.

Performance criteria for Continuous phenomena applied to Receivers (CR)

The performance criteria A shall apply.

Where the EUT is a transceiver, under no circumstances, shall the transmitter operate unintentionally during the test. In systems using acknowledgement signals, it is recognized that an ACK or NACK transmission may occur, and steps should be taken to ensure that any transmission resulting from the application of the test is correctly interpreted.

Performance criteria for Transient phenomena applied to Receivers (TR)

The performance criteria B shall apply, except for voltage dips of 100 ms and voltage interruptions of 5 000 ms duration for which performance criteria C shall apply.

Where the EUT is a transceiver, under no circumstances, shall the transmitter operate unintentionally during the test. In systems using acknowledgement signals, it is recognized that an ACK or NACK transmission may occur, and steps should be taken to ensure that any transmission resulting from the application of the test is correctly interpreted.

■ ETSI EN301489-3

In the table below:

performance criterion A applies for immunity tests with phenomena of a continuous nature;

performance criterion B applies for immunity tests with phenomena of a transient nature.

NOTE: Whether a phenomenon is considered transient, continuous or otherwise is indicated in the test procedures for the phenomenon in ETSI EN 301 489-1 [1], clause 9.

Table 2: Performance Requirements

Criterion	During test	After test
A	Operate as intended No loss of function No unintentional responses	Operate as intended No loss of function No degradation of performance No loss of stored data or user programmable functions
B	May show loss of function No unintentional responses	Operate as intended Lost function(s) shall be self-recoverable No degradation of performance No loss of stored data or user programmable functions

Where "operate as intended" or "no loss of function" is specified, the EUT shall demonstrate correct functioning as described in clause 5.

Where the EUT has more than one mode of operation (see clause 4.5.2), an unplanned transition from one mode to another is considered as an unintentional response. The EUT shall be tested in sufficient modes to confirm there are no such unintentional responses.



■ **Performance Criterion of EN55035**

Criterion A: The equipment shall continue to operate as intended without operator intervention. No degradation of performance or loss of function is allowed below a performance level specified by the manufacturer when the equipment is used as intended.

Criterion B: After the test, the equipment shall continue to operate as intended without operator intervention. No degradation of performance or loss of function is allowed, after the application of the phenomena below a performance level specified by the manufacturer, when the equipment is used as intended.

Criterion C: Loss of function is allowed, provided the function is self-recoverable, or can be restored by the operation of the controls by the user in accordance with the manufacturer's instructions.

■ **Performance Criterion of EN55035**

Criterion A: The equipment shall continue to operate as intended without operator intervention. No degradation of performance or loss of function is allowed below a performance level specified by the manufacturer when the equipment is used as intended.

Criterion B: After the test, the equipment shall continue to operate as intended without operator intervention. No degradation of performance or loss of function is allowed, after the application of the phenomena below a performance level specified by the manufacturer, when the equipment is used as intended.

Criterion C: Loss of function is allowed, provided the function is self-recoverable, or can be restored by the operation of the controls by the user in accordance with the manufacturer's instructions.



4.2.2. Electrostatic Discharge

LIMIT

SEVERITY LEVELS OF ELECTROSTATIC DISCHARGE

Test level: Contact Discharge at $\pm 2\text{KV}$, $\pm 4\text{KV}$ Air Discharge at $\pm 2\text{KV}$, $\pm 4\text{KV}$, $\pm 8\text{KV}$

TEST CONFIGURATION

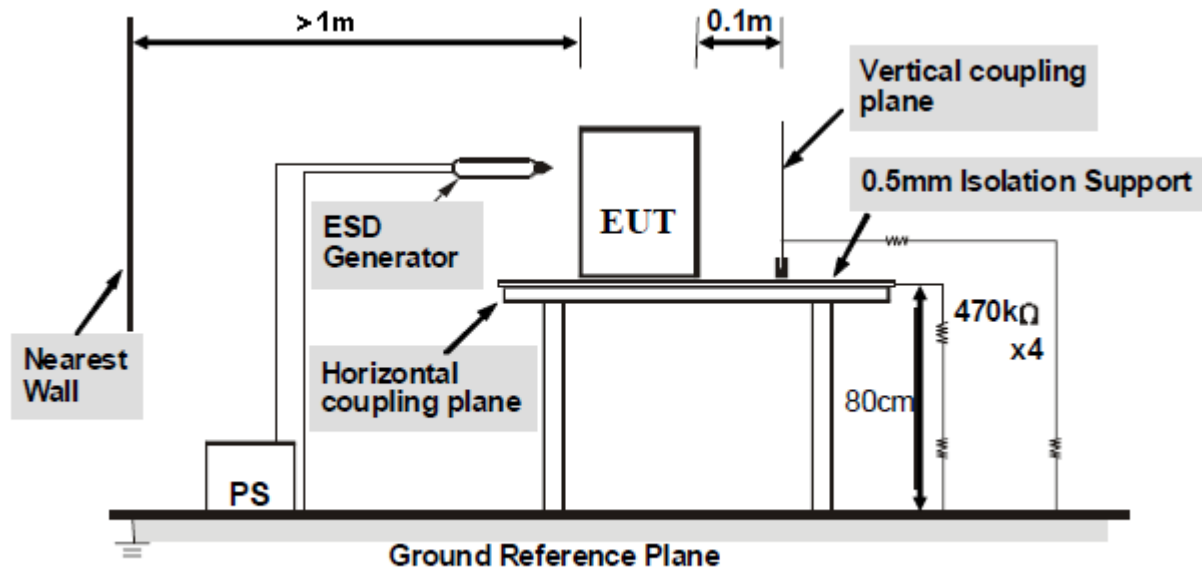

TEST PROCEDURE

Please refer to ETSI EN 301 489-1 Clause 9.3.2 , EN 55035 and EN 61000-4-2 for the measurement methods.

Contact Discharge:

The ESD generator is held perpendicular to the surface to which the discharge is applied and the tip of the discharge electrode touch the surface of EUT. Then turn the discharge switch. The generator is then re-triggered for a new single discharge and repeated at least 10 times for each pre-selected test point. This procedure shall be repeated until all the air discharge completed.

Air Discharge:

Air discharge is used where contact discharge can't be applied. The round discharge tip of the discharge electrode shall be approached as fast as possible to touch the EUT. After each discharge, the discharge electrode shall be removed from the EUT. The generator is then re-triggered for a new single discharge and repeated at least 10 times for each pre-selected test point. This procedure shall be repeated until all the air discharge completed.

Indirect discharge for horizontal coupling plane:

At least 10 single discharges shall be applied to the horizontal coupling plane, at points on each side of the EUT.

Indirect discharge for vertical coupling plane:

At least 10 single discharges shall be applied to the center of one vertical edge of the coupling plane. The coupling plane, of dimensions 0.5m X 0.5m, is placed parallel to, and positioned at a distance of 0.1m from



the EUT. Discharges shall be applied to the coupling plane, with this plane in sufficient different positions that the four faces of the EUT are completely illuminated.

TEST MODE

Please reference to the section 2.3

TEST RESULTS

Direct discharge				
Type of discharge	Discharge voltage (KV)	Observations Performance	Criteria Level	Result
Contact discharge	±2	No degradation in performance of the EUT was observed (A)	B	Pass
	±4	A	B	
Air discharge	±2	A	B	
	±4	A	B	
	±8	A	B	
Indirect discharge				
Type of discharge	Discharge voltage (KV)	Observations Performance	Criteria Level	Result
HCP (6 sides)	±2	A	B	Pass
	±4	A	B	
VCP (4 sides)	±2	A	B	
	±4	A	B	

Remark: The ancillary equipment's specification for an acceptable level of performance or degradation of performance during and/or after the ESD tests.



4.2.3. RF Electromagnetic Field

PERFORMANCE CRITERION

Criteria A

TEST LEVEL

3V/m (80%, 1kHz Amplitude Modulation)

TEST CONFIGURATION

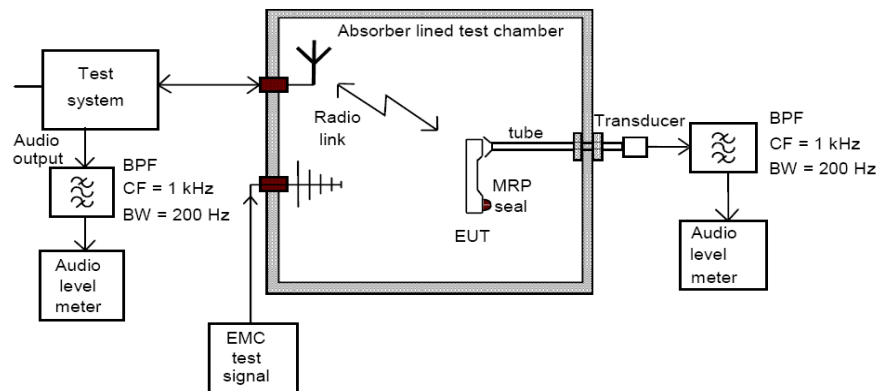

TEST PROCEDURE

Please refer to ETSI EN 301 489-1 Clause 9.2.2 and EN 61000-4-3 for the measurement methods.

TEST MODE

Please reference to the section 2.3

TEST RESULTS

Frequency	Level	Modulation	Antenna Polarization	EUT Face	Observations (Performance Criterion)	Result
80MHz-6GHz	3 V/m	1 kHz, 80 % Amp. Mod, 1 % increment, dwell time=3seconds	V	Front	A	Pass
			H		A	Pass
			V	Rear	A	Pass
			H		A	Pass
			V	Left	A	Pass
			H		A	Pass
			V	Right	A	Pass
			H		A	Pass
			V	Top	A	Pass
			H		A	Pass
			V	Bottom	A	Pass
			H		A	Pass

Remark: A: No degradation in performance of the EUT was observed.



4.2.4. Surges

PERFORMANCE CRITERION

Criteria B

TEST LEVEL

1kV Line to Line: Differential mode

2kV Line to Ground: Common mode

(Voltage Waveform: 1.2/50 us; Current Waveform: 8/20 us)

TEST CONFIGURATION

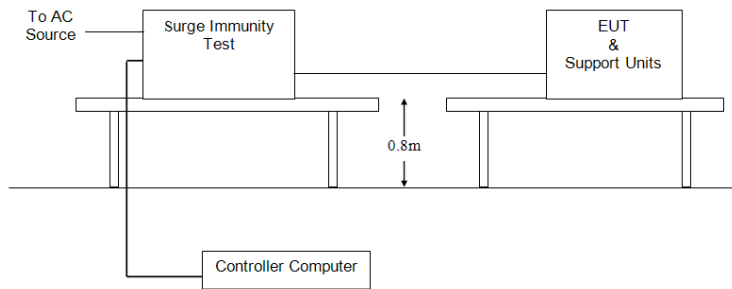

TEST PROCEDURE

Please refer to ETSI EN 301 489-1 Clause 9.8.2 and EN 61000-4-5 for the measurement methods.

TEST MODE

Please reference to the section 2.3

TEST RESULTS

For AC Mains :

Location	Level(kV)	Pulse No	Surge Interval	Phase(deg)	Observations (Performance Criterion)	Result
L-N	± 1	5	60s	0°	A	Pass
				90°	A	Pass
				180°	A	Pass
				270°	A	Pass

Remark: A: No degradation in performance of the EUT was observed.

For network port

Location	Level(kV)	Pulse No	Surge Interval	Observations (Performance Criterion)	Result
LAN Line to line	± 0.5K	5	60s	B	Pass



Remark: A: No degradation in performance of the EUT was observed.

4.2.5. RF- Common Mode 0.15MHz to 80MHz

PERFORMANCE CRITERION

Criteria A

TEST LEVEL

3Vrms on AC main port (80%, 1kHz Amplitude Modulation)

TEST CONFIGURATION

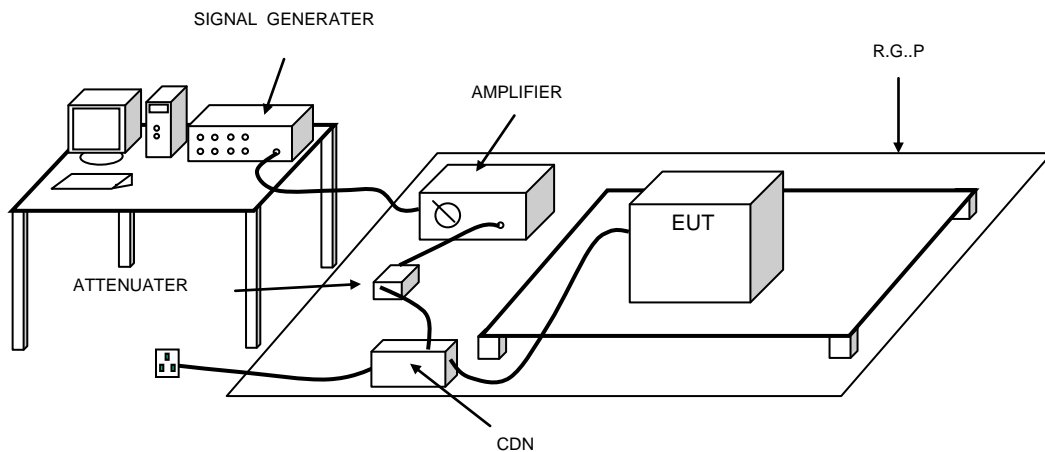

TEST PROCEDURE

Please refer to ETSI EN 301 489-1 Clause 9.5.2 and EN 61000-4-6 for the measurement methods.

TEST MODE

Please reference to the section 2.3

TEST RESULTS

TEST RESULTS

For Mains

Frequency	Injected Position	Coupling Direct/Clamp	Level	Modulation	Observations (Performance Criterion)	Result
150kHz to 80MHz	AC Mains	Direct	3Vrms	1 kHz, 80 % Amp. Mod, 1 % increment, dwell time=3seconds	A	Pass

Remark: A: No degradation in performance of the EUT was observed

For network Wire



Frequency	Injected Position	Coupling Direct/Clamp	Level	Modulation	Observations (Performance Criterion)	Result
150kHz to 80MHz	network Wire	Clamp	3Vrms	1 kHz, 80 % Amp. Mod, 1 % increment, dwell time=3seconds	A	Pass

Remark: A: No degradation in performance of the EUT was observed

4.2.6. Fast Transients Common Mode

PERFORMANCE CRITERION

Criteria B

TEST LEVEL

1KV for AC main port

(Impulse Frequency: 5 kHz; Tr/Th: 5/50ns; Burst Duration: 15ms; Burst Period: 3Hz)

TEST CONFIGURATION

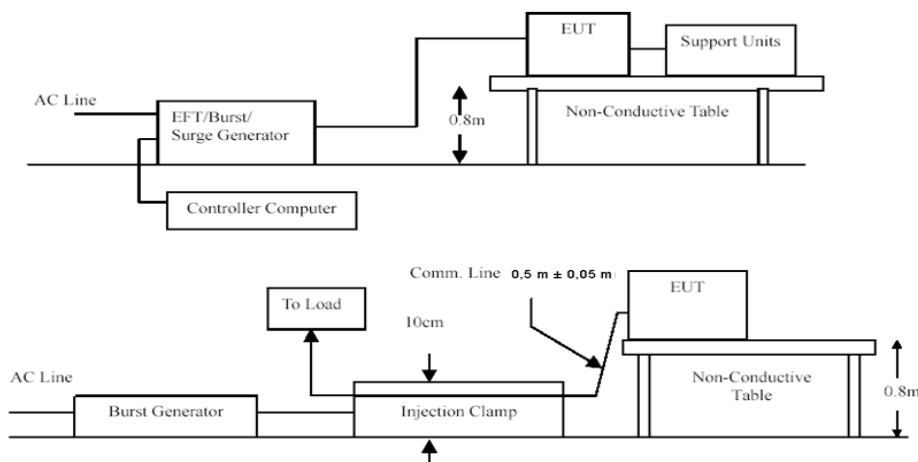

TEST PROCEDURE

Please refer to ETSI EN 301 489-1 Clause 9.4.2 , EN55035 and EN 61000-4-4 for the measurement methods.

TEST MODE

Please reference to the section 2.3

TEST RESULTS

For AC Mains

Lead under Test	Level (\pm kV)	Coupling Direct/Clamp	Observations (Performance Criterion)	Result
-----------------	-------------------	-----------------------	--------------------------------------	--------



L	±1	Direct	A	Pass
N	±1	Direct	A	Pass
L-N	±1	Direct	A	Pass

Remark: A: No degradation in performance of the EUT was observed

For network port

Lead under Test	Level (±kV)	Coupling Direct/Clamp	Observations (Performance Criterion)	Result
Network Wire	±0.5	Clamp	A	Pass

Remark: A: No degradation in performance of the EUT was observed.

4.2.7. Voltage Dips and Interruptions

PERFORMANCE CRITERION

>95% VD, 0.5 period----Performance criterion: B

>95% VD, 1.0 period----Performance criterion: B

30% VD, 25 period----Performance criterion: C

>95% VI, 250 period----Performance criterion: C

TEST LEVEL

0% of VT(Supply Voltage) for 0.5 period

0% of VT(Supply Voltage) for 1.0 period

70% of VT(Supply Voltage) for 25 period

0% of VT(Supply Voltage) for 250 period

TEST CONFIGURATION

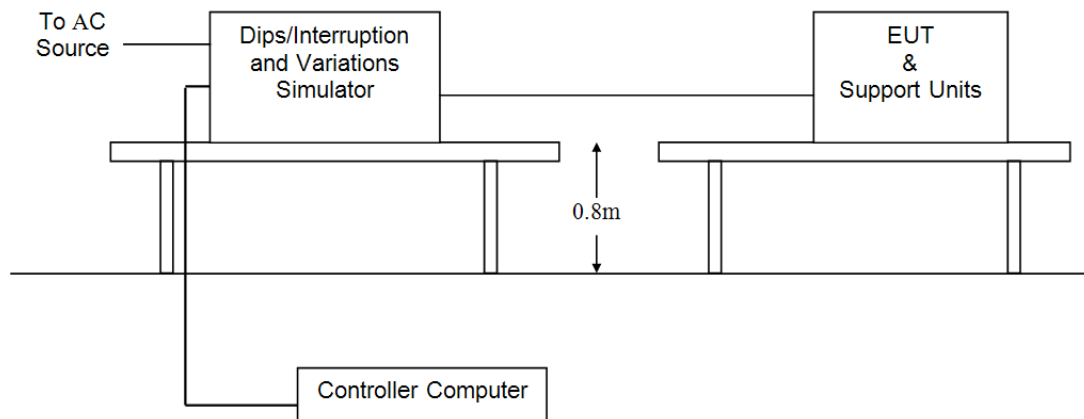

TEST PROCEDURE

Please refer to ETSI EN 301 489-1 Clause 9.7.2 and EN 61000-4-11 for the measurement methods.



TEST MODE

Please reference to the section 2.3

TEST RESULTS

Test Level % UT	Duration (Periods)	Phase angle	No. of drop out	Time between dropout	Observations (Performance Criterion)	Result
0	0.5	0°, 90°, 180°, 270°	3	10s	A	Pass
0	1.0	0°, 90°, 180°, 270°	3	10s	A	Pass
70	25	0°, 90°, 180°, 270°	3	10s	A	Pass
0	250	0°, 90°, 180°, 270°	3	10s	B	Pass

Remark :

A: No degradation in performance of the EUT was observed.

B: During the test, the power shut down, after the experiment, the function can automatically return to normal

5. Test Set-up Photos of the EUT

Radiated Emission (30MHz-1GHz)



Radiated Emission (Above 1GHz)



Conducted Emission





6. External and Internal Photos of the EUT

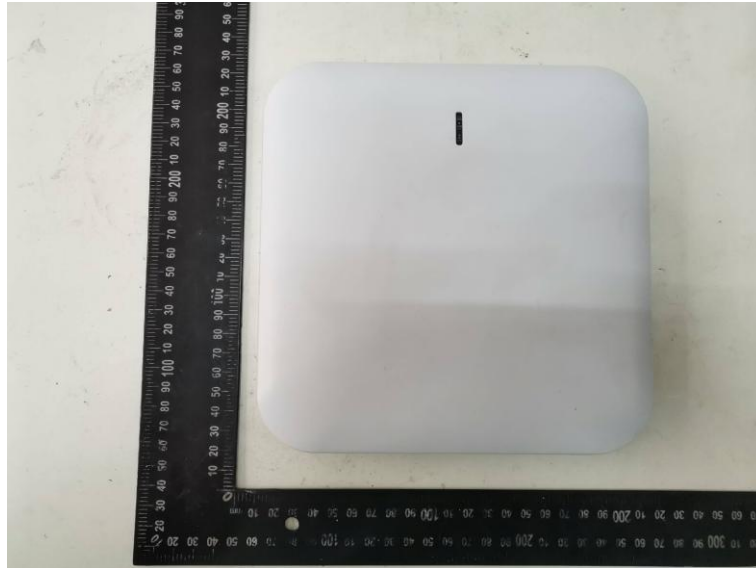



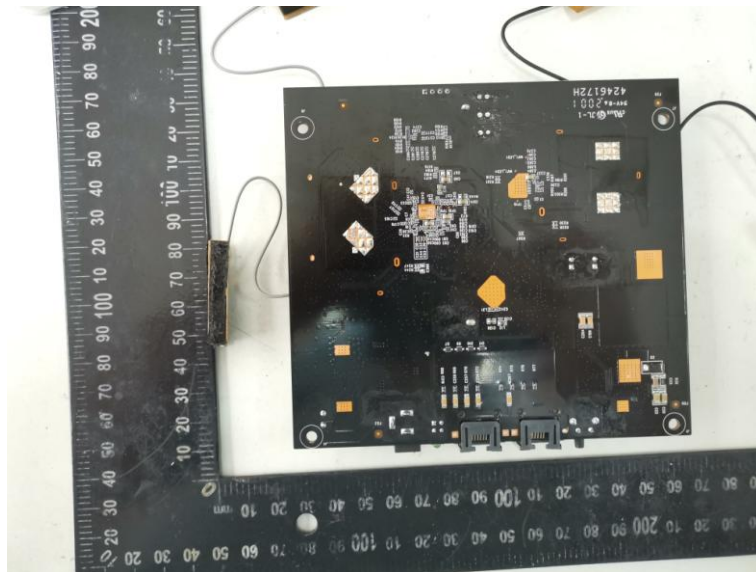
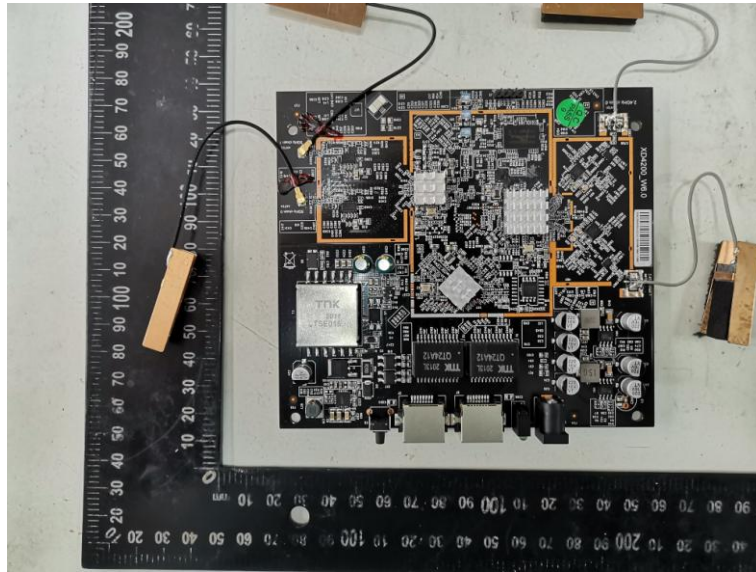

.....End of Report.....