



EMC TEST REPORT

Applicant's name.....: SHENZHEN ITOONER TECHNOLOGY CO., LTD
Building 2&Building 3(The 3rd and 4th Floor) GangZai
Address.....: Road,Shangxing Community,Xinqiao Street,Baoan District,
Shenzhen, Guangdong, China

Manufacture's Name.....: SHENZHEN ITOONER TECHNOLOGY CO., LTD
Building 2&Building 3(The 3rd and 4th Floor) GangZai
Address.....: Road,Shangxing Community,Xinqiao Street,Baoan District,
Shenzhen, Guangdong, China

Product description

Product name.....: PoE Media Converter
GNT-P2913AB,GNT-2903AB,GNT-2913AB,GNT-2915AB,
Model and/or type.....: GNT-2916AB,GNT-P2903AB,GNT-P2913AB,GNT-29XXAB,
reference: GNT-P29XXAB,GNT-G922SAB,GNT-G120SAB,GNT-G124SAB,
GNT-G150SAB,GNT-G152SAB,G122SAB,GNT-GXXXSAB

Standards.....: EN55032:2015+A1:2020+A11:2020
EN55035:2017+A11:2020+A11:2020

This device described above has been tested by YCT, and the test results show that the equipment under test (EUT) is in compliance with the 2014/30/EU requirements. And it is applicable only to the tested sample identified in the report.

This report shall not be reproduced except in full, without the written approval of YCT, this document may be altered or revised by YCT, personal only, and shall be noted in the revision of the document.

Date of Test.....:
Date (s) of performance of tests.....: Feb.22, 2022~ Dec.28, 2022
Date of Issue.....: Feb.28, 2022
Test Result.....: **Pass**

Testing Engineer : Jack Yu
(Jack Yu)
Technical Manager : Peter peng
(Peter peng)
Authorized Signatory : Jim he
(Jim he)

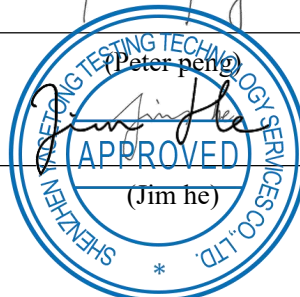



Equipment under Test : PoE Media Converter

Model /Type : GNT-P2913AB

Listed Models : GNT-2903AB,GNT-2913AB,GNT-2915AB,GNT-2916AB,
GNT-P2903AB,GNT-29XXAB,GNT-P29XXAB,GNT-G922SAB,
GNT-G120SAB,GNT-G124SAB,GNT-G150SAB,GNT-G152SAB,
GNT-GXXSAB

Applicant : SHENZHEN ITOONER TECHNOLOGY CO., LTD

Address : Building 2&Building 3(The 3rd and 4th Floor) GangZai
Road,Shangxing Community,Xinqiao Street,Baoan District,
Shenzhen, Guangdong, China

Manufacturer : SHENZHEN ITOONER TECHNOLOGY CO., LTD

Address : Building 2&Building 3(The 3rd and 4th Floor) GangZai
Road,Shangxing Community,Xinqiao Street,Baoan District,
Shenzhen, Guangdong, China

Test Result:	PASS
---------------------	-------------

The test report merely corresponds to the test sample.
It is not permitted to copy extracts of these test result without the written permission of the test laboratory.



TABLE OF CONTENT

	Page
Test Report Declaration	
1. GENERAL INFORMATION	5
1.1. Description of Device (EUT)	5
1.2. Tested System Details	5
1.3. Test Uncertainty	5
2. TEST INSTRUMENT USED	6
3. CONDUCTED EMISSION AT THE MAINS TERMINALS TEST	10
3.1. Block Diagram Of Test Setup	10
3.2. Test Standard	10
3.3. Power Line Conducted Emission Limit	10
3.4. EUT Configuration on Test	10
3.5. Operating Condition of EUT	10
3.6. Test Procedure	11
3.7. Test Result	11
4. RADIATION EMISSION TEST	12
4.1. Block Diagram of Test Setup	12
4.2. Test Standard	12
4.3. Radiation Limit	12
4.4. EUT Configuration on Test	13
4.5. Operating Condition of EUT	13
4.6. Test Procedure	13
4.7. Test Result	13
5. HARMONIC CURRENT EMISSION TEST	16
5.1. Block Diagram of Test Setup	16
5.2. Test Standard	16
5.3. Operating Condition of EUT	16
5.4. Test Procedure	16
5.5. Test Results	16
6. VOLTAGE FLUCTUATIONS & FLICKER TEST	17
6.1. Block Diagram of Test Setup	17
6.2. Test Standard	17
6.3. Operating Condition of EUT	17
6.4. Test Procedure	17
6.5. Test Results	17
7. ELECTROSTATIC DISCHARGE IMMUNITY TEST	18
7.1. Block Diagram of Test Setup	18
7.2. Test Standard	18
7.3. Severity Levels and Performance Criterion	18
7.4. EUT Configuration	19
7.5. Operating Condition of EUT	19
7.6. Test Procedure	19
7.7. Test Results	20
8. RF FIELD STRENGTH SUSCEPTIBILITY TEST	21
8.1. Block Diagram of Test Setup	21
8.2. Test Standard	21
8.3. Severity Levels and Performance Criterion	22
8.4. EUT Configuration on Test	22
8.5. Operating Condition of EUT	22



8.6.	Test Procedure.....	23
8.7.	Test Results.....	23
9.	ELECTRICAL FAST TRANSIENT/BURST IMMUNITY TEST.....	24
9.1.	Block Diagram of EUT Test Setup.....	24
9.2.	Test Standard.....	24
9.3.	Severity Levels and Performance Criterion.....	24
9.4.	EUT Configuration on Test.....	25
9.5.	Operating Condition of EUT.....	25
9.6.	Test Procedure.....	25
9.7.	Test Results.....	25
10.	SURGE TEST.....	26
10.1.	Block Diagram of EUT Test Setup.....	26
10.2.	Test Standard.....	26
10.3.	Severity Levels and Performance Criterion.....	26
10.4.	EUT Configuration on Test.....	27
10.5.	Operating Condition of EUT.....	27
10.6.	Test Procedure.....	27
10.7.	Test Result.....	27
11.	INJECTED CURRENTS SUSCEPTIBILITY TEST.....	28
11.1.	Block Diagram of EUT Test Setup.....	28
11.2.	Test Standard.....	28
11.3.	Severity Levels and Performance Criterion.....	28
11.4.	EUT Configuration on Test.....	29
11.5.	Operating Condition of EUT.....	29
11.6.	Test Procedure.....	29
11.7.	Test Result.....	30
12.	MAGNETIC FIELD IMMUNITY TEST.....	31
12.1.	Block Diagram of Test Setup.....	31
12.2.	Test Standard.....	31
12.3.	Severity Levels and Performance Criterion.....	31
12.4.	EUT Configuration on Test.....	32
12.5.	Operating Condition of EUT.....	32
12.6.	Test Procedure.....	32
12.7.	Test Results.....	32
13.	VOLTAGE DIPS AND INTERRUPTIONS TEST.....	33
13.1.	Block Diagram of EUT Test Setup.....	33
13.2.	Test Standard.....	33
13.3.	Severity Levels and Performance Criterion.....	33
13.4.	EUT Configuration on Test.....	34
13.5.	Operating Condition of EUT.....	34
13.6.	Test Procedure.....	34
13.7.	Test Result.....	34
14.	EUT PHOTOGRAPHS.....	36



1. GENERAL INFORMATION

1.1. Description of Device (EUT)

EUT	: PoE Media Converter
Trademark	: N/A
Model Number	: GNT-P2913AB, GNT-2903AB, GNT-2913AB, GNT-2915AB, GNT-2916AB, GNT-P2903AB, GNT-29XXAB, GNT-P29XXAB, GNT-G922SAB, GNT-G120SAB, GNT-G124SAB, GNT-G150SAB, GNT-G152SAB, GNT-GXXSAB
Model Difference	: Apart from the name of the model, the others are the same
Power Supply	: 5-12Vdc, 0.4-1A

Note: SK-HDMI to RGB+ USB to IIC was selected as the test model and the datas have been recorded in this report.

1.2. Tested System Details

Personal Computer	: ASUS
M/N	: GNT-P2913AB

1.3. Test Uncertainty

Conducted Emission Uncertainty : ± 2.66 dB

Radiated Emission Uncertainty : ± 4.26 dB



2. T INSTRUMENT USED

For Conducted Emission at the mains terminals Test

Conducted Emission Test (A --- site)					
Equipment	Manufacturer	Model#	Serial#	Last Cal.	Next Cal.
843 Shielded Room	ChengYu	843 Room	843	July. 14, 2021	July. 13, 2022
EMI Receiver	R&S	ESCI	101421	July. 14, 2021	July. 13, 2022
LISN	Schwarzbeck	NSLK8127	8127739	July. 14, 2021	July. 13, 2022
Attenuator	R&S	ESH3-Z2	021E	July. 14, 2021	July. 13, 2022
843 Cable 1#	FUJIKURA	843C1#	001	July. 14, 2021	July. 13, 2022

For Conducted Emission at the telecom port Test

Conducted Emission Test (A --- site)					
Equipment	Manufacturer	Model#	Serial#	Last Cal.	Next Cal.
843 Shielded Room	ChengYu	843 Room	843	July. 14, 2021	July. 13, 2022
EMI Receiver	R&S	ESCI	101421	July. 14, 2021	July. 13, 2022
Coupling/ Decoupling Network	PH	ISN T800	S1509001	July. 14, 2021	July. 13, 2022
Attenuator	R&S	ESH3-Z2	021E	July. 14, 2021	July. 13, 2022
843 Cable 1#	FUJIKURA	843C1#	001	July. 14, 2021	July. 13, 2022

For Radiated Emission Test



Radiation Emission Test (966 chamber)					
Equipment	Manufacturer	Model#	Serial#	Last Cal.	Next Cal.
966 chamber	ChengYu	966 Room	966	July. 14, 2021	July. 13, 2022
Spectrum Analyzer	Agilent	E4407B	MY4510957 2	July. 14, 2021	July. 13, 2022
Amplifier	Schwarzbeck	BBV9743	9743-119	July. 14, 2021	July. 13, 2022
Amplifier	Schwarzbeck	BBV9718	9718-270	July. 14, 2021	July. 13, 2022
Log-periodic Antenna	Schwarzbeck	VULB9160	VULB9160 -3369	July. 14, 2021	July. 13, 2022
EMI Receiver	R&S	ESCI	101421	July. 14, 2021	July. 13, 2022
Horn Antenna	Schwarzbeck	BBHA9120D	9120D-127 5	July. 14, 2021	July. 13, 2022
966 Cable 1#	CHENGYU	966	004	July. 14, 2021	July. 13, 2022
966 Cable 2#	CHENGYU	966	003	July. 14, 2021	July. 13, 2022

For Harmonic & Flicker Test

For Harmonic / Flicker Test (A --- site)					
Equipment	Manufacturer	Model#	Serial#	Last Cal.	Next Cal.
Harmonic / Flicker Analyzer	KIKUSUI	KHA1000	VA002445	July. 14, 2021	July. 13, 2022
AC Power Supply	KIKUSUI	PCR4000M	UK001879	July. 14, 2021	July. 13, 2022
Line Impedance network	KIKUSUI	LIN1020JF	UL001611	July. 14, 2021	July. 13, 2022

For Electrostatic Discharge Immunity Test

For Electrostatic Discharge Immunity Test (A --- site)					
Equipment	Manufacturer	Model#	Serial#	Last Cal.	Next Cal.
ESD Tester	KIKUSUI	KES4201A	UH002321	July. 14, 2021	July. 13, 2022

For RF Field Strength Susceptibility Test(SMQ)

For RF Field Strength Susceptibility Test (SMQ --- site)					
Equipment	Manufacturer	Model#	Serial#	Last Cal.	Next Cal.
Signal Generator	HP	8648A	3625U00573	July. 14, 2021	July. 13, 2022
Amplifier	A&R	500A100	17034	July. 14, 2021	July. 13, 2022
Amplifier	A&R	100W/1000M1	17028	July. 14, 2021	July. 13, 2022
Audio Analyzer	Panasonic	2023B	202301/428	July. 14, 2021	July. 13, 2022



(20Hz~1GHz)					
Isotropic Field Probe	A&R	FP2000	16755	July. 14, 2021	July. 13, 2022
Antenna	EMCO	3108	9507-2534	July. 14, 2021	July. 13, 2022
Log-periodic Antenna	A&R	AT1080	16812	July. 14, 2021	July. 13, 2022



For Electrical Fast Transient /Burst Immunity Test

For Electrical Fast Transient/Burst Immunity Test (A --- site)					
Equipment	Manufacturer	Model#	Serial#	Last Cal.	Next Cal.
Burst Tester	Prima	EFT61004AG	PR14054467	July. 14, 2021	July. 13, 2022
Coupling Clamp	Prima	EFT61004AG	009E	July. 14, 2021	July. 13, 2022

For Surge Test

For Surge Test (A --- site)					
Equipment	Manufacturer	Model#	Serial#	Last Cal.	Next Cal.
Surge Tester	Prima	SUG61005BX	PR12045446	July. 14, 2021	July. 13, 2022

For Injected Currents Susceptibility Test

For Injected Currents Susceptibility Test (A --- site)					
Equipment	Manufacturer	Model#	Serial#	Last Cal.	Next Cal.
C/S Test System	SCHLODER	CDG600	126B1281	July. 14, 2021	July. 13, 2022
CDN	SCHLODER	CDN-M2+3	A2210320/2015	July. 14, 2021	July. 13, 2022
Injection Clamp	SCHLOBER	EMCL-20	132A1214/2015	July. 14, 2021	July. 13, 2022

For Magnetic Field Immunity Test

For Magnetic Field Immunity Test (A --- site)					
Equipment	Manufacturer	Model#	Serial#	Last Cal.	Next Cal.
Magnetic field generator	HTEC	HPFMF	15701	July. 14, 2021	July. 13, 2022

For Voltage Dips Interruptions Test

For Voltage Dips Interruptions Test (A --- site)					
Equipment	Manufacturer	Model#	Serial#	Last Cal.	Next Cal.
Dips Tester	Prima	DRP61011AG	PR14086284	July. 14, 2021	July. 13, 2022



3. CONDUCTED EMISSION AT THE MAINS TERMINALS TEST

3.1. Block Diagram Of Test Setup

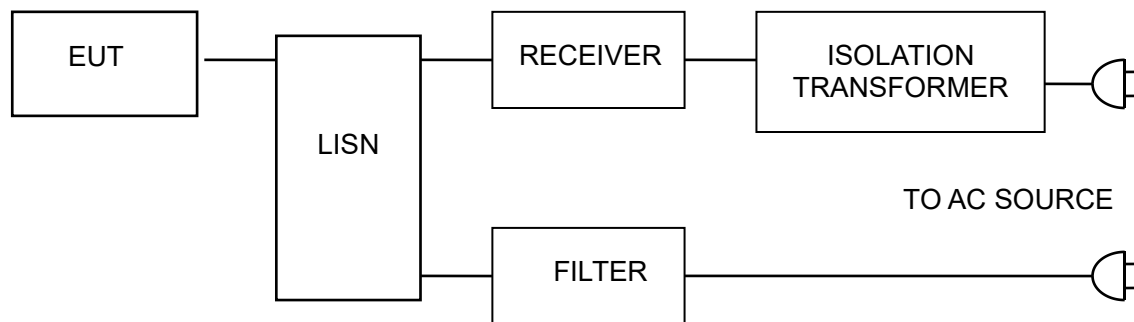

3.2. Test Standard

EN55032:2015+A1:2020+A11:2020

3.3. Power Line Conducted Emission Limit

Frequency MHz	Limits dB(μV)	
	Quasi-peak Level	Average Level
0.15 ~ 0.50	66 ~ 56*	56 ~ 46*
0.50 ~ 5.00	56	46
5.00 ~ 30.00	60	50

Notes: 1. *Decreasing linearly with logarithm of frequency.
 2. The lower limit shall apply at the transition frequencies.

3.4. EUT Configuration on Test

The following equipments are installed on conducted emission test to meet EN 55032 requirement and operating in a manner which tends to maximize its emission characteristics in a normal application.

3.5. Operating Condition of EUT

- 3.5.1 Setup the EUT and simulators as shown in Section 3.1.
- 3.5.2 Turn on the power of all equipments.
- 3.5.3 Let the EUT work in test modes and test it.



3.6. Test Procedure

The EUT is put on the ground and connected to the AC mains through a Artificial Mains Network (AMN). This provided a 50ohm coupling impedance for the tested equipments. Both sides of AC line are checked to find out the maximum conducted emission levels according to the **EN 55032** regulations during conducted emission test.

The bandwidth of the test receiver (R&S Test Receiver ESCI) is set at 10KHz.

The frequency range from 150 KHz to 30 MHz is investigated.

3.7. Test Result

The EUT is powered by the DC only, the test item is not applicable.



4. RADIATION EMISSION TEST

4.1. Block Diagram of Test Setup

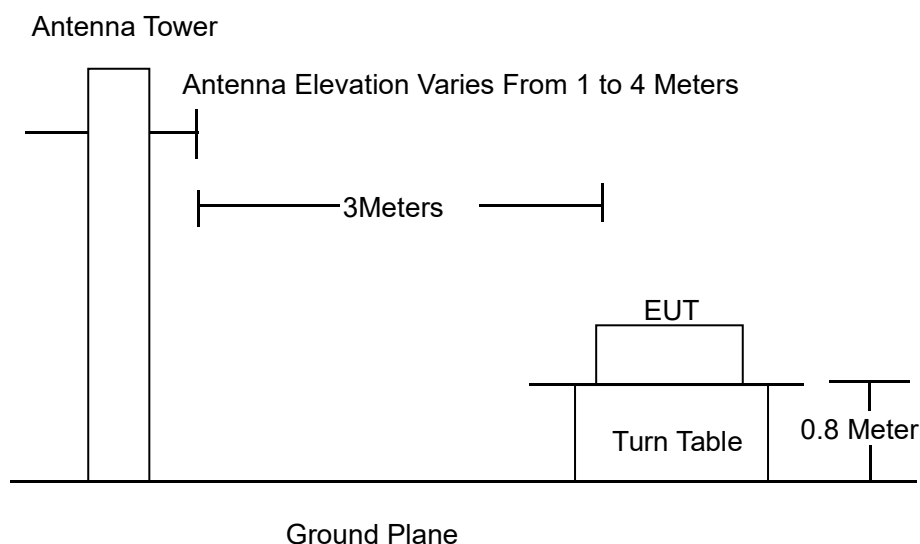

4.2. Test Standard

EN55032:2015+A1:2020+A11:2020

4.3. Radiation Limit

Frequency MHz	Distance (Meters)	Field Strengths Limits dB(μ V)/m	Detector
30 ~ 230	3	40.0	QP
230 ~ 1000	3	47.0	QP
1000 ~ 3000	3	76.0	PEAK
1000 ~ 3000	3	56.0	AVERAGE
3000 ~ 6000	3	80.0	PEAK
3000 ~ 6000	3	60.0	AVERAGE

Remark:

- (1) Emission level (dB(μ V)/m) = 20 log Emission level (μ V/m)
- (2) The smaller limit shall apply at the cross point between two frequency bands.
- (3) Distance refers to the distance in meters between the measuring instrument, antenna and the closed point of any part of the device or system.



4.4.EUT Configuration on Test

The EN 55032 regulations test method must be used to find the maximum emission during radiated emission test.

The configuration of EUT is the same as used in conducted emission test. Please refer to Section 2.2.

4.5.Operating Condition of EUT

Same as conducted emission test, which is listed in Section 2.2 except the test set up replaced as Section 4.1.

4.6.Test Procedure

The EUT and its simulators are placed on a turned table that is 0.8 meter above the ground. The turned table can rotate 360 degrees to determine the position of the maximum emission level. The EUT is set 3 meters away from the receiving antenna that is mounted on the antenna tower. The antenna can move up and down between 1 meter and 4 meters to find out the maximum emission level. Broadband antenna (calibrated biconical and log periodical antenna) is used as receiving antenna. Both horizontal and vertical polarization of the antenna is set on test. In order to find the maximum emission levels, the interface cable must be manipulated according to EN 55032 on radiated emission test.

The bandwidth setting on the field strength meter (R&S Test Receiver ESCI) is set at 120KHz below 1GHz, set at 1MHz above 1GHz

The frequency range from 30MHz to 1000MHz is checked.

The highest frequency of the internal sources of the EUT was below 108MHz, so the measurement was only made up to 1GHz.

4.7.Test Result

PASS

Please refer to the following page.



Radiation Emission Test Data			
Temperature:	24.5 °C	Relative Humidity:	54%
Pressure:	1009hPa	Phase :	Horizontal
Test Voltage :	DC5V	Test Mode:	ON Mode

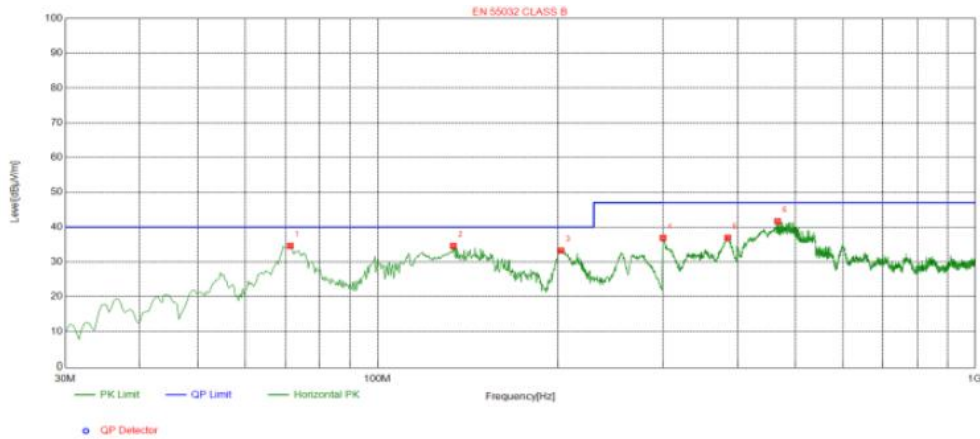

Suspected List

Suspected List									
NO.	Freq. [MHz]	Factor [dB]	Reading [dBµV/m]	Level [dBµV/m]	Limit [dBµV/m]	Margin [dB]	Height [cm]	Angle [°]	Polarity
1	71.4005	-17.92	52.50	34.58	40.00	5.42	100	348	Horizontal
2	133.8246	-18.80	53.36	34.56	40.00	5.44	100	255	Horizontal
3	202.7176	-14.99	48.23	33.24	40.00	6.76	100	112	Horizontal
4	300.3968	-12.73	49.61	36.88	47.00	10.12	100	0	Horizontal
5	385.4618	-10.73	47.66	36.93	47.00	10.07	100	290	Horizontal
6	466.9690	-8.44	50.11	41.67	47.00	5.33	100	136	Horizontal



Radiation Emission Test Data			
Temperature:	24.5 °C	Relative Humidity:	54%
Pressure:	1009hPa	Phase :	Vertical
Test Voltage :	DC5V	Test Mode:	ON Mode

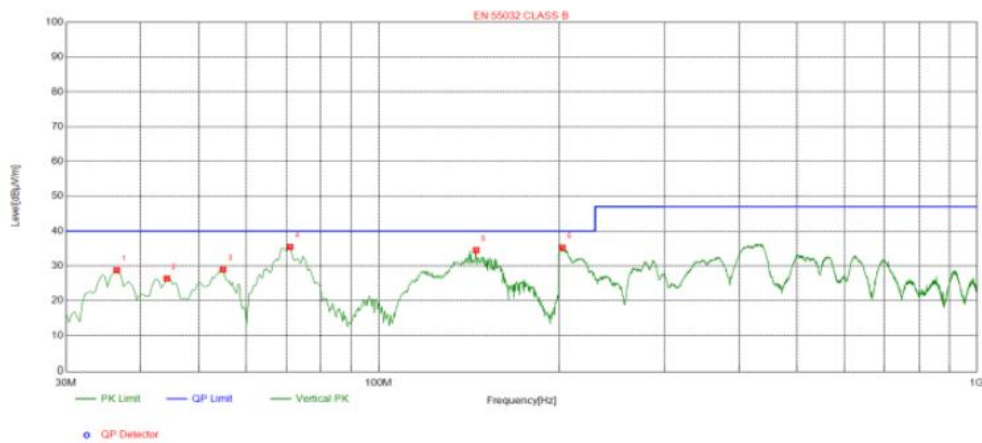

Suspected List

Suspected List									
NO.	Freq. [MHz]	Factor [dB]	Reading [dBµV/m]	Level [dBµV/m]	Limit [dBµV/m]	Margin [dB]	Height [cm]	Angle [°]	Polarity
1	36.4688	-15.67	44.40	28.73	40.00	11.27	100	12	Vertical
2	44.2314	-13.79	40.15	26.36	40.00	13.64	100	219	Vertical
3	54.9050	-14.39	43.32	28.93	40.00	11.07	100	223	Vertical
4	71.0770	-17.86	53.29	35.43	40.00	4.57	100	62	Vertical
5	145.4685	-19.05	53.56	34.51	40.00	5.49	100	244	Vertical
6	202.7176	-14.99	50.24	35.25	40.00	4.75	100	19	Vertical



5. HARMONIC CURRENT EMISSION TEST

5.1. Block Diagram of Test Setup

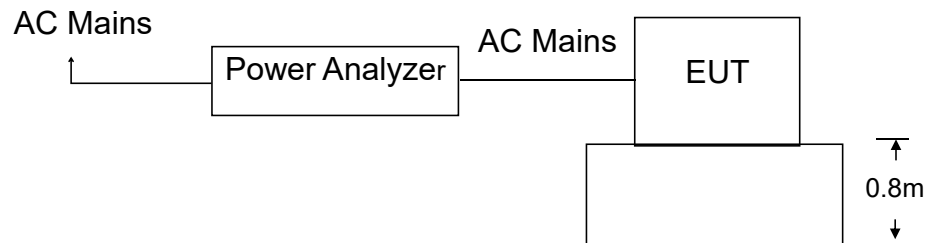

5.2. Test Standard

EN 61000-3-2:2014

5.3. Operating Condition of EUT

5.3.1 Setup the EUT as shown in Section 5.1.

5.3.2 Turn on the power of all equipments.

5.3.3 Let the EUT work in test mode and test it.

5.4. Test Procedure

The power cord of the EUT is connected to the output of the test system. Turn on the power of the EUT and use the test system to test the harmonic current level.

5.5. Test Results

The EUT is powered by the DC only, the test item is not applicable.



6. VOLTAGE FLUCTUATIONS & FLICKER TEST

6.1. Block Diagram of Test Setup

Same as Section 6.1..

6.2. Test Standard

EN 61000-3-3:2013

6.3. Operating Condition of EUT

Same as Section 5.3.. The power cord of the EUT is connected to the output of the test system. Turn on the power of the EUT and use the test system to test the harmonic current level.

Flicker Test Limit

Test items	Limits
Pst	1.0
dc	3.3%
dmax	4.0%
dt	Not exceed 3.3% for 500ms

6.4. Test Procedure

The power cord of the EUT is connected to the output of the test system. Turn on the power of the EUT and use the test system to test the harmonic current level.

6.5. Test Results

The EUT is powered by the DC only, the test item is not applicable.



7. ELECTROSTATIC DISCHARGE IMMUNITY TEST

7.1. Block Diagram of Test Setup

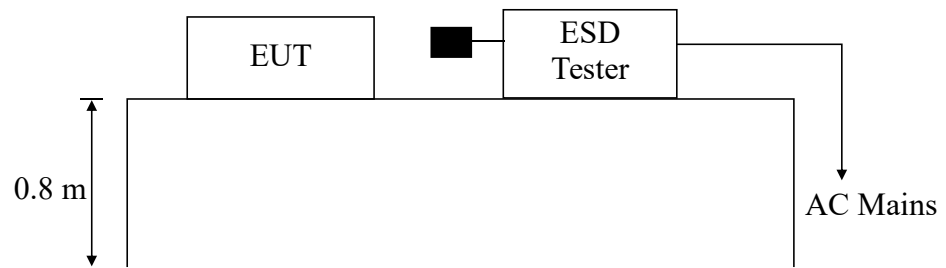

7.2. Test Standard

EN55035:2017+A11:2020, EN 61000-4-2:2009

Severity Level: 3 / Air Discharge: ± 8 KV
Level: 2 / Contact Discharge: ± 4 KV

7.3. Severity Levels and Performance Criterion

7.3.1 Severity level

Level	Test Voltage Contact Discharge (KV)	Test Voltage Air Discharge (KV)
1.	± 2	± 2
2.	± 4	± 4
3.	± 6	± 8
4.	± 8	± 15
X	Special	Special



7.3.2 Performance criterion : B

- A. The apparatus shall continue to operate as intended during and after the test. No degradation of performance or loss of function is allowed below a performance level specified by the manufacturer, when the apparatus is used as intended.
- B. The apparatus shall continue to operate as intended after the test. No degradation of performance or loss of function is allowed below a performance level specified by the manufacturer, when the apparatus is used as intended. The performance level may be replaced by a permissible loss of performance. During the test, degradation of performance is however allowed.
- C. Temporary loss of function is allowed, provided the function is self-recoverable or can be restored by the operation of the controls.

7.4.EUT Configuration

The following equipments are installed on Electrostatic Discharge Immunity test to meet EN55035:2017+A11:2020, EN 61000-4-2:2009, requirement and operating in a manner which tends to maximize its emission characteristics in a normal application. The configuration of EUT is the same as used in conducted emission test.

Please refer to Section 2.4.

7.5.Operating Condition of EUT

Same as conducted emission measurement, which is listed in Section 3.5 except the test setup replaced by Section 7.1.2.

7.6.Test Procedure

7.6.1 Air Discharge:

This test is done on a non-conductive surface. The round discharge tip of the discharge electrode shall be approached as fast as possible to touch the EUT. After each discharge, the discharge electrode shall be removed from the EUT. The generator is then re-triggered for a new single discharge and repeated 10 times for each pre-selected test point. This procedure shall be repeated until all the air discharge completed.

7.6.2 Contact Discharge:

All the procedure shall be same as Section 7.6.1. Except that the tip of the discharge electrode shall touch the EUT before the discharge switch is operated.

7.6.3 Indirect discharge for horizontal coupling plane

At least 10 single discharges (in the most sensitive polarity) shall be applied at the front edge of each HCP opposite the center point of each unit (if



applicable) of the EUT and 0.1m from the front of the EUT. The long axis of the discharge electrode shall be in the plane of the HCP and perpendicular to its front edge during the discharge.

7.6.4 Indirect discharge for vertical coupling plane

At least 10 single discharges (in the most sensitive polarity) shall be applied to the center of one vertical edge of the coupling plane. The coupling plane, of dimensions 0.5m X 0.5m, is placed parallel to, and positioned at a distance of 0.1m from the EUT. Discharges shall be applied to the coupling plane, with this plane in sufficient different positions that the four faces of the EUT are complete illuminated.

7.7. Test Results

PASS

Please refer to the following page.

ESD Test Data				
Temperature:	24.5°C	Humidity:	53%	
Power Supply :	DC5V	Test Mode:	On	
Air Discharge: ± 8KV				
Contact Discharge: ± 4KV				
# For each point positive 25 times and negative 25 times discharge				
Test Points	Air Discharge	Contact Discharge	Performance Criterion	Result
Enclosure	±2,4,8KV	N/A	B	PASS
Slit	±2,4,8KV	N/A	B	PASS
Metal Part	N/A	±2,4 KV	B	PASS
VCP	N/A	±2,4 KV	B	PASS
HCP	N/A	±2,4 KV	B	PASS
Note: N/A				



8. RF FIELD STRENGTH SUSCEPTIBILITY TEST

8.1. Block Diagram of Test Setup

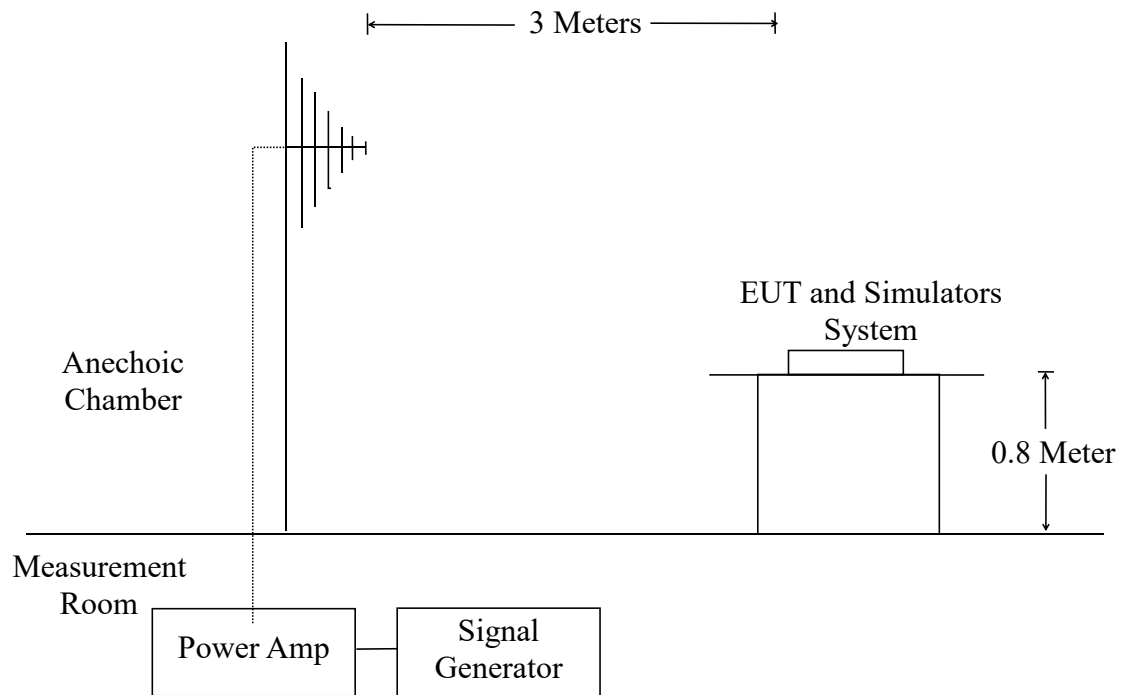

8.2. Test Standard

EN55035:2017+A11:2020, EN 61000-4-3: 2006+A1:2008+A2:2010
Severity Level 2, 3V / m



8.3. Severity Levels and Performance Criterion

8.3.1. Severity level

Level	Field Strength V/m
1.	1
2.	3
3.	10
X.	Special

8.3.2. Performance criterion: A

- A、 The apparatus shall continue to operate as intended during and after the test. No degradation of performance or loss of function is allowed below a performance level specified by the manufacturer, when the apparatus is used as intended.
- B、 The apparatus shall continue to operate as intended after the test. No degradation of performance or loss of function is allowed below a performance level specified by the manufacturer, when the apparatus is used as intended. The performance level may be replaced by a permissible loss of performance. During the test, degradation of performance is however allowed.
- C、 Temporary loss of function is allowed, provided the function is self-recoverable or can be restored by the operation of the controls.

8.4. EUT Configuration on Test

The following equipments are installed on Electrical Fast Transient/Burst Immunity test to meet EN55035:2017+A11:2020, EN 61000-4-4:2012, requirement and operating in a manner which tends to maximize its emission characteristics in a normal application. The configuration of EUT is the same as used in conducted emission test.

Please refer to Section 3.4.

8.5. Operating Condition of EUT

Same as conducted emission measurement, which is listed in Section 2.5 except the test setup replaced by Section 8.1.



8.6. Test Procedure

The EUT and its simulators are placed on a turn table which is 0.8 meter above ground. EUT is set 3 meter away from the transmitting antenna which is mounted on an antenna tower. Both horizontal and vertical polarization of the antenna are set on test. Each of the four sides of EUT must be faced this transmitting antenna and measured individually.

All the scanning conditions are as follows:

Condition of Test	Remarks
1. Fielded Strength	3 V/m (Severity Level 2)
2. Radiated Signal	Modulated
3. Scanning Frequency	80 – 1000 MHz
4. Dwell time of radiated	0.0015 decade/s
5. Waiting Time	1 Sec.

8.7. Test Results

PASS

Please refer to the following page.

R/S Test Data			
Temperature : 25°C		Humidity : 53%	
Field Strength: 3 V/m		Criterion: A	
Power Supply: DC5V		Frequency Range: 80 MHz to 1000 MHz	
Modulation: <input checked="" type="checkbox"/> AM <input type="checkbox"/> Pulse <input type="checkbox"/> none 1 KHz 80%			
Test Mode : On			
Frequency Range : 80-1000MHz			
Steps 1 %			
	Horizontal	Vertical	Result
Front	A	A	Pass
Right	A	A	Pass
Rear	A	A	Pass
Left	A	A	Pass
Note: N/A			



9. ELECTRICAL FAST TRANSIENT/BURST IMMUNITY TEST

9.1. Block Diagram of EUT Test Setup

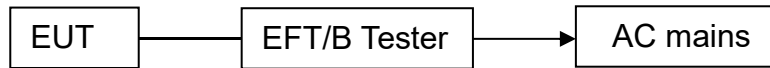

9.2. Test Standard

EN55035:2017+A11:2020, EN 61000-4-4:2012

9.3. Severity Levels and Performance Criterion

Severity Level 2 at 1KV, Pulse Rise time & Duration: 5 nS / 50 nS
Severity Level:

Open Circuit Output Test Voltage $\pm 10\%$		
Level	On power ports	On I/O(Input/Output) Signal data and control ports
1.	0.5KV	0.25KV
2.	1KV	0.5KV
3.	2KV	1KV
4.	4KV	2KV
X.	Special	Special

Performance criterion: B

- A. The apparatus shall continue to operate as intended during and after the test. No degradation of performance or loss of function is allowed below a performance level specified by the manufacturer, when the apparatus is used as intended.
- B. The apparatus shall continue to operate as intended after the test. No degradation of performance or loss of function is allowed below a performance level specified by the manufacturer, when the apparatus is used as intended. The performance level may be replaced by a permissible loss of performance. During the test, degradation of performance is however allowed.
- C. Temporary loss of function is allowed, provided the function is self-recoverable or can be restored by the operation of the controls.



9.4.EUT Configuration on Test

The following equipments are installed on Electrical Fast Transient/Burst Immunity test to meet EN55035:2017+A11:2020, EN 61000-4-4:2012, requirement and operating in a manner which tends to maximize its emission characteristics in a normal application. The configuration of EUT is the same as used in conducted emission test. Please refer to Section 3.4.

9.5.Operating Condition of EUT

Same as conducted emission measurement, which is listed in Section 2.6 except the test setup replaced by Section 9.1.

9.6.Test Procedure

EUT shall be placed 0.8m high above the ground reference plane which is a min.1m*1m metallic sheet with 0.65mm minimum thickness. This reference ground plane shall project beyond the EUT by at least 0.1m on all sides and the minimum distance between EUT and all other conductive structure, except the ground plane beneath the EUT, shall be more than 0.5m

9.6.1. For input and output AC power ports:

The EUT is connected to the power mains by using a coupling device which couples the EFT interference signal to AC power lines. Both polarities of the test voltage should be applied during compliance test and the duration of the test is 2 minutes.

9.7.Test Results

The EUT is powered by the DC only, the test item is not applicable.



10. SURGE TEST

10.1. Block Diagram of EUT Test Setup

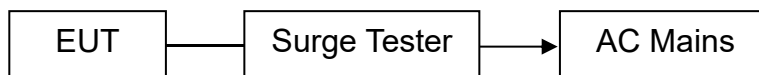

10.2. Test Standard

EN55035:2017+A11:2020, EN61000-4-5:2014

10.3. Severity Levels and Performance Criterion

Severity Level: Line to Line, Level 2 at 1KV;

Severity Level: Line to Earth, Level 3 at 2KV.

Severity Level	Open-Circuit Test Voltage (KV)
1.	0.5
2.	1.0
3.	2.0
4.	4.0
X.	Special

Performance criterion: B

- A. The apparatus shall continue to operate as intended during and after the test. No degradation of performance or loss of function is allowed below a performance level specified by the manufacturer, when the apparatus is used as intended.
- B. The apparatus shall continue to operate as intended after the test. No degradation of performance or loss of function is allowed below a performance level specified by the manufacturer, when the apparatus is used as intended. The performance level may be replaced by a permissible loss of performance. During the test, degradation of performance is however allowed.
- C. Temporary loss of function is allowed, provided the function is self-recoverable or can be restored by the operation of the controls.



10.4. EUT Configuration on Test

The following equipments are installed on Electrical Fast Transient/Burst Immunity test to meet EN55035:2017+A11:2020, EN61000-4-5:2014, requirement and operating in a manner which tends to maximize its emission characteristics in a normal application

The configuration of EUT is the same as used in conducted emission test. Please refer to Section 3.4.

10.5. Operating Condition of EUT

Same as conducted emission measurement, which is listed in Section 2.7 except the test setup replaced by Section 10.1.

10.6. Test Procedure

- 1) Set up the EUT and test generator as shown on section 10.1
- 2) For line to line coupling mode, provide a 1KV 1.2/50us voltage surge (at open-circuit condition) and 8/20us current surge to EUT selected points.
- 3) At least 5 positive and 5 negative (polarity) tests with a maximum 1/min repetition rate are conducted during test.
- 4) Different phase angles are done individually.
- 5) Repeat procedure 2) to 4) except the open-circuit test voltage change from 1KV to 2KV for line to earth coupling mode test.
- 6) Record the EUT operating situation during compliance test and decide the EUT immunity criterion for above each test.

10.7. Test Result

The EUT is powered by the DC only, the test item is not applicable.



11. INJECTED CURRENTS SUSCEPTIBILITY TEST

11.1. Block Diagram of EUT Test Setup

11.1.1. Block Diagram of EUT Test Setup

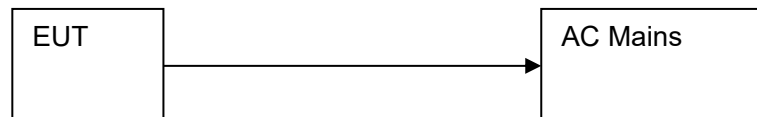

11.1.2. Block Diagram of Test Setup

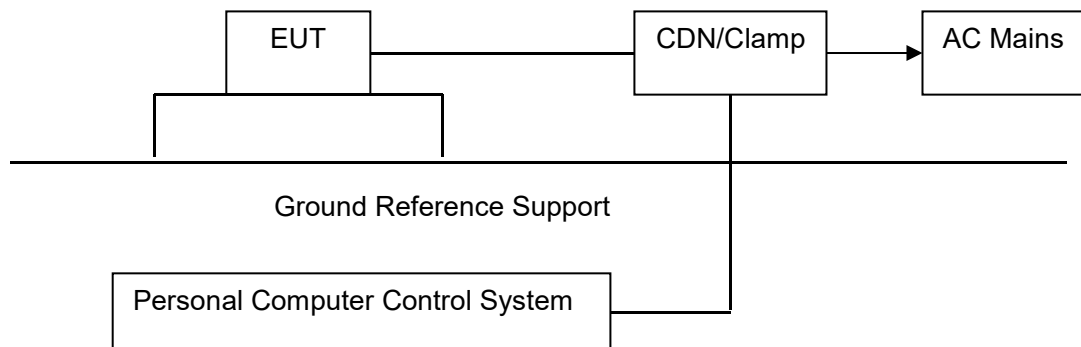

11.2. Test Standard

EN55035:2017+A11:2020, EN61000-4-6:2014

11.3. Severity Levels and Performance Criterion

Severity Level 2: 3V(rms), 150KHz ~ 80MHz

Severity Level:

Level	Field Strength V
1.	1
2.	3
3.	10
X.	Special



Performance criterion: A

- A. The apparatus shall continue to operate as intended during and after the test. No degradation of performance or loss of function is allowed below a performance level specified by the manufacturer, when the apparatus is used as intended.
- B. The apparatus shall continue to operate as intended after the test. No degradation of performance or loss of function is allowed below a performance level specified by the manufacturer, when the apparatus is used as intended. The performance level may be replaced by a permissible loss of performance. During the test, degradation of performance is however allowed.
- C. Temporary loss of function is allowed, provided the function is self-recoverable or can be restored by the operation of the controls.

11.4. EUT Configuration on Test

The configuration of EUT is the same as used in conducted emission test. Please refer to Section 2.8.

11.5. Operating Condition of EUT

Same as conducted emission test, which is listed in Section 2.8 except the test set up replaced as Section 11.1.

11.6. Test Procedure

- 1) Set up the EUT, CDN and test generator as shown on section 11.1
- 2) Let EUT work in test mode and measure.
- 3) The EUT and supporting equipments are placed on an insulating support 0.1m high above a ground reference plane. CDN (coupling and decoupling device) is placed on the ground plane at above 0.1-0.3m from EUT. Cables between CDN and EUT are as short as possible, and their height above the ground reference plane shall be between 30 and 50 mm (where possible).
- 4) The disturbance signal described below is injected to EUT through CDN.
- 5) The EUT operates within its operational mode(s) under intended climatic conditions after power on.
- 6) The frequency range is swept from 150KHz to 80MHz using 3V signal level, and with the disturbance signal 80% amplitude modulated with a 1KHz sine wave



- 7) The rate of sweep shall not exceed 1.5×10^{-3} decades/s. Where the frequency is swept incrementally, the step size shall not exceed 1% of the start and thereafter 1% of the preceding frequency value.
- 8) Recording the EUT operating situation during compliance test and decide the EUT immunity criterion for above each test.

11.7. Test Result

The EUT is powered by the DC only, the test item is not applicable.



12. MAGNETIC FIELD IMMUNITY TEST

12.1. Block Diagram of Test Setup

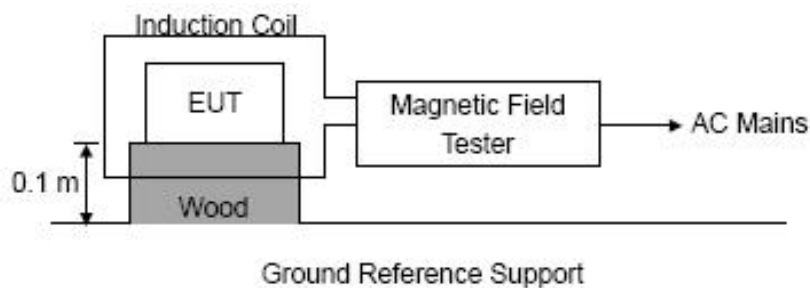

12.2. Test Standard

EN55035:2017+A11:2020, EN61000-4-8:2010
Severity Level 1 at 1A/m

12.3. Severity Levels and Performance Criterion

12.3.1 Severity level

Level	Magnetic Field Strength A/m
1.	1
2.	3
3.	10
4.	30
5.	100
X.	Special

12.3.2 Performance criterion: B

- A. The apparatus shall continue to operate as intended during and after the test. No degradation of performance or loss of function is allowed below a performance level specified by the manufacturer, when the apparatus is used as intended.
- B. The apparatus shall continue to operate as intended after the test. No degradation of performance or loss of function is allowed below a performance level specified by the manufacturer, when the apparatus



is used as intended. The performance level may be replaced by a permissible loss of performance. During the test, degradation of performance is however allowed.

- C. Temporary loss of function is allowed, provided the function is self-recoverable or can be restored by the operation of the controls.

12.4. EUT Configuration on Test

The configuration of EUT is listed in Section 2.9.

12.5. Operating Condition of EUT

Same as conducted emission test, which is listed in Section 2.9 except the test set up replaced as Section 12.1.

12.6. Test Procedure

The EUT shall be subjected to the test magnetic field by using the induction coil of standard dimensions (1m*1m) and shown in Section 10.1. The induction coil shall then be rotated by 90° in order to expose the EUT to the test field with different orientations.

12.7. Test Results

The EUT is powered by the DC only, the test item is not applicable.



13. VOLTAGE DIPS AND INTERRUPTIONS TEST

13.1. Block Diagram of EUT Test Setup

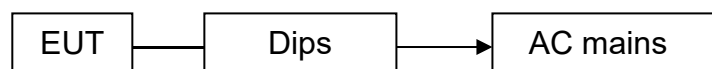

13.2. Test Standard

EN55035:2017+A11:2020, EN61000-4-11:2004

13.3. Severity Levels and Performance Criterion

Severity Level:

Input and Output AC Power Ports.

Voltage Dips.

Voltage Interruptions.

Environmental Phenomena	Test Specification	Units	Performance Criterion
Voltage Dips	>95 0.5	% Reduction period	B
	30 25	% Reduction period	C
Voltage Interruptions	>95 250	% Reduction period	C

Performance criterion: B, C, C

- A. The apparatus shall continue to operate as intended during and after the test. No degradation of performance or loss of function is allowed below a performance level specified by the manufacturer, when the apparatus is used as intended.
- B. The apparatus shall continue to operate as intended after the test. No degradation of performance or loss of function is allowed below a performance level specified by the manufacturer, when the apparatus is used as intended. The performance level may be replaced by a



permissible loss of performance. During the test, degradation of performance is however allowed.

- C. Temporary loss of function is allowed, provided the function is self-recoverable or can be restored by the operation of the controls.

13.4. EUT Configuration on Test

The configuration of EUT is the same as used in conducted emission test. Please refer to Section 2.10.

13.5. Operating Condition of EUT

Same as conducted emission test, which is listed in Section 2.10 except the test set up replaced as Section 13.1.

13.6. Test Procedure

- 1) Set up the EUT and test generator as shown on section 13.1
- 2) The interruption is introduced at selected phase angles with specified duration. There is a 3mins minimum interval between each test event.
- 3) After each test a full functional check is performed before the next test.
- 4) Repeat procedures 2 & 3 for voltage dips, only the level and duration is changed.
- 5) Record any degradation of performance.

13.7. Test Result

The EUT is powered by the DC only, the test item is not applicable.



TEST Photographs

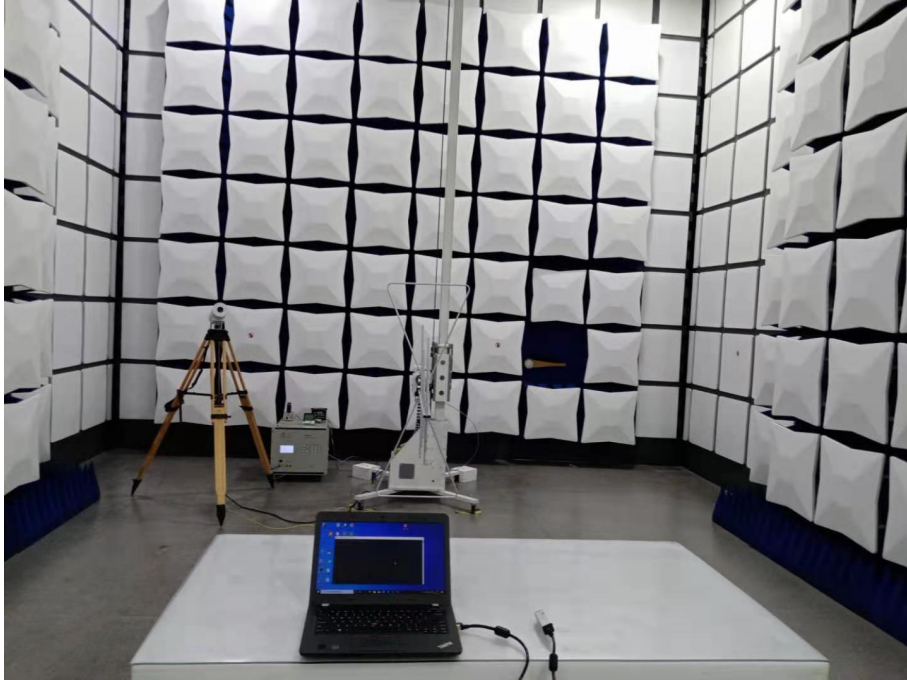



14. EUT PHOTOGRAPHS

EUT Photo 1

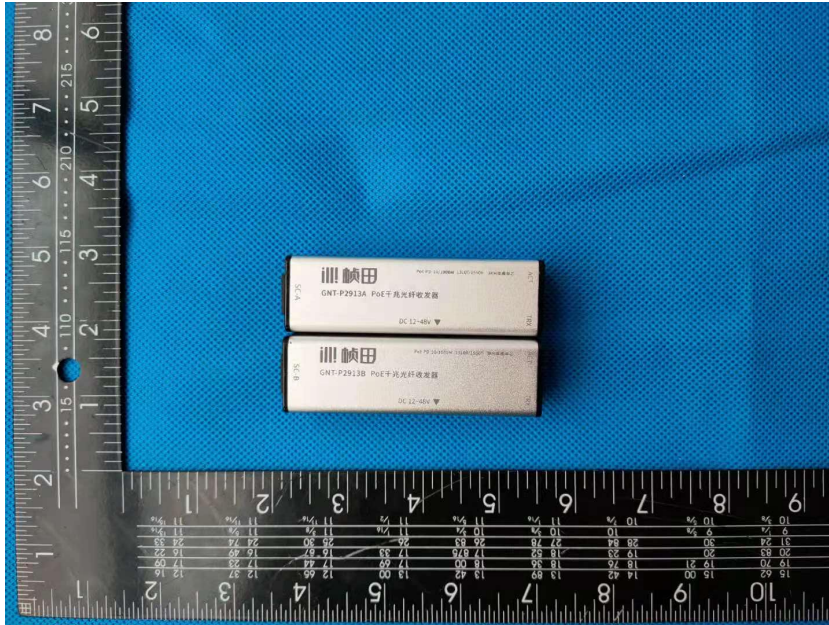

EUT Photo 2

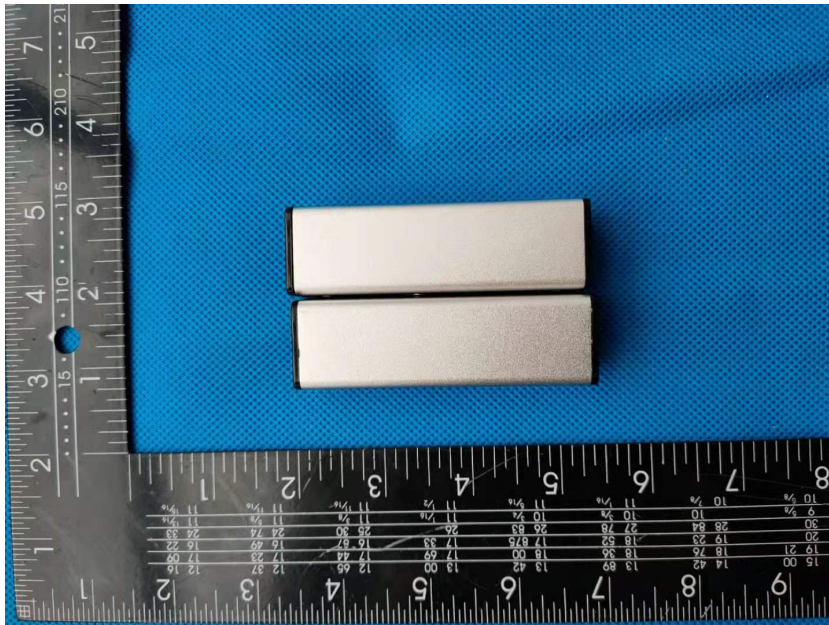



EUT Photo 3

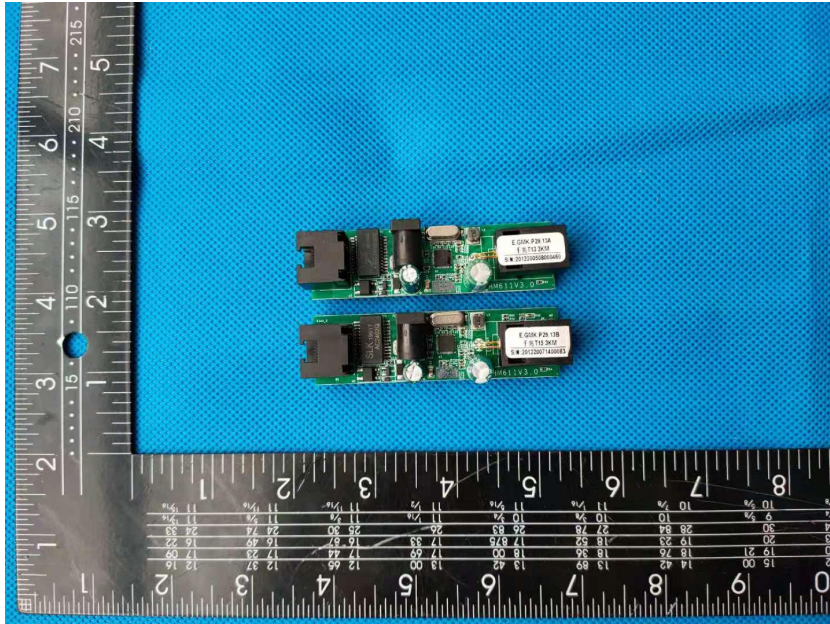

EUT Photo 4

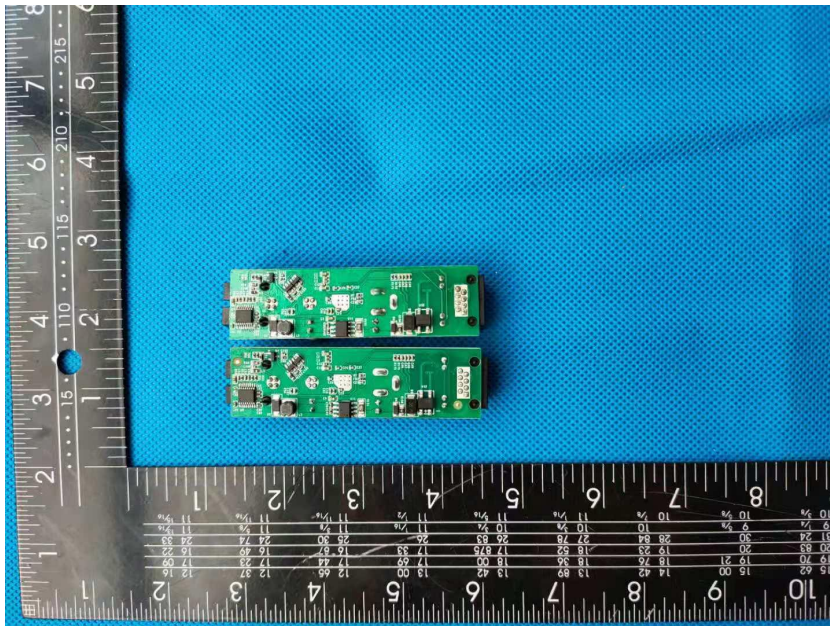

***** END OF REPORT *****