

2-Wire System DT595A Audio door Station

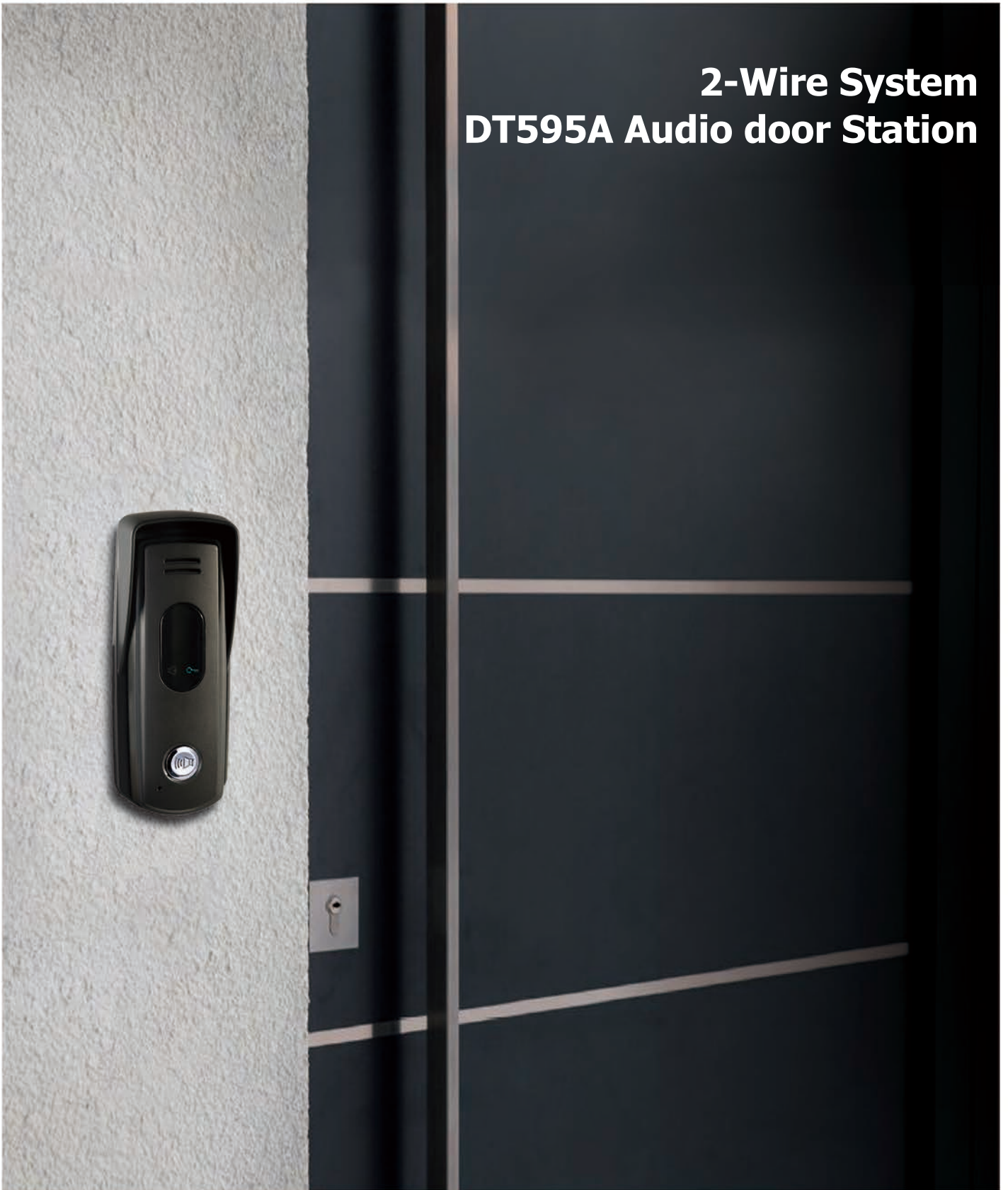

V-TEK



DT-CAM

- SONY CCD
- High waterproof and weatherproof
- 15M IR Distance



ACTUAL SIZE

DT595A

- Waterproof mounting hook
- Zinc alloy housing
- Status indicator area
- Metal Call Button
- Microphone

2-Wire Outdoor Station



Full Zinc Alloy Casting

- Compact Zinc alloy design
- Vandalism and cauterization



Waterproof & Dustproof

- IP55 rate design
- Excellent performance



Security & Protection

- Anti-theft screw mounting
- 30° angle bracket for option

Dimensions

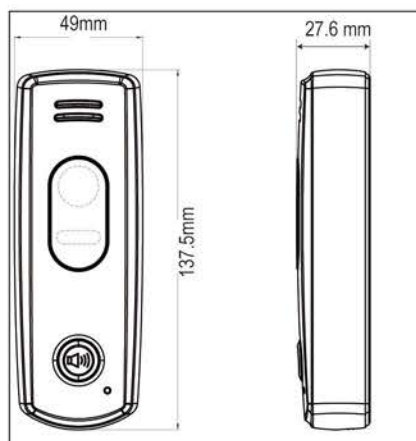

Mounting

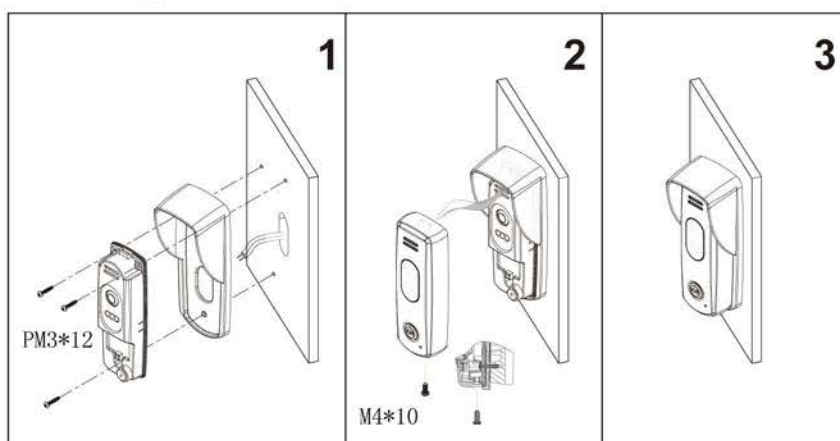

Connection with DT-CAM wiring mode

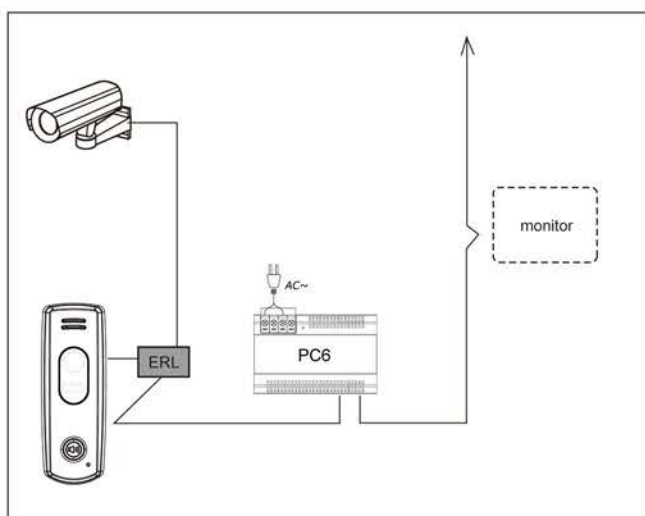

Due to continuous product improvement, the brochure can be changed without notice. Right to interpret and copyright will be preserved. Only for downloads from the Internet.
Sep 2012 | Art No. 12092103 version 1.0

Guangzhou Video-Tech Electronics Co., Ltd

V-TEC

F6/No.7 building, Huangzhou Industrial Area
Chebei Road, TianHe district, Guangzhou, China

T +86/20/38601218

F +86/20/38628806

www.v-tec.cn