

## EC DECLARATION OF CONFORMITY FOR MACHINES (DIRECTIVE 98/37/EC)

**Manufacturer:** FAAC S.p.A.

**Address:** Via Benini, 1 - 40069 Zola Predosa BOLOGNA - ITALY

**Declares that:** The operator mod. **844 R Reversible**

- is built to be integrated into a machine or to be assembled with other machinery to create a machine under the provisions of Directive 98/37/EC;
- conforms to the essential safety requirements of the following EEC directives:

73/23/EEC and subsequent amendment 93/68/EEC.  
89/336/EEC and subsequent amendment 92/31/EEC and 93/68/EEC

and also declares that it is prohibited to put into service the machinery until the machine in which it will be integrated or of which it will become a component has been identified and declared as conforming to the conditions of Directive 98/37/EC.

Bologna, 01 January 2005

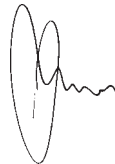

### WARNINGS FOR THE INSTALLER GENERAL SAFETY OBLIGATIONS

- 1) **ATTENTION! To ensure the safety of people, it is important that you read all the following instructions. Incorrect installation or incorrect use of the product could cause serious harm to people.**
- 2) Carefully read the instructions before beginning to install the product.
- 3) Do not leave packing materials (plastic, polystyrene, etc.) within reach of children as such materials are potential sources of danger.
- 4) Store these instructions for future reference.
- 5) This product was designed and built strictly for the use indicated in this documentation. Any other use, not expressly indicated here, could compromise the good condition/operation of the product and/or be a source of danger.
- 6) FAAC declines all liability caused by improper use or use other than that for which the automated system was intended.
- 7) Do not install the equipment in an explosive atmosphere: the presence of inflammable gas or fumes is a serious danger to safety.
- 8) The mechanical parts must conform to the provisions of Standards EN 12604 and EN 12605.  
For non-EU countries, to obtain an adequate level of safety, the Standards mentioned above must be observed, in addition to national legal regulations.
- 9) FAAC is not responsible for failure to observe Good Technique in the construction of the closing elements to be motorised, or for any deformation that may occur during use.
- 10) The installation must conform to Standards EN 12453 and EN 12445.  
For non-EU countries, to obtain an adequate level of safety, the Standards mentioned above must be observed, in addition to national legal regulations.
- 11) Before attempting any job on the system, cut out electrical power.
- 12) The mains power supply of the automated system must be fitted with an all-pole switch with contact opening distance of 3mm or greater. Use of a 6A thermal breaker with all-pole circuit break is recommended.
- 13) Make sure that a differential switch with threshold of 0.03 A is fitted upstream of the system.
- 14) Make sure that the earthing system is perfectly constructed, and connect metal parts of the means of the closure to it.
- 15) The safety devices (EN 12978 standard) protect any danger areas against **mechanical movement Risks**, such as crushing, dragging, and shearing.
- 16) Use of at least one indicator-light (e.g. FAACLIGHT) is recommended for every system, as well as a warning sign adequately secured to the frame structure, in addition to the devices mentioned at point "15".
- 17) FAAC declines all liability as concerns safety and efficient operation of the automated system, if system components not produced by FAAC are used.
- 18) For maintenance, strictly use original parts by FAAC.
- 19) Do not in any way modify the components of the automated system.
- 20) The installer shall supply all information concerning manual operation of the system in case of an emergency, and shall hand over to the user the warnings handbook supplied with the product.
- 21) Do not allow children or adults to stay near the product while it is operating.
- 22) Keep remote controls or other pulse generators away from children, to prevent the automated system from being activated involuntarily.
- 23) Transit through the leaves is allowed only when the gate is fully open.
- 24) The user must not attempt any kind of repair or direct action whatever and contact qualified personnel only.
- 25) Maintenance: check at least every 6 months the efficiency of the system, particularly the efficiency of the safety devices (including, where foreseen, the operator thrust force) and of the release devices.
- 26) **Anything not expressly specified in these instructions is not permitted.**

# 844 R Reversible AUTOMATED SYSTEM

These instructions apply to the following models:

## 844 R Reversible

The 844 R Reversible FAAC automated system for sliding gates is an electro-mechanical operator which transmits movement to the sliding leaf via a rack and pinion appropriately coupled to the gate.

The reversible system enables the gate to be moved manually when the motor is not operating. Consequently, an electric lock must be installed to ensure locking during closure.

The gearmotor is equipped with an adjustable mechanical clutch which makes it possible to adjust the thrust force exerted on the gate.

A handy manual release facility makes it possible to move the gate in the event of mechanical problems with the gearmotor. The electronic control unit can be housed inside the operator (462DF) together with the installation kit, or in a separate enclosure (578D or 462DF) - see chapter 5.

**The 844 Reversible automated system was designed and built for controlling vehicle access. Do not use for any other purpose.**

## 1. DESCRIPTION AND TECHNICAL SPECIFICATIONS

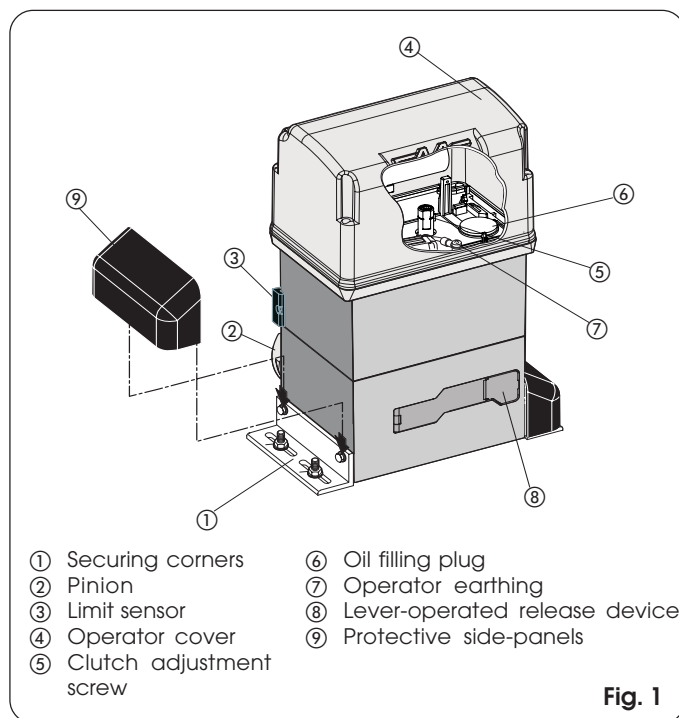

Fig. 1

### 1.1. MAXIMUM USE CURVE

The curve makes it possible to establish maximum work time (T) according to use frequency (F).

E.g.: The 844R Rev. gearmotor can operate non-stop at a use frequency of 70%.

To ensure efficiency operation, operate in the work range under the curve.

**Important:** The curve is obtained at a temperature of 24°C. Exposure to the direct sun rays can reduce use frequency down to 50%.

#### Calculation of use frequency

The percentage of effective work time (opening + closing) compared to total time of cycle (opening + closing + pause times).

Calculation formula:

$$\%F = \frac{Ta + Tc}{Ta + Tc + Tp + Ti} \times 100$$

where:

Ta = opening time

Tc = closing time

Tp = pause time

Ti = time interval between one complete cycle and another

### Use frequency graph

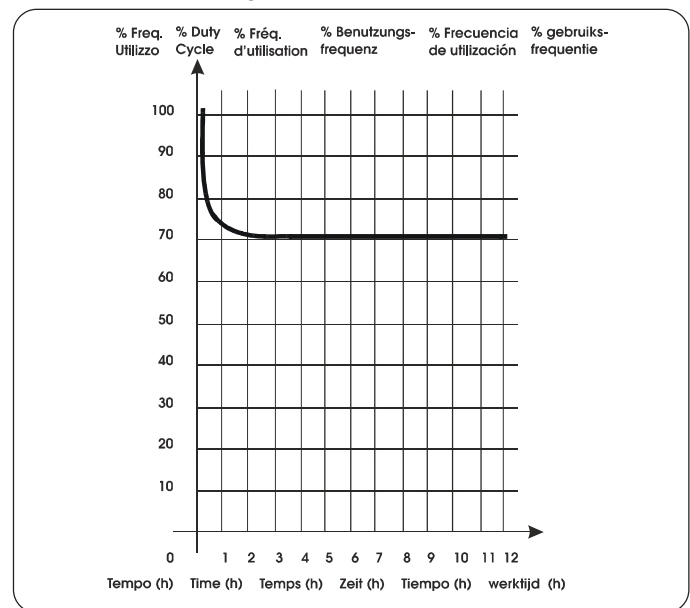

Tab. 1 TECHNICAL SPECIFICATIONS OF GEARMOTOR 844R REV.

MODEL	844R Reversible
Powersupply (Vac +6% -10% 50-60Hz)	230
Absorbed power (W)	550
Reduction ratio	1 : 10
Type of pinion	Z12
Rack	module 4 pitch 12.566
Max. thrust (daN)	68
Max. torque (Nm)	18
Winding thermal protection (°C)	140
Use frequency	70% (see graph)
Oil quantity (l)	1.8
Type of oil	FAAC XD 220
Operating ambient temperature (°C)	-20 to +55
Weight of gearmotor (Kg)	15
Protection class	IP 44
Gate max. weight (Kg)	1000
Gate speed (m/min)	11.6
Gate max. length (m) (time-out)	48
Clutch	twin-disk in oil bath
Protective treatment	cataphoresis
Available units	578 D - 462 DF
Limit-switch	M L S
Gearmotor overall dimensions LxHxD (mm)	see Fig. 2
Electric motor technical specifications	
RPM	750
Power (W)	550
Absorbed current (A)	2.5
Thrust capacitor (µF)	25
Powersupply (Vac +6% -10% 50-60Hz)	230

## 2. DIMENSIONS

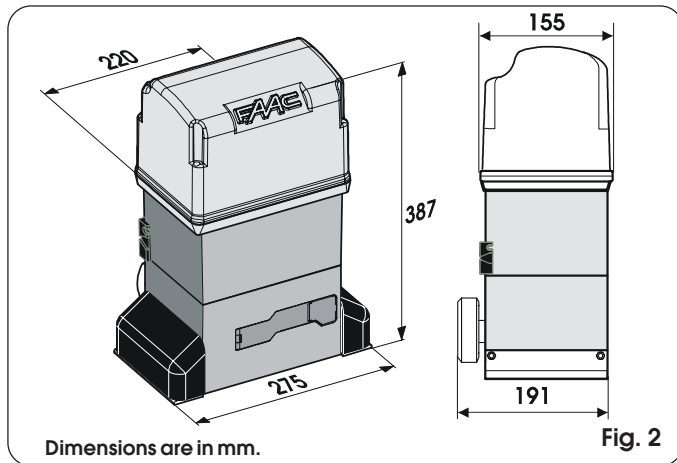

Fig. 2

## 3. ELECTRIC SET-UP

The 844R Rev. operator can be installed using a remote or on-board unit.

### 3.1. 578D or 462DF REMOTE UNIT

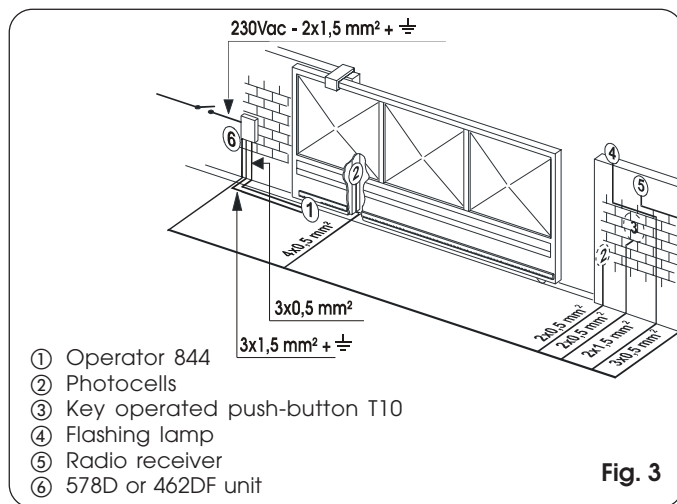

Fig. 3

### 3.2. 462DF ON-BOARD UNIT

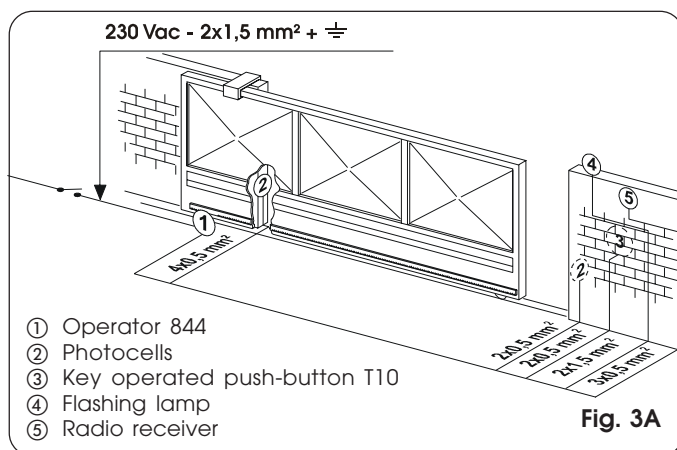

Fig. 3A

## 4. INSTALLING THE AUTOMATED SYSTEM

### 4.1. PRELIMINARY CHECKS

To ensure safety and an efficiently operating automated system, make sure the following conditions are observed:

- The structure of the gate must be suitable to be automated.

Specifically: the wheel diameter must be in relation to the weight of the gate to be automated; an upper guide must be present; mechanical travel stops must be fitted to prevent the gate derailing.

- The soil must permit sufficient stability for the foundation plinth.
- There must be no pipes or electric cables in the plinth excavation area.
- If the gearmotor is exposed to passing vehicles, install, if possible, adequate means of protection against accidental impact.
- Check if an efficient earth socket is available for connecting the gearmotor.

### 4.2. MASONRY FOR FOUNDATION PLATE

- 1) Assemble the foundation plate as in Fig. 4.
- 2) The foundation plate must be located as shown in Fig. 5 (right closing) or Fig. 6 (left closing) to ensure correct meshing between rack and pinion.
- 3) Make a foundation plinth as shown in Fig. 7 and wall the foundation plate, providing one or more sheaths for routing the electric cables. Using a spirit level, check if the plate is perfectly level. Wait for the cement to set.
- 4) Lay the electric cables for connection to the accessories and the electric power supply as shown in Fig. 3 or 3A: To facilitate making the connections, make the cables come out by about 40 cm from the foundation plate hole (Fig. 5-6 ref. ①).

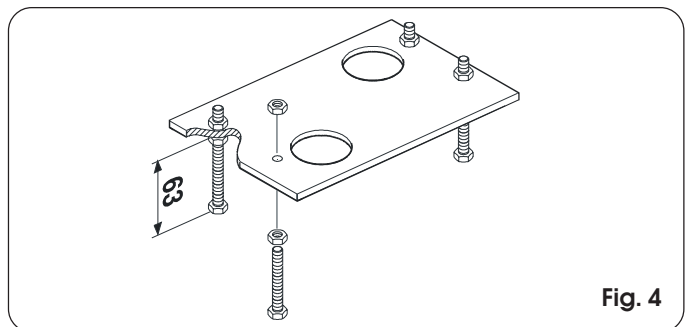

Fig. 4

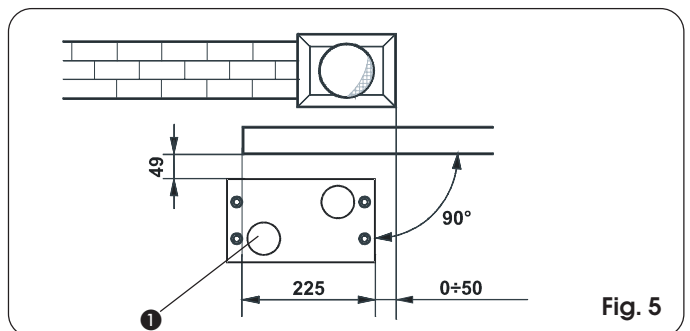

Fig. 5

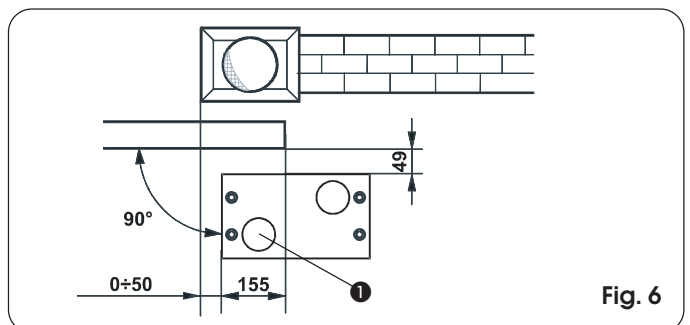

Fig. 6

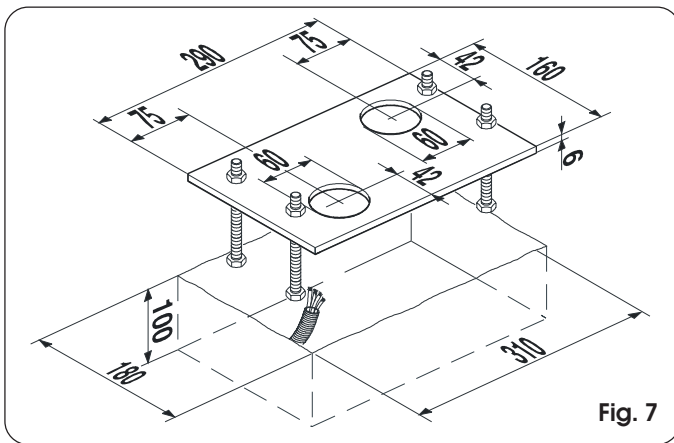

Fig. 7

#### 4.3. MECHANICAL INSTALLATION

- 1) Assemble, on the operator, the securing corners and the anti-vibration spacers as shown in Fig. 8.
- 2) Open the cover, unscrewing the securing screws.
- 3) Fit the operator on the plate, using the supplied washers and nuts as shown in Fig. 9.  
During this operation, route the cables through the raceway on the operator's lower half-body (Fig. 10 ref. A). Take great care in unsheathing all the cables so that the cable gland grips only the individual wires (Fig. 10 ref. B). To access the unit, refer to chapter 5.
- 4) Adjust the height of the feet and the distance from the gate - refer to Fig. 11.
- 5) Secure the gearmotor on the foundation plate, tightening the nuts as shown in Fig. 12.
- 6) Set the operator for manual operation as described in chapter 8.

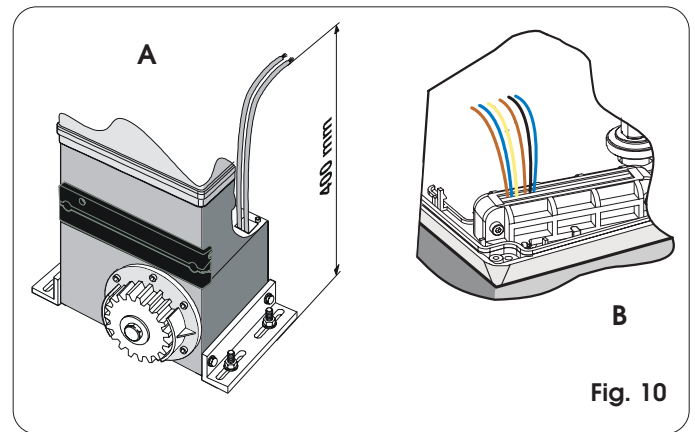

Fig. 10

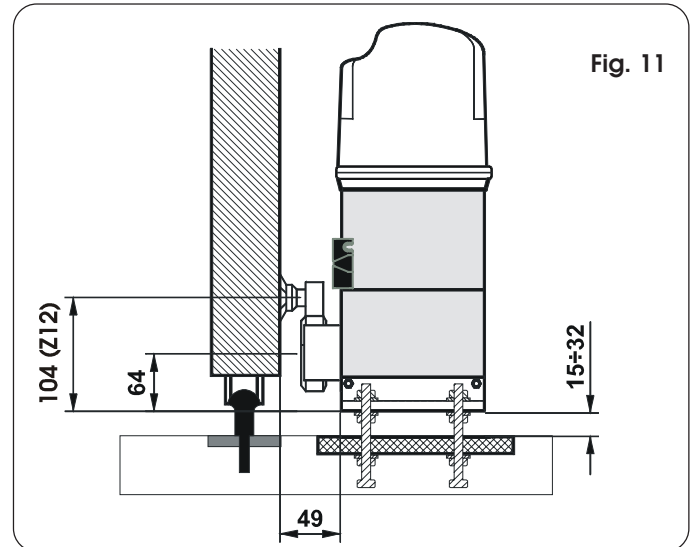

Fig. 11

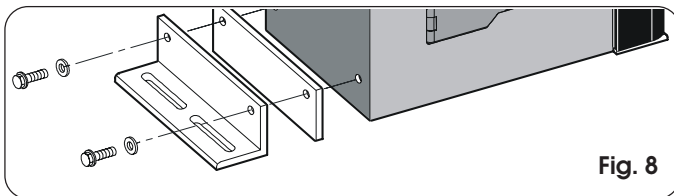

Fig. 8

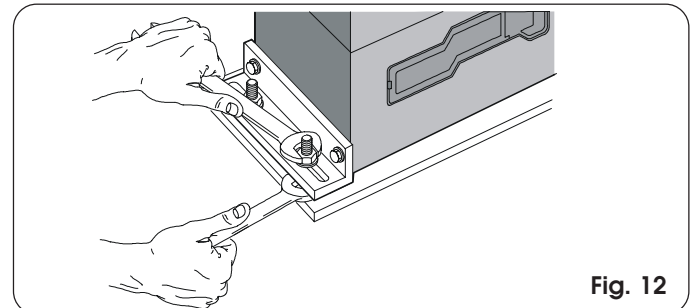

Fig. 12

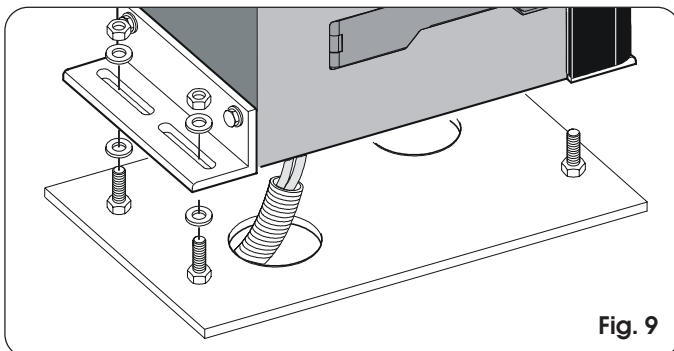

Fig. 9

#### 4.4. INSTALLING THE RACK

##### 4.4.1. STEEL RACK TO BE WELDED (Fig. 13)

- 1) Fit the three threaded pawls on the rack element, positioning them on the upper part of the slot. In this way the play on the slot will enable any adjustments long-term.
- 2) Manually move the leaf to its closed position.
- 3) Lay the first piece of rack level on the pinion and weld the threaded pawl on the gate as shown in Fig. 14.
- 4) Manually move the gate, checking if the rack is resting on the pinion and weld the second and third pawls.
- 5) Fit another rack element next to the previous one, using a piece of rack, as shown in Fig. 15, to synchronise the teeth of the two elements.
- 6) Move the gate manually and weld the three threaded pawls. Carry on like this until you have fully covered the gate.

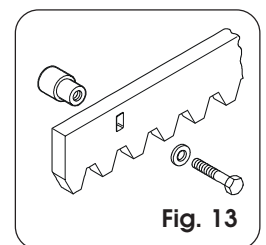

Fig. 13

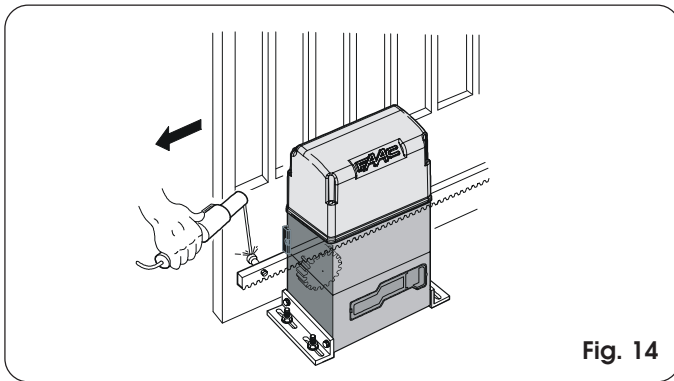

Fig. 14

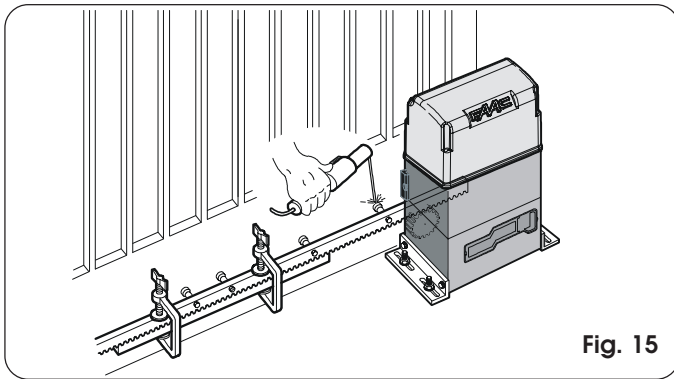

Fig. 15

**4.4.2. STEEL RACK TO BE SCREWED (Fig. 16)**

- 1) Manually move the leaf to its closed position.
- 2) Lay the first piece of rack level on the pinion. Then place the spacer between rack and gate, positioning it on the upper part of the slot.
- 3) Mark the drilling point on the gate. Drill  $\varnothing 6.5$  mm and thread with a  $\varnothing 8$  mm tap. Screw the bolt.
- 4) Manually move the gate, checking if the rack is resting on the pinion and repeat the operations in point 3.
- 5) Fit another rack element next to the previous one, using a piece of rack, as shown in Fig. 16, to synchronise the teeth of the two elements.
- 6) Manually move the gate and perform the securing operations as for the first element, carrying on like this until you have fully covered the gate.

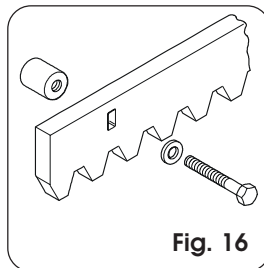

Fig. 16

**Notes on installing the rack**

- Make sure that, during gate travel, all the rack elements do not come out of the pinion.
- Do not, on any account, weld the rack elements either to the spacers or to each other.
- After you have finished installing the rack, to ensure correct meshing with the pinion, we advise you to lower the position of the gearmotor by about 1.5 mm (Fig. 17).
- Manually check if the gate correctly reaches the mechanical travel stops and if there is any friction during travel.
- Do not use grease or other lubricants between rack and pinion.

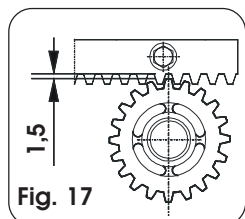

Fig. 17

**4.5. INSTALLING THE ELECTRIC LOCK**

As the gearmotor allows the gate to be moved manually when the motor is not operating, an electric lock must be installed to ensure locking during closure. The lock must be installed vertically on the upper guide upright, if gate height permits, so that release is possible both from inside and outside (fig. 18).

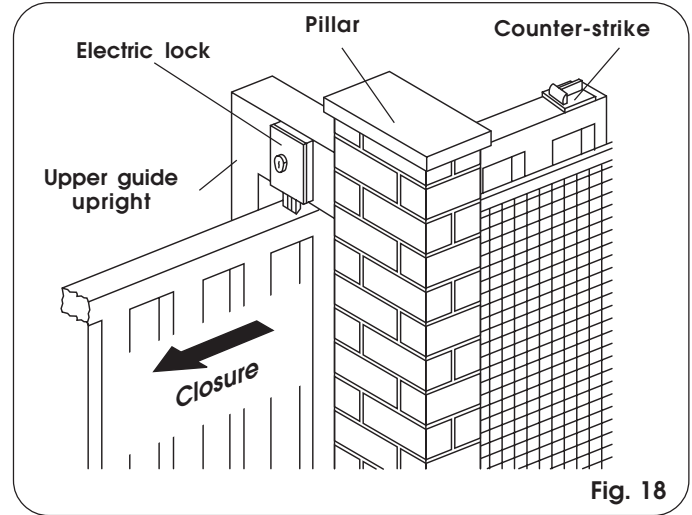

Fig. 18

Install as follows:

- Check if the upper guide upright is of sufficient size for vertically securing the electric lock. If it is not, provide a sturdy support bracket.
  - Make sure that the free space between the lower edge of the guide upright and the upper edge of the gate is sufficient to fit the counter-strike and enable correct operation of the bolt (see fig. 19).
- ➔ **N.B.:** The indicated measurements strictly refer to lock FAAC V75 code 712654 and to counter-strike FAAC code 720329.

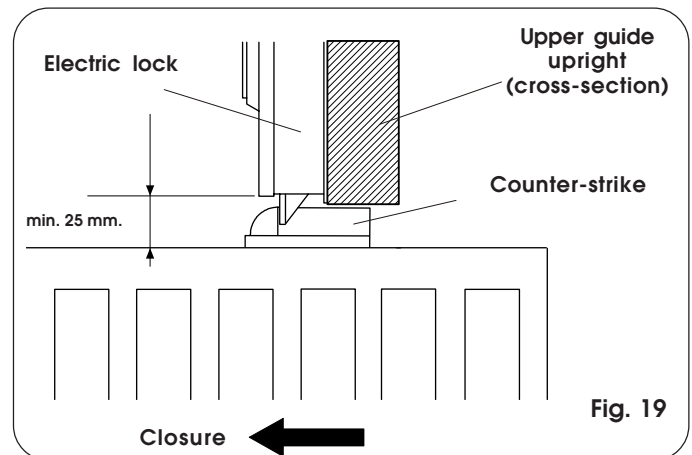

Fig. 19

- Secure the electric lock vertically on the guide upright (or on the support bracket).
- Move the gate to its closing position (at about 2 cm from the mechanical travel stop) and provisionally secure the counter-strike. Secure it definitively only after you have tested the automated system, checked the action of the closing limit switch, and adjusted braking power.

**5. CONNECTIONS FOR THE UNIT**

**5.1. ASSEMBLY OF REMOTE BOARD 578D or 462DF**

If you prefer installing the unit separate from the operator, you may use board 578D or 462DF positioned remotely inside a suitable enclosure. The 844 INTERFACE board (fig.20) is installed on board the operator.

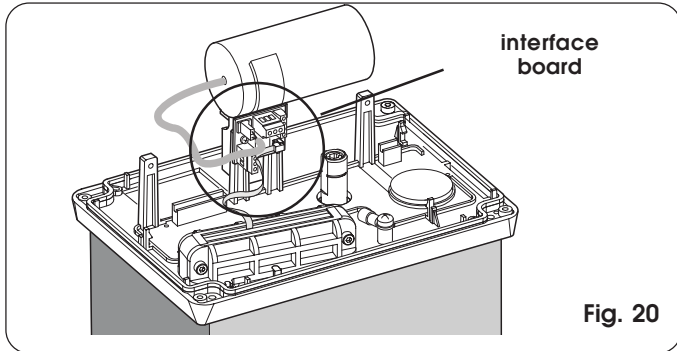

Fig. 20

**5.3. ASSEMBLY OF 462DF BOARD**

If you prefer to install the unit on board the operator, you must use the 462DF board, and the adaptor kit (Fig. 21). To install, consult the specific instructions. The 844 INTERFACE board (fig.20) is installed on board the operator.

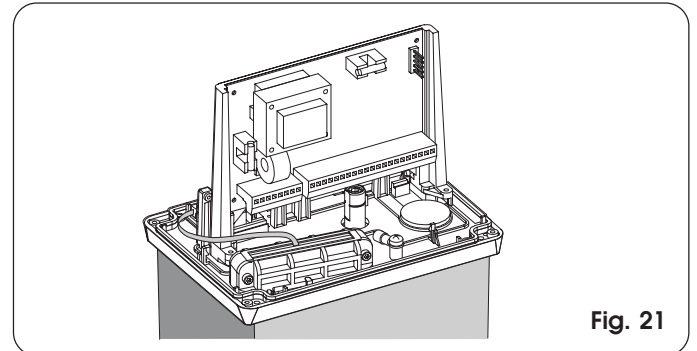

Fig. 21

**5.2. CONNECTIONS FOR UNIT 578D**

To connect the limit switch and the motor, refer to Fig. 22. For the other connections, refer to the instruction for unit 578D.

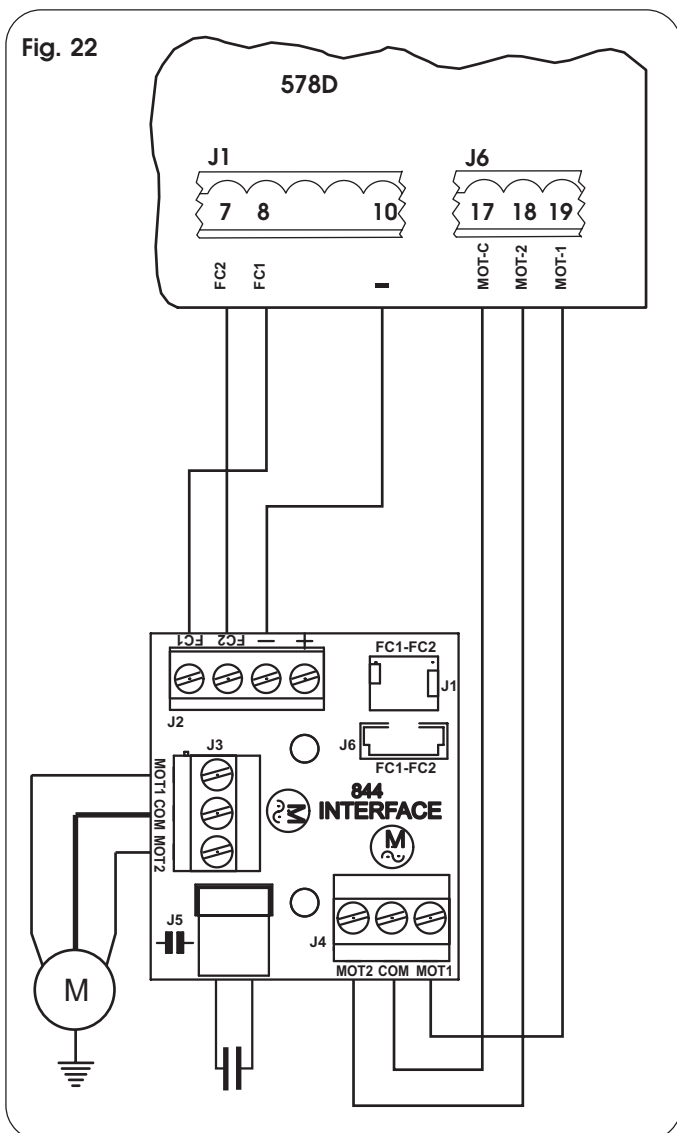

Fig. 22

**5.4. CONNECTIONS FOR UNIT 462DF**

To connect the limit switch and the motor, refer to Fig. 23. For the other connections, refer to the instruction for unit 462DF.

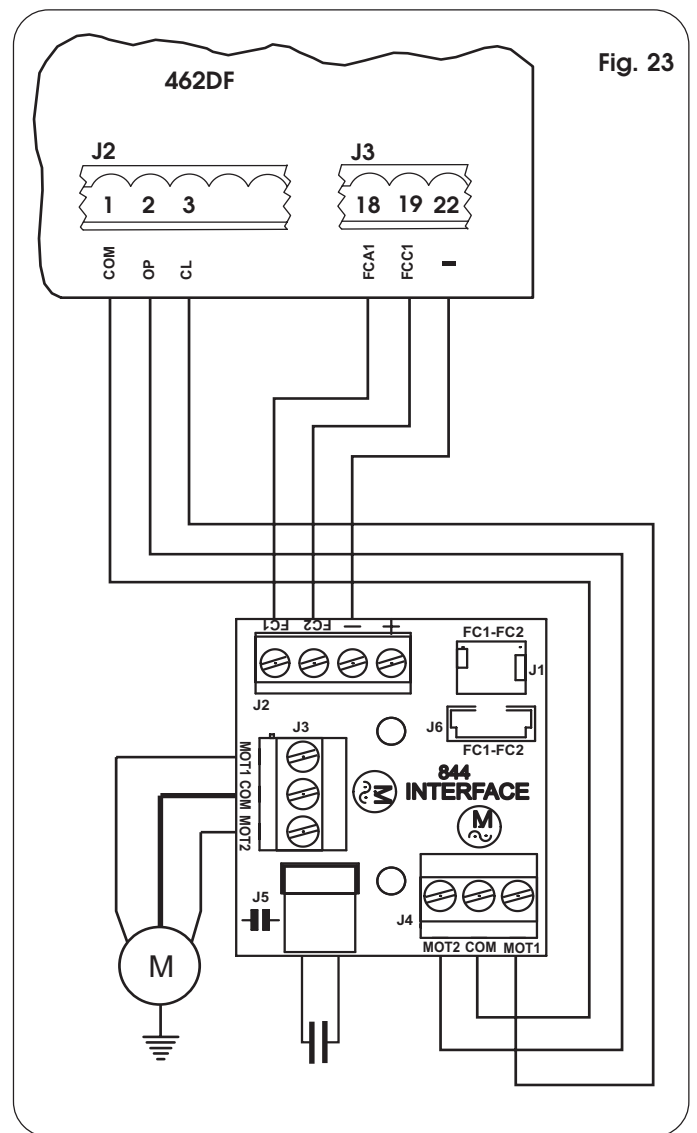
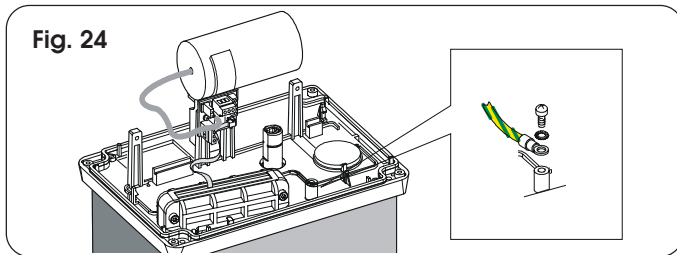

Fig. 23

## 6. START-UP

### 6.1. ELECTRIC CONNECTIONS

Make all the electric connections on the board as shown in chapter 5, including earthing the operator (Fig. 24).



### 6.2. ADJUSTMENT OF MLS LIMIT SENSOR

The 844 operator is equipped with a limit sensor (MLS) which detects the transit of the two magnets fitted on the side of the rack facing the operator (fig. 25).

Procedure for correct positioning of the two supplied magnets:

- 1) Check if the operator is in manual mode (see chapter 8).
- 2) Manually take the gate to opening position, leaving 2 - 5 cm from the mechanical travel stop.
- 3) Fit the magnet (without removing the protective film from the adhesive side) on the face of the rack facing the operator, aligning the upper edges. Slide the magnet on the rack in opening direction until the limit sensor is activated, checking this on the unit. Then take the magnet forward another 45mm.
- 4) Manually take the gate to closing position, leaving 2 - 5 cm from the mechanical travel stop.
- 5) Fit the magnet (without removing the protective film from the adhesive side) on the face of the rack facing the operator, aligning the upper edges. Slide the magnet on the rack in closing direction until the limit sensor is activated, checking this on the unit. Then take the magnet forward about another 45mm.
- 6) Take the gate to its halfway travel point and relock the system (see chapter 9).
- 7) Fix the required deceleration values, consulting the unit's instructions and run the automated system for at least one complete cycle.
- 8) Check if the gate stops at about 2-5 cm from the mechanical travel stop. If necessary, correct the position of the magnets and check if the stop point is correct.
- 9) Mark the position of the magnets on the rack, and remove them.
- 10) Clean the rack on its fitting points, remove the film on the adhesive parts of the magnets (fig.25 ref. 1) and reposition the magnets with the adhesive strip in contact with the rack (fig.25 ref. 2).
- 11) The distance between the limit sensor and the magnets must be from 5 to 12 mm.

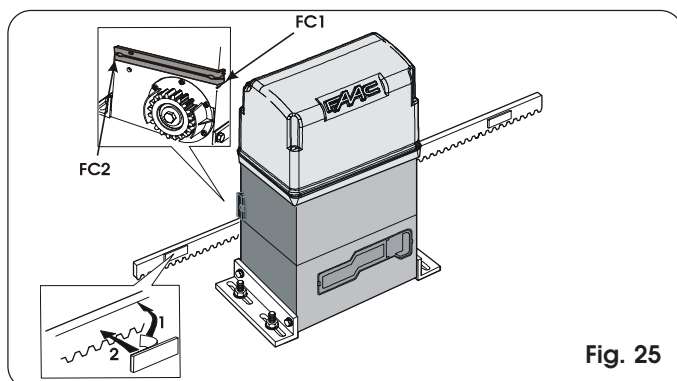

- 12) The magnets must be fitted on the rack but never on the securing screws. If necessary, fit the magnet in contact with the screw and adjust the decelerations to obtain the correct stop point, as shown in the instruction for the unit.

**Attention: due to their powerful magnetic field, the supplied magnets can damage magnetic band components (credit cards, magnetic tapes, floppy disks, etc) and electronic and mechanical equipment (e.g. watches, LCD screens). We advise you not to bring them near to objects that could be damaged if 'immersed' in a magnetic field.**

**6.6. ADJUSTING THE MECHANICAL CLUTCH**

The 844R Rev operator is equipped with a mechanical clutch. Procedure for adjusting the action threshold of the mechanical clutch (we advise you to set it in compliance with current standards):

- 1) **Cut power to the automated system.**
- 2) Keep the motor shaft locked with a wrench, and turn the clutch adjustment screw with an Allen wrench or screwdriver Fig. 26.  
To increase torque, turn the screw clockwise.
- **The operator is supplied with clutch set to maximum value. Therefore, you should initially turn the screw counter-clockwise to reach optimum setting.**  
To reduce torque, turn the screw counter-clockwise.
- 3) Power up the automated system and check if the torque you have just carried out is correctly set.

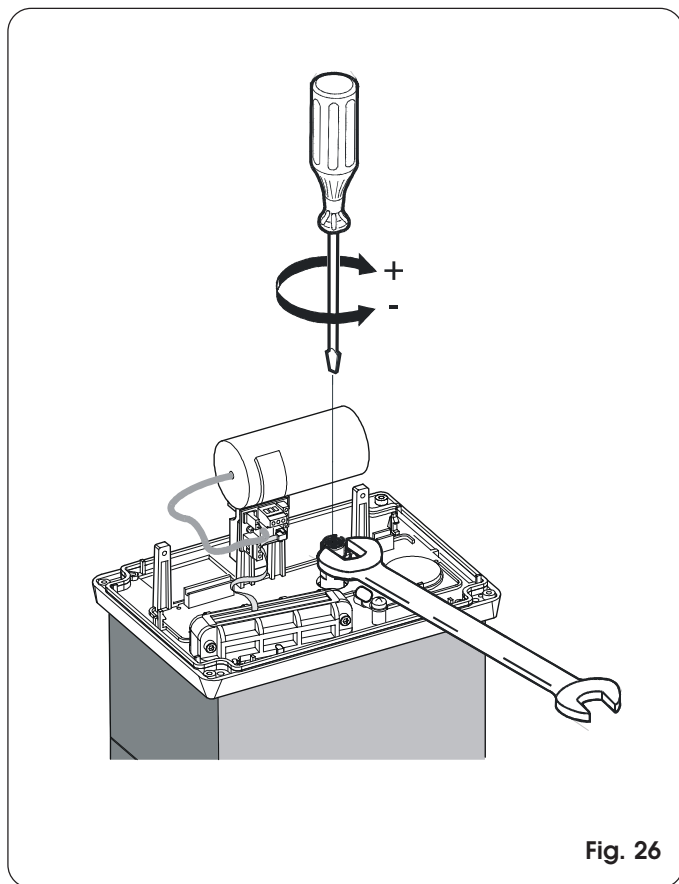

**7. FINAL OPERATIONS**

After completing installation, remove the breather screw (see fig. 27) and apply the danger signal tape on the top of the cover (Fig. 28).

Fit the side panels by pressure, and secure the cover with the supplied screws.

Hand the "User's Guide" to the Client, explain correct operation and use of the gearmotor, and indicate the potentially dangerous areas of the automated system.

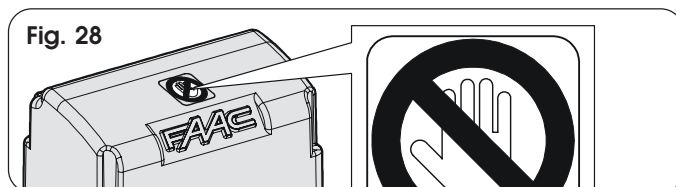
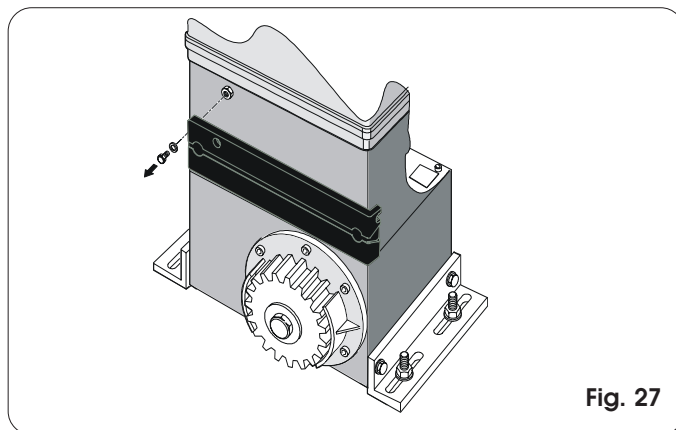

**6.7. CHECK OF STOP POINTS**

Take care over the setting of the post-travel-limit deceleration and braking: if deceleration is too long or braking is insufficient, the marker fitted on the gate's rack (magnet) can overtake the sensor until the latter is disengaged. When the gate stops, make sure that only the limit sensor in question is engaged. If the sensor is engaged and then disengaged, or both the limit sensors are engaged, check the decelerations again as indicated in the instruction of the unit.

**6.8. CHECK OF SAFETY DEVICES AND ACCESSORIES**

Check correct operation of the following: all safety and anti-crushing devices and the accessories used in the system.



## 8. MANUAL OPERATION

If the gate has to be moved manually, due to a power-cut, it is sufficient to push or pull it, because the reversible motor enables the gate to be moved manually.  
Also make sure that the electric lock is not ON.

If the gate has to be moved manually due to a fault or malfunction of the automated system, use the release device as follows:

- 1) Open the electric lock with the key, checking if the gate is free to move.
- 2) Open the protective door and fit the supplied key in the lock (Fig. 29).
- 3) Turn the key clockwise and pull the release lever as shown in Fig. 30.
- 4) Open and close the gate manually.

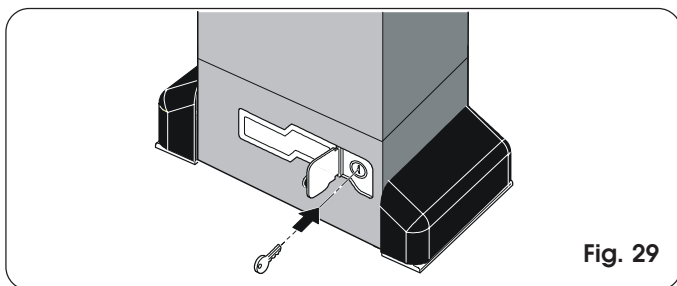

Fig. 29

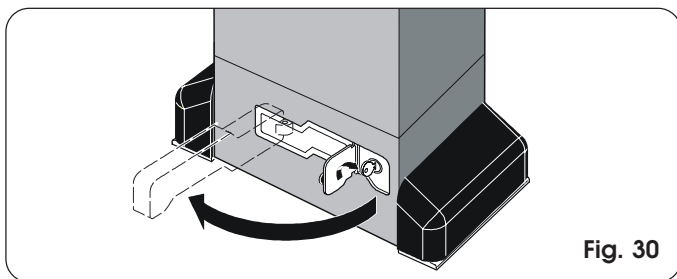

Fig. 30

## 9. RESTORING NORMAL OPERATION MODE

To prevent an involuntary pulse from activating the gate during the manoeuvre, cut power to the system before re-locking the operator.

- 1) Re-close the release lever.
- 2) Turn the key counter-clockwise.
- 3) Remove the key and close the lock protection door.
- 4) Move the gate until the release device meshes.

## 10. ASSEMBLY OF THE CN 60E CONTROL UNIT (OPTIONAL)

The operator is designed to house - with the aid of a DIN bar - the control unit of the CN 60E conductive safety edge. Cut the DIN bar to measure and secure it to the operator with two screws in the two appropriate holes, and hook on the CN 60E control unit (Fig.31).

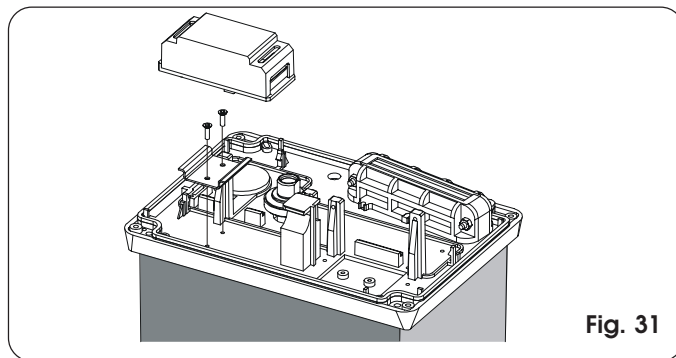

Fig. 31

## 11. SPECIAL APPLICATIONS

There are no special applications.

## 12. MAINTENANCE

Run a functional check of the system at least every 6 months, with special attention to the efficiency of the safety devices (including the thrust force of the operator) and release devices.

### 12.1. TOPPING UP OIL

Periodically check quantity of oil inside the operator. An annual check is sufficient for low to medium use frequency; for heavier duty, check every 6 months.  
To access the tank, temporarily remove the oil filling plug (Fig.32).  
Oil visual check: oil must touch the copper windings of the electric motor.  
To top up, pour in oil up to the level.  
Use only FAAC XD 220 oil.

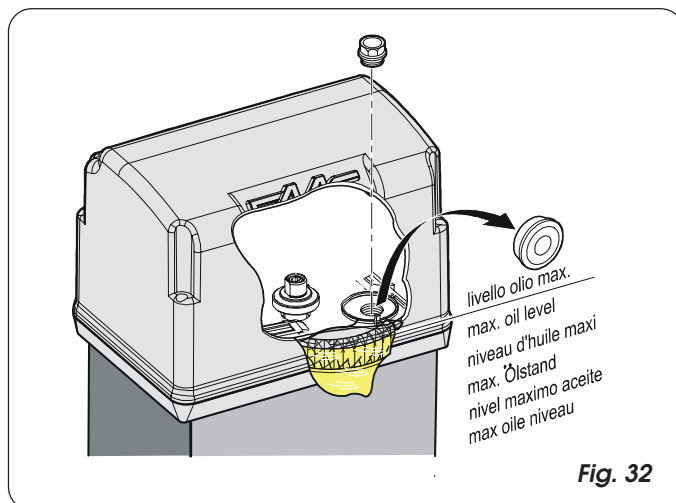

Fig. 32

## 13. REPAIRS

For repairs, contact FAAC authorised Repair Centres.

## USER'S GUIDE

### 844R Reversible AUTOMATED SYSTEM

Read the instructions carefully before using the product and store them for future use.

#### GENERAL SAFETY REGULATIONS

If correctly installed and used, the 844R Reversible automated system will ensure a high degree of safety.

Some simple rules on behaviour can prevent accidental trouble:

- Do not stand near the automated system, and do not allow children, persons or things to do so, especially when it is operating.
- Keep radio-controls, or any other pulse generators that could involuntarily activate the automated system, well away from children.
- Do not allow children to play with the automated system.
- Do not willingly obstruct gate movement.
- Prevent any branches or shrubs from interfering with gate movement.
- Keep warning-lights efficient and easy to see.
- Activate the gate manually only in the event of a power cut.
- In the event of malfunctions, release the gate to allow access and wait for qualified technical personnel to do the necessary work.
- When you have set manual operation mode, cut power to the system before restoring normal operation.
- Do not in any way modify the components of the automated system.
- Do not attempt any kind of repair or direct action whatever and contact qualified FAAC personnel only.
- At least every six months: arrange a check by qualified personnel of the automated system, safety devices and earth connection.

#### DESCRIPTION

The 844R Reversible automated system is ideal for controlling vehicle access areas of medium transit frequency.

The 844 R Reversible automated system for sliding gates is an electro-mechanical operator which transmits movement to the sliding gate via a rack and pinion appropriately coupled to the leaf.

The operation of the sliding gate is controlled by an electronic control unit which can be built-in on board (462DF) or connected in a remote position (578D or 462DF).

When, with the gate closed, the unit receives an opening command by a radio-control or from another suitable device, it activates the motor until the opening position is reached.

If automatic operating mode was set, the gate re-closes automatically after the selected pause time has elapsed.

If the semi-automatic mode was set, a second pulse must be sent for re-closing.

An opening pulse during re-closing, always causes movement to be reversed.

A stop pulse (if supplied) always stops movement.

For details on sliding gate behaviour in different function logics, consult the installation technician.

The automated systems include accessories and safety devices (photocells, edges) that prevent the gate from closing when there is an obstacle in the area they protect.

Manual opening is always possible, except in case of a fault. In this case, the release system must be remedied.

The gearmotor has an adjustable mechanical clutch which, when coupled to an electronic device, provides the necessary anti-crushing safety, guaranteeing motion reversing for 2 sec. both during closing and opening.

A magnetic sensor detects transit of the markers on the rack, which correspond to the travel limit positions.

The warning-light indicates that the gate is currently moving. A handy manual release facility makes it possible to move the gate in the event of a fault.

#### MANUAL OPERATION

If the gate has to be moved manually, due to a power-cut, it is sufficient to push or pull it, because the reversible motor enables the gate to be moved manually.

If the gate has to be moved manually due to a fault in the automated system, use the release device as follows:

- 1) Open the electric lock with the key, checking if the gate is free to move.
- 2) Open the protective door and fit the supplied key in the lock as shown in Fig. 1.
- 3) Turn the key clockwise and pull the release lever as shown in Fig. 2.
- 4) Open and close the gate manually.

#### RESTORING NORMAL OPERATION MODE

To prevent an involuntary pulse from activating the gate during the manoeuvre, cut power to the system before re-locking the operator.

- 1) Re-close the release lever.
- 2) Turn the key counter-clockwise.
- 3) Remove the key and close the lock protection door.
- 4) Move the gate until the release device meshes.

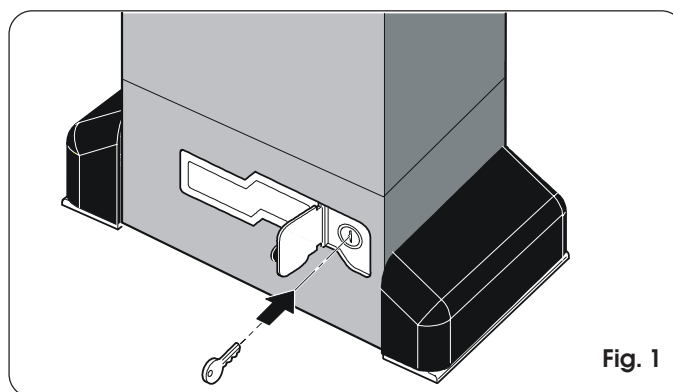

Fig. 1

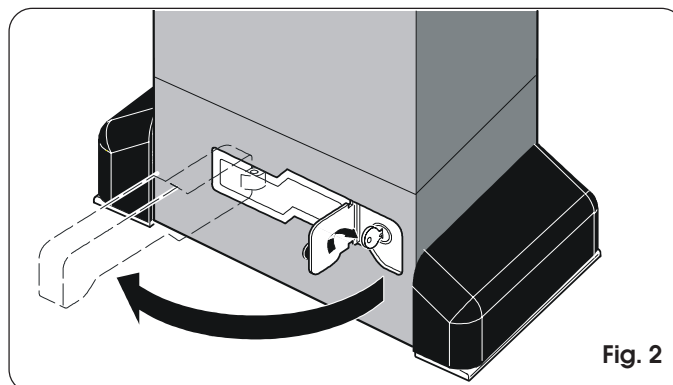

Fig. 2