

CE DECLARATION OF MACHINE CONFORMITY

(DIRECTIVE 89/392/EEC, ANNEX II, PART B)

Manufacturer : FAAC S.p.A.

Address: Via Benini, 1 - 40069 Zola Predosa BOLOGNA - ITALY

Declares that: Operator mod. 390,

- is manufactured to be incorporated in a machine or for assembly with other machines to constitute a machine under the provisions of Directive 89/392/EEC, and subsequent amendments 91/368/EEC, 93/44/EEC, 93/68/EEC;
- conforms to the essential safety requirements of the following further EEC Directives:

73/23/EEC and subsequent amendment 93/68/EEC.
89/336/EEC and subsequent amendment 92/31/EEC and 93/68/EEC

and, furthermore, declares that putting the machine into service is forbidden until the machine in which it will be incorporated or of which it will become a part has been identified and it has been declared as conforming to the conditions of Directive 89/392/EEC and subsequent amendments, merged into national law by DPR n° 459 of 24 July 1996.

Bologna, 01 January 1999

The Managing Director
A. Bassi



WARNING FOR THE INSTALLER

GENERAL SAFETY OBLIGATIONS

- CAUTION! It is important for personal safety to follow all the instructions carefully. Incorrect installation or misuse of the product may cause people serious harm.**
- Read the instructions carefully before starting to install the product.
- Packaging material (plastic, polystyrene, etc.) must not be left within reach of children as it is a potential source of danger.
- Keep the instructions in a safe place for future reference.
- This product was designed and manufactured strictly for the use indicated in this documentation. Any other not expressly indicated use may damage the product and/or be a source of danger.
- FAAC accepts no responsibility due to improper use of the automation or use other than that intended.
- Do not install the appliance in an area subject to explosion hazard: inflammable gasses or fumes are a serious safety hazard.
- Mechanical construction elements must meet the provisions of UNI8612, CEN pr EN 12604 and CEN pr EN 12605 standards.
To obtain an adequate level of safety in non EU countries, the above mentioned standards must be observed in addition to national standards.
- FAAC will not accept responsibility if the principles of good workmanship are disregarded in constructing the closing elements to be motorised, and if any deformation occurs during use of the said elements.
- Installation must meet the following standards: UNI8612, CEN pr EN 12453 and CEN pr EN 12635.
The safety class for the automation must be C+D.
- Before carrying out any work on the system, switch off the electricity supply.
- The mains electricity supply of the automation must be fitted with a single-pole switch with contact opening distance of 3mm or greater. Use of a 6A thermal breaker with single-pole circuit break is recommended.
- Make sure there is a differential switch with 0.03A threshold upstream of the system.
- Check that the earthing system is correctly made and connect the closure metal parts to it. Also connect the Yellow/Green wire of the automation to the earthing system.
- The automation includes an intrinsic anti-crushing device consisting of a torque control which, however, must be installed together with other safety devices.
- The safety devices [e.g.: photocells, sensitive edges, etc...] protect any dangerous areas against **Movement mechanical risks**, such as, crushing, dragging, or shearing.
- Use of at least one indicator-light is essential for each system (e.g.: FAAC LAMP MINILAMP, etc.) as well as a sign adequately fixed to the frame structure, in addition to the devices mentioned at point "16".
- FAAC accepts no responsibility regarding safety and correct operation of the automation, should components made by manufacturers other than FAAC be used in the system.
- Use only FAAC original spare parts for maintenance.
- Do not make any alterations to the components of the automation.
- The installer must supply full information regarding manual operation of the system in the event of an emergency and provide the user of the system with the "User's Guide" included with the product.
- Do not allow children or other persons to stand near the product while in operation.
- Keep remote controls or any other pulse generator well away from children, to prevent the automation from being activated accidentally.
- The user must refrain from attempting to repair or adjust the system personally and should contact qualified personnel only.
- Anything not expressly provided for in these instructions is not permitted.**

AUTOMATION 390

These instructions apply to the following model:

FAAC 390

The 390 external automation with articulated arms automates residential swing-leaf gates with leaves of up to 3m in length, and is ideal for applications on large pilasters without the need to provide niches (sometimes required to observe the installation dimensions of piston driven devices).

It consists of an irreversible electro-mechanical operator with guard and an articulated-arm activation system to be fitted to the gate with the appropriate accessories.

The irreversible system ensures the gate is mechanical locked when the motor is not operating. No lock need be installed for leaves up to 1.8 m in length.

A manual release makes it possible to move the gate in the event of a power-cut or fault.

➔ To obtain anti-crushing protection, you have to use electronic appliances with a torque control electronic device.

The 390 automation was designed and manufactured to control access of vehicles. Avoid any other use whatever.

1. DESCRIPTION AND TECHNICAL SPECIFICATIONS

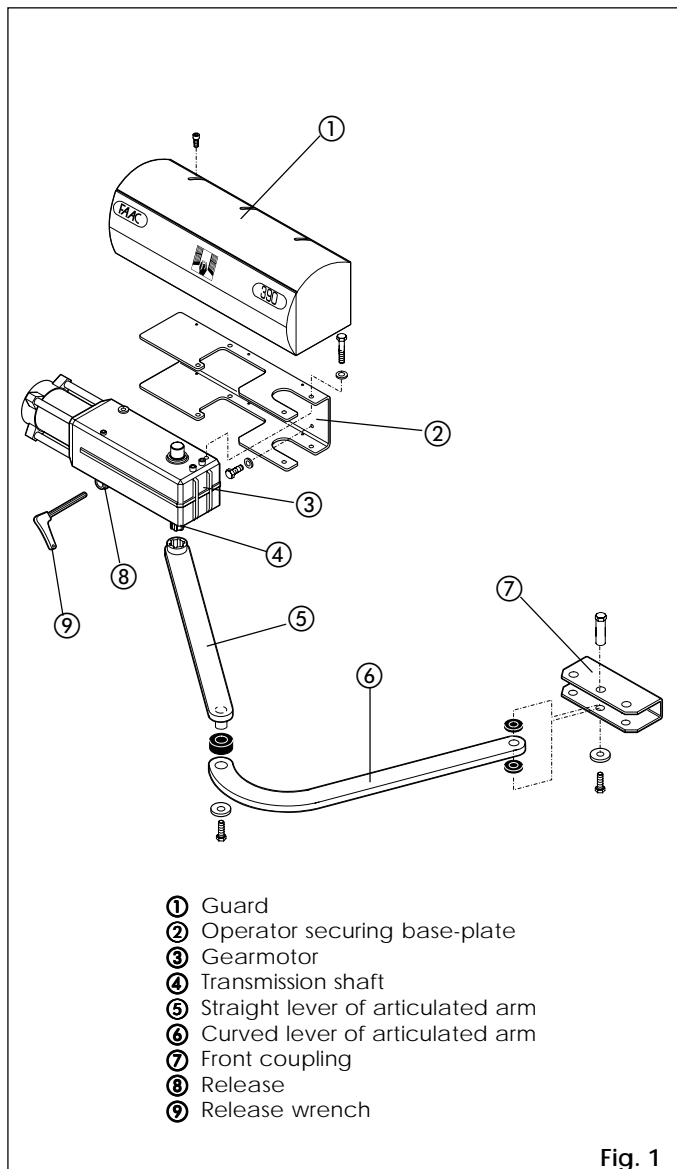

TAB. 1 TECHNICAL SPECIFICATION OF OPERATOR 390

MODEL	390
Power supply	230V~ (+ 6 % - 10 %) 50Hz
Power absorption (W)	280
Max torque (Nm)	250
Angular velocity (°/sec)	9
Use frequency (cycles/hour)	15
Ambient temperature	-20 ÷ +55 °C
Weight of gearmotor (Kg)	11.5
Protection class	IP 31
Leaf max length (m)	1.8 (without electric lock) 3 (with electric lock)
Gearmotor overall dimensions LxHxD (mm)	see fig. 2
Technical specifications of electric motor	
RPM	960
Reduction ratio	1 : 640
Thermal protection for winding	140°C
Power (W)	280
Current absorption(A)	1.5
Starting capacitor	8µF
Power supply	230V~ (+ 6 % - 10 %) 50Hz

2. DIMENSIONS

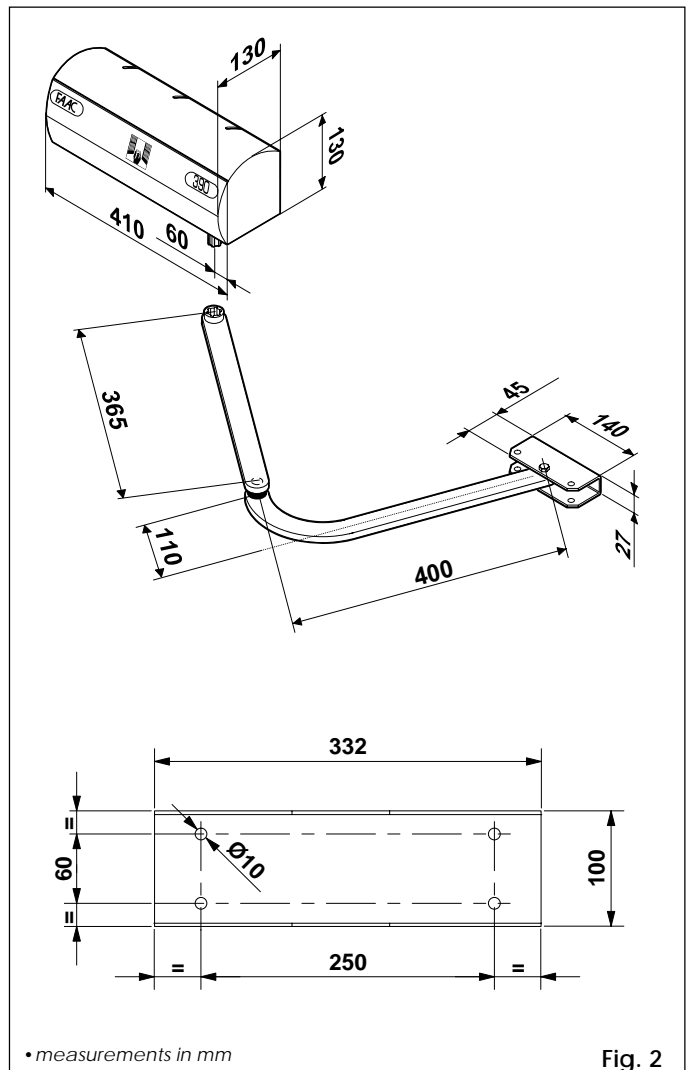

3. ELECTRICAL EQUIPMENT (standards system)

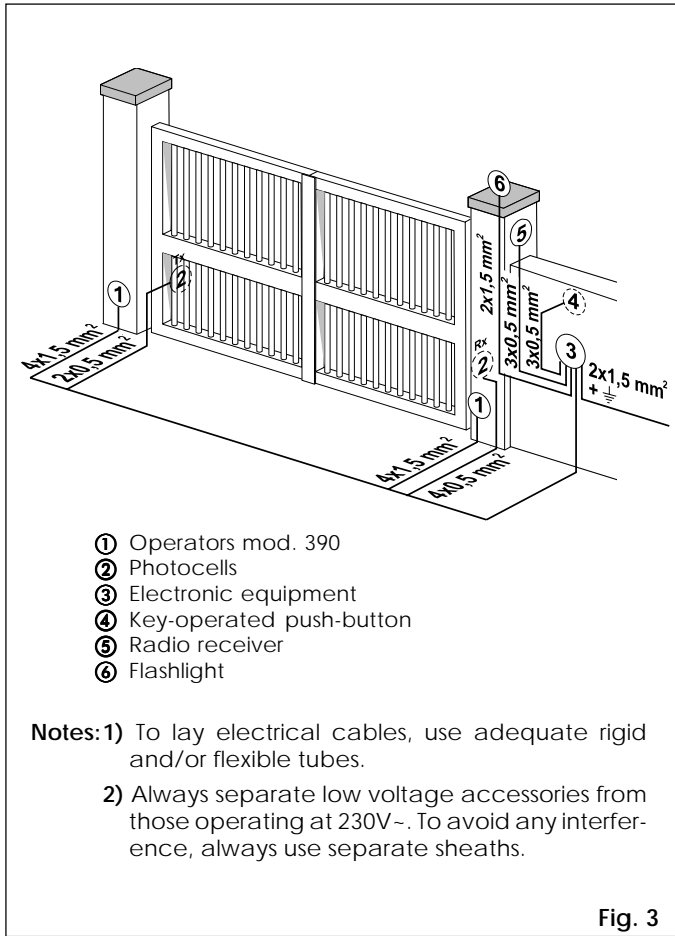

4. INSTALLATION OF AUTOMATION

4.1. PRELIMINARY CHECKS

To ensure safety and an efficient automation, make sure the following requirements are met:

- The gate structure must be suitable for automation. In particular, make sure it is sufficiently sturdy and rigid, and that its dimensions are in line with those indicated in the technical specifications.
 - Make sure that the leaves move properly and uniformly, without any irregular friction during their entire travel.
 - Check if hinges are in good condition.
 - Make sure the travel limit mechanical stops are present.
- We advise you to carry out any metalwork jobs before installing the automation.

4.2. INSTALLATION DIMENSIONS

Establish the installation position of the operator by consulting Fig. 4-5-6.

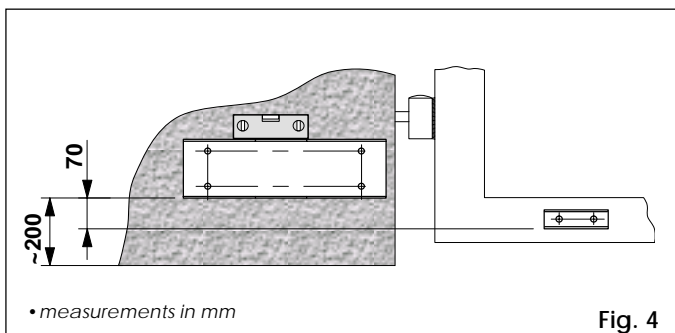

4.2.1. RECOMMENDED DIMENSIONS FOR INWARD OPENING

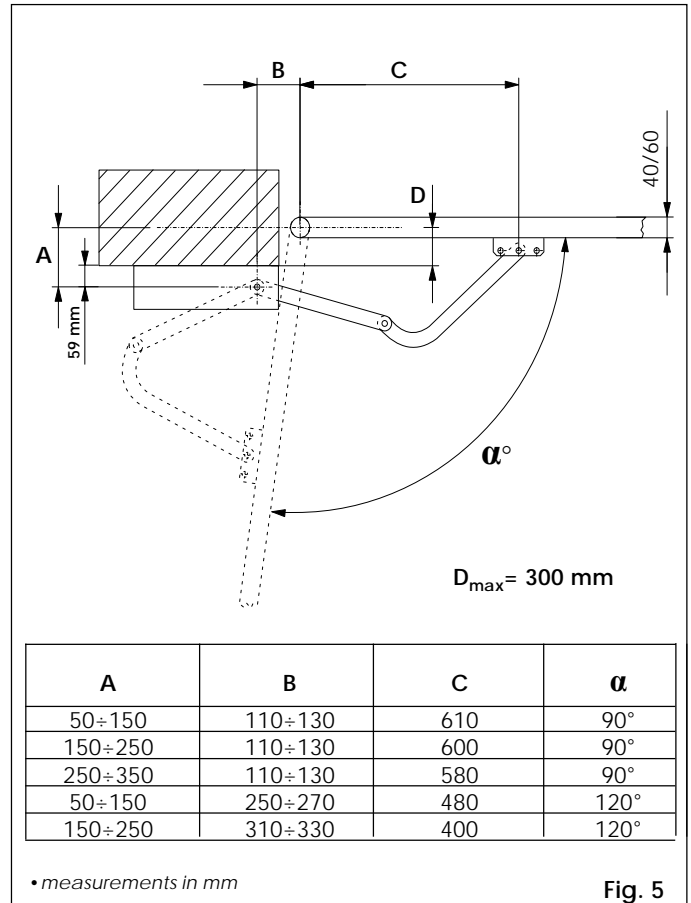

4.2.2. RECOMMENDED DIMENSIONS FOR OUTWARD OPENING

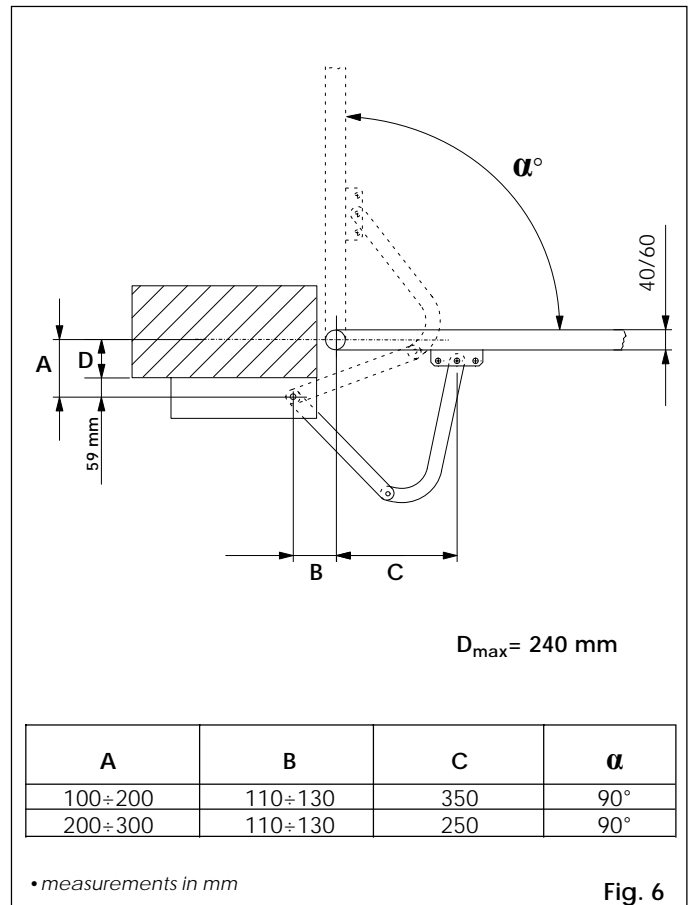

4.3. INSTALLATION STEPS

The 390 operator, base-plate and articulated arm are designed either for right-hand (Fig. 7-Rh) or left-hand (Fig. 7-Lh) installation.

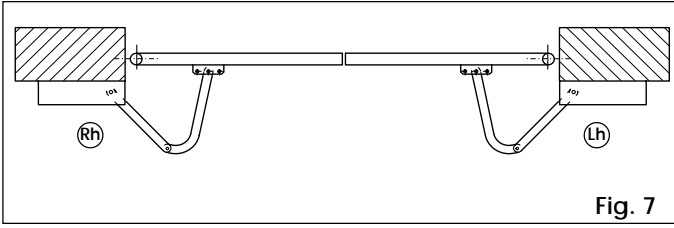

Fig. 7

- Secure the base-plate to the pilaster, using Ø10 screws and suitable expansion plugs (Fig. 8), and check it is perfectly horizontal.
- Fit the gearmotor unit on the base-plate and secure it with the two screws, nuts and flexible washers (Fig.8).
 - ➔ The transmission shaft must always face downward.

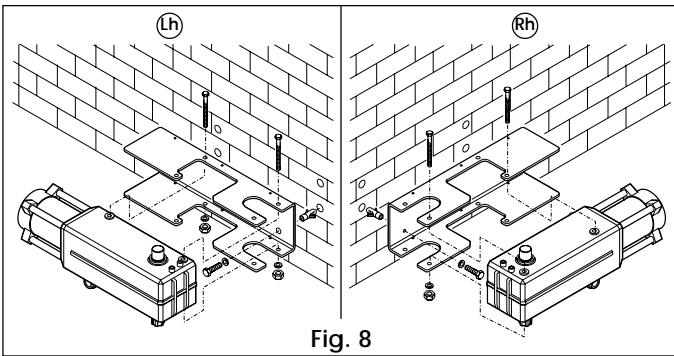

Fig. 8

- Assemble the articulated arm and front coupling as shown in Fig. 9.

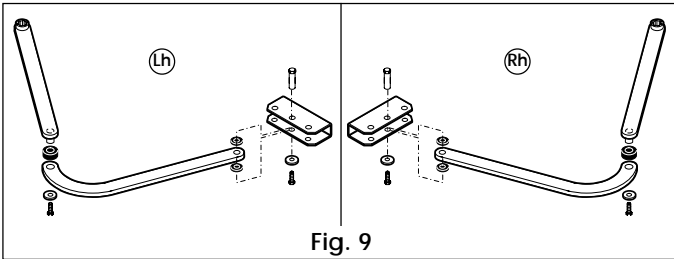

Fig. 9

- Fit the straight lever of the articulated arm on the gearmotor shaft and tighten it with the supplied screw and washer (Fig. 10).
- Release the operator (chapter 5.)
- Establish the securing position of the front coupling on the leaf, observing dimension "C" defined previously (chapter 4.2). Check that arm and coupling are perfectly horizontal.
- The coupling may be welded directly onto the leaf (Fig. 11) or screwed by using the threaded inserts (Fig. 12).

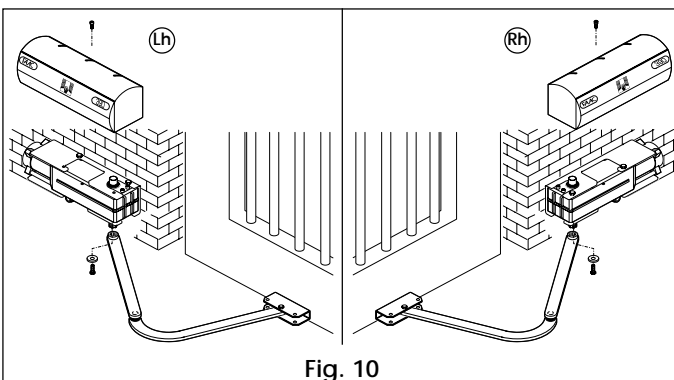

Fig. 10

In both cases, provisionally remove the coupling from the arm in order to secure it.

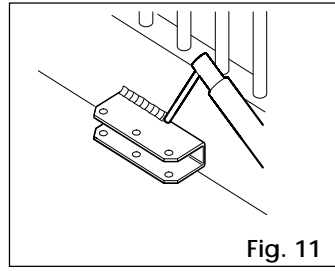

Fig. 11

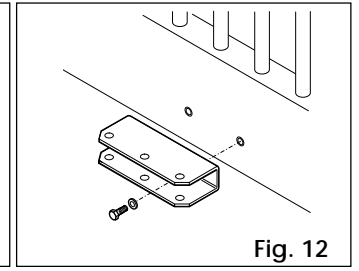

Fig. 12

- Fit the guards on the operator (Fig. 10).
- Re-lock the operator (chapter 6.)
Make the electrical connections of the selected electronic appliance, observing the annexed instructions.

4.4. TEST OF THE AUTOMATION

When you have finished installation, carefully check the operating efficiency of the automation and of all accessories connected to it, safety devices in particular. Hand the "User's Guide" page to the Client, and describe how the operator should function and be used correctly, stressing the potentially dangerous areas of the automation.

5. MANUAL OPERATING MODE

If the gate has to be operated manually in the event of a power-cut or fault to the automation, use the release device as follows:

- Fit the supplied Allen wrench and turn it by about a half turn until it stops, in the direction shown in Fig. 13, depending on type of installation.

6. RESTORING NORMAL OPERATING MODE

To avoid an involuntary pulse from activating the gate during the manoeuvre, before re-locking the operator, switch off power to the system.

- Fit the supplied Allen wrench and turn it by about a half turn until it stops, in the direction shown in Fig. 13, depending on type of installation.

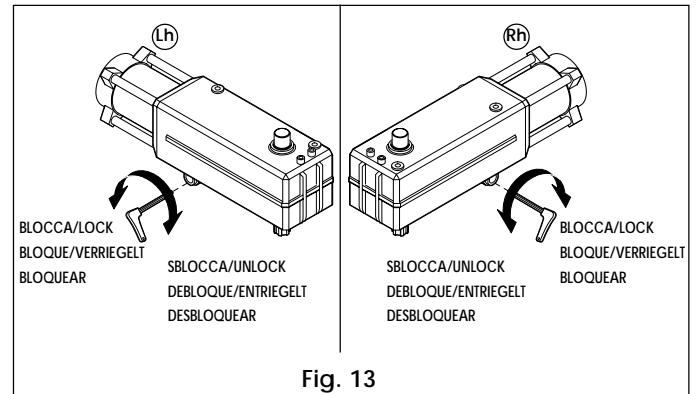

Fig. 13

7. MAINTENANCE

Do the following jobs at least every six months:

- Check if motor torque is correctly set.
- Check efficiency of the release system.
- Check efficiency of safety devices.

8. REPAIRS

For any repairs, contact our authorised Repair Centres.

User's guide

AUTOMATION 390

Read the instructions carefully before using the product, and keep them for future consultation.

GENERAL SAFETY REGULATIONS

If installed and used correctly, the 390 automation will ensure a high degree of safety. Some simple rules regarding behaviour will avoid any accidental trouble:

- Do not pass through the leaves while they are moving. Before passing through the leaves, wait until they are fully open.
- Do not, on any account, stand between the leaves.
- Do not stand near the automation and do not allow children and other people to stand there, especially while it is operating.
- Keep remote controls or any other pulse generator well away from children to prevent the automation from being activated involuntarily.
- Do not allow children to play with the automation.
- Do not willingly obstruct movement of the leaves.
- Do not allow branches or shrubs to interfere with leaf movement.
- Keep illuminated signalling systems efficient and clearly visible.
- Do not attempt to activate the leaves manually unless you have released them first of all.
- In the event of a malfunction, release the leaves to allow access and wait for qualified personnel to take appropriate action.
- After enabling manual operating mode, switch off the power supply to the system before restoring normal operating mode.
- Do not make any alterations to the components of the automation.
- Do not attempt to repair or adjust the system personally, but contact qualified personnel only.
- Call in qualified personnel at least every 6 months to check the efficiency of the automation, safety devices and earth connection.

DESCRIPTION

These instructions apply to the following model:

FAAC 390

FAAC 390 automation for residential swing-leaf gates consists of an irreversible electro-mechanical operator with guard and an articulated-arm activation system fitted to the gate with the appropriate accessories.

The irreversible system ensures the gate is mechanically locked when the motor is not operating. No lock need be installed for leaves up to 1.8 m in length.

A manual release makes it possible to move the gate in the event of a power-cut or fault.

The operators are supervised by an electronic control unit, housed in a container adequately protected against atmospheric agents.

The leaves are normally in closed position.

When the electronic control unit receives an opening command by remote control or by any other pulse generator, it activates the operator to rotate the leaves until they are sufficiently open to provide access.

If automatic operating mode was set, the leaves close on their own after the selected pause time has elapsed.

If semi-automatic operating mode was set, a second pulse must be sent to allow the leaves to close again.

A stop pulse (if supplied) always stops movement.

For detail on operation of the automation under different

operational logics, consult the installation technician.

The automations include safety devices (photocells, sensitive edges,...) which prevent the leaves from moving when there is an obstacle in the area they protect.

The 390 automation requires use of electronic appliances with an electronic torque control device.

The light indicates that leaves are moving.

MANUAL OPERATING MODE

If the gate has to be operated manually in the event of a power-cut or automation fault, use the release device as follows:

- Fit the supplied Allen wrench and turn it by about a half turn until it stops, in the direction shown in Fig. 1-2, depending on type of installation.

RESTORING NORMAL OPERATING MODE

To avoid an involuntary pulse from activating the gate during the manoeuvre, before re-locking the operator, switch off power to the system.

- Fit the supplied Allen wrench in the release device and turn it by about a half turn until it stops, in the direction shown in Fig. 1-2, depending on type of installation.

- ➔ The release device can be activated without removing the guard.

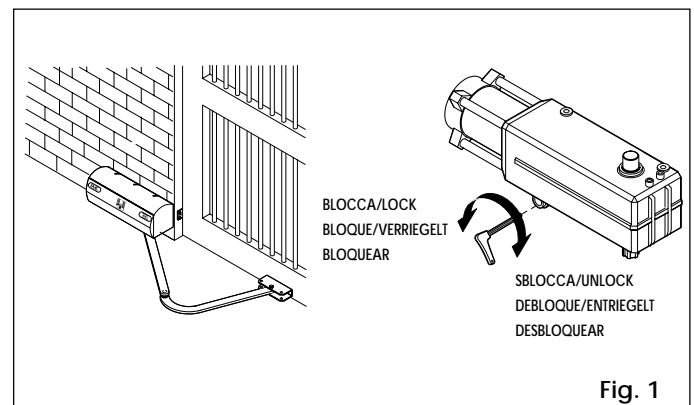

Fig. 1

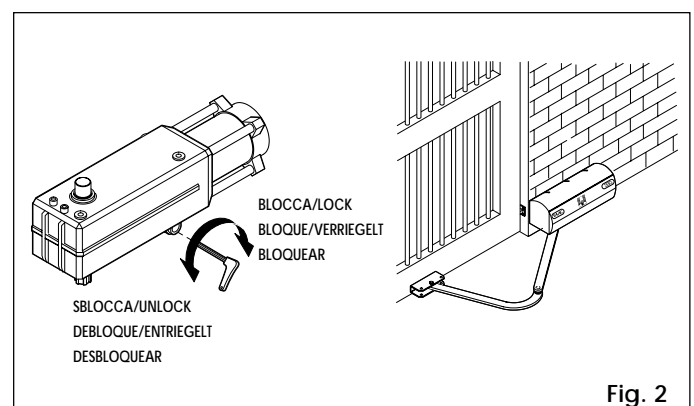

Fig. 2