



EXWBJ



EXHC + EXHS

EXHD + EXHS

- Explosion-proof certified
- Indoor and outdoor installations
- Built in baked-on enamelled non-corrosive aluminium (anticorodal)
- Wide range of accessories
- Weatherproof standard IP65

The explosion-proof products are made of a strong non-corrosive aluminium alloy (anticorodal), with a thickness ranging from 10 mm up to 12 mm. They are baked-on enamel with a RAL7032 colour and weatherproof with an IP65 protection.

EXHC

The cylindrical body of EXH housing (diameter 210 mm and length 400 mm) is closed on the opposite sides by two 12 mm thick flanges. The housing is equipped with two 3/4" gas cable glands that allow the wiring. The camera housing is equipped with an internal housing heater and optional sunshield. The EXHC housing is manufactured according to II 2 G EEx d IIC T6 and is ATEX certified, for installation in potentially explosive areas.

EXHD

Explosion-proof housing with the same specifications as the EXH series but fitted with a patented device for the protection of the glass which gives clear vision in dirty environments. It consists of a connection flange with the housing, a closing flange and an explosion-proof central body containing a rugged transparent

glass, a direct current motor power supplied at 24 Vdc, two windings and a transparent Mylar film, installed just in front of the glass. The motor drives, through four pinions with gear rim, the winding for recovering the dirty Mylar film, while at the same time the other winding installed on the opposite side releases the clean film. The motor is remotely controlled through a two wire on-off contact (common and + 24Vdc). NOTE: the control unit of the glass protection device is not supplied with the unit!

The transparent Mylar film, 80 mm wide and 18 m long, allows 350 shifting steps. When the film is dirty, the operator will activate the motor shifting the film to obtain a clean camera picture (the step for allowing the complete shift of the dirty film is about 50 cm). The end of the Mylar film will be indicated to the operator through marks printed on the last 50 cm of the film.

EXWBJ

Bracket and swivel for EXH series in non-corrosive aluminium alloy (anticorodal). They allow the EXH housing to be firmly attached to the wall. Only the EXBJ allows the column mount.

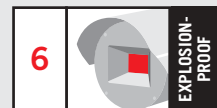

MODELS

	Certification IIB+H2	Certification IIC	Heater	Reinforced heater	Glass protection device
EXHC000	•	•	•		
EXHC003R*	•	•		•	
EXHD001	•		•		•

* Under certification.



EXHC

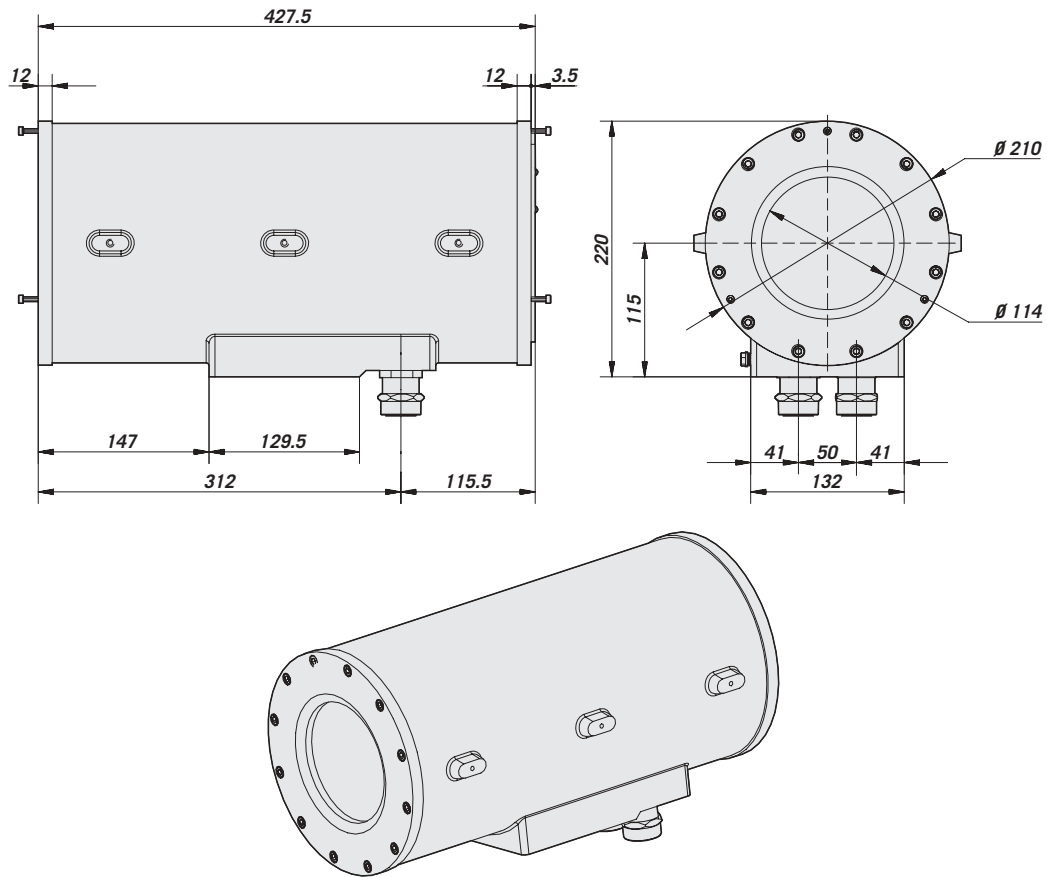

EXBJ

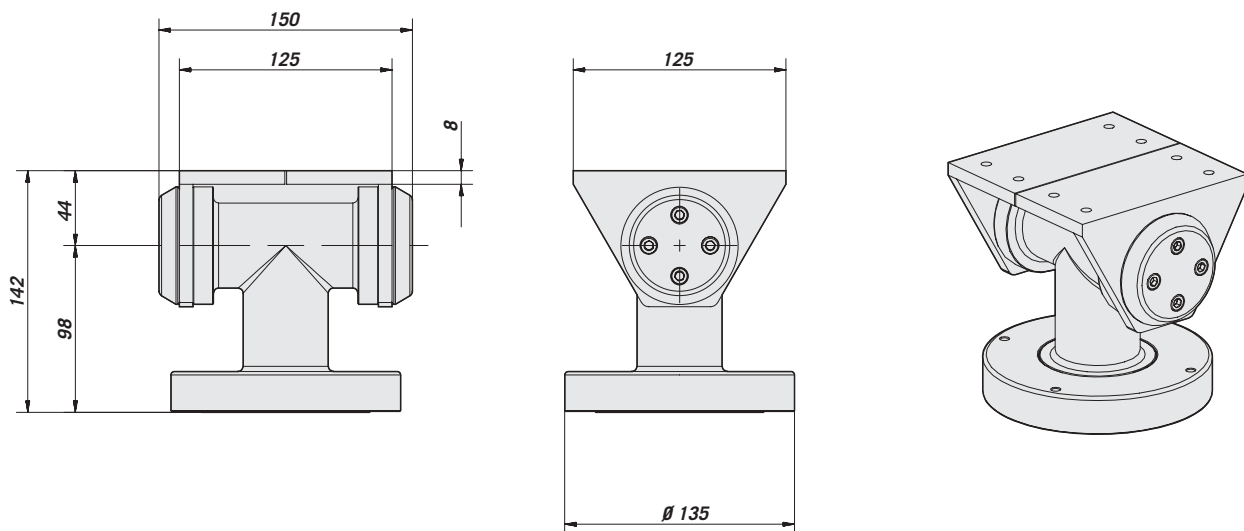

The values are in millimeters.

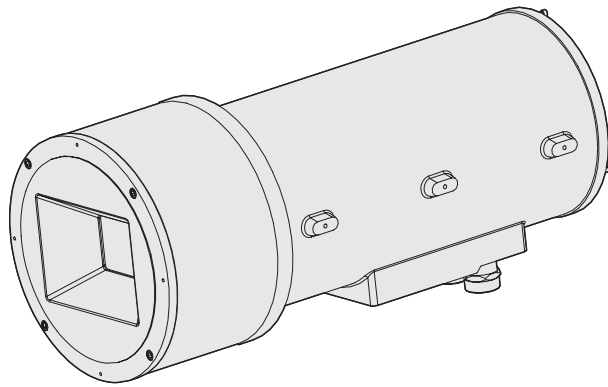
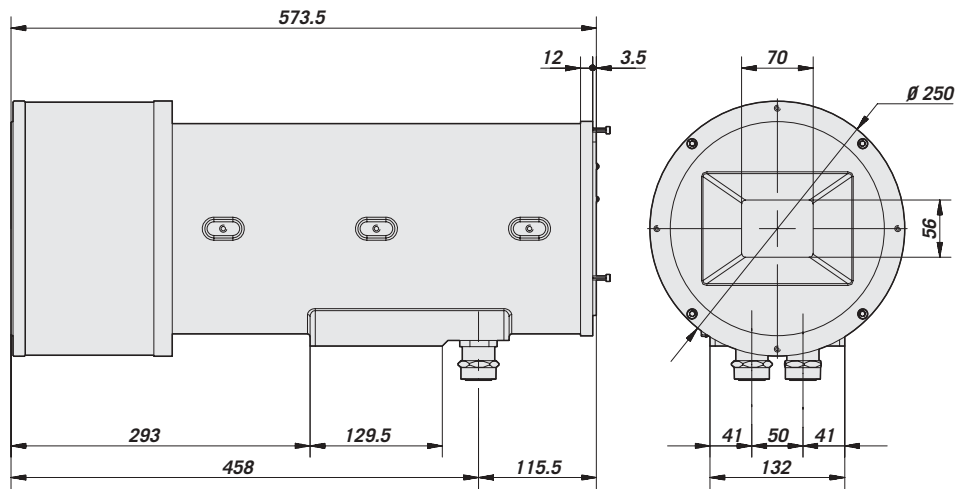
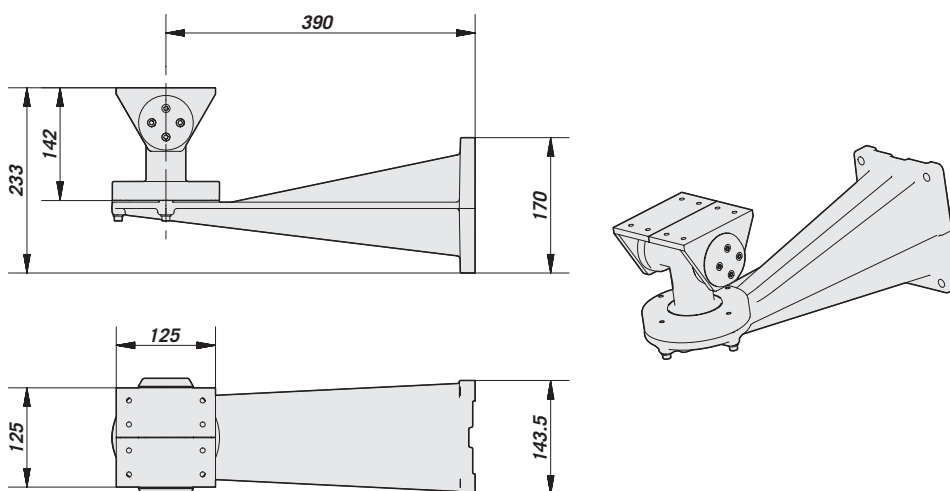
EXHD

EXWBJ

The values are in millimeters.



TECHNICAL DATA

GENERAL

EXHC - EXHD

- Made of non-corrosive aluminium cast (anticorrosive)
- Epoxy polyester powder painted RAL7032 colour
- Painted with plast-coat for low temperature, blue color (mod. EXHC003R, under certification)
- Supplied with: instruction manual and conformity declaration

EXWBJ

- Made of strong non-corrosive aluminium alloy (anticorrosive)
- Epoxy polyester powder painted RAL7032 colour
- Only joint EXBJ allows parapet mounting

MECHANICAL

- 2x3/4" Gas cable glands

External dimensions (ØxL):

EXHC	Ø 210x430 mm (8.2x16.9 in)
EXHD	Ø 250x575 mm (9.8x 22.6 in)

Internal dimensions (DiameterxL):

EXHC	Ø 180x380 mm (7x14.9 in)
EXHD	Ø 180x460 mm (7x 18.1 in)

Internal usable area (BxHxL):

EXHC	100x100x280 mm (3.9x3.9x11 in)
EXHD	100x100x360 mm (3.9x3.9x14.1 in)

Window (BxH):

EXHC	Ø 114 mm (4.48 in)
EXHD	70x53 mm (2.7x2 in)

EXHD

- Mylar film 80 mm (3.1 in) wide and 18 m (59 ft) length, 350 shifting steps, marks printed on the last 50 cm (19 in)

EXWBJ

- Wall mount
- Payload: 35 kg (77 lb)
- Length: 455 mm (17.9 in)

EXBJ

- Parapet mount

ELECTRICAL

- Heater 24VAC 20W: Ton 10°C +/- 4°C (50°F) Toff 25 °C +/- 3°C (77°F)
- Glass protection device 24VDC, 2W (EXHD)

INSTALLABLE DEVICES

- Camera equipped with lens for a maximum power of max 20 W, input power supply max 24 V.

△ Note: camera housing power supply must always be carried with input power supply of 24VAC.

ACCESSORIES

- EXHS000 Sunshield 640 mm for EXHC000
- EXHS001 Sunshield 760 mm for housing with glass protection device EXHD001

RELATED PRODUCTS

Brackets:

- EXWBJ000 Housing wall bracket and ball joint for EXHC, EXHD
- EXBJ000 Balljoint for EXHC, EXHD

ENVIRONMENT

- Indoor/outdoor
- Operating temperature (limit range):
EXHC and EXHD: -20°C up + 50°C (-4°F up to 122°F)
- Operating temperature (limit range):
EXHC003R: -30°C a + 50°C (-22°F up to 122°F)

COMPLIANCE TO

According to the directive 94/9/CE Atex (certification released by TÜV Nord):

- Group: II (surface device)
- Category: 2 (elevated protection degree, the devices of this category can be installed in zone 1 and in zone 2)
- Atmosphere: G (only gas)
- EEx: explosion-proof
- d: flame proof
- IIC: gas group protection
- T6: temperature classification

EXHC000

- II 2 G Eex d IIC, T6
- 0032 according to 94/9/CE Atex
- IP65

EXHD001

- II 2 G Eex d IIB+ H2, T6
- 0032 according to 94/9/CE Atex
- IP65

SPARE PARTS LIST

- | | |
|----------|--|
| OCTEX3/4 | Ex-proof cable gland |
| OEXVET | Front flange complete with glass for EXHC000 |
| OEXDPV | Front flange complete with glass protection device for EXHD001 |
| OEXMYLAR | Mylar film replacement kit, L 18 m (59 ft) 350 steps |
| OSLIEX | Internal slide complete with heater for housing EXHC |
| OSLIEXD | Internal slide complete with heater for housing EXHD |

	Unit Weight (kg / lb):	Package Weight (kg / lb):	Package Dimensions (cm / in):	Master Carton (units):
	EXHC: 14,5 / 31.9 EXHD: 22,5 / 49.6 EXWBJ: 6,8 / 15 EXBJ: 3 / 6.6	EXHC: EXHD: EXWBJ: EXBJ:	EXHC: EXHD: EXWBJ: EXBJ:	EXHC: EXHD: EXWBJ: EXBJ: