

SALES NETWORK

· SAMSUNG TECHWIN CO., LTD.

145-3, Sangdaewon 1-dong, Jungwon-gu, Seongnam-si,
Gyeonggi-do 462-703, Korea
TEL : +82-31-740-8137-8141 FAX : +82-31-740-8145

· SAMSUNG OPTO-ELECTRONICS AMERICA, INC. ELECTRONIC IMAGING DIV.

40 Seaview Drive, Secaucus, NJ 07094, U.S.A
TEL : +1-201-902-0347 FAX : +1-201-902-0429

· SAMSUNG TECHWIN MOSCOW OFFICE

Korp 14, 37-A, PR-KT1, Leningradsky, Moscow 125167, Russia
TEL : +7-95-258-9296,9298 FAX : +7-95-258-9297

· SAMSUNG OPTO-ELECTRONICS UK, LTD.

Samsung House, 1000 Hillswood Drive, Hillswood Business
Park Chertsey, Surrey KT16 0PS
TEL : +44-1932-45-5308 FAX : +44-1932-45-5325

· TIANJIN SAMSUNG OPTO-ELECTRONICS CO., LTD.

7 Pingchang Rd, Nankai Dist. Tianjin 300190, P.R China
TEL : +86-22-2761-4724(33821) FAX : +86-22-2761-6514

www.samsungtechwin.com
www.samsungcctv.com

P/No. : Z6806-0669-01A
VAN 05. 09

1/2" Ultra Low Light Color Camera

INSTRUCTION MANUAL

SHC-740N/P

About this manual

Before installing and using the camera, please read this manual carefully. Be sure to keep it handy for later reference.

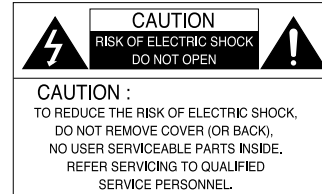

The lightning flash with an arrowhead symbol, within an equilateral triangle is intended to alert the user to the presence of uninsulated “dangerous voltage” within the product’s enclosure that may be of sufficient magnitude to constitute a risk of electric shock to persons.



The exclamation point within an equilateral triangle is intended to alert the user to the presence of important operating and maintenance (servicing) instructions in the literature accompanying the appliance.

INFORMATION - This equipment has been tested and found to comply with limits for a Class A digital device, pursuant to part 15 of the FCC Rules. These limits are designed to provide reasonable protection against harmful interference when the equipment is operated in a commercial environment. This equipment generates, uses, and can radiate radio frequency energy and, if not installed and used in accordance with the instruction manual, may cause harmful interference to radio communications. Operation of this equipment in a residential area is likely to cause harmful interference in which case the user will be required to correct the interference at his own expense.

WARNING - Changes or modifications not expressly approved by the manufacturer could void the user’s authority to operate the equipment.

CAUTION : To prevent electric shock and risk of fire hazards:

- ◆ Do NOT use power sources other than that specified.
- ◆ Do NOT expose this appliance to rain or moisture.

This installation should be made by a qualified service person and should conform to all local codes.

Fine Picture in Ultra Low illumination.

SV-III built-in DSP and 1/2 inch CCD allows bright and high quality images to be captured in ultra low light condition.

- Color : 0.08Lux (F1.2, 50IRE)
- Turbo : 0.04Lux (F1.2, 50IRE)
- BW : 0.01Lux (F1.2, 50IRE)

Wide Dynamic Range(WDR)

SV-III DSP has WDR function using flexible gamma.

It shows natural compensated image in any environment.

SV-III DSP CHIP

SHC-740 has powerful DSP that can remove image noise efficiently and it shows clear and obvious image under low illuminance.

High Resolution

The horizontal resolution of 530TV lines at Color mode and 570TV lines at BW mode can be achieved by using a half inch CCD having 410,000 pixels SONY CCD, which provides clean, noiseless and reliable pictures.

Day & Night

The camera provides automatic mode change over by sensing day or night conditions. It can change color mode in the day condition for optimal color and BW mode in night condition for clear identification.

Motion Detection

The camera transmits an alert signal to the MD Output Terminal when it detects motion of an object. If you connect an optional alarm to the camera, you can get the effective surveillance.

VIDEO/DC Lens Selectable

The camera accepts 2 types of auto iris lenses (DC type/VIDEO type) and is set with the VIDEO/DC selection switch.

Miscellaneous Function

The camera provides various miscellaneous functions which are privacy zone masking, digital zoom, Burst ON/OFF, SYNC selection (INT/LL), COLOR / TONE / SHARPNESS adjustment.

Controlled by OSD menu and RS-232C

You can control the camera using OSD menu and RS-232C jack at a remote place.

The camera needs periodic inspection.

Contact an authorized technician for inspection.

Stop using your camera when you find a malfunction.

If you use your camera around smoke or unusual heat for a long time, a fire may be caused.

Do not Install the camera on a surface that can not support it.

Unless the surface is suitable, it could cause falling or other hazards.

Do not hold plug with wet hands.

It could cause an electric shock.

Do not disassemble the camera.

It may result in fire, electric shock or other hazards.

Do not use the camera close to a gas or oil leak.

It may result in fire or other hazards.

Correct Disposal of This Product (Waste Electrical & Electronic Equipment)



(Applicable in the European Union and other European countries with separate collection systems) This marking shown on the product or its literature, indicates that it should not be disposed with other household wastes at the end of its working life. To prevent possible harm to the environment or human health from uncontrolled waste disposal, please separate this from other types of wastes and recycle it responsibly to promote the sustainable reuse of material resources. Household users should contact either the retailer where they purchased this product, or their local government office, for details of where and how they can take this item for environmentally safe recycling. Business users should contact their supplier and check the terms and conditions of the purchase contract. This product should not be mixed with other commercial wastes for disposal.

Contents

Precautions	8
Composition	10
Name and Function of Each Part	11
■ Front	11
■ Side	12
■ Bottom	13
■ Back	14
Connection	15
■ Lens	15
• Installing Auto Iris Lens	
• Installing C/CS-Mount Lens	
■ Connecting to Monitor	19
■ Connecting to Power	20

Operating Your Camera	21
■ Configuration of The Menu	21
■ Setting Up The Menu	22
• CAMERA ID	23
• BACKLIGHT	26
• WHITE BALANCE	27
• MOTION DETECTION	28
• LENS SELECTION	30
• SHUTTER SPEED CONTROL	32
• AGC	34
• SENS-UP	35
• SSNR	36
• SPECIAL	37
Using Reomte Jack / MD Output / D&N Input	40
Troubleshooting	42
Specifications	44

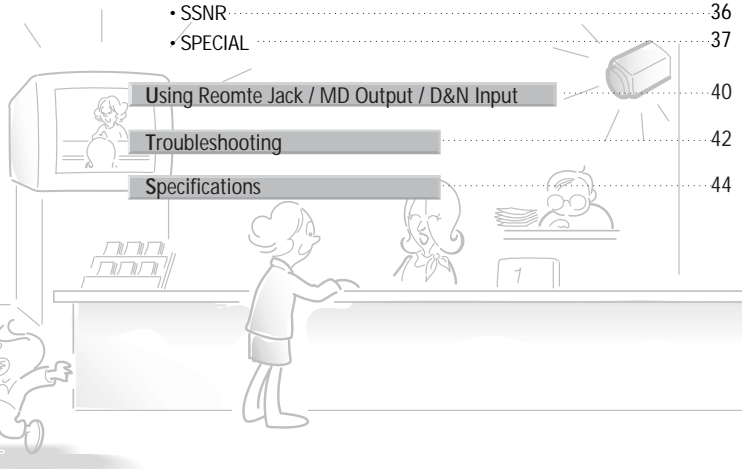

Precautions

Do not install the camera in extreme temperature conditions.



Only use the camera under conditions where temperatures are between -10°C and $+50^{\circ}\text{C}$. Be especially careful to provide ventilation when operating under high temperatures.

Do not install or use the camera in an environment where the humidity is high.



It can cause the image quality to be poor.

Do not drop the camera or subject them to physical shocks.



It can cause malfunctions to occur.

Never keep the camera face to strong light directly.

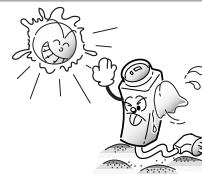

It can damage the CCD.

Do not install the camera under unstable lighting conditions.

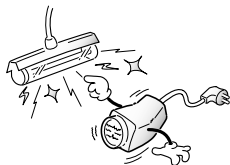

Severe lighting change or flicker can cause the camera to work improperly.

Do not touch the front lens of the camera.



It is one of the most important parts of the camera. Be careful not to be stained by fingerprint.

Do not expose the camera to rain or spill beverage on it.



If it gets wet, wipe it dry immediately. Liquids can contain minerals that corrode the electronic components.

Do not expose the camera to radioactivity.



If it is exposed to radioactivity, For heated CCD, it will be out of order.



Notes

- If the camera is exposed to spotlight or object reflecting strong light, smear or blooming may occur.
- Please check that the power satisfies the normal specification before connecting the camera.

Composition

1. SHC-740

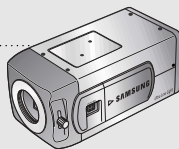

2. Auto Iris Lens Plug

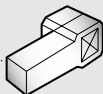

3. Remote Plug

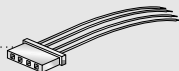

4. C-Mount Adapter



5. Instruction Manual



Name and Function of Each Section

Front

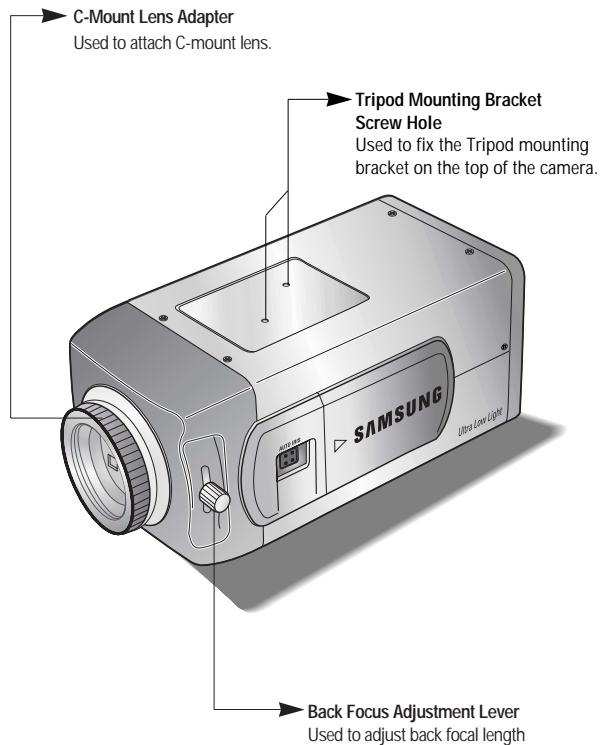

Name and Function of Each Section

Side

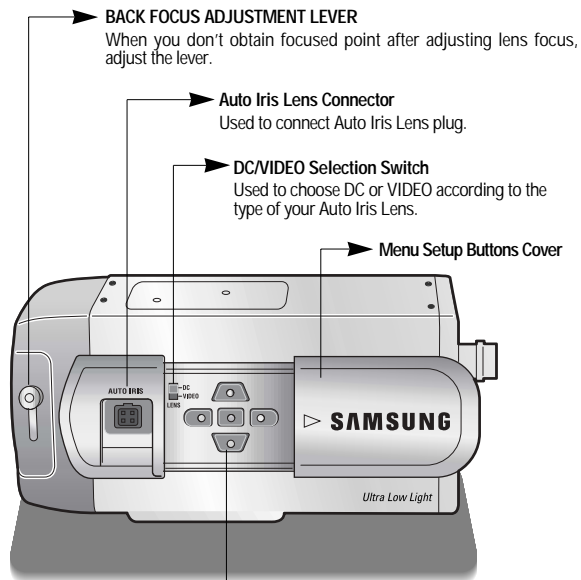

Menu Setup Buttons

- **SET Button:** Used to access menu mode. Also used to confirm the setting.
- **UP/DOWN Button:** Used to choose the desired menu item. It also moves the cursor up or down in the menu screen.
- **LEFT/RIGHT Button:** Used to change the parameter of the selected menu item. It also moves the cursor the left or right in the menu screen.

Bottom

Tripod Mounting Hole

Used to install the camera on an optional tripod. The tripod must be equipped with the screw specified as shown below.

1/4"-20 UNC (20 THREAD)
L: 4.5mm±0.2mm (ISO standard),
or 0.197" (ASA standard)

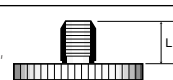

Tripod Mounting Bracket

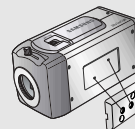
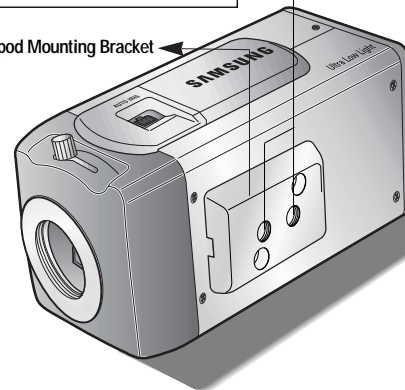

You can remove and install this bracket on the top of the camera. You must use the supplied screw or the equivalent (within 4mm). If not, the bracket may not be fixed properly.

Back

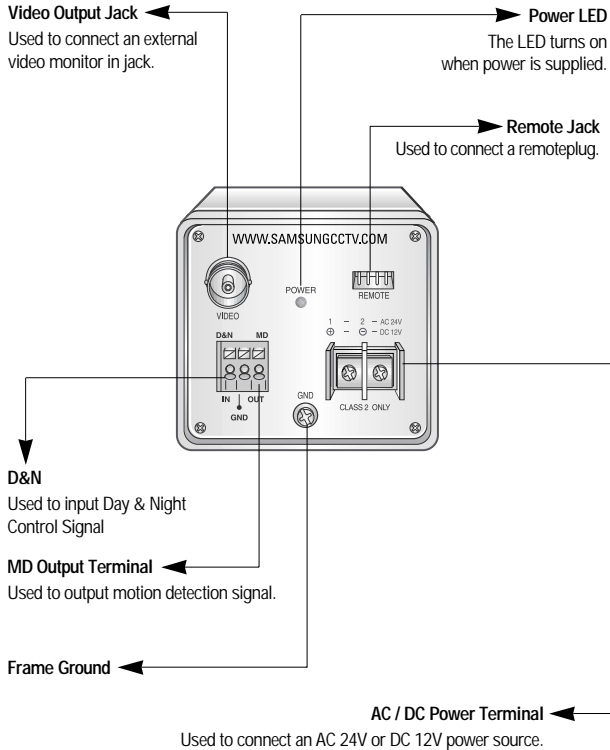

■ LENS

The lens is not supplied with this camera. Purchase a lens suitable for your environment. This camera accepts the auto iris lens and both C- and CS-mount lens.



Notes

- If the lens is marked with fingerprints or other marks, the image quality might be poor.
- It is recommended to use a high quality lens to improve the image quality under low illumination.
- For using main functions it is recommended to use Auto Iris Lens with DC type.

Installing Auto Iris Lens

1. Peel approximately 8mm from the end of the lens cable outer cover.

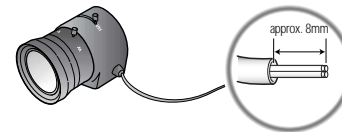

2. Peel approximately 2mm from the end of the cable inner cover.

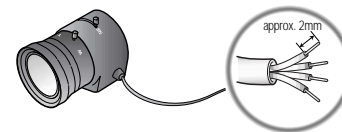

Connection

3. Remove the cover from the iris lens plug supplied, and solder the lens cable to the plug as shown below.

• **Video type :**

- No. 1 Pin --- Red (Power source)
- No. 2 Pin --- N.C
- No. 3 Pin --- White (Video signal)
- No. 4 Pin --- Black (GND)

• **DC type :**

- No. 1 Pin --- Damping -
- No. 2 Pin --- Damping +
- No. 3 Pin --- Drive +
- No. 4 Pin --- Drive -

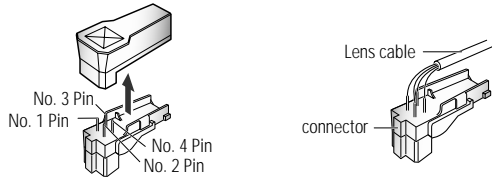

4. Remove the protective cap, and attach the lens to the camera by turning clockwise.

5. Connect the lens plug to the auto iris connector on the right side of the camera.

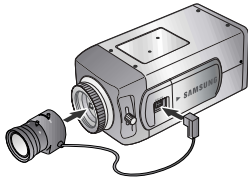

6. Set the DC/VIDEO selection switch to DC or VIDEO according to the type of the lens.



Installing C/CS-Mount lens

Before mounting a lens, please check whether it is a C-mount or CS-mount lens. The back focus is set for the CS-mount lens at the factory.

• **Mounting a CS-Mount lens**

After removing the protecting cap, attach the lens into the camera by turning clockwise.

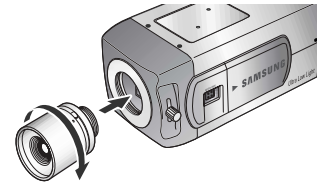

Notes

- Use the lens under the specification as shown. Otherwise the lens can damage the camera or abnormal fixing may result.

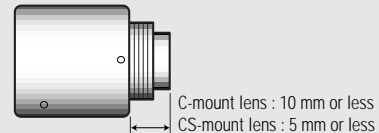

- A heavy lens may disturb the balance with the camera and possibly result in damage. Don't use a lens heavier than 450g.
- It is recommended to set the lens ALC mode to Av mode (Average). Pk mode can be occurred hunting.

Connection

• Mounting a C-Mount lens

1. Attach the C-Mount lens adapter by turning clockwise.

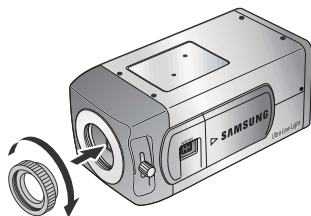

2. Attach the lens to the camera by turning clockwise.

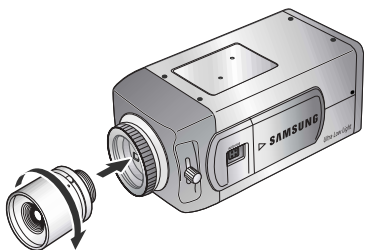

■ Connecting to Monitor

Connect the VIDEO Out jack to the monitor VIDEO In jack.

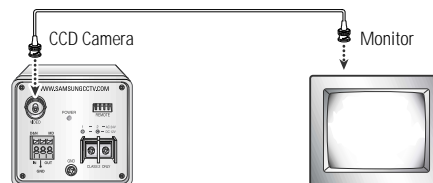

- As the connecting method varies with the instruments, refer to the manual supplied with the instrument.
- Only connect the cable when the power is turned off.
- Set the 75Ω/Hi-Z selection switch as shown below if you have an intermediate device.

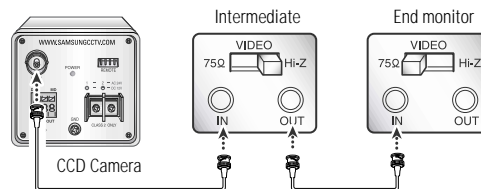

■ Connecting to Power

Each model has different power specification. Please check the name of the model and power specification before connecting to power source.

For AC / DC Power Type

- The wire is polarized. Be sure to connect the wire that white line is on covering to '-' terminal and connect the other one to '+' terminal.
- Use AC 24V/500mA or DC 12V/500mA power source for SHC-740N/P

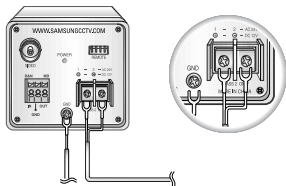

Resistance of copper wire [at 20C° (68°F)]

Copper wire size (AWG)	#24(0.22mm ²)	#22(0.33mm ²)	#20(0.52mm ²)	#18(0.83mm ²)
Resistance (Ω / m)	0.078	0.050	0.030	0.018
Voltage Drop (V/m)	0.028	0.018	0.011	0.006

- As the voltage drop according to the length of the cable in the above table, a camera may malfunction if there is an excessively long cable run.

* Voltage for camera operation: 12V DC ±10%

* Voltage drops in the above table are variable according to types of cable manufacturer.

■ Configuration of The Menu

SETUP MENU	CAMERA ID	• OFF	• ON		
	BACKLIGHT	• WDR	• OFF		
	WHITE BAL.	• ATW	• AWC	• MANUAL	
	MOTION DET.	• OFF	• ON		
	LENS	• DC / VIDEO	• MANUAL		
	SHUTTER	• ESC	• A.FLK	• MANUAL	
	AGC	• OFF	• LOW	• HIGH	• TURBO
	SENS-UP	• OFF	• AUTO		
	SSNR	• OFF	• LOW	• MIDDLE	• HIGH
	SPECIAL	• D-ZOOM	• PRIVACY	• DAY/NIGHT	• SYNC
		• IMAGE ADJ	• PRESET	• RETURN	• EXIT
					EXIT

Operating Your Camera

■ Setting Up The Menu

Use the five Setup Menu buttons on side of the camera.

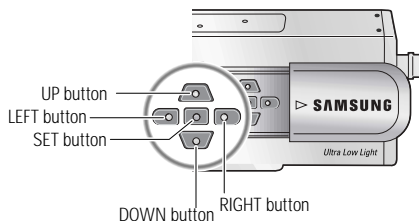

1. Press the SET button to access the setup mode.
 - Setup menu is displayed on the monitor screen.

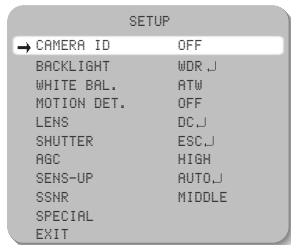

2. Select the desired feature using the UP or DOWN button.
 - Each time you press the UP or DOWN button, the arrow indicator moves up or down.
 - Move the arrow indicator to the desired feature item.

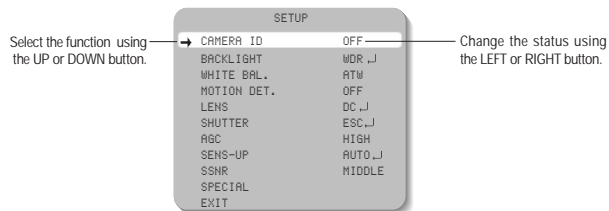

3. Change the status of the selected feature using the LEFT or RIGHT button.
4. When completed, move the arrow indicator to 'EXIT' and press the SET button.

Notes

- For the mode with ↵ you can access submenu.
- You can access submenu using SET button.

Camera ID

If you enter a camera ID, the name will be displayed in the screen monitor.

1. Press the SET button to display the setup menu and move the arrow indicator to 'Camera ID' using the UP or DOWN button.
2. Set 'Camera ID' to 'ON' using the LEFT or RIGHT button.

Notes

- If the camera ID feature is set to 'OFF', the name will not displayed in the monitor.

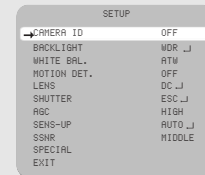

Operating Your Camera

3. Press SET button.

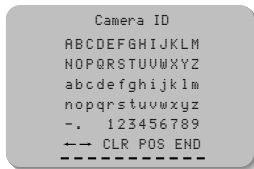

4. You can enter up to 15 characters.

- 1 Move the cursor to character-enter location by using the LEFT or RIGHT button.
- 2 Select the desired character by using LEFT, RIGHT, UP or DOWN button.

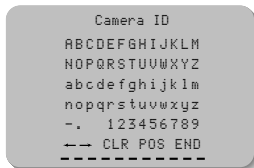

- 3 Press the SET button to confirm the blinking character. The first character is saved and the cursor in the bottom of the screen moves to the next position.
- 4 Repeats steps 1 and 2 until you create the full name you want.



Notes

- **If you make a mistake while entering name**

Move the cursor to 'CLR' and press 'SET' button, all characters will be removed. If you want to correct each character, locate the cursor on the position that you desire to erase using the arrow sign. And correct the character.

5. Select the position at which the camera ID will be located on the screen.

- 1 Move the cursor to 'Pos' and press SET button.

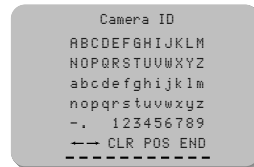

- 2 The camera ID is displayed on the top-left of the monitor screen. (Default position)



- 3 Select the position by using the 4-directional buttons, then press the SET button to confirm the position.



6. When completed, move the cursor to 'End' and press SET button.

Operating Your Camera

Backlight

The built-in SVIII DSP chip provides intelligent light level control to overcome the severe Backlight conditions.

1. Press the SET button to display the setup menu and move the arrow indicator to 'Backlight' using the UP or DOWN button.

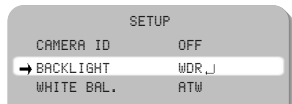

2. SET 'Backlight' to the desired mode using the LEFT or RIGHT button.

- **WDR:** In case that bright and dark parts exist on the screen at the same time, your camera allows you to see both parts clearly
- **OFF:** Deactivation



WDR



OFF

3. Press the 'SET' button.

- When 'WDR' is chosen, you can adjust the LIMIT.

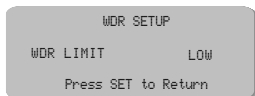

You can select the level(LOW,MIDDLE,HIGH).
WDR sensitivity is increased or decreased.

4. When completed, press the SET button.



Notes

- If you select manual in 'shutter' menu, you can't use WDR mode.
- If you select WDR mode, the following phenomenon may appear by lighting condition. In these cases do not select WDR mode.
 - Noise of bright part on the screen
- According to the area of bright part on the screen there may be the difference of WDR performance so be sure to adjust the degrees of the visual angle when installing your camera.
- As you operate WDR LIMIT stronger, noise can be seen more on image.
- For the optimal WDR performance, in case of observing the object that is in the place of the changing illumination, recommend to use Auto Iris Lens(Video or DC type, not manual)

White Balance Control

Your camera provides 3 'White Bal.' control modes. You can select the most suitable one. You can adjust the white balance.

1. Press the SET button to display the setup menu and move the arrow indicator to 'White Balance' using the UP or DOWN button.
2. Set 'White Bal.' to the desired mode using LEFT or RIGHT button.

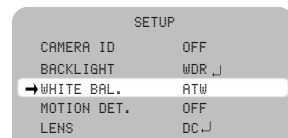

The four white balance control modes are as follows :

- **ATW(Auto Tracking White Balance):** When color temperature is 1800 ~ 10500K, select this mode.

Operating Your Camera

❶ **AWC(Auto White balance Control):** The white balance is automatically adjusted in a specific environment. In order to obtain the best result, press the SET button while the camera focuses on white paper. If the environment including the light source is changed, you have to adjust the white balance again.

❷ **Manual:** To fine adjust, select the Manual mode. You can increase or decrease the red or blue factor while monitoring the difference on the screen. Set to 'Manual' mode and press the SET button. Increase or decrease the value for red(R-Gain) and blue(B-Gain), watching the color of the picture, and press the SET button when you obtain the best color.



Notes

- Proper White Balance may not be obtained under the following conditions.
 - ❶ When the scene contains mostly high color temperature object, such as a blue sky or sunset.
 - ❷ When the scene is dim.
 - ❸ If your camera faces fluorescent lamp directly or is installed in the place of the changing illumination.

Motion Detection

Your camera transmits an alert signal when it detects motion of an object on the screen. If you connect the camera to an external alarm, you can pay attention to the screen when the alarm sounds. This feature is useful when you have to monitor several screens simultaneously.

1. Press the SET button to display the setup menu and move the arrow indicator to 'Motion Det.' using the UP or DOWN button.

2. Set 'Motion Det.' to the ON mode using LEFT or RIGHT button.

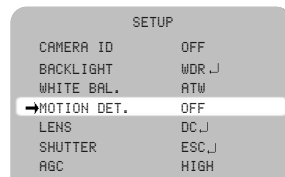

❶ Press SET button.

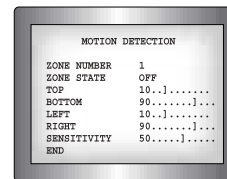

- ❷ Select the two kinds of ZONE NUMBER(1 or 2), ZONE 1 covers larger area than 2.
- ❸ Turn on ZONE STATE, then MD starts to be activated.
- ❹ Move the cursor to the desired menu and adjust it. You can increase or decrease the detection area adjusting TOP, BOTTOM, LEFT, RIGHT values.
- ❺ You can increase or decrease the detection sensitivity adjusting SENSITIVITY value.

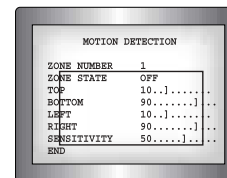

Operating Your Camera

- When completed, press END button.

Notes

Tips on Using the Motion Detection Feature

- After selecting zone and sensitivity, perform a test operation to make sure it works properly.
- If the lighting flickers, the motion detection feature might not work properly.
- The object should occupy 10% or more of its zone. The bigger the object, the higher sensitivity.
- If the brightness of an object changes rapidly by sudden lighting change, the camera may detect it as a motion.
- When this feature is activated, another algorithm may take more time to be operated.
- This system does not guarantee prevention of fires or thefts. The manufacturer is not responsible for any accident or damage.
- You can use the MD output terminal jack on the rear of the camera to connect an external alarm device. For details, see page 40.

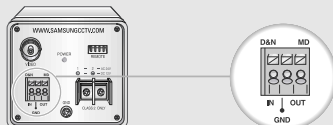

Lens Selection

You can set the type of the lens, and control the brightness of the screen.

1. Press the SET button to display the setup menu and move the arrow indicator to 'Lens' using the UP or DOWN button.
2. Set 'Lens' to the desired mode using LEFT or RIGHT button.
 - You can select from DC / Video, Manual

- **DC / Video:** When using auto iris lens

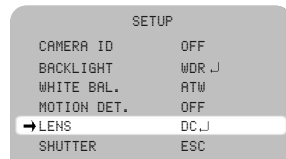

Notes

When using Auto Iris Lens with Video type

- ① Adjust ALC volume on the lens properly. Normally ALC volume should be turned all the way to Av(Average).
- ② According to the type of the lens used, the lens may not perform properly. In such a case, adjust the volume level on the lens.
- ③ Set AGC / SENS-UP OFF and adjust Lens VR to get proper brightness.
- ④ Increase or decrease BRIGHTNESS LEVEL after adjusting Lens VR. If image brightness doesn't change according to BRIGHTNESS LEVEL, adjust Lens VR again.



- **Manual:** When using manual lens

Operating Your Camera

Notes

- When the auto iris lens is mounted, you have to set the DC/Video selection switch on the side of the camera properly according to the type of the lens. The setup window displays DC or Video according to status of this selection switch. (refer to page 12 picture)
- If you select 'DC / Video' mode, you can adjust the desired Brightness.
- There may be some lenses that malfunction according to BRIGHTNESS LEVEL.

3. Press 'SET' button to return to previous menu.

Shutter Speed Control

You can control brightness of the screen by the shutter speed.

1. Press the SET button to display the setup menu and move the arrow indicator to 'Shutter' using the UP or DOWN button.
2. Set 'Shutter' to the desired mode using the LEFT or RIGHT button.

ⓐ **A.FLK(1/100 for NTSC Model, 1/120 for PAL Model)**

: Flickerless mode

ⓑ **ESC:** When setting the optimal shutter speed automatically

ⓒ **Manual:** When setting shutter speed manually

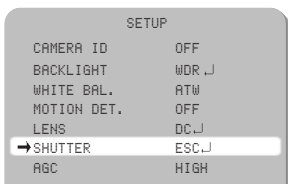

3. If you choose 'Manual', select the optimal shutter speed.

- You can select speed from '1/60' to '1/100,000'sec (NTSC Models), '1/50' to '1/100,000'sec (PAL Models).
* It is possible to adjust Sens-Up(x2 ~ x128) mode manually.
- When the shutter speed is increased or decreased using the LEFT or RIGHT button, you can find the difference by monitoring the brightness of the screen.



4. When completed, press the SET button.

Notes

- For effective A.FLK mode set WDR mode in Backlight menu to OFF. A.FLK mode is not effective with WDR mode.
- If the camera directly faces strong fluorescent light with 'ESC' mode, the image may become unstable.
- If you choose 'ESC', you can adjust the brightness of monitor screen using the LEFT or RIGHT button.
- If you choose Manual mode, you can't use WDR mode in 'Backlight' menu.
- If you select manual or A.FLK mode, Sens-up is not operated.

Operating Your Camera

AGC (Auto Gain Control)

To get brighter picture.

1. Press the SET button to display the setup menu and move the arrow indicator to 'GAIN' using the UP or DOWN button.
2. Set 'gain' to desired mode using the LEFT or RIGHT mode.
 - ☉ **TURBO** : In ultra low luminance, D-gain operates after gain reaches max 34dB.
 - ☉ **HIGH** : Gain is increased or decreased from 0 to 34dB automatically as following the illumination.
 - ☉ **LOW** : Gain is increased or decreased From 0 to 24dB automatically as following the illumination.
 - ☉ **OFF** : Deactivation

SETUP	
CAMERA ID	OFF
BACKLIGHT	WDR ↓
WHITE BAL.	ATW
MOTION DET.	OFF
LENS	DC ↓
SHUTTER	ESC ↓
→ AGC	HIGH
SENS-UP	AUTO ↓
SSNR	MIDDLE
SPECIAL	
EXIT	

SENS-UP

You can always get the clear image with this function under night or low-lighting level.

1. Press the SET button to display the setup menu and move the arrow indicator to 'Sens-up' using the UP or DOWN button.
2. Set 'Sens-up' to the desired mode using the LEFT or RIGHT button.
 - ☉ **Auto**: When your camera is under night or low-lighting level, select this mode.
 - ☉ **OFF**: Deactivation

SETUP	
CAMERA ID	OFF
BACKLIGHT	WDR ↓
WHITE BAL.	ATW
MOTION DET.	OFF
LENS	DC ↓
SHUTTER	ESC ↓
AGC	HIGH
→ SENS-UP	AUTO ↓
SSNR	MIDDLE
SPECIAL	
EXIT	



Notes

- If you press the set button on 'Auto' mode. You can adjust brightness by increasing or decreasing the shutter speed. (EX. x2, ..., x32, x64, ..., x128)
- If you increase the number of shutter speed, moving object gets a more afterimage.
- Under Sens-up activated noise, sports or a whitish phenomenon may appear in the picture as the sensitivity of the camera is increased. This is normal phenomenon.

Operating Your Camera

SSNR (Samsung Super Noise Reduction)

To reduce the noise on the screen.

1. Press the SET button to display the setup menu and move the arrow indicator to 'SSNR' using the UP or DOWN button.
2. Set 'SSNR' to desired mode using the LEFT or RIGHT mode.

- ☉ **LOW:** low reduction of the noise
- ☉ **MIDDLE:** middle reduction of the noise
- ☉ **HIGH:** high reduction of the noise
- ☉ **OFF:** Deactivation

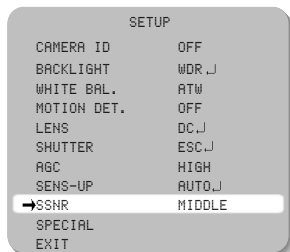

Notes

- If you change the 'AGC' menu from LOW to HIGH, sensitivity is increased as well as noise on the screen.
- If AGC is OFF, you can't select LOW/MIDDLE/HIGH on SSNR menu.

SPECIAL



1. Press the SET button to display the setup menu and move the arrow indicator to 'SPECIAL' using the UP or DOWN button.
2. Press the SET button.

- ☉ **D-ZOOM:** You can select an electronic zoom mode among x2, x4, x8 mode.

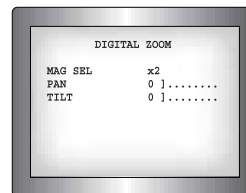

- After selecting zoom mode you want, adjust PAN and TILT value by pushing the left or right key to locate the position that you want to see.

Operating Your Camera

PRIVACY: To mask area which you want to mask

- OFF: Deactivation
- ON: Privacy mode activated
- Press the SET button.

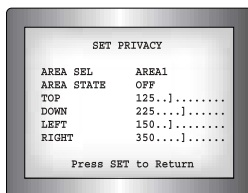

- 4 AREAS are selectable. Select the area you want (AREA1, AREA2, AREA3, AREA4)
- Set AREA STATE 'ON' using LEFT or RIGHT button.
- Make the size of PRIVACY AREA by changing TOP, DOWN, LEFT, RIGHT values.

DAY/NIGHT: choose color or B/W mode.

- COLOR : color mode
- B/W : B/W mode
- EXT : It enables user to control DAY/NIGHT mode by inputting external signal.
- AUTO : Under general condition, D/N filter is fixed at DAY mode, but under low luminance condition, it change into NIGHT mode automatically. The case of the opposition is also same.



Notes

- When you use Auto Iris Lens with Video type, do not set the level on the lens to too low, Color/BW may not change over automatically.
- When Gain in SET UP menu is OFF, Color / BW do not change over automatically.
- If AGC is OFF, you can't select AUTO mode on DAY/NIGHT menu.
- For the stable operation, whenever the mode is changed over between color and BW mode, five setup menu buttons on the camera do not operate for about 3 seconds.
- It is possible to turn on or off the burst signal on B/W mode.
- The object may be more out of focus when using a source of near-infrared light than using the visible light.

SYNC: Two SYNCHRONIZATION modes are available INTERNAL and EXTERNAL LINE-LOCK. In LINE-LOCK mode, it synchronizes the video signal between cameras without a synchronous generator. The line-lock synchronization is only used in the areas of 60Hz (NTSC Models) / 50Hz (PAL Models).

- INT : Internal synchronization
- LL : External line-lock synchronization
- If you choose 'LL', you can adjust the desired phase. Press the SET button.
- You can adjust the desired phase from 0 to 359.

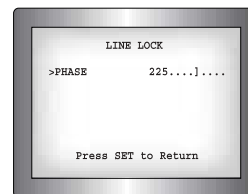

Notes

- When the power frequency is 50Hz, you can not use line-lock mode (NTSC Models).
- When the power frequency is 60Hz, you can not use the line-lock mode (PAL Models).
- 'Sync.' mode is fixed to 'INT' in DC 12V input power.

Operating Your Camera

- ❶ **IMAGE ADJ:** This includes the factors related to the image quality or special function.
 - TONE : As you increase the value using left or right button the whole level would be brighter.
 - SHARPNESS : As the value goes high, edge of image become strong and obvious. But if increasing the value too much, some noise may appears on image and image may looks unnatural.
 - COLOR : As you increase or decrease the value, image chroma level increases or decreases but the burst level doesn't.
- ❷ **PRESET:** To reset your camera to factory default condition
- ❸ **RETURN:** To move Top-menu
- ❹ **EXIT:** To finish setting menu

Using Remote Jack / MD Output / D&N Input

If you connect a remote plug to the REMOTE jack on the rear of the camera as shown below, you can access the menu setup mode from a remote place.

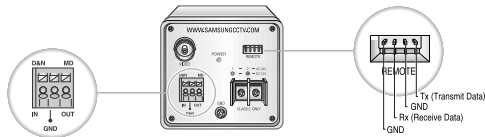

1. RS-232C Communication Setting.

- Mode : Serial
- Data Bit : 8
- Bit/sec : 9600bps
- Stop Bit : 2
- Port : Com1
- Parity : None
- Flow Control : XON/XOFF

2. Setup menu Command.

Setup menu	Command	Byte
Set	153	1
Up	65	1
Down	66	1
Right	67	1
Left	68	1

3. MD(Motion Detection) output Signal Level(less than 10mA)

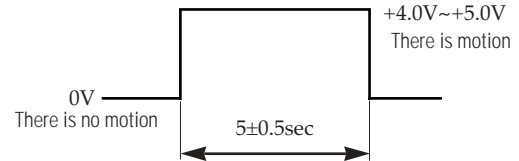

4. D&N input Control Signal

If you want to use EXT mode, consist proper system that satisfy below condition

- For DAY mode, D&N terminal should be open from GND terminal.
- For B/W mode, D&N terminal should be short to GND terminal.



Notes

- You must turn the camera power off when you connect or remove the remote plug.

Troubleshooting

If you have trouble operating your camera, refer to the following table. If the guidelines do not enable you to solve the problem, contact an authorized technician.

Problem	Solution
Nothing appears on the screen.	<ul style="list-style-type: none"> • Check that the power cord and line connection between the camera and monitor are fixed properly. • Check that you have properly connected VIDEO cable to the camera VIDEO output jack. • Check that the DC/VIDEO selection switch on the side of the camera is set to a proper position according to the type of your auto iris lens. • Are you using Auto Iris Lens with VIDEO type? Adjust VR Level properly (refer to page 31)
The image on the screen is dim.	<ul style="list-style-type: none"> • Is lens stained with dirt? Clean your lens with soft, clean cloth. • Set the monitor to proper condition. • If the camera is exposed to too strong light, change the camera position. • Adjust the lens' focus properly.
The image on the screen is dark.	<ul style="list-style-type: none"> • Adjust the contrast feature of the monitor. • If you have an intermediate device, set the 75Ω / Hi-z properly. (refer to page 19) • Are you using the Auto Iris Lens? Adjust the level on the lens properly.
The camera is not working properly, and the surface of the camera is hot.	<ul style="list-style-type: none"> • Check that you have properly connected the camera to an appropriate power source. (refer to page 20)

Problem	Solution
Motion Detection function is not active.	<ul style="list-style-type: none"> • Have you set 'Motion Det.' menu to OFF? • Have you set 'SENSITIVITY' to too low? • Have you set 'MD Area' properly?
The color of the picture is not matched.	<ul style="list-style-type: none"> • Check that you have properly set the 'White Bal.' menu.
The image on the screen flickers.	<ul style="list-style-type: none"> • Is the camera facing to direct sunlight or fluorescent lighting? Change the camera position. • Are you using Auto Iris Lens? Check that you have properly connected the lens plug to the Auto Iris connector on the side of the camera.
L/L mode isn't able to be selected.	<ul style="list-style-type: none"> • Have you connected your camera to DC power source? Connect it to AC power source.
L/L is not operating properly.	<ul style="list-style-type: none"> • Check the frequency of power supply. (60Hz for NTSC, 50Hz for PAL)

Specifications



		NTSC (SHC-740N)	PAL (SHC-740P)
POWER		AC24/DC12(±10%), 4.5W	
C C D	Total Pixels	811(H) x 508(V)	795(H) x 596(V)
	Effective Pixels	768(H) x 494(V)	752(H) x 582(V)
	Size	1/2 inch, Diagonal 8mm interline CCD	
S Y N C.	Scanning System	2:1 Interlace	
	Synchronization	Internal/Line Lock	
	Frequency	Horizontal:15.734KHz, Vertical :59.94Hz	Horizontal: 15.625KHz, Vertical : 50.00Hz
E L E C T R I C A L	Resolution	530TV Lines(Min.)/Color, 570TV Lines(Min.)/BW	530TV Lines(Min.)/Color, 570TV Lines(Min.)/BW
	Video Output	1.0Vp-p/75Ω/Video 0.714Vp-p, Sync 0.286(Vp-p)	1.0Vp-p/75Ω/Video 0.7Vp-p, Sync 0.3(Vp-p)
	S/N (Y signal)	50dB (AGC Off, Weight ON)	
	Min. Illumination	Color : 0.08Lux(F1.2,50IRE), Turbo : 0.04Lux(F1.2,50IRE) B/W : 0.01Lux(F1.2,50IRE)	
	WDR	42dB	
	Day & Night	COLOR / BW/AUTO (Filter Auto Change) / EXT (External Day/Night mode control capability via terminal on the back panel)	
	Gain Control	Low, High, Turbo, OFF Selectable	
	White Balance	ATW/AWC/Manual (1,800°K ~ 10,500°K)	
	Electronic shutter speed	AUTO/MANUAL (1/60 ~ 1/100,000sec)	AUTO/MANUAL (1/50 ~ 1/100,000sec)
	Sens-Up	ON / OFF (selectable limit-X128)	
	O.S.D	Built-in	
	Motion Detection	ON / OFF (Built-in Alarm output connector)	
	RS-232C	Built-in	
	SSNR	Low, Middle, High, OFF Selectable	
	D. ZOOM	Built-in (~X8, Pan Tilt)	
	Privacy Function	ON/OFF (4 Programmable Zone)	
IRIS Control	DC / Video		
Lens Mount	CS Mount (Easy Focus type)		
Dimension	70(W) X 56(H) X 130(D)mm		
Operating temperature	-10°C ~ +50°C [14°F ~ 122°F]		
Operating Humidity	Max 90% RH		
Weight	480g		

DECLARATION OF CONFORMITY

Application of Council Directive(s)	89 / 336 / EEC	
Manufacturer's Name	SAMSUNG TECHWIN CO., LTD	
Manufacturer's Address	SAMSUNG TECHWIN CO., LTD 42, SUNGJU-DONG CHANGWON-CITY, KYUNGNAM, KOREA, 641-120	
European Representative Name		
European Representative Address		
Equipment Type/Environment	CCTV Camera	
Model Name	SHC-740N/P	
Beginning Serial NO.	S5900001	
Year of Manufacture	2005. 9. 1	
Conformance to	EN 50081-1 : 1992 EMC-Directive 89/336 EEC and 92/31/EEC EN 50130-4 : 1996	

We, the undersigned, hereby declare that the equipment specified above conforms to the above Directive(s).

Manufacturer	SAMSUNG TECHWIN CO., LTD	Legal Representative in Europe
Signature	<i>Young Taek SON</i>	Signature
Full Name	YOUNG TAEK SON	Full Name
Position	QUALITY CONTROL MANAGER	Position
Place	CHANGWON, KOREA	Place
Date	2005. 9. 1	Date

MEMO

MEMO